

# Oscilloscope RTSA Function Operation Guide and Applications



---

## Trademark Information

**SIGLENT** is a registered trademark of SIGLENT TECHNOLOGY CO., LTD.

## Statement

- Our products are protected by approved and pending patents of the People's Republic of China
- Our company reserves the right to change specifications and prices
- The information provided in this manual supersedes all previously published materials
- The contents of this manual may not be copied, excerpted, or translated in any form or by any means without the consent of our company

## Product Certification

SIGLENT certifies that this product complies with China's national product standards and industry product standards, and further certifies that this product complies with the relevant standards of other members of international standards organizations.

## Contact Us

Service Hotline: 400-878-0807

E-mail: [support@siglent.com](mailto:support@siglent.com)

Website: <https://www.siglent.com>

## RTSA Function Introduction

**Requirement:** SDS7000A series oscilloscope with FW version higher than V1.1.9.1R1. RTSA option enabled.

**Access:** Utility-----Spectrum Analysis

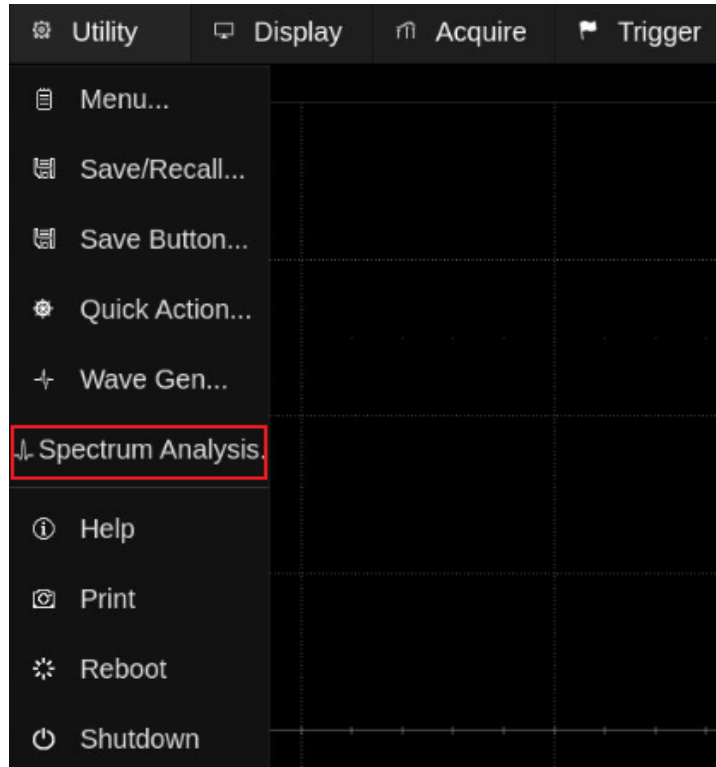

Figure 1 RTSA Function Access

In the RTSA interface, the layout is similar to other functions of the oscilloscope, making it easy for users to get started.

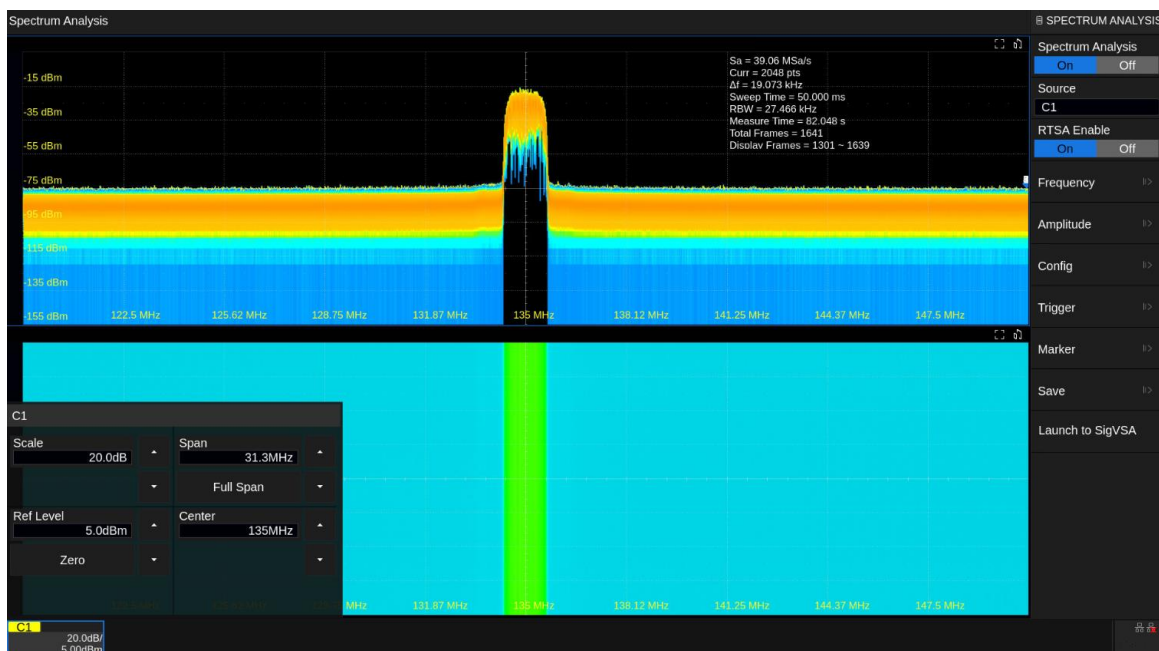

Figure2 RTSA Interface

The channel selection tab in the lower left corner is consistent with that in the oscilloscope, where you can adjust the scale and reference level, and you can also use the knobs on the keypad to adjust the parameters. The right column is the parameter setting options. In the source menu, you can switch between the channels (C1/C2/C3/C4). In the RTSA interface, the input impedance of each channel is fixed at 50Ω.

**Display of Parameter Information:** Next to the interface of the real-time spectrum analysis, there will be some parameter information, you can freely drag and drop to move this part of the information to the appropriate position, in the list shows the current use of the FFT sampling rate( $S_a$ ), the FFT max points(Curr), FFT sequence between the frequency interval between two neighboring points ( $\Delta f$ , i.e.,  $S_a/Curr$ ), the Sweep Time, the resolution bandwidth (RBW). After turning on the Spectrogram view by the RTSA, three additional parameters will appear: Measure Time, total frames, and Display frames. There is an upper limit for the number of display frames; the last 340 frames of the Spectrogram are displayed in a FIFO (First – in, first Out) manner.

**Frequency:** Select the start frequency and end frequency of the signal as well as the size of the span in Frequency. The selectable analysis bandwidths are 125MHz, 250MHz, 500MHz and 1GHz with each step representing a two-fold change.

**Amplitude:** In the Amplitude interface, the reference level, unit and scale are displayed. The reference level corresponds to the value indicated by the top scale line in the spectrum analysis interface, with a minimum resolution of 0.1dBm.

The default unit is dBm, and the scale is changed in steps of 1-2-5-10.

**Configuration:** The maximum number of FFT points (2k/4k/8k/16k/32k/64k/128k/256k/512k/1M/2M/4M/8M) can be set in the configuration interface, and the more FFT points you choose corresponds to a smaller resolution bandwidth, which results in a lower noise floor. At the same time, the selection of the window function type can also be carried out, using different types of windows whose  $\Delta f$  and RBW ratio relationship is also different.

Table 3 Window Types and Characteristics

Window	Characteristics	Main lobe width	Side lobe suppression	Maximum amplitude error
Rectangle	The best frequency resolution The worst amplitude resolution It is equivalent to the case of no window	$4\pi/N$	-13dB	3.9dB
Blackman	Poor frequency resolution Better amplitude resolution	$12\pi/N$	-58dB	1.1dB

Hanning	Better frequency resolution Poor amplitude resolution	$8\pi/N$	-32dB	1.4dB
Hamming	Better frequency resolution Poor amplitude resolution	$8\pi/N$	-43dB	1.8dB
Flattop	The worst frequency resolution The better amplitude resolution	$23\pi/N$	-93dB	< 0.1dB
Blackman-Harris	Poor frequency resolution Better amplitude resolution	$14\pi/N$	-67dB	0.9dB
Gaussian	Better frequency resolution Better amplitude resolution	$7.3\pi/N$	-55dB	1.0dB

Using a window minimizes discontinuities at the end of the signal interval, reducing spectral leakage and improving frequency resolution. In practice, select the appropriate window based on the signal type and measurement purpose.

**When RTSA Enable is off**, you can select the number and type of traces to display in the configuration interface, and enable the Math function to perform the arithmetic operations on the traces.

Currently, the maximum number of traces that can be set is 4, and each trace can be displayed in six ways (Clear Write, Max Hold, Min Hold, Average, View, Blank).

**Clear Write**: Erases any data previously stored in the selected trace, and display the data sampled in real-time of each point on the trace.

**Max Hold**: Retain the maximum level for each point of the selected trace. Update the data if a new maximum level is detected in successive sweeps and form a peak envelope.

**Min Hold**: Display the minimum value from multiple sweeps for each point of the trace and update the data if a new minimum is generated in successive sweeps and form a valley envelope.

**Average**: Set up to 100 averages to average the results of multiple calculations and reduce the effects of noise and other random signals.

**View**: Freezes the current spectrum display, pauses FFT processing, and maintains the contents of the current display buffer.

**Blank**: Disable the trace display and all measurements of this trace.

In the trace window, we can also choose to turn on the Math. When the Math is turned on, it will display five options: Output trace, Input Trace X, Input Trace Y, Offset and Function. When performing math operations, we need to select a trace channel as the output channel of the calculation results, and at the

---

same time, we can select traces for Input Trace X and Input Trace Y. Offset is a settable value with a setting range of -100dB~100dB. Three operations are available  $X-Y+Offset$ ,  $X+Y+Offset$  and  $X+Offset$ . The results are displayed in the Output trace.

The math function can only be used when the RTSA enable is turned off.

**When RTSA Enable is ON**, you can select from Five view combinations: Density, Spectrogram, 3D, 3D+Spectrogram and Density+Spectrogram.

**Density:** On the basis of the traditional spectrogram, the frequency of signal occurrence is visualized using a color scale, with cool to warm colors indicating the magnitude of the probability that the points in a frame of the waveform are mapped to the corresponding coordinate points. The density map can display multiple waveforms frames simultaneously and distinguish the probability of each Event's occurrence. This provides detailed frequency domain characteristics, helps identify rare signals, and allows observation of long term signal trends, offering more time-dimensioned acquisition information than a traditional spectrogram.

**Spectrogram:** Record the frequency domain characteristics of each event over time, the time represented by each trace that appears in the spectrogram is the sweep time, the signal amplitude of each frequency point is represented by different colors, i.e., the X-axis corresponds to the frequency of the sampling point, the Y-axis represents the time, and the color is the third dimension representing the amplitude of the signal, which is commonly used in wireless communication debugging, signal monitoring, and so on. It is commonly used in wireless communication debugging, signal monitoring and other applications.

**3D Map:** The 3D waterfall graph displays the observation window of waveform data in real time on the axes of time, frequency and amplitude, with the colors representing the amplitude values in the three coordinates, the peaks corresponding to the red vertex, and the valleys expressed in cool blue, which enables an intuitive three-dimensional view to present the changes of the signal's frequency-domain components over time. The sweep time for RTSA can be set from 30ms to 50s, with minimum step size of 0.001s. When entering RTSA, the number of FFT points is fixed at 2k and cannot be adjusted, but the window type can be changed normally.

The display traces are reduced to 3, and the detector type of the traces and the detector type of the spectrogram can be set, and there are four types of detectors available (Positive peak, Negative peak, Average, Sample).

**Positive Peak:** For each trace point, Peak detector displays the maximum value of data sampled within the corresponding time interval.

**Negative Peak:** For each trace point, Negative Peak detector displays the minimum value of data sampled within the corresponding time interval.

---

**Sample:** For each trace point, Sample detector displays the transient level corresponding to the central time point of the corresponding time interval.

**Average:** For each trace point, Average detector displays the average value of data sampled within the corresponding time interval and reduces the effect of noise.

**Trigger:** The trigger type can be selected in the trigger menu, and the default setting is Free Run.

When the RTSA Enable is off, it can be switched to IF Magnitude trigger, and there are two triggering modes: edge and state. In edge triggering mode, you can select the triggering edge as rising edge or falling edge, and trigger when the state value is set and the signal level is detected to exceed the set level. In state trigger mode, the trigger can be selected to be triggered in high level state or low level state, and will be triggered when the signal reaches the set level value.

When the RTSA enable is on, it is fixed as a free run, and a new frequency mask trigger function is added, which is similar to the oscilloscope mask test function after it is turned on, and a custom mask can be edited in the mask editor, and the edited template file can be directly loaded in the RTSA, or we can save the mask file and load the mask file directly next time when we need to use it, and pay attention to the fact that the frequency template trigger can only be applied in one trace.

**Marker:** We can add a cursor to the trace in the Marker tools, which provides two types of cursors: peak and marker. Under the peak cursor type, the oscilloscope will automatically mark up to 10 peak points according to the set search threshold and search excursion, and the peak points are numbered according to the frequency from smallest to largest, and you can choose to turn on the display of the peak table, frequency, and delta. When turned on, the amplitude, frequency, and delta in amplitude and frequency of each peak point compared to peak point 1 will be displayed. The criteria for selecting the peak is that the peak point should be greater than the search threshold, and if the search excursion is also set, the difference between the peak and the amplitude of the left and right minima needs to be greater than the set search excursion value in order to be judged as a peak.

The Marker tool is based on the Peak tool, with the addition of the ability to locate peaks and, similar to the cursor operation, the frequency of the markers can be set or the position of the cursor can be changed via the **Universal/A** button on the keypad. Up to 8 markers can be controlled, and The effect of other options is the same as in the Peak tool.

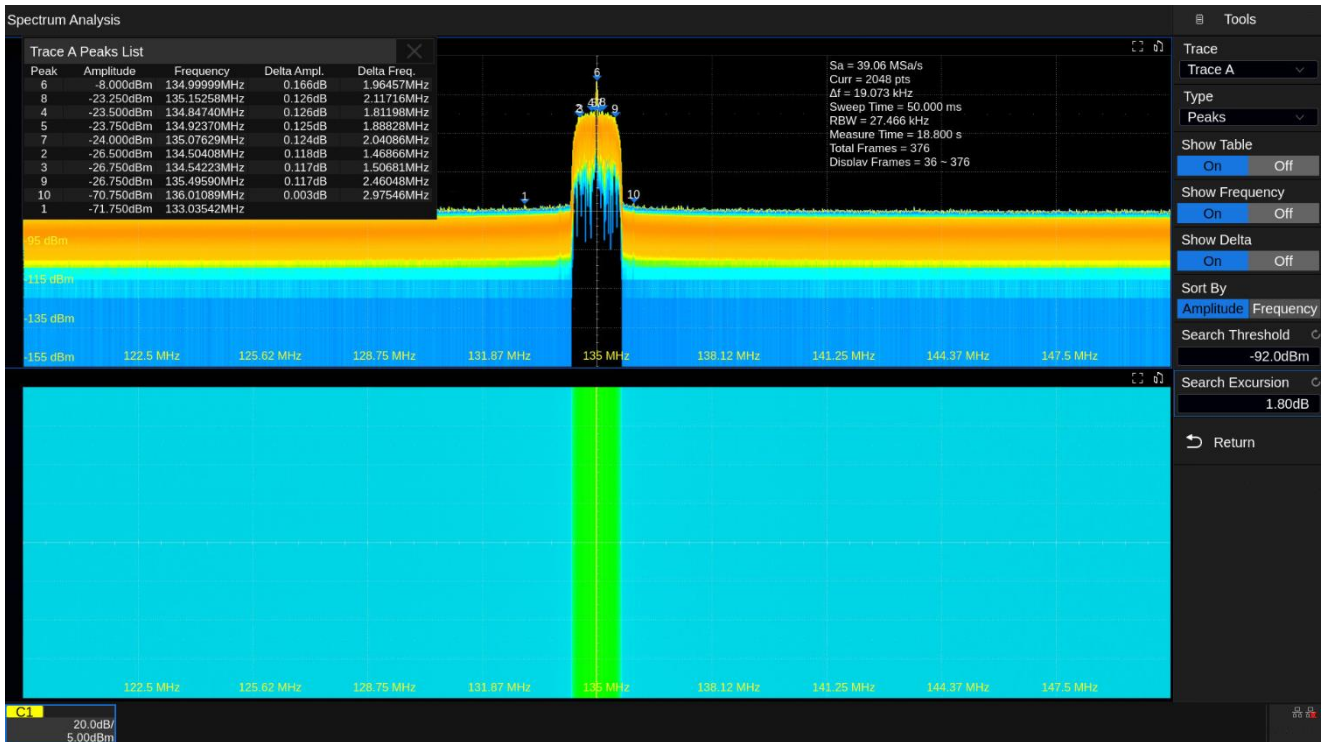

Figure 3 Peak Cursor Display

**Save:** The Save menu allows us to save the measurement results as IQ data in .txt file format. The saved data can be further analyzed in the SigVSA software built into the RTSA function.

SigVSA vector signal analysis software is also integrated into the RTSA, allowing users to analyze measured signals. The software supports analysis of general OFDM signals, cellular protocol standard signals such as 4G LTE and 5G NR, and various general modulation signals.

In the built-in SigVSA software, we can choose to connect with the oscilloscope to get the real-time captured waveforms directly from the oscilloscope for analysis, or we can also save the waveform data file for offline analysis.

## Digital Down Converter(DDC)

A Digital down converter(DDC) is a digital signal processing technology that convert RF signals into baseband signals to reduce the complexity of the subsequent processing. This is achieved mainly through the mixing, filtering and sampling of high-frequency signals as well as IQ signal acquisition.

In the receiver architecture, DDS is used to generate the quadrature principal oscillator signal and mix it with the input signal to shift the spectrum to the baseband, and then filter out the high-frequency components and mirror interference after mixing with a low-pass filter. This is followed by a down sampler section which reduces the data rate and sends it to a subsequent module for processing.

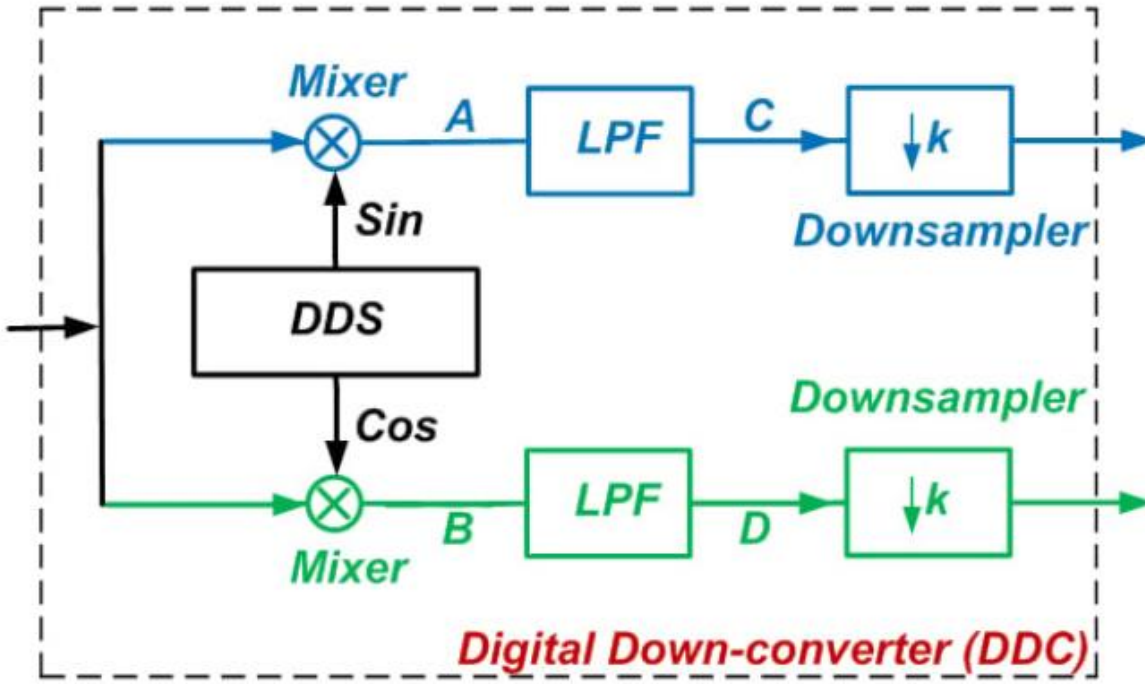

Figure 4 Receiver Digital Down-Conversion Module

Assume the digital signal acquired by the ADC is  $S(t)$ , where  $A(t)$  is the baseband signal amplitude,  $\varphi(t)$  is the baseband signal phase,  $\omega_c$  is the carrier signal frequency,  $\omega_{lo}$  is the frequency of the generated local oscillator signal.

$$S(t) = A(t) \cdot \cos(\omega_c t + \varphi(t))$$

The generated orthogonal local oscillator signals are multiplied to achieve spectral shift and obtain two signals in the same direction and orthogonal.

$$I(t) = S(t) \cdot \cos(\omega_{lo} t) = \frac{A(t)}{2} [\cos((\omega_c - \omega_{lo})t + \varphi(t)) + \cos((\omega_c + \omega_{lo})t + \varphi(t))]$$

$$Q(t) = S(t) \cdot (-\sin(\omega_{lo} t)) = \frac{A(t)}{2} [\sin((\omega_c - \omega_{lo})t + \varphi(t)) - \sin((\omega_c + \omega_{lo})t + \varphi(t))]$$

After processing, the difference frequency component is shifted to the low frequency, and the sum frequency component is located at the high frequency. After passing through the low-pass filter, the high-frequency component is filtered out to retain the baseband signal.

$$I_{filter}(t) = \frac{A(t)}{2} \cos \varphi(t)$$

$$Q_{filter}(t) = \frac{A(t)}{2} \sin \varphi(t)$$

After DDC, the amplitude and phase of the original signal are preserved. The two generated signals are resampling to reduce the data volume and improve processing efficiency.

The basic implementation of digital down conversion is fixed. Digital down conversion using an FPGA uses a Numerically Controlled Oscillator (NCO) to generate a quadrature principal oscillator signal which is mixed with the input signal.

After mixing, the high-speed data stream is initially decelerated by a cascaded integrator comb filter (CIC) that extracts an arbitrary factor from the data stream, followed by a half-band filter (HB) to further decelerate the data rate while maintaining the linear phase, followed by a FIR filter for the down conversion. The signal is then filtered by a FIR filter.

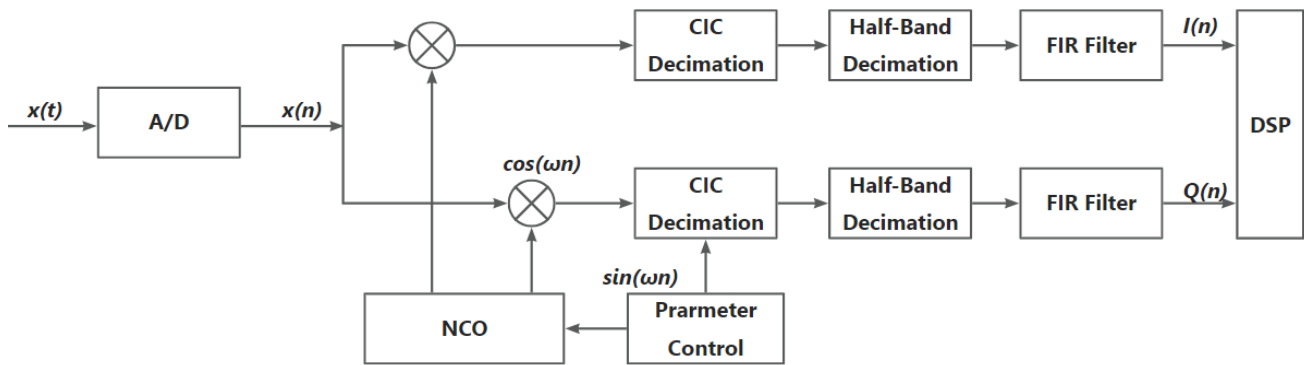

Figure 5 FPGA Digital Down-Conversion Architecture

Implementing the DDC function in oscilloscopes using FPGAs or ASICs reduces computational load while preserving essential signal parameters.

## RTSA Features

In the FFT time-domain conversion function that comes standard with most oscilloscopes, the oscilloscope directly performs FFT operations on the time-domain signals acquired by the ADC to process the data in the full frequency band, while the time domain and the frequency domain share the same data stream, and the time base needs to be adjusted to increase the sampling length when obtaining smaller resolution bandwidths, which will make the oscilloscope's processing speed decrease. Processing data in this way requires a sufficiently high sampling rate to achieve the analysis of high-frequency signals. Since, the Oscilloscopes storage space is limited, the duration for analyzing signals at high sampling rates correspondingly reduced.

In the acquisition and processing module of SDS7000A, a DDC structure is implemented, the signal is down-converted to baseband and only data within a specified Bandwidth at a set center frequency is proceed. The data can then be re-sampled at a lower sampling rate. Additionally, time domain and the frequency domain are captured independently, enabling longer signal acquisition and analysis periods.

at a higher speed under the condition of the unchanged storage space, and the processing speed can be maintained at a lower RBW, through which RTSA can be achieved. In this way, the spectrum parameters can be set directly during parameter adjustment without having to change the spectrum parameters in disguise by adjusting the time-domain parameters. The signal processing is put into a dedicated FPGA, this hardware implementation is not easily affected by other procedures, the oscilloscope can process data in parallel to achieve the receiver's DSP such as DDC, FFT, FIR, channelization and other algorithms of real-



capture. It is important to note that the concept of "real-time" is relative, meaning that the FFT processing speed must keep pace with the data acquisition rate to enable gap-free analysis of the data. Real-time spectrum analysis cannot capture every signal that appears, and the analysis capabilities vary among different real-time spectrum analyzers. Therefore, specific parameters are required to evaluate their performance.

The Probability of Intercept (POI) is a key parameter often used to assess the performance of real-time spectrum analyzers. Generally, the minimum signal duration for 100% POI is used to characterize the analyzer's ability to stably capture and measure signals. This implies that real-time spectrum analyzers have requirements for the signals they can capture—if the signal duration is shorter than the minimum duration for 100% POI, the analyzer cannot stably and accurately measure the signal. During the FFT processing, window functions must be applied to the acquired data points. However, this causes a reduction in the amplitude of data at the edges of each data frame due to the windowing effect. To address this, overlap processing is typically employed, with a 50% overlap scheme being commonly adopted. For example, with a 50% overlap, data points at the edge of one data frame will be positioned near the center of the adjacent data frame. This overlap strategy compensates for the loss of information at the frame edges caused by the window function while also reducing amplitude errors. As illustrated in Figure 7 under the 50% overlap condition, the signal duration must cover at least one full acquisition window to ensure accurate amplitude measurement.

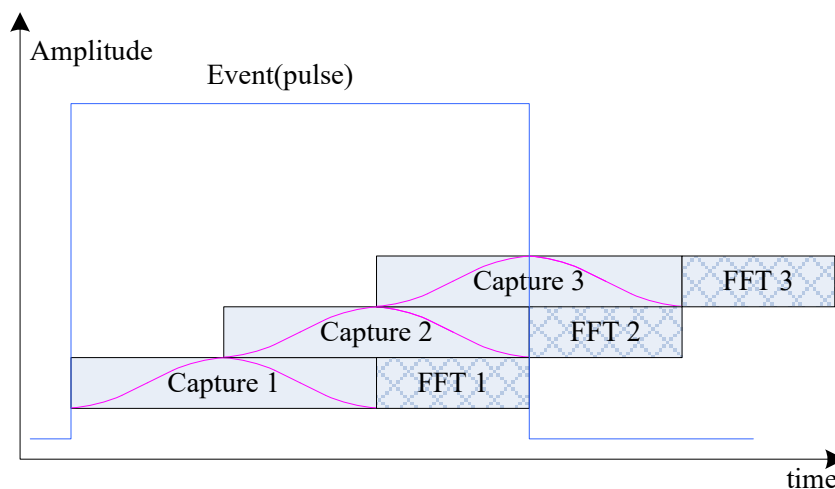

Figure 7 100% POI Minimum Signal Duration

In the RTSA function of the SDS7000A, when calculating the theoretical value for 100% POI with a span of 500 MHz, the FFT length is fixed at 2048 points, and the window width is adjustable. Using a window width of 2048 points, the signal must cover one complete FFT window. Without overlap, the required signal length is:

$$2048 + 2048 - 1 = 4095\text{pts}$$

After applying overlap processing with a 976 points overlap under a 500 MHz span and a sampling rate of 625 MHz, the 100% POI under these conditions is:

---

$$\frac{4095 - 976}{625} = 4990.4\text{ns}$$

Finally, we obtain the minimum duration of the 100% POI signal under overlap processing with a span of 500 MHz after calculation.

## Result Verification

After obtaining the theoretical 100% POI duration, we proceed to practical testing under the RTSA function to verify whether the corresponding signal can be captured and whether the amplitude measurement is accurate. We first use an RF signal generator to produce a pulse-modulated signal, controlling the signal duration by adjusting the pulse width. In the oscilloscope's RTSA mode, we set the span to 500 MHz and the sweep time to 50ms. The RF source is configured with a carrier frequency of 2 GHz, an output amplitude of -20dBm, and modulated with a single pulse. The pulse period is set to match the RTSA sweep time of 50ms, and the pulse width is adjusted to 30 $\mu$ s. At this point, we need to utilize the Frequency Mask Trigger(FMT) function, setting the trigger condition at the corresponding frequency based on the maximum power level of the input signal. If the signal is consistently captured across multiple attempts without any deviation in frequency and amplitude from the transmitted signal, it confirms that the set pulse width corresponds to the 100% POI metric. However, in practical testing environments, factors such as the RF source's output characteristics and cable losses can affect the power level. Using the RF source's set power value as the trigger condition may not guarantee stable triggering. In this case, we can increase the pulse width and observe the peak power of the signal measured by the oscilloscope's RTSA under longer durations. If the power remains stable before the duration decreases to the 100% POI time, this stable power value can be used as the trigger level for the Frequency Mask Trigger. The system will then trigger when the signal reaches this power level.

With testing, if the measured peak power remains consistent while the pulse width is increased to 50  $\mu$ s or decreased to 10 $\mu$ s, this power value can be definitively used as the trigger level for our Frequency Mask Trigger.

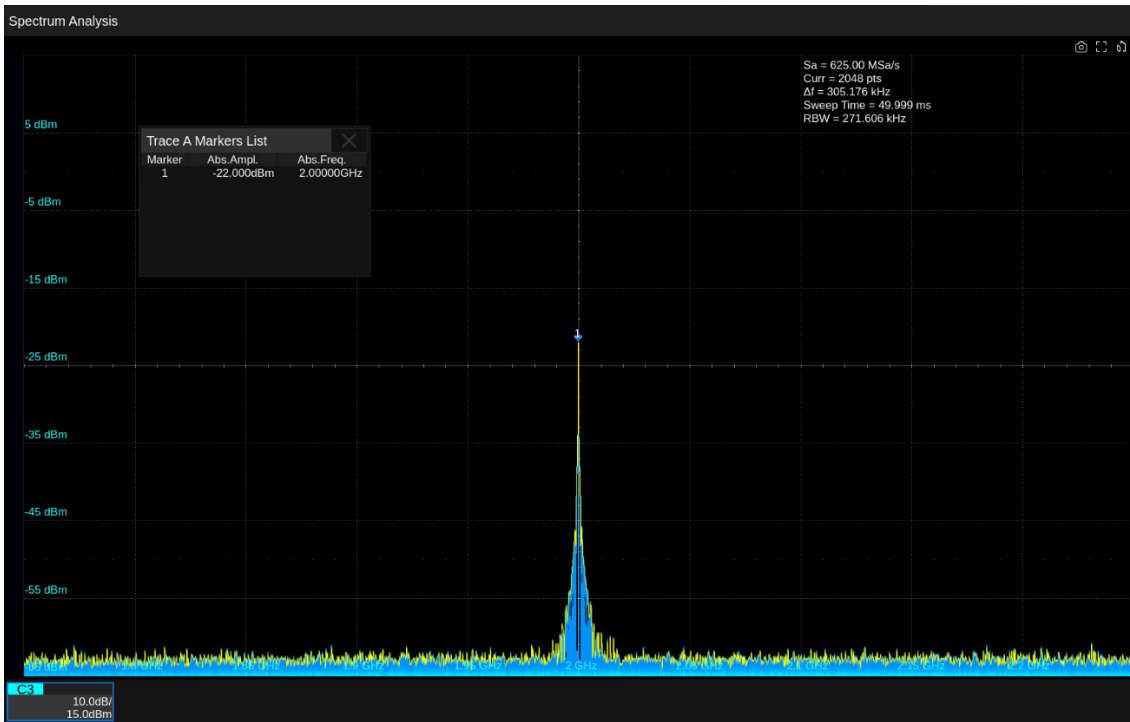

Figure 8 Amplitude of the Stable Signal

During the process of gradually reducing the pulse width for testing, when the signal pulse width reached  $4\mu\text{s}$  and below, a noticeable decrease in signal amplitude was observed from the RTSA interface. This indicates that the minimum duration for 100% POI is around  $4\mu\text{s}$ .

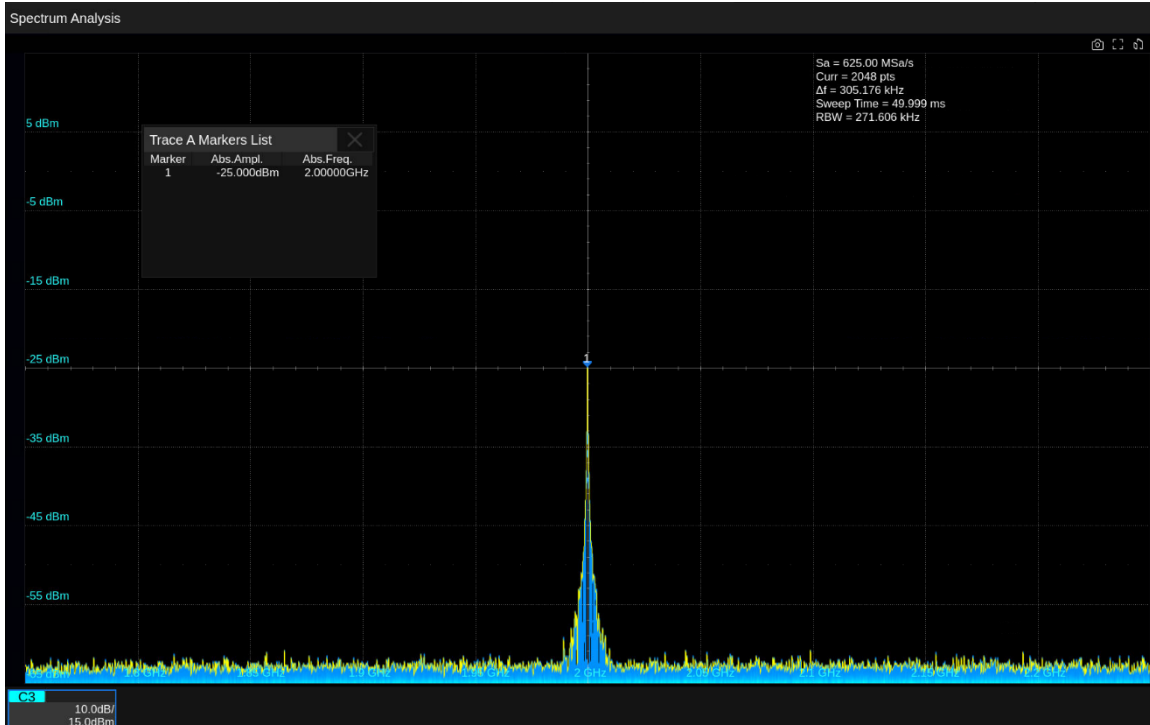

Figure 9 Amplitude of  $4\mu\text{s}$  Pulse Width Signal

At this point, the frequency mask trigger function can be utilized to set a corresponding mask for the signal under test to trigger the system. For demonstration purposes, this mask is set with a relatively wide frequency range, primarily to verify amplitude accuracy, and triggering can also be configured for a single

frequency point. By enabling both the frequency mask trigger and the mask trigger enable, and setting the trigger action to Stop, multiple runs are executed to check whether the signal can be stably triggered each time. When the pulse width is reduced to  $4.99\mu\text{s}$ , the system continues to trigger reliably on each signal occurrence, with the amplitude and frequency remaining consistent with the stable readings observed at higher pulse widths. This confirms that the minimum duration for 100% POI is reliably determined to be  $4990.4\text{ns}$ .



Figure 10 Pulse Configuration

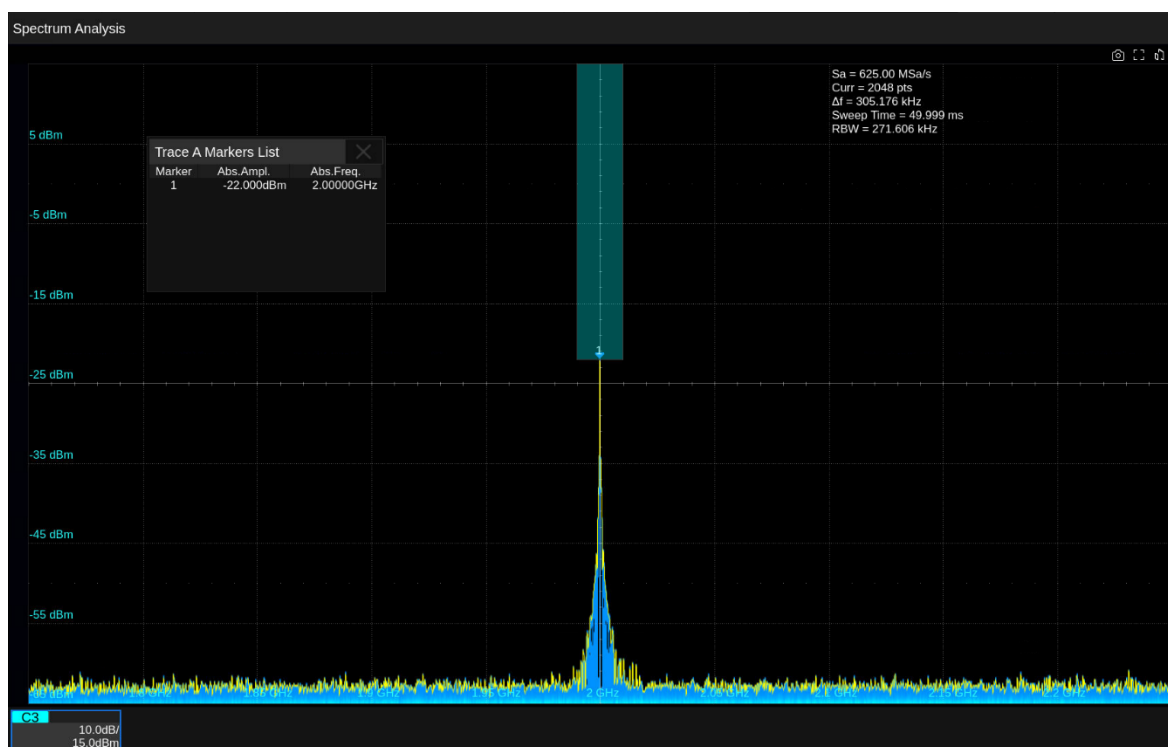

Figure 11  $4.99\mu\text{s}$  Pulse Width Stable Trigger Mask

## Functional Application

### Signal Analysis

With real-time spectrum analysis and digital down-conversion functions, the SDS7000A is not only capable of time-domain measurements, but also of high-precision measurements in the frequency domain, with higher bandwidths and higher-speed ADCs than traditional super heterodyne architecture spectrum analyzers, capturing transient burr signals, and acting as a signal analyzer thanks to the built-in SigVSA software function. It can be used as a signal analyzer with the built-in SigVSA software function. It can analyze the acquired signals with a maximum bandwidth of 2G, and has a wide range of measurement functions, from general-purpose OFDM signals to cellular protocol standard signals such as 4G LTE and 5G NR, and WLAN standard signals such as IEEE802.11b/a/g/n/ac/ax/be.



Figure 12 SigVSA Signal Analysis

### Multi-channel Synchronous Acquisition

Oscilloscopes are born with the characteristics of multi-channel synchronous acquisition, the delay between channels can be controlled at the level of picoseconds, and has the analysis bandwidth that is not possible with traditional spectrum analyzers. In the case of multiple inputs and multiple outputs, it is usually necessary to test at least four high-speed signals at the same time, in the oscilloscope equipped with offline analysis software SigScopeLab supports multiple oscilloscopes to cascade and display each channel in the software. MIMO transmitter testing requires multiple channels to be tested at once, while maintaining accurate time synchronization between them. When testing with a signal analyzer, one analyzer is used for each channel of the system under test and each analyzer is time synchronized. Oscilloscopes are equipped

with a large number of channels with low inter-channel jitter, and have a more advanced triggering system than spectrum and signal analyzers, which can accurately detect bursts of impulse signals and accurately detect the starting frequency of the impulse signals.

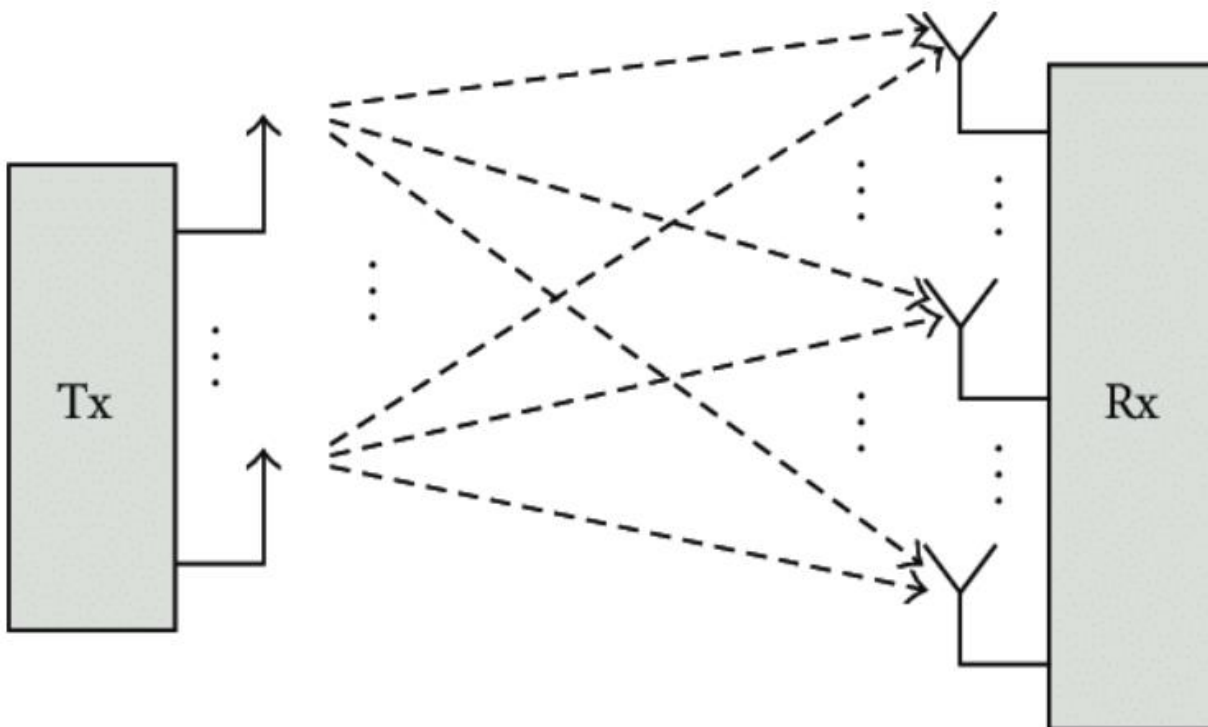

Figure 13 MIMO Test System

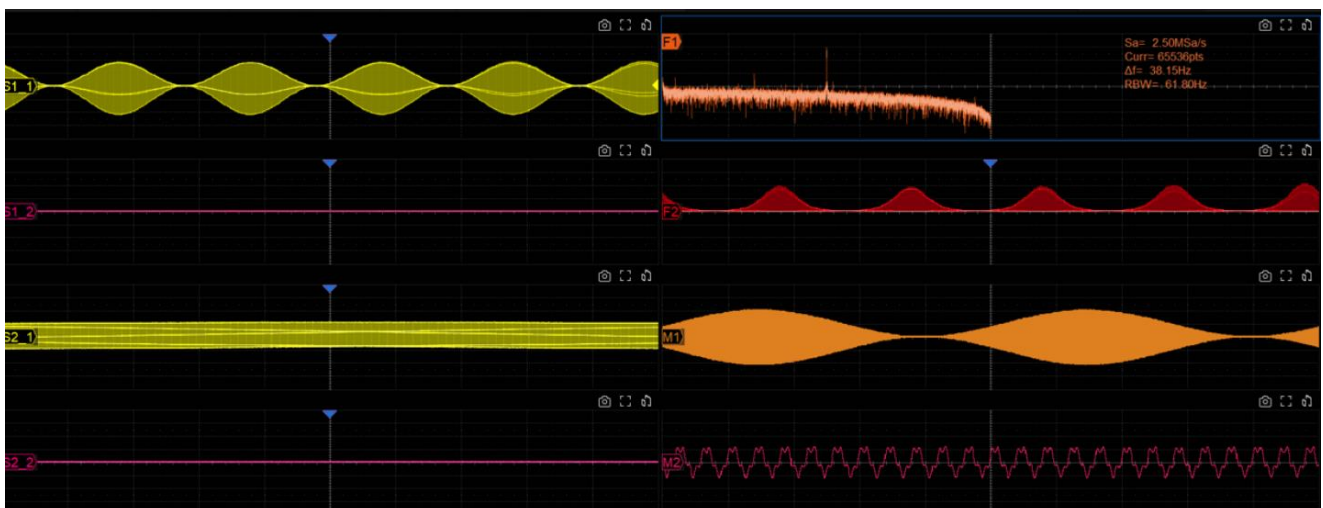

Figure 14 Multi-Channel Measurement Software

### EMI Pre-test

Products not only need to follow the EMC specifications in the design, but also to limit the EMI of the product to meet the standard requirements to complete the certification, EMI cannot affect the performance of the product itself, the optimization of the layout of the components used in the circuit design, high-frequency signal alignment design principles and differential signal processing, ground plane integrity design to reduce the ground loop and filtering and decoupling, and other operations are designed to

minimize electromagnetic interference, mainly in the noise source suppression, propagation path blocking, sensitive circuit protection and other measures.

In the EMI test analysis, usually use the spectrum analyzer for testing, but in fact the oscilloscope can also be used for EMI pre-test on the oscilloscope now uses a 12bit ADC, in the bandwidth range of the noise floor can be reduced to a lower degree, although does not have a spectrum meter pre-selector, EMI filters and pre-amplifiers and other devices, in the identification of the source of the radiation and analyze the reasons for it oscilloscopes can be used as a highly efficient tool. Compared with the traditional FFT function, the real-time spectrum analysis function can quickly set the frequency domain measurement parameters, and can also be triggered by the frequency template to locate the source of radiation, and can be combined with the waveform of the time-domain signal to better analyze and optimize the circuit design.

Oscilloscopes do not have a built-in EMI standard limit line, in the test we can use the template function, the template point to set up the EMI limit line function in order to disguise the radiation signal monitoring, encountered in the lower amplitude signals can also be used to increase the amplitude of the signal using an external pre-amplifier module.

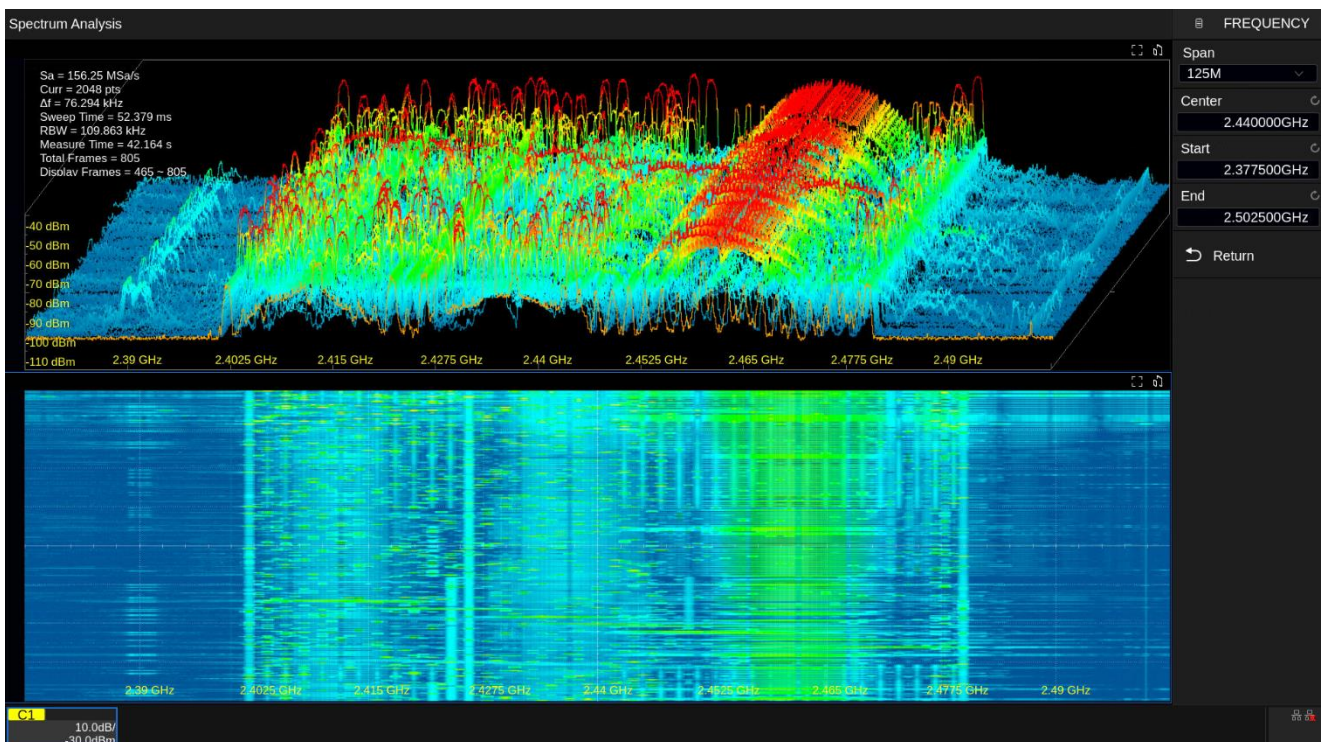

Figure 15 Real-time Monitoring of Radiation Signals

## Summary

The use of high-resolution real-time oscilloscopes for analysis, compared with the traditional spectrum, in the transient signal capture and real-time spectrum analysis has a unique advantage, and at the same time also through the built-in analysis software for the capture of the signal to analyze the parameters of the analysis and measurement, in the time domain and frequency domain of the signal under test, to be able to

---

take into account the functions of the signal analyzer, to better assist engineers to carry out product development and design. Although oscilloscopes are not as accurate as signal analyzers in analyzing signals with lower amplitude and bandwidth due to different operating principles, in the emerging high frequency measurement and millimeter wave technology, oscilloscopes can become a powerful measurement tool in millimeter wave testing thanks to their multi-channel acquisition capability and phase coherence.

## About SIGLENT

SIGLENT is an international high-tech company, concentrating on R&D, sales, production and services of electronic test & measurement instruments.

SIGLENT first began developing digital oscilloscopes independently in 2002. After more than a decade of continuous development, SIGLENT has extended its product line to include digital oscilloscopes, isolated handheld oscilloscopes, function/arbitrary waveform generators, RF/MW signal generators, spectrum analyzers, vector network analyzers, digital multimeters, DC power supplies, electronic loads and other general purpose test instrumentation. Since its first oscilloscope was launched in 2005, SIGLENT has become the fastest growing manufacturer of digital oscilloscopes. We firmly believe that today SIGLENT is the best value in electronic test & measurement.

### Headquarters:

SIGLENT Technologies Co., Ltd

Add: Bldg No.4 & No.5, Antongda Industrial Zone,  
3rd Liuxian Road, Bao'an District,  
Shenzhen, 518101, China

Tel: + 86 755 3688 7876

Fax: + 86 755 3359 1582

Email: [sales@siglent.com](mailto:sales@siglent.com)

Website: [int.siglent.com](http://int.siglent.com)

### North America:

SIGLENT Technologies America, Inc

6557 Cochran Rd Solon, Ohio 44139

Tel: 440-398-5800

Toll Free: 877-515-5551

Fax: 440-399-1211

Email: [info@siglentna.com](mailto:info@siglentna.com)

Website: [www.siglentna.com](http://www.siglentna.com)

### Europe:

SIGLENT Technologies Germany GmbH

Add: Staetzlinger Str. 70

86165 Augsburg, Germany

Tel: +49(0)-821-666 0 111 0

Follow us on  
Facebook: [SiglentTech](https://www.facebook.com/SiglentTech)

