

## Errata

**Title & Document Type:** 54111D Digitizing Oscilloscope Front-panel Reference Manual

**Manual Part Number:** 54111-90904E0388

**Revision Date:** March 1988

---

### HP References in this Manual

This manual may contain references to HP or Hewlett-Packard. Please note that Hewlett-Packard's former test and measurement, semiconductor products and chemical analysis businesses are now part of Agilent Technologies. We have made no changes to this manual copy. The HP XXXX referred to in this document is now the Agilent XXXX. For example, model number HP8648A is now model number Agilent 8648A.

### About this Manual

We've added this manual to the Agilent website in an effort to help you support your product. This manual provides the best information we could find. It may be incomplete or contain dated information, and the scan quality may not be ideal. If we find a better copy in the future, we will add it to the Agilent website.

### Support for Your Product

Agilent no longer sells or supports this product. You will find any other available product information on the Agilent Test & Measurement website:

[www.tm.agilent.com](http://www.tm.agilent.com)

Search for the model number of this product, and the resulting product page will guide you to any available information. Our service centers may be able to perform calibration if no repair parts are needed, but no other support from Agilent is available.

---

**Front-panel Reference Manual**

**HP 54111D Digitizing Oscilloscope**

---



© Copyright Hewlett Packard Company 1988

Manual Set Part Number 54111-90904E0388

Microfiche Part Number 54111-90804E0388

Printed in U.S.A. March 1988

---

## X-RAY RADIATION NOTICE

### ACHTUNG

Model 54111D

### WARNING

Während des Betriebs erzeugt dieses Gerät Röntgenstrahlung. Das Gerät ist so abgeschirmt, daß die Dosisleistung weniger als 36  $\mu\text{A kg (0,5 mR h)}$  in 5cm Abstand von der Oberfläche der Kathodenstrahlröhre beträgt. Somit sind die Sicherheitsbestimmungen verschiedener Länder, u.A. der deutschen Röntgenverordnung eingehalten.

Die Stärke der Röntgenstrahlung hängt im Wesentlichen von der Bauart der Kathodenstrahlröhre ab, sowie von den Spannungen, welche an dieser anliegen. Um einen sicheren Betrieb zu gewährleisten, dürfen die Einstellungen der Niederspannungs- und des Hochspannungsnetzteils nur nach der Anleitung in Kapitel V des Handbuchs vorgenommen werden.

Die Kathodenstrahlröhre darf nur durch die gleiche Type ersetzt werden. (Siehe Kapitel VI für HP - Ersatzteile)

Das Gerät ist in Deutschland zugelassen unter

der Nummer BW/218/86/ROE

When operating, this instrument emits x-rays; however, it is well shielded and meets safety and health requirements of various countries, such as the X-ray Radiation Act of Germany.

Radiation emitted by this instrument is less than 0.5 mR hr at a distance of five (5) centimeters from the surface of the cathode-ray tube. The x-ray radiation primarily depends on the characteristics of the cathode-ray tube and its associated low-voltage and high-voltage circuitry. To ensure safe operation of the instrument, adjust both the low-voltage and high-voltage power supplies as outlined in Section V of this manual (if applicable).

Replace the cathode-ray tube with an identical CRT only. Refer to Section VI for proper HP part number.

Number of German License BW/218/86/ROE



## GEWERBEAUFSICHTSAMT STUTTGART

- Zentrale Stelle für Sicherheitstechnik und Vorschriftenwesen in Baden-Württemberg -

□ Gewerbeaufsichtsamt, Jägerstr. 22, Postfach 703, 7000 Stuttgart 1 □

Stuttgart, den 16.01.1986

Fernsprecher

(07 11) 205 01 (Behördenzentrum)

Durchwahl 20 50 - 4798

Aktenzeichen: Z 5108/HP/Wa/Hh  
(Bitte bei Antwort angeben)

Firma  
Hewlett Packard GmbH  
Herrenberger Str. 110/130

7030 Böblingen

### Zulassungsschein Nr. BW/218/86/R8

Gemäß § 9 der Röntgenverordnung vom 01.03.1973 (BGBl. I S. 173) wird die Zulassung der Bauart durch den Bauartzulassungsbescheid vom 16.01.1986 mit Aktenzeichen Z 5108/HP/Ws/Hh für den nachfolgend aufgeführten Störstrahler bescheinigt:

Gegenstand	: Digital-Oszilloskop
Firmenbezeichnung	: HP Typ 54110D
Bildröhre	: Sony Typ M23 JHU 15X
Hersteller	: Hewlett-Packard 1900 Garden of the Gods Road Colorado Springs Colorado 80907, USA
Betriebsbedingungen	: Hochspannung: max. 22,3 kV Strahlstrom: max. 0,4 mA
Zulassungskennzeichen	: BW/218/86/R8

Die Bauartzulassung ist befristet bis 16.01.1996.

#### Für den Strahlenschutz wesentliche Merkmale

1. Die Art und Qualität der Bildröhre,
2. die der Hochspannungserzeugung und -stabilisierung dienenden Bauelemente.

Auflagen:

1. Die Geräte sind bezüglich der für den Strahlenschutz wesentlichen Merkmale entsprechend den vorgestellten und geprüften Mustern und Antragsunterlagen herzustellen.
2. Die Geräte sind einer Stückprüfung daraufhin zu unterziehen, ob sie bezüglich der für den Strahlenschutz wesentlichen Merkmale der Bauartzulassung entsprechen.

Die Prüfung muß umfassen:

- a) Kontrolle der Hochspannung an jedem einzelnen Gerät,
  - b) Messung und Dosisleistung nach Festlegung im Bauartzulassungsbescheid.
3. Die Herstellung und die Stückprüfung sind durch den von der Zulassungsbehörde bestimmten Sachverständigen überwachen zu lassen.
  4. Die Geräte sind deutlich sichtbar und dauerhaft mit dem Kennzeichen

BW/218/86/R8

zu versehen sowie mit einem Hinweis folgenden Mindestinhalts:

"Die in diesem Gerät entstehende Röntgenstrahlung ist ausreichend abgeschirmt.  
Beschleunigungsspannung maximal 22,3 kV."

Hinweis für den Benutzer des Geräts:

Unsachgemäße Eingriffe, insbesondere Verändern der Hochspannung oder Auswechseln der Bildröhre können dazu führen, daß Röntgenstrahlung in erheblicher Stärke auftritt. Ein so verändertes Gerät entspricht nicht mehr dieser Zulassung und darf infolgedessen nicht mehr betrieben werden.

*Reutter*

Reutter



"Das Digital-Oszilloskop HP Typ 54111D wurde mit Nachtrag 1 vom 02.07.86, Aktenzeichen Z 5108/Hewlett-Packard/Ws/Vg, in diese Bauartzulassung mit aufgenommen"

Dieses Gerät wurde nach den Auflagen der Zulassungsbehörde einer Stückprüfung unterzogen und entspricht in den für den Strahlenschutz wesentlichen Merkmalen der Bauartzulassung. Die Beschleunigungsspannung beträgt maximal 22,3 kV.

Hewlett-Packard  
1900 Garden of the Gods Road  
Colorado Springs  
Colorado 80907, USA

**Assistance** Product maintenance agreements and other customer assistance agreements are available for Hewlett-Packard products.

For any assistance, contact your nearest Hewlett-Packard Sales and Service Office. Addresses are provided at the back of this manual.

**Certification** Hewlett-Packard Company certifies that this product met its published specifications at the time of shipment from the factory. Hewlett-Packard further certifies that its calibration measurements are traceable to the United States National Bureau of Standards, to the extent allowed by the Bureau's calibration facility, and to the calibration facilities of other International Standards Organization members.

**Safety** This product has been designed and tested according to International Safety Requirements. To ensure safe operation and to keep the product safe, the information, cautions, and warnings in this manual must be heeded.

---

## Table of Contents

---

### Chapter 1: Introducing the HP 54111D Digitizing Oscilloscope

- 1-1 Introduction
  - 1-1 The HP 54111D's Key Features
  - 1-2 How To Use This Manual
- 

### Chapter 2: Basic Setup

- 2-1 Section Contents
  - 2-1 Operating Environment
  - 2-2 Power Requirements
  - 2-2 Applying Power
  - 2-4 Initial Color Display Setup
  - 2-4 List of Accessories
- 

### Chapter 3: Front-Panel Overview

- 3-1 Section Contents
- 3-1 Front-panel Organization
- 3-1 System Control
- 3-2 Clear Display Key
- 3-3 Run Key
- 3-3 Stop/Single Key
- 3-4 Save/Recall Setup Keys
- 3-6 Local Key
- 3-6 Auto-Scale Key
- 3-7 Entry Devices
- 3-8 Display and Section
- 3-9 Input Selection

---

## Table of Contents (Continued)

---

### Chapter 4:

#### Channel Menus

- 4-1 Section Contents
  - 4-1 Overview
  - 4-2 Display On/Off Key
  - 4-2 Volts/Div Key
  - 4-2 Offset Key
  - 4-3 Preset Key
  - 4-3 Input Coupling Key
- 

### Chapter 5:

#### Timebase Menu

- 5-1 Section Contents
  - 5-1 Overview
  - 5-2 Time/Div Key
  - 5-3 Delay Key
  - 5-4 Delay Reference Key
  - 5-4 Memory Bar
  - 5-6 Auto/Trg'd Sweep Key
  - 5-6 Auto-Sweep
  - 5-6 Triggered Sweep
  - 5-6 Status
  - 5-6 A/D Reference Calibration
- 

### Chapter 6:

#### Trigger Menu

- 6-1 Section Contents
- 6-1 Overview
- 6-3 How The Trigger Modes Overlap
- 6-3 Edge Trigger
- 6-6 Pattern Trigger
- 6-8 Pattern Trigger Exercise
- 6-9 Initial Setup
- 6-9 Instrument Setup
- 6-11 Pattern When Entered
- 6-13 Pattern When Exited
- 6-13 Time-qualified Pattern



---

## Table of Contents (Continued)

---

6-15	State Trigger
6-17	State Trigger Exercise
6-17	Initial Setup
6-18	Instrument Setup
6-19	Setting State Trigger
6-19	Time Trigger
6-21	Time Delay Trigger Exercise
6-21	Initial Setup
6-22	Instrument Setup
6-22	Setting Time Trigger
6-23	Event Trigger
6-25	Event Delay Trigger Exercise
6-26	Initial Setup
6-26	Setting Event Trigger

---

### Chapter 7:

#### Display Menu

7-1	Section Contents
7-1	Overview
7-2	Display Mode Key
7-4	Memory Bar Exercise
7-6	Resolution Key
7-7	Averaging Key
7-8	Persistence
7-8	Screen Key
7-9	Graticule Key
7-9	Single Shot Exercise
7-10	Initial/Instrument Setup
7-11	Single-Shot With Repetitive Display Mode
7-13	Zoom and Pan Exercise
7-14	Initial/Instrument Setup
7-15	Using The Zoom Feature
7-16	Zooming In
7-17	Panning

## Table of Contents (Continued)

---

### Chapter 8:

#### Delta V Menu

- 8-1 Section Contents
  - 8-1 Overview
  - 8-2 V Markers
  - 8-3 Preset Levels Key
  - 8-4 Preset Key and Source-to-Source Voltage Measurement
  - 8-4 Initial/Instrument Setup
  - 8-5 Source-to-Source Voltage Measurement
- 

### Chapter 9:

#### Delta t Menu

- 9-1 Section Contents
  - 9-1 Overview
  - 9-2 Start/Stop Markers
  - 9-3 Start/Stop On Edge
  - 9-4 Edge Find Key
  - 9-4 Time-interval Measurement Exercise
  - 9-4 Initial/Instrument Setup
- 

### Chapter 10:

#### Waveform Save Menu

- 10-1 Section Contents
- 10-1 Overview
- 10-3 Memory Selection
- 10-3 Pixel Memories
- 10-4 Waveform Memories
- 10-4 Display Key
- 10-4 Source For Store Key

---

## TABLE OF CONTENTS (Continued)

---

### Chapter 11: Waveform Math Menu

- 11-1 Section Contents
  - 11-1 The Menu
  - 11-1 Operation
  - 11-3 The Function Menu
  - 11-4 Function Scaling
  - 11-5 Vertical Scaling Units
  - 11-6 Math Function Definitions
  - 11-7 Function Display
  - 11-8 Waveform Math Exercise
- 

### Chapter 12: Measure Menu

- 12-1 Section Contents
  - 12-1 Overview
  - 12-3 Measure Key
  - 12-3 All Key
- 

### Chapter 13: Hardcopy Menu

- 13-1 Section Contents
  - 13-1 Configuring the System
  - 13-2 The Hardcopy Menu
  - 13-3 Printer Menu
  - 13-4 The Color Printer
  - 13-5 The Plotter Menu
- 

### Chapter 14: Utility Menu

- 14-1 Section Contents
- 14-1 Overview
- 14-2 Probe Menu
- 14-2 Overview
- 14-4 HP-IB Menu
- 14-4 EOI Key

## Table of Contents (Continued)

---

14-5	Cal Menu
14-5	Overview
14-7	ADC Reference Cal
14-9	Probe Tip Cal
14-11	Vertical Cal
14-12	Trigger Cal
14-13	Timebase Cal
14-20	Color Menu
14-20	Overview
14-20	Hue Key
14-21	Saturation Key
14-21	Luminosity Key
14-21	Default Setting Key

---

<b>Chapter 15</b>	<b>Specifications/Characteristics</b>
-------------------	---------------------------------------

---

<b>Appendix A:</b>	<b>Increasing Vertical Resolution</b>
--------------------	---------------------------------------

---

<b>Appendix B:</b>	<b>Inside the HP 54111D</b>
--------------------	-----------------------------

B-1	Hybrid Approach Overcomes Technology Barriers
B-3	Front End Technology Offers Performance and Versatility
B-3	GaAs Track and Hold Circuits for Silicon Converters
B-3	Deeper Memory with Another Internal HP Process

## Table of Contents (Continued)

---

### Appendix C:

#### Automatic Parametric Measurements

- C-1 Introduction
- C-1 Measurement Setup
- C-1 Making Measurements
- C-1 Automatic Top-Base
- C-2 Measurement Algorithms
- C-2 Frequency
- C-2 Period
- C-2 Duty Cycle
- C-3 Positive Pulse Width
- C-3 Negative Pulse Width
- C-3 Risetime
- C-3 Falltime
- C-3 Peak-to-Peak Voltage
- C-4 RMS Voltage
- C-4 Average Voltage
- C-4 Preshoot
- C-4 Overshoot

# 1

## INTRODUCING THE HP 54111D DIGITIZING OSCILLOSCOPE

---

### Introduction

The Hewlett-Packard 54111D digitizing oscilloscope provides a one gigasample/second digitizing rate, full HP-IB programmability, and a powerful feature set for a wide range of applications.

Not only does the HP 54111D allow you to make two-channel simultaneous, high speed single-shot capture, but its extensive feature set and repetitive sampling capabilities make it useful as a high-speed, general-purpose oscilloscope as well.

For extensive waveform evaluation, the HP 54111D provides four 8k deep memories that can be viewed and measured. In addition, such easy-to-use features as zoom and pan, and automated measurements are available at the press of a key.

---

### The HP 54111D's key features include:

- 1 gigasample/second digitizing rate
- 500 MHz repetitive bandwidth
- 250 MHz single-shot bandwidth
- 8k of acquisition memory per channel
- 10 waveform memories
- Vertical resolution up to eight bits with bandwidth limits
- Two-channel simultaneous capture at the full digitizing rate
- Pre and post trigger viewing capability
- Automatic triggering and display scaling
- Automatic waveform measurements
- Waveform math functions (A + B, A - B, invert)
- Ten front-panel setup save/recall registers
- General-purpose input coupling
- Digital triggering capabilities
- Functional-color display
- Hardcopy output to printer or plotter
- Fully programmable over the HP-IB

---

## **How To Use This Manual**

This manual is the most complete source of information concerning the front-panel operation of the HP 54111D. It contains a great deal of information that is not included in the *Setting Up the Oscilloscope* or *Getting Started* manuals, and it repeats important information presented in the other manuals so that you have one source of front-panel information after you are familiar with the instrument.

If you have not yet read *Setting Up the Oscilloscope*, you may want to do so at this time as it contains important installation instructions. To learn the basic operation of the HP 54111D, you may want to read the *Getting Started Guide* and then use this reference manual when you have questions regarding details of the scope's operation.

To help you find information quickly, this manual is divided into 15 sections plus three appendices, and, of course, the index.

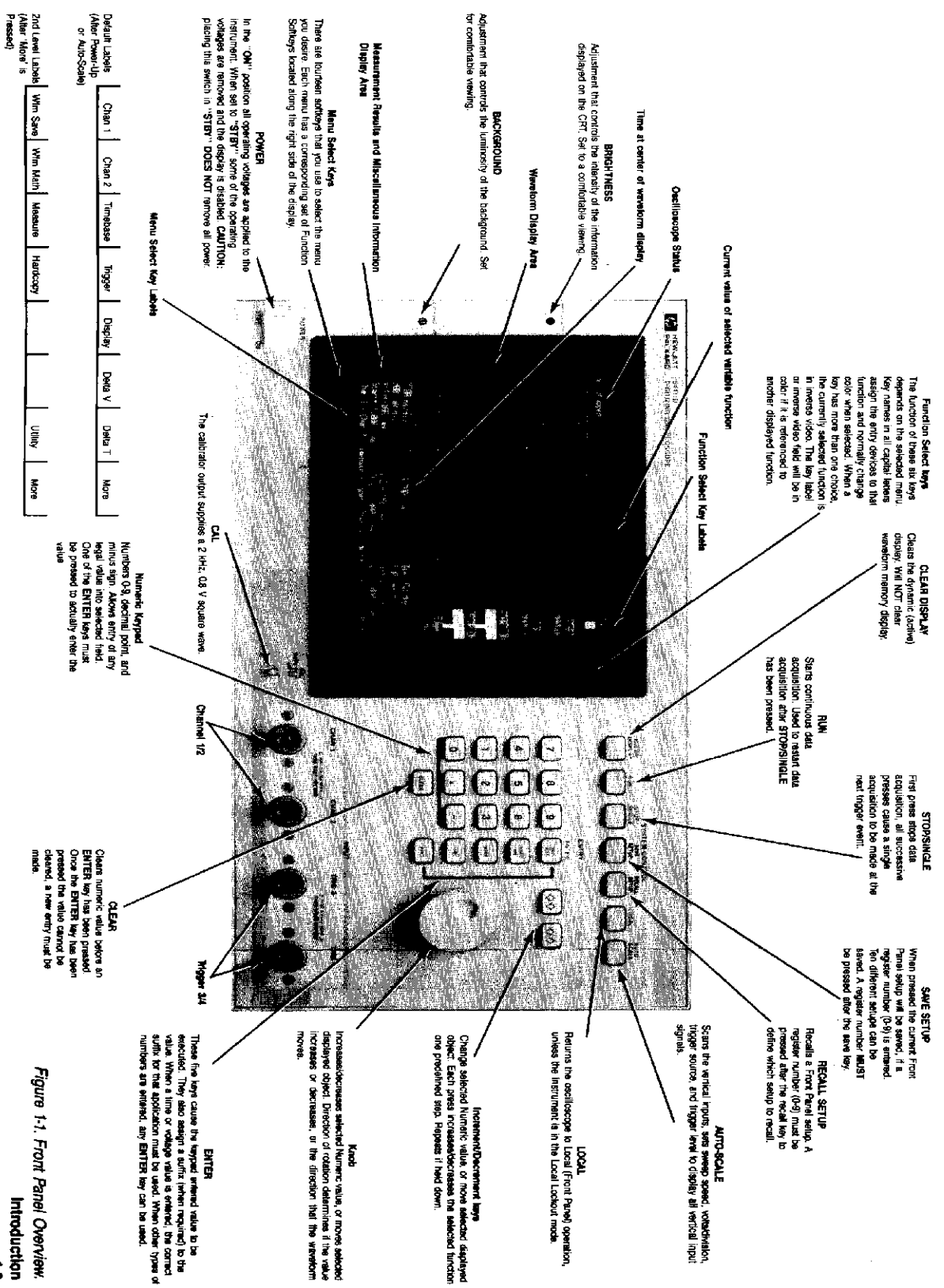

**Function Select Keys**  
The function of these six keys depends on the selected menu. Key names in all capital letters assign the entry devices to that function and normally change only when selected. When a key has more than one choice, the currently selected function is in red on the key label. The key label is on a menu video field will be in color if it is referenced to another displayed function.

**Time at center of waveform display**  
**BRIGHTNESS**  
Adjustment that controls the intensity of the information displayed on the CRT. Set to a comfortable viewing.

**Waveform Display Area**  
**BACKGROUND**  
Adjustment that controls the luminosity of the background. Set for comfortable viewing.

**Measurement Results and Miscellaneous Information Display Area**  
**Menu Select Keys**  
These are fourteen switches that you use to select the menu you desire. Each menu has a corresponding set of Function Switches located along the right side of the display.

**POWER**  
In the "ON" position all operating voltages are applied to the instrument. When set to "STBY" some of the operating voltages are removed and the display is disabled. **CAUTION:** Placing this switch in "STBY" DOES NOT remove all power.

**Function Select Key Labels**  
The currently selected function is in red on the key label. The key label is on a menu video field will be in color if it is referenced to another displayed function.

**CLEAR DISPLAY**  
Clears the graphic (soft) display. Will NOT clear waveform memory display.

**RUN**  
Sets continuous data acquisition. Used to restart data acquisition after STOP/SINGLE has been pressed.

**STOP/SINGLE**  
First press stops data acquisition; all successive presses cause a single acquisition to be made at the next trigger event.

**SAVE SETUP**  
When pressed the current front panel setup will be saved. If a register number (0-9) is entered, the different setup can be saved. A register number MUST be pressed after the save key.

**RECALL SETUP**  
Recalls a Front Panel setup. A register number (0-9) must be pressed after the recall key to define which setup to recall.

**AUTO-SCALE**  
Sets the vertical (y-axis) sweep speed, vertical position, trigger source, and trigger level to display all vertical input signals.

**LOCAL**  
Returns the instrument to Local (Front Panel) operation. Unless the instrument is in the Local Lockout mode.

**Increment/Decrement Keys**  
Change selected numeric value, or move selected object. Each press increases/decreases the selected function one predefined step. Flashes if held down.

**Keys**  
Increases/decreases selected numeric value, or moves selected displayed object. Direction of rotation determines if the value increases or decreases, or the direction that the waveform moves.

**ENTER**  
These five keys cause the keypad entered value to be executed. They also assign a suffix (when required) to the value. When a time or voltage value is entered, the correct suffix for that application must be used. When other types of numbers are entered, any ENTER key can be used.

**Channel 1/2**  
The calibrator output supplies a 2 MHz, 0.5 V square wave.

**Trigger**  
Numeric keypad. Numbers 0-9, decimal point, and minus sign. Shows entry of any right value. No selected item. One of the ENTER keys must be pressed to actually enter the value.

**Measure**  
Clears numeric value before an ENTER key has been pressed. Once the ENTER key has been pressed the value cannot be cleared; a new entry must be made.

**Utility**  
More

**More**

**Chan 1**  
**Chan 2**  
**Timebase**  
**Trigger**  
**Display**  
**Data V**  
**Data T**  
**More**

**When Save**  
**When Menu**  
**Measure**  
**Hardcopy**  
**Utility**  
**More**

**2nd Level Labels (After More is Pressed)**

Figure 1-1. Front Panel Overview.



# 2

## BASIC SETUP

---

### Section Contents

- Review of the power requirements, operating environment, and initial color display setup
- List of accessories provided with the instrument

#### WARNING

*It is important that you provide the correct power source and operating environment for this instrument. Failure to do this can cause serious damage to the instrument and/or provide a health hazard to the user.*

---

### Operating Environment

#### CAUTION

*Ensure that the instrument has adequate clearance on all surfaces to provide sufficient air flow for cooling. Do not block any of the vent holes on the fans' air inlet.*

The operating environment must be maintained within the following parameters:

Temperature ..... 15 degrees C to 55 degrees C  
Humidity ..... <95% up to 40 degrees C  
Altitude ..... <4572 metres (15 000 feet)

The instrument should be protected from temperature extremes that would cause condensation in the instrument.

---

## Power Requirements

The HP 54111D requires a power source of 115 or 230 Vac +15/-25%; 48-66 Hz single phase. Power consumption is approximately 350 watts maximum or 700 VA maximum. A screwdriver may be used to change the position of this switch.

### CAUTION

*Before connecting this instrument to the ac power source, ensure that the line select switch on the rear panel of the instrument is set to the correct voltage. This will avoid damage to the instrument.*

---

## Applying Power

The HP 54111D can be turned on after you have selected the correct setting on the line select switch, installed the appropriate power cord, and connected it to the power outlet. The circuit breaker trip current is 7.5 amps. The HP 54111D has two switches that can interrupt the power to the instrument. The first is the (mains) power breaker, the second is the STBY switch:

- the mains breaker is located in the upper right-hand corner of the rear panel.
- the STBY switch is located in the lower left-hand corner of the front panel.

If the front panel power switch is in the STBY position or if the mains breaker is in the OFF or "0" position, the HP 54111D will not function.

### WARNING

*If the mains breaker is in the ON or "1" position, electrical current is present inside the HP 54111D. This current could cause electrical shock and personal injury.*

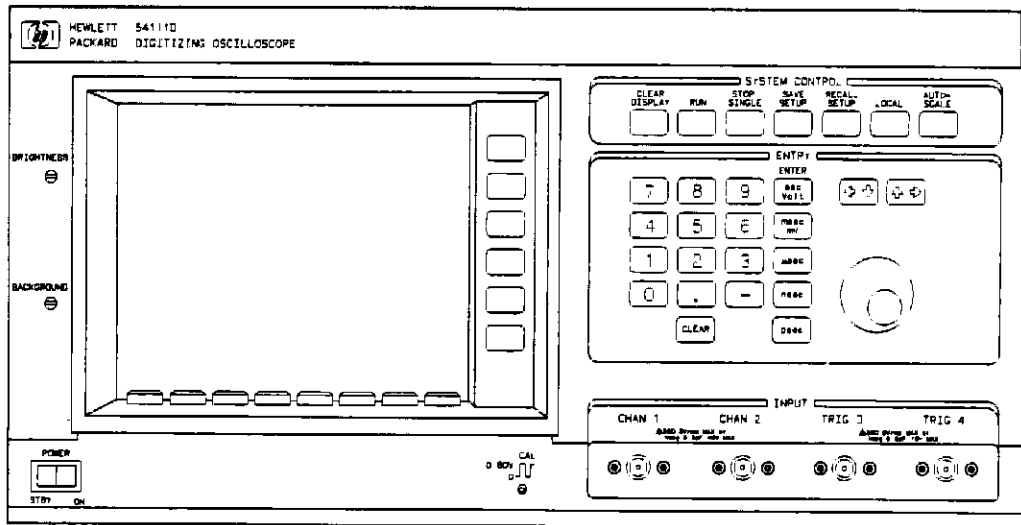

Figure 2-1. 54111D Front Panel

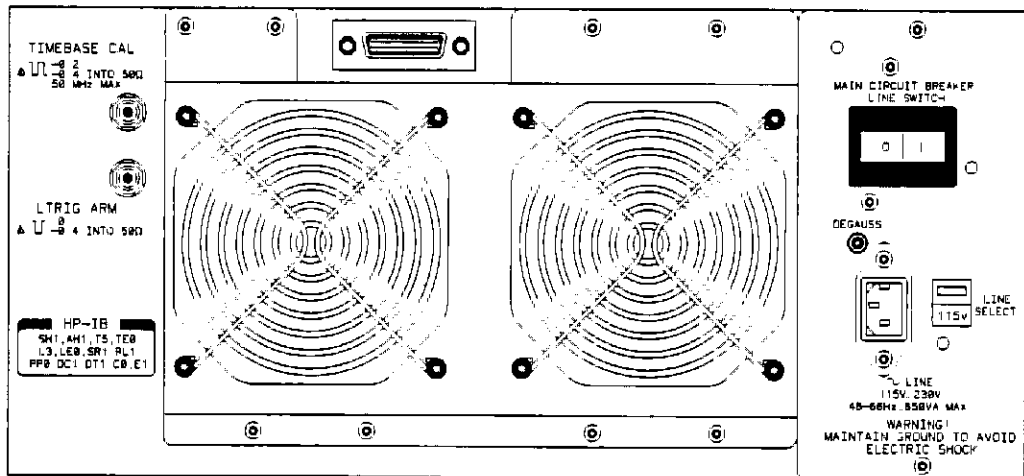

Figure 2-2. 54111D Rear Panel

---

## Initial Color Display Setup

The 54111D's electromagnetic color display may require degaussing (i.e., demagnetizing) at installation, or later if necessary. To facilitate this, the display section contains a degaussing coil. The degaussing switch is located on the rear-panel on the power panel. To degauss the CRT, press this switch several times.

Two screwdriver adjust controls for brightness and background are located on the front panel, to the left of the CRT. The background control sets the luminosity of the background of the CRT. The brightness control sets the gain of the Z axis (i.e., controls the intensity of the information displayed on the CRT). Adjust these controls to a comfortable setting.

---

## List of Accessories

In addition to any optional accessories you may have ordered, the HP 54111D is shipped with the following:

- two HP 10033A 10:1 miniature probes
- one power cable
- one operating manual, consisting of the following books:
  - *Getting Started Guide*
  - *Front-panel Operation Reference*
  - *Programming Reference Manual*
  - *Feeling Comfortable With Digitizing Oscilloscopes*
  - *Service Manual*

# 3

## FRONT-PANEL OVERVIEW

---

### Section Contents

– Description of the front-panel's functional areas and use of all of the single function keys

---

### Front-panel Organization

The HP 54111D has been designed for maximum ease-of-use. To this end, its front panel is separated into four functional areas. These are:

- System Control Section
- Entry Devices Section
- Display and Selection Section
- Input Section

You have complete local control of the instrument using these four areas.

---

### System Control

The SYSTEM CONTROL keys are located along the top right half of the front panel. These keys control acquisition, dynamic display, SAVE/RECALL SETUP registers, and automatic display scaling.

Throughout this section, references are made to several of the HP 54111D's twelve menus. Each menu has its own section in which it is discussed in full.

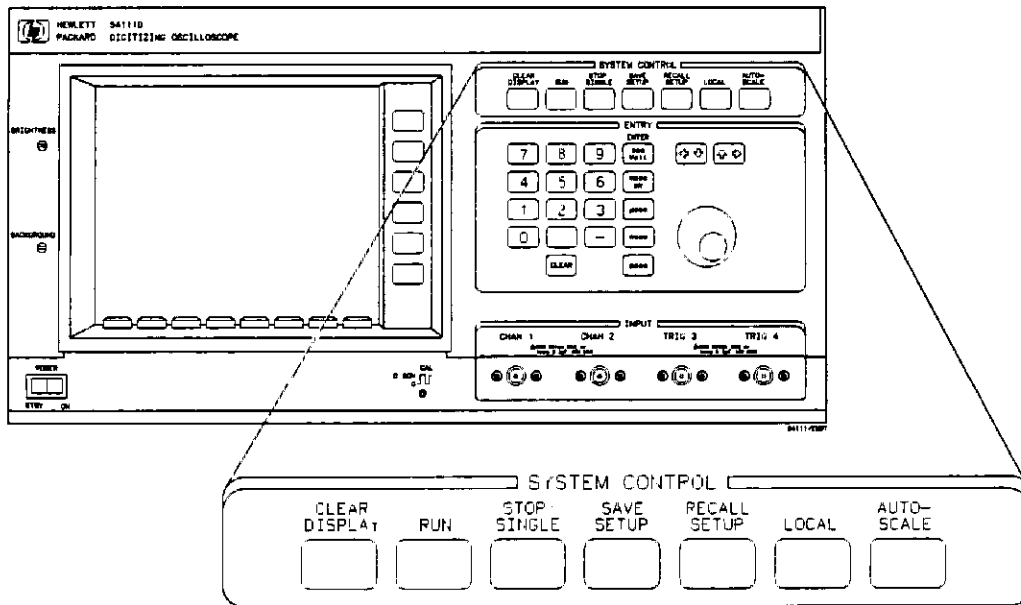

*Figure 3-1. System Control Keys.*

- Clear Display Key** Pressing the CLEAR DISPLAY key:
- causes the HP 54111D to momentarily stop acquiring data, erase the screen, and then resume acquiring data;
  - erases the dynamic (active) display;
  - does not erase a stored waveform that is being displayed;
  - if the STOP/SINGLE key is pressed before the CLEAR DISPLAY key is pressed:
    - the screen remains clear and waveform acquisition does not resume until the RUN key is pressed.

- 
- if a single acquisition is desired:
    - press the STOP/SINGLE key, then the CLEAR DISPLAY key, and then press the STOP/SINGLE key a second time.You can build up the display one acquisition at a time by continuing to press the STOP/SINGLE key (repetitive display mode\*\*).

If you have selected a high number of averages (repetitive display mode\*\*) and you change the input signal:

- you can quickly set the average registers to the new signal levels by pressing the CLEAR DISPLAY key.

This saves the time that the display normally requires to settle to the new signal levels in the average mode.

**Run Key** Pressing the RUN key:

- causes the HP 54111D to resume acquiring data after acquisition has been stopped by the STOP/SINGLE key.

**Stop/Single Key** When the STOP/SINGLE key is pressed:

- the instrument stops acquiring data and displays the last acquired data. Each subsequent STOP/SINGLE keypress arms the instrument to make a single acquisition at the next trigger event. To return to the previous operating mode, press the RUN key.

In the repetitive display mode\*\*, pressing the STOP/SINGLE key:

- erases the active display if you change the value of TIME/DIV, VOLTS/DIV, or any other front-panel control that rescales the displayed waveform (i.e., works as if the CLEAR DISPLAY key had been pressed).

While in the real-time display mode\*\*, pressing the STOP/SINGLE key:

- allows you to use the Timebase menu's TIME/DIV and DELAY functions to change the display.
  - TIME/DIV allows you to change the sweep speed (zoom).
  - DELAY allows you to pan the captured signal (pan)

\*\* The real-time and repetitive modes are discussed in Chapter 7, "Display Menu."

**Save/Recall Setup Keys**

The HP 54111D allows you to save and recall up to ten different front-panel setups in non-volatile memory. To save the current front-panel setup in one of the SAVE/RECALL SETUP registers:

- press SAVE SETUP, then press the number (0-9) of the register desired.

This saves all front-panel functions, modes, and color selections. This does not save menu selection and entry device assignments.

*Table 3-1. Values That Can Be Saved/Recalled.*

<b>Channel 1/Channel 2:</b>	Display VOLTS/DIV OFFSET Input Coupling Input Impedance
<b>Timebase:</b>	TIME/DIV DELAY Delay Reference Auto/Triggered Sweep
<b>Trigger:</b>	Mode Edge Mode - All Parameters Pattern Mode - All Parameters State Mode - All Parameters Time Mode - All Parameters Events Mode - All Parameters
<b>Display:</b>	Mode Resolution (Real Time Mode) Averaging (Repetitive Mode) Number of Averages (Repetitive Mode) DISPLAY TIME (Repetitive Mode) Screen Graticule
<b>Delta V:</b>	V Markers MARKER POSITIONS Preset/Variable Levels
<b>Delta T:</b>	T Markers START/STOP MARKER positions Edge Slopes Edge Numbers



Table 3-1. (continued)

<b>Wfm Save:</b>	Display (for each MEMORY) Source for Store (WAVEFORM MEMORIES)
<b>Wfm Math:</b>	Functions On/Off Function Definitions
<b>Measure:</b>	Source
<b>Hardcopy:</b>	Device Print Display (Printer) Print Factors (Printer) Form Feed (Printer) Auto Pen (Plotter) Pen Speed (Plotter)
<b>Utility:</b>	Probe Attenuation Factor Color Settings

**Note**

*The display does not change when you press SAVE SETUP. It does put the advisory, "Setup Saved," on the screen.*

Pressing SAVE/RECALL SETUP does not cause execution of action keys.

To recall a previously-saved front-panel setup:

- Press RECALL SETUP, then press the number (0-9) of the desired register.  
The advisory, "Setup recalled," will be displayed on the screen.

To return to the condition that existed before the last Auto-Scale:

- press RECALL SETUP, then press AUTO-SCALE.

To cancel a SAVE/RECALL SETUP:

- press the CLEAR key before entering a 0-9 number.

- Local Key** When the LOCAL key is pressed:
- an RTL (return to local) message is sent to the HP-IB interface, and the instrument returns to local (front-panel) control if it was under remote control and if the HP-IB controller had not invoked a local lockout.

The LOCAL key is the only front-panel key that is active when the HP 54111D is under remote operation.

- Auto-Scale Key** When the AUTO-SCALE key is pressed:
- the HP 54111D automatically selects the vertical sensitivity, vertical offset, trigger level, and sweep speed needed to display the input signal.
  - the HP 54111D sets itself to a known state by setting the delay reference to center screen, and delay to 0.

If input signals are present at both vertical inputs:

- the sweep is triggered on channel 1;
  - the display goes to the dual-screen mode; and
  - the vertical sensitivity and vertical offset for each channel are scaled appropriately.
- triggering will be set up internally on channel 1.

If only one of the vertical inputs has a signal on it:

- the display is in the single-screen mode.

When the AUTO-SCALE cycle is complete:

- the Timebase menu and TIME/DIV function are selected.

## Entry Devices

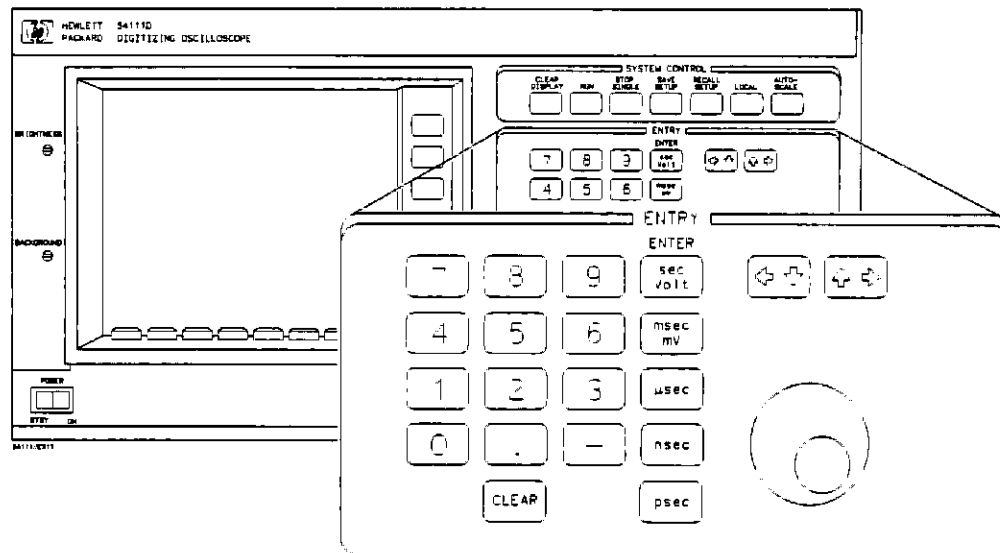

Figure 3-2. Entry Devices

Under the SYSTEM CONTROL keys is an area labeled ENTRY. Located in this portion of the front panel are the entry devices, which include:

- a number pad with a vertical column of five ENTER keys
  - after you enter a number, you must press one of the ENTER keys
- a knob
- an increment and a decrement key (step keys)

The entry devices are used to change the value of any of the items in the function menus that are displayed in capital letters (e.g., VOLTS/DIV and TIME/DIV).

## Display and Selection

Wfm Save	Wfm Math	Measure	Hardcopy			Utility	more
Chan 1	Chan 2	Timebase	Trigger	Display	Delta V	Delta t	more

54111/BL48

*Figure 3-3. Menu Selection.*

The display and selection section contain the CRT, two manual adjustments, menu selection keys, and function selection keys.

The two manual adjustments are located to the left of the display. These are the brightness and background adjustments. Adjust them to a comfortable viewing level.

The HP 54111D provides two sets of softkeys that enable you to control the instrument's front panel. They are the menu and function selection keys.

The first set (menu selection) is located across the bottom of the CRT:

- menu selection keys are used to choose a desired function menu;
- pressing a menu selection key changes the function select keys;
- pressing the More key (the key furthest right) provides an additional set of menu selections;
- pressing the More key a second time returns you to the original menu.

The second set (function selection) is located on the right-side of the CRT:

- some function keys are displayed in inverse video.
  - when pressed, the text in inverse video changes  
Example: pressing the top key when in the Trigger menu allows you to choose one of five trigger modes.
- some function keys are displayed in all capital letters.
  - when pressed, you can then use any of the entry devices to change the value of that function, and the value is displayed in the top center of the CRT.  
Example: pressing the TIME/DIV key when in the Timebase menu allows you to enter the sweep speed at which you want the input signal displayed.

- some function keys are displayed with the first letter of each word capitalized and the rest in lower-case.
  - when pressed, the function executes immediately.  
Example: pressing the All key in the Measure menu causes the oscilloscope to perform twelve parametric measurements on the designated waveform.

#### Note

*If the function select key allows you to select a waveform source, the text of the selected source is the same color as the source's waveform. For example, if the default colors are used, text relating to channel 1 is yellow and text relating to channel 2 is green.*

---

### Input Selection

This instrument has two vertical and two trigger inputs. All inputs have selectable input coupling and impedance. Each input's coupling and impedance can be set to ac at 1 M $\Omega$ , dc at 1 M $\Omega$ , dc at 50  $\Omega$  (not possible when using the HP 10033A probe), or ground. The triggers, however, cannot be set to ground.

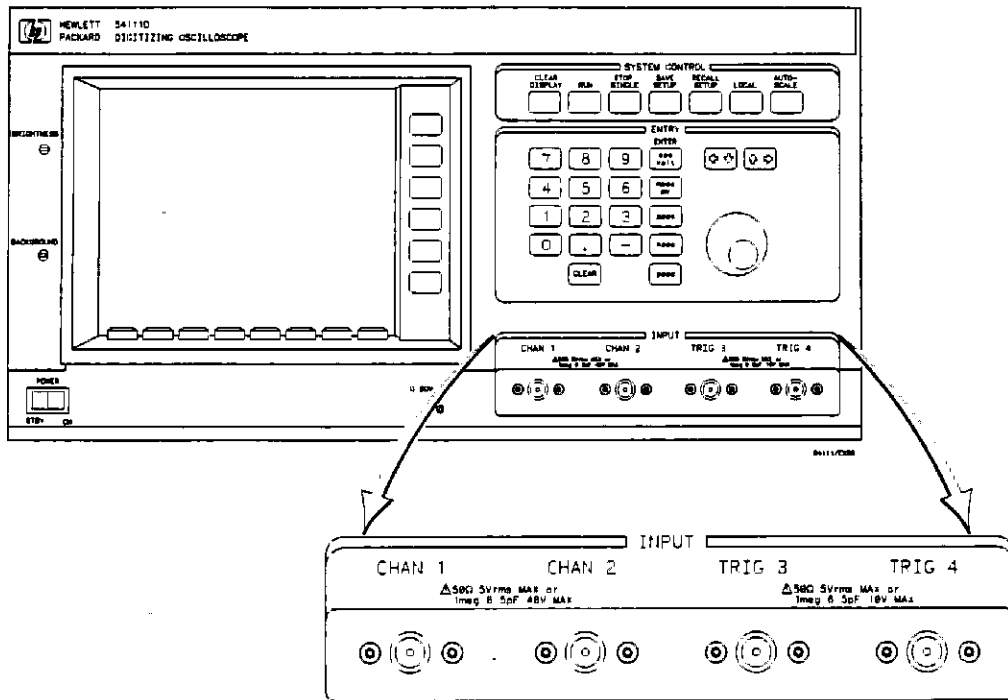

Figure 3-4 Input Selection.

# 4

## CHANNEL MENUS

### Section Contents

– Description of how these menus are used to control the vertical display, including vertical scaling and offset

### Overview

The channel menus (channel 1 and channel 2) allow you to control the vertical operation of the display as well as some of the HP 54111D's ease-of-use features, such as logic family presets.

The Chan 1 and Chan 2 menus are identical except for references to channels 1 and 2.

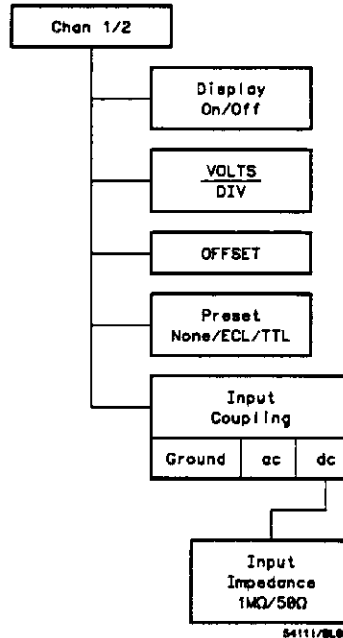
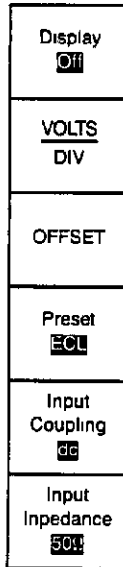

Figure 4-1. Channel 1/2 Menu.

When you select Chan 1 or Chan 2 (the two left-most softkeys in the menu selection area), either OFFSET or VOLTS/DIV is highlighted, indicating that that function can be changed using the entry devices.

---

### **Display On/Off Key**

Pressing the Display On/Off key:

- causes the selected channel signal to be displayed or not be displayed depending on whether On or Off is selected.

In the real-time mode, although this key turns off the display for a particular channel, it does not stop that channel from acquiring data. Turning off the channel (in both real-time and repetitive modes) increases throughput slightly as there is no post-processing of data. In the real-time display mode, you can view the data acquired while the display was off by turning the channel back on.

---

### **Volts/Div Key**

When the VOLTS/DIV key is selected, the vertical sensitivity of the channel can be changed using one of the three entry devices:

- using the number pad and appropriate units key results in sensitivity to three-digit resolution.
  - using the knob, you can increase sensitivity (3-2-1 sequence) by turning it clockwise, and decrease sensitivity (1-2-3 sequence) by turning it counterclockwise.
  - using the increment/decrement (step) keys changes sensitivity in a 1-2-5 sequence.
- 

### **Offset Key**

OFFSET allows you to move the trace up or down via the number pad, the knob, or the step keys.

This function works much the same way as an analog oscilloscope's vertical position control. However, because this oscilloscope has a true dc offset on the front-end, it provides a much wider offset range. The OFFSET voltage (referenced to the center of the waveform display) is shown at the top of the waveform display area.

---



---

### Preset key

Preset provides three choices:

- ECL – the HP 54111D automatically selects the offset, volts/div, trigger level, and input coupling to properly display logic family signals.
- TTL – the HP 54111D automatically selects the offset, volts/div, trigger level, and input coupling to properly display logic family signals.
- None – the HP 54111D returns to its previous settings.

	ECL	TTL
VOLTS/DIV**	200 mV	1 V
OFFSET	-1.3 V	1.6 V
Trigger level	-1.3 V	1.6 V
Input Coupling	dc	dc

\*\* These values are for a single screen display; appropriate values are used for dual and quad screen displays.

To select the desired preset, press the preset key until your selection is highlighted in inverse video.

---

### Input Coupling key

The Input Coupling for the selected channel may be set to:

- ac – the default input impedance is 1 M $\Omega$ .
- dc – the bottom key on the function menu becomes active and allows the choice of either 1 M $\Omega$  or 50  $\Omega$  input impedance.
- ground – a baseline is displayed showing the location of 0 V – the signal path is not actually grounded.

# 5

## TIMEBASE MENU

### Section Contents

– Description of how the Timebase menu is used to control the horizontal display.

### Overview

The Timebase menu, which is automatically selected after an AUTO-SCALE is performed, allows you to control the horizontal display through the TIME/DIV, DELAY, and Delay Reference functions. This menu also allows you to select a triggered function. It defaults to automatic trigger.

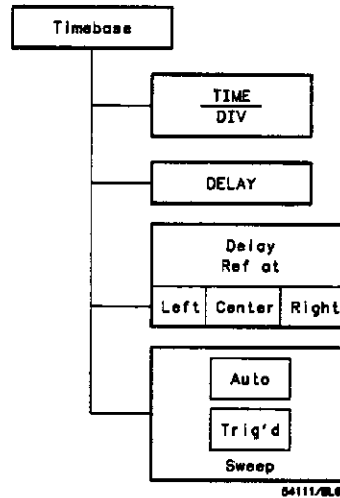
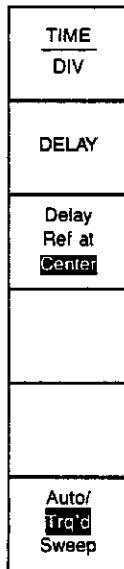

Figure 5-1. Timebase Menu.

---

## Time/Div Key

The TIME/DIV key allows you to vary the time scale on the horizontal axis from 1 s/div to 500 ps/div. This is located at the top of the function menu.

You can use any of the entry devices to vary this scale:

- using the number pad and appropriate ENTER key, the results in sensitivity can be adjusted with up to three digits of resolution.
- using the knob, you can change the sweep speed in a 1-2-5 sequence.
- using the increment/decrement keys, you can also change the sweep speed in a 1-2-5 sequence.

This key affects the sample rate at which the scope acquires data. The sample rate for the selected sweep speed is displayed to the right of the sweep speed setting.

In the real-time mode and with acquisition stopped, this key also controls the zoom feature (see Chapter 7, "Display Menu").

Sweep speed corresponds to sample rate according to the following table:

Sweep speed	Sample rate	Memory depth (real time only)
500 ps/div - 99.9 ns/div	1 gigasample/s	8.19 $\mu$ s
100 ns/div - 199 ns/div	500 megasamples/s	16.3 $\mu$ s
200 ns/div - 499 ns/div	250 megasamples/s	32.7 $\mu$ s
500 ns/div - 999 ns/div	100 megasamples/s	81.9 $\mu$ s
1 $\mu$ s/div - 1.99 $\mu$ s/div	50 megasamples/s	163 $\mu$ s
2 $\mu$ s/div - 4.99 $\mu$ s/div	25 megasamples/s	327 $\mu$ s
5 $\mu$ s/div - 9.99 $\mu$ s/div	10 megasamples/s	819 $\mu$ s
10 $\mu$ s/div - 19.9 $\mu$ s/div	5 megasamples/s	1.63 ms
20 $\mu$ s/div - 49.9 $\mu$ s/div	2.5 megasamples/s	3.27 ms
50 $\mu$ s/div - 99.9 $\mu$ s/div	1 megasamples/s	8.19 ms
100 $\mu$ s/div - 199 $\mu$ s/div	500 kilosamples/s	16.3 ms
200 $\mu$ s/div - 499 $\mu$ s/div	250 kilosamples/s	32.7 ms
500 $\mu$ s/div - 999 $\mu$ s/div	100 kilosamples/s	81.9 ms
1 ms/div - 1.99 ms/div	50 kilosamples/s	163 ms
2 ms/div - 4.99 ms/div	25 kilosamples/s	327 ms
5 ms/div - 9.99 ms/div	10 kilosamples/s	819 ms
10 ms/div - 19.9 ms/div	5 kilosamples/s	1.63 s
20 ms/div - 49.9 ms/div	2.5 kilosamples/s	3.27 s
50 ms/div - 99.9 ms/div	1 kilosamples/s	8.19 s
100 ms/div - 199 ms/div	500 samples/s	16.3 s
200 ms/div - 499 ms/div	250 samples/s	32.7 s
500 ms/div - 999 ms/div	100 samples/s	81.9 s
1 s/div	50 samples/s	163 s

### Delay Key

The DELAY key controls the pre-trigger and post-trigger delay and can be varied via the entry devices. The maximum pre/post-trigger delays change with sweep speed and the delay reference setting.

In the real time mode when acquisition is stopped, DELAY controls the pan feature (see Chapter 7, "Display Menu").

When the DELAY function is selected:

- delay time is displayed at the top of the waveform display area.
  - negative delay values indicate time before the trigger
  - positive delay values indicate time after the trigger
  - Delay = 0 means the trigger occurs at the delay reference point (right, left, or center of display)

---

### Delay Reference Key

The delay reference key (Delay Ref) allows you to reference the delay to the right or left graticule edge or center screen. In the real time mode, the display is referenced to the left/center/right of the entire 8k record.

- the time at the delay reference is equivalent to the delay time.
- Delay = 0 is the trigger point.

**Memory Bar** Only in the real time mode:

- a memory bar is displayed at the top of the waveform area.
- you can view 501 points on screen.

The memory bar baseline represents the entire waveform record. As the Delay Ref key is cycled, the memory bar moves from the left/right/center of the memory bar, echoing the Delay Ref key. This highlighted line segment shows you which portion of the waveform record is being displayed.

A "T" is also displayed along with the memory bar. The "T" shows where the trigger point is relative to the portion of the waveform being displayed. Increasing the delay time moves the "T" to the left, and decreasing delay time moves it to the right.

FOR MORE DETAILS...please refer to Chapter 7, "Display Menu," where the memory bar and "T" are discussed further.

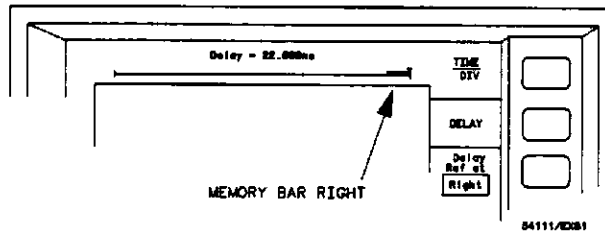
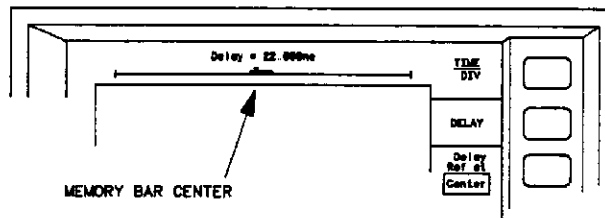
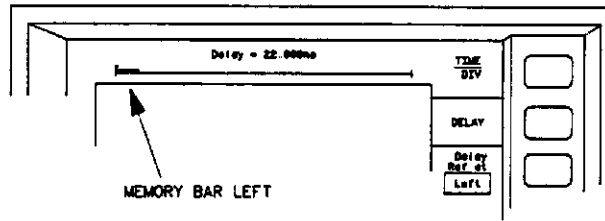

Figure 5-2. Memory Bar at Delay Left/Center/Right.

---

## Auto/Trg'd Sweep Key

**Auto-Sweep** If you choose auto sweep and there is not a signal input:

- the HP 54111D provides a baseline on the display.

If you choose auto sweep and there is a signal but it is not triggered:

- the display is unsynchronized, but a baseline is not provided.

**Triggered Sweep** Always use triggered sweep:

- if the trigger rep rate is slower than 50 Hz (as would be the case for long DELAY or large TIME/DIV settings).

If you choose triggered sweep and no trigger is present:

- the HP 54111D does not sweep, and the data acquired on the previous trigger remains on-screen.

Triggered sweep prevents the HP 54111D from generating a sweep before the trigger event. The displayed signal initiated by auto-sweep is asynchronous with the signal on the sweep initiated by the trigger event. The oscilloscope triggers normally if the trigger rep rate is faster than 50 Hz.

**Status** The STATUS line in the upper left-hand corner of the screen indicates the current trigger status. It is updated every half second.

In the triggered-sweep mode, the STATUS line indicates whether the instrument is "Running" or "Awaiting Trigger." In the auto-sweep mode, the STATUS line indicates whether the instrument is "Running" or "Auto Triggering." Other status indications are "Stopped," "Measuring," "Printing," "Plotting," and "Testing."

**A/D Reference Calibration** The HP 54111D automatically performs an A/D reference calibration on its A/D converters for both channels when the HP 54111D's operating system determines that this is needed. This feature provides consistent measurements without requiring you to make adjustments, and has been designed to not interfere with user measurements.

---

When the HP 54111D is awaiting a trigger, the A/D reference calibration is disabled. However, it is important to note that the HP 54111D's A/D references may drift while it is awaiting a trigger. If the ambient temperature is steady, drift is insignificant; drift becomes significant when the ambient temperature changes by more than 5 degrees F (2.5 degrees C) during the time when calibration is disabled.

There are two ways to avoid problems from this phenomenon:

- generally, it is sufficient to keep the HP 54111D in a "Stopped" status until 30 seconds before the trigger. While "Stopped," the HP 54111D will calibrate itself if RUN is pressed before an acquisition.
- perform an A/D reference calibration (see Chapter 14, "Utility Menu") just before setting the HP 54111D to trigger on the event. This procedure can be initiated over the bus under program control, by simulating key presses - see chapter 2 of the *HP 54111D Programming Reference Manual*, KEY command.

In computer-aided-test applications, the A/D reference calibration can be performed periodically during the test cycle to prevent interruption of tests by unplanned calibrations.

If important data is taken, you can determine the offset and reference calibrations by inserting dc signals at three divisions above and below center screen immediately after the acquisition. This data can be processed under computer control to remove the effects of any reference skew.



---

# 6

## TRIGGER MENU

---

### Section Contents

- Discussion of the oscilloscope's five trigger modes and two trigger inputs and two channel inputs that can be used as trigger inputs.
  - Examples involve pattern and state triggering as well as time-qualified and event-qualified triggering
- 

### Overview

The Trigger menu allows you to select the trigger modes. In each of the trigger modes you can select source, slope, and holdoff. In addition, this menu is your access to the HP 54111D's logic-pattern triggering capability.

The trigger menu provides five trigger modes:

- edge
- pattern
- state
- time-delay
- event-delay

These are accessed by pressing the Trigger Mode key (the top function key) until the mode you want is displayed in inverse video.

HP 54111D  
TRIGGER MENU  
TRIGGER MODE

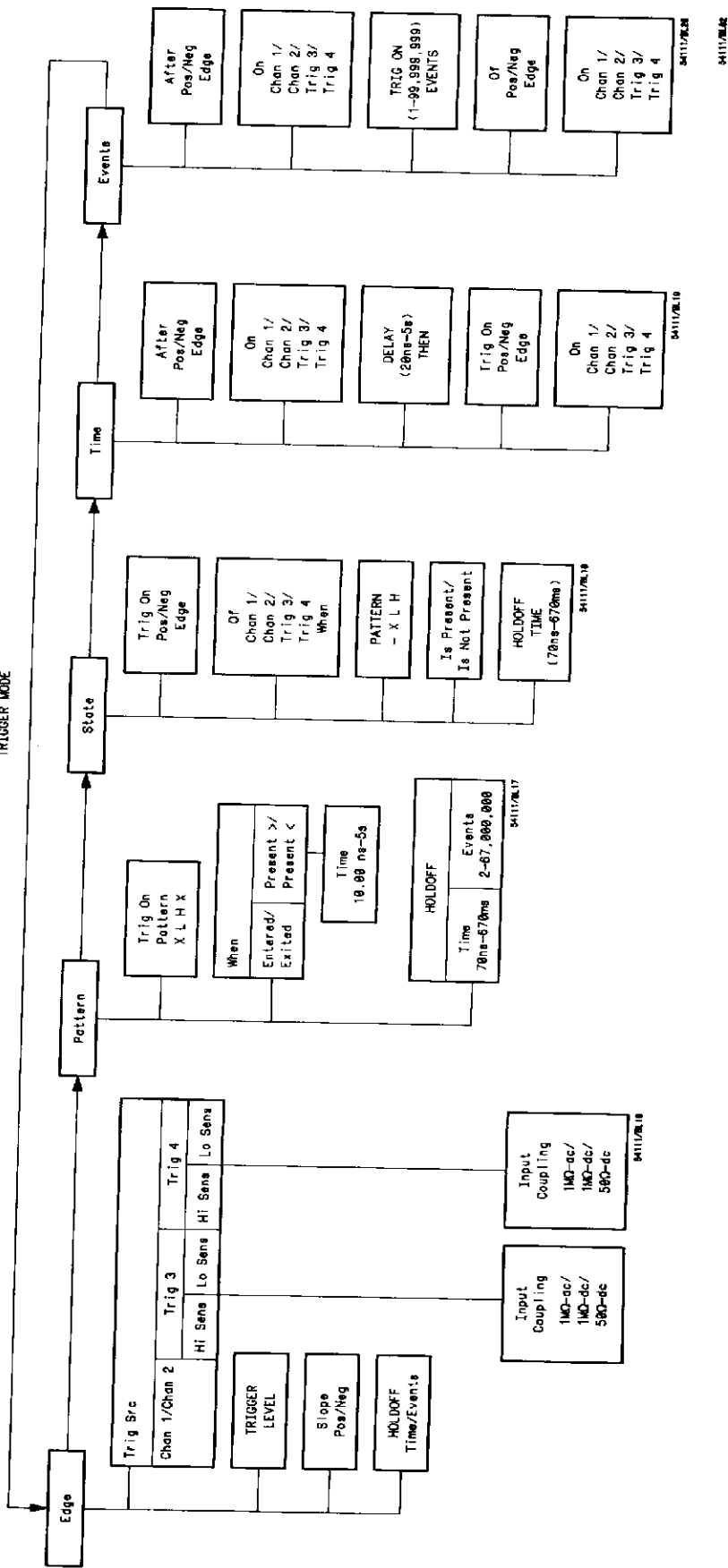

Figure 6-1. Complete Trigger Menu.

---

### How the Trigger Modes Overlap

TRIGGER LEVEL (i.e., threshold) is the only parameter that is passed unchanged from mode to mode once you have specified it (in the Edge Mode) — and this is done for each trigger source (Chan 1&2, Trig 3&4).

If the trigger repetition rate is below 50 Hz, always use the triggered-sweep function—see Timebase menu, Chapter 5, for more information. This prevents the oscilloscope from prematurely producing a trigger when there is a large event-delay count or delay time.

---

### Edge Trigger

The edge mode allows you to:

- select one of four trigger sources (Trig Src key);
- adjust the trigger level (TRIGGER LEVEL key);
- select the slope of the input signal that defines the trigger (Pos/Neg key);
- select the coupling, input impedance, and attenuation for the trigger sources 3 and 4; and
- define the HOLDOFF in time or events

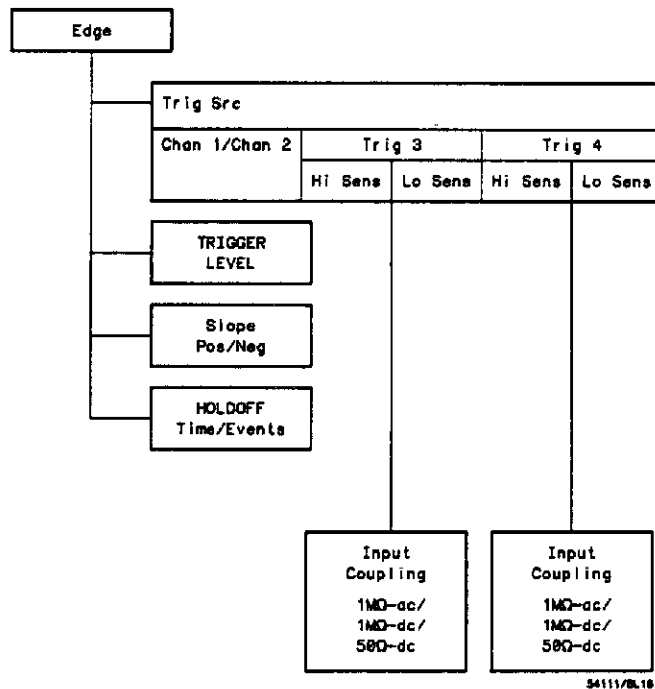

54111/01.10

Figure 6-2. Edge Menu.

**Trg Src Key** The Trig Src key permits you to select one of four trigger sources:

- Chan 1
- Chan 2
- Trig 3
- Trig 4

**TRIGGER LEVEL Key** If you select channel 1 or 2 as the trigger source and then press TRIGGER LEVEL:

- a horizontal line is displayed showing the trigger level with respect to the displayed signal.

**Slope Key** Press Slope to define the trigger as either the positive or negative slope of the input signal you select.

### Note

*Both the trigger slope and level can be set independently for each source and are retained even when another trigger source or mode is selected.*

- Coupling Key** If you select trigger source 3 or 4:
- you can choose from different maximum trigger sensitivities
  - set the coupling:
    - 50  $\Omega$  input impedance
      - dc is the default coupling
    - 1 M $\Omega$  input impedance
      - either ac or dc coupling can be selected
- HOLDOFF Key** Pressing the HOLDOFF function key allows you to:
- define the holdoff
    - as a period of time
    - as a number of events
      - an event is a change in the input that satisfies the trigger conditions
  - vary the holdoff using any of the entry devices.

Simply stated, holdoff means that you can disable the oscilloscope's trigger circuit for a definable period of time or number of events after a trigger event occurs. If selected, the holdoff is displayed at the top of the waveform display area.

If you select HOLDOFF Time:

- you can define a holdoff from 70 ns to 670 ms.

For holdoff-by-time values >50 ms and holdoff-by-events values that cause a holdoff time >50 ms:

- use the triggered sweep function (see Timebase menu, chapter 5)

If you select HOLDOFF Events:

- you can define a holdoff from two events to 67,000,000 events. Maximum counting rate for events is 80 MHz.
- you can trigger stably on a complex waveform by counting the number of trigger events that are to be skipped before accepting the next for a trigger. Setting the holdoff to one less than the number of events occurring over the fundamental period yields a stable display.

Holdoff-by-events is equivalent to placing a divide-by-N counter in the trigger path where N is the holdoff value.

### Note

*Unlike older analog oscilloscopes, the HP 54111D's trigger system is completely independent of the timebase. This means that adjusting the DELAY or TIME/DIV function does not disturb the display synchronization established with holdoff.*

---

## Pattern Trigger

The pattern mode allows you to:

- set up the HP 54111D to recognize a four-bit pattern and trigger:
  - when entering,
  - when exiting, or
  - when pattern is present for a specified amount of time

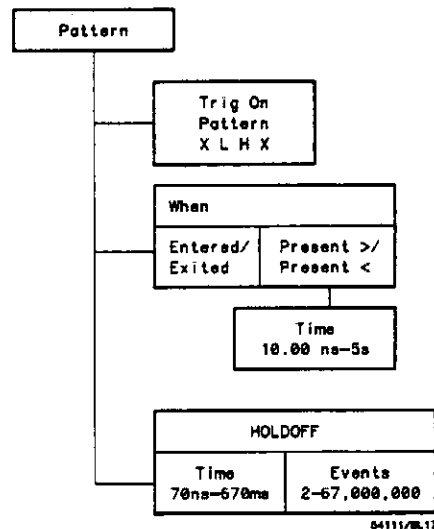

Figure 6-3. Pattern Menu.

**Trig On  
PATTERN Key**

Pressing the Trig On PATTERN key:

- highlights one of four characters that are displayed in inverse video.
  - the four characters are referred to as channel 1, channel 2, trigger input 3, and trigger input 4, respectively.

Use one of the entry devices to change this character to one of three letters:

- X – is a “don't care” condition (i.e., a bit with an X means that the associated input is not used as a trigger qualifier).
- L – requires an input less than the trigger level of that input.
- H – requires an input greater the trigger level of that input.

For example, if the pattern is “LHXX,” then the voltage on the channel 1 signal must be below the trigger level set up for channel 1 and the voltage on the channel 2 signal must be above the trigger level set up for channel 2 to satisfy the pattern condition. The signals on trigger inputs 3 and 4 are ignored as they are set to the “don't care” condition.

The condition for the input associated with the highlighted bit is displayed at the top of the waveform display area.

**Note**

*Set the TRIGGER LEVEL for each trigger source while you are in the edge mode. These trigger levels must be set before going to the pattern mode or proper pattern triggering may not occur.*

**When Entered/  
Exited/ Present>/  
Present< Key**

When you press the When key:

- the inverse video text field next to the key changes from:
  - Entered
  - to Exited
  - to Present >
  - to Present <

If Entered is selected:

- the HP 54111D triggers on the last transition that makes the PATTERN true.

If Exited is selected:

- the HP 54111D triggers on the first transition on any of the Inputs that cause the PATTERN to be false, after it has been true.

If Present > is selected:

- a TIME key is added to the Pattern menu that allows you to:
  - specify a minimum time period from 10 ns to 5 seconds using any one of the entry devices.
- a trigger event occurs when:
  - the PATTERN becomes false after being true for the minimum time period.

If the pattern becomes true and then goes false before the specified time, a trigger does not occur.

When Present < is selected:

- a trigger occurs only if the trigger pattern is true and then becomes false before the specified time period has elapsed.
- the pattern must be true for at least 1 ns to be recognized.
- the trigger occurs at the first transition that makes the pattern false.

**HOLDOFF** Pressing **HOLDOFF**:

- Key**
- allows you to specify the holdoff you desire in either events or time.

Refer to page 6-5 for a complete description of **HOLDOFF** and the range of values that are valid.

---

## **Pattern Trigger Exercise**

This exercise demonstrates how the input signals can be used in combination to generate a trigger.

Pattern triggering is extremely valuable when you are testing digital circuitry and must qualify an acquisition with signals from more than one source.

The equipment required to complete this exercise includes:

- HP 54111D oscilloscope
- HP 8116A function generator
- BNC tee
- two one-metre coaxial cables



You may use another function generator as long as it is capable of providing:

- variable width
- 10 MHz
- 2 V output
- <5 ns rise/fall time
- minimum pulse width of 10 ns

**Initial Setup** Set up the instruments by:

- connecting the BNC tee to channel 1 of the HP 54111D;
- connecting one cable from the output of the function generator to the BNC tee on channel 1;
- connecting the other cable from channel 2 to the other side of the BNC tee;

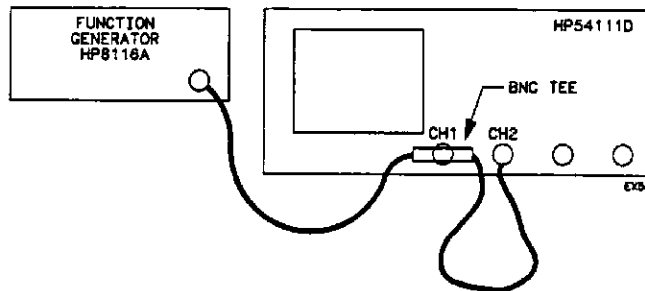

*Figure 6-4. Equipment Connection*

The unequal cable lengths between the function generator and channel 1 and 2 provide a time differential between the signals displayed on the oscilloscope. The amount of propagation delay that is generated by a one metre cable is approximately 6 to 7 ns. The delay between channels is used to demonstrate the triggering capability of the HP 54111D.

**Instrument Setup** Set the function generator controls as follows:

- Function = Pulse
- Frequency = 10 MHz
- Width = 50 ns
- Amplitude = 2 V
- Offset = 0 V

If you are using an HP 8116A function generator, ensure that the "DISABLE" light is off.

After pressing the AUTO-SCALE key on the HP 54111D, set the controls as follows:

- Timebase menu  
TIME/DIV = 5 ns/div  
Sweep mode = Trg'd
- Display menu  
Display = Single Screen  
Graticule = Axes
- Chan 1 & 2 menus  
Channel 1 & 2 offset = 0  
Channel 1 & 2 coupling = dc  
Channel 1 & 2 input impedance = 50  $\Omega$   
Channel 1 & 2 VOLTS/DIV = 200 mV/div
- Trigger menu  
TRIGGER LEVEL for Chan 1 and Chan 2 = 0 (set  
TRIGGER LEVEL in the edge trigger mode)  
Trig Src = Chan 1

After the setup is complete the oscilloscope should be triggering on the positive edge of channel 1.

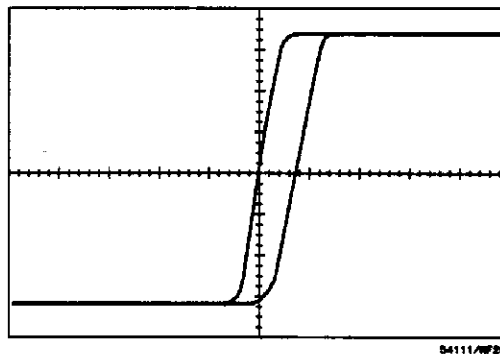

Figure 6-5. Pattern Trigger Waveform.

### Pattern When Entered

- select the Trigger menu
- select the Pattern Trigger Mode
  - you should only have to press the trigger mode key once to move the HP 54111D from the edge to the pattern mode.
- select “When Entered”
  - this causes the HP 54111D to generate a trigger on the edge that makes the trigger pattern true.

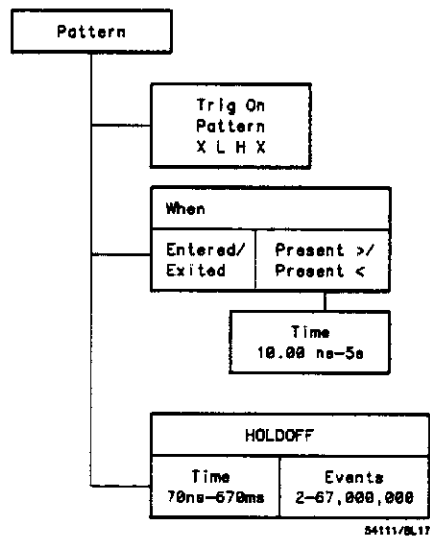
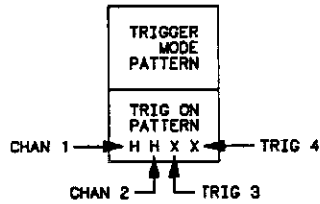

Figure 6-6. Pattern Menu.

In the pattern trigger mode, the HP 54111D can trigger when entering or exiting a pattern.

The Trig On Pattern key allows you to define a pattern that is used to trigger the oscilloscope. For this exercise use HHXX. H indicates high, and X indicates a “don’t care” condition.



54111/EX09

Figure 6-7. Setting the Pattern.

This pattern requires that the signals on channel 1 and 2 must be positive with respect to the trigger level in order to generate a trigger.

When you set up the oscilloscope for this exercise, the trigger level for channels 1 and 2 were set to 0 V. This means that the last input, either on channel 1 or 2 that goes above 0 V generates a trigger.

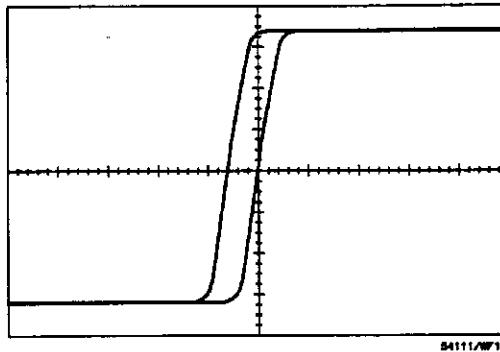

54111/WF11

Figure 6-8. Pattern HHXX Waveform.

In this exercise, you referenced the trigger event to center screen. Notice that the signal from channel 2 crosses center screen at the 0 V level. This crossing completes the requirement for the trigger event.

**Pattern When Exited** You can also set up the HP 54111D to trigger on the first edge that makes the trigger pattern false by pressing the When key and selecting "Exited" as the variable. In this example, the first edge to make the pattern false is the negative edge from channel 1.

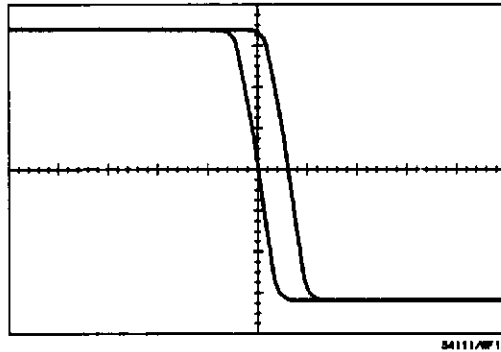

*Figure 6-9. Waveform for Pattern HHXX When Exited.*

**Time-qualified Pattern** Along with the ability to trigger on the exit or entry of a pattern, the HP 54111D can qualify a pattern trigger with time. You may set the oscilloscope to trigger on a pattern that has been present for a minimum or maximum period of time by selecting the When Present > (greater than) or < (less than) function.

Applications for this trigger mode include:

- glitch detection
- triggering on timing violations
- capturing bus hangup conditions

For the HP 54111D to generate a trigger when it is in the When Present > mode:

- the pattern must be present for a minimum period of time, between 10 ns and 5 seconds; and
- one of the pattern sources must change, causing the pattern to be invalid.

The minimum time period available is 10 ns, and the maximum is 5 seconds.

Select the When Present > function and set time = 10 ns (if it isn't already).

With the HP 54111D in this configuration:

- it will trigger on the first edge that causes pattern HHXX to be false after it has been present for a minimum of 10 ns.
- from the time that channel 2 satisfies the trigger until channel 1 goes false is 50 - 55 ns.
- this allows the HP 54111D to trigger on the negative edge of channel 1 the same way it did when you used the When Exited mode.

Select the When Present < function and notice that the signals are no longer displayed and the prompt in the upper left corner of the display indicates the instrument is "Awaiting a Trigger."

For the HP 54111D to trigger in the When Present < mode, the pattern must be valid for a shorter period of time than specified by the time variable, in this case 10 ns.

In this example, to generate a trigger, channels 1 and 2 must transition to a high state. Then one of them must invalidate the pattern by moving to a low state within 10 ns of the edge that originally made the pattern true.

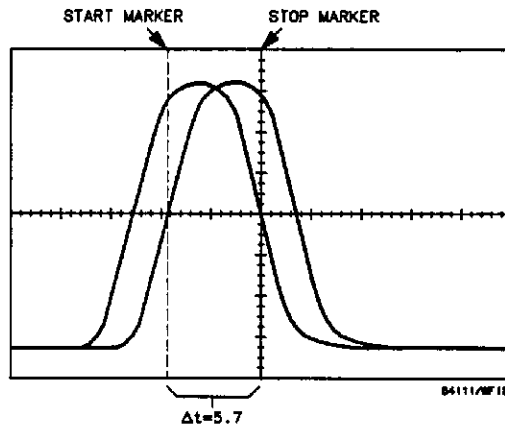

Figure 6-10. Waveform With 5.7 ns Overlap.

Using the vernier keys on the function generator:

- set the pulse width to 10 ns
  - with the pulse set this narrow, the period of time that channels 1 and 2 satisfy the pattern requirements is about 3 ns (i.e., less than the 10 ns time qualifier)
  - the oscilloscope starts triggering and the trace returns to the display.
- increase the pulse width in 1 ns increments until the instrument stops triggering:
  - the oscilloscope should stop triggering when the pattern is validated for more than 10 ns, at about 15 ns pulse width.
  - at this point, channels 1 and 2 validate the pattern for more than 10 ns and the trigger conditions are not met.

---

## State Trigger

The State mode allows you to:

- select one of the inputs as a simple edge source (clock), and use the other three to define a pattern (X, L, or H as in the pattern mode).

### Trig On Pos/Neg Edge Key

Pressing the Trig On Pos/Neg Edge key:

- selects the polarity of the edge of the clock source as the trigger.

### Of Key

Pressing the Of key:

- selects the clock source (Chan 1, Chan 2, Trig 3, or Trig 4)
  - notice that as you press the Of key the PATTERN key variables change.
  - the “-” in the pattern shows which source is being used as the edge source or clock.

### Pattern Key

Pressing the PATTERN key:

- allows the three remaining inputs to be set: - to H (high), L (low), or X (don't care). - to define the logic pattern that is used to qualify the clock edge.

### Is/Is Not Key

Pressing the Is/Is Not Present key:

- determines if the pattern must be present or must not be present to qualify the clock edge as a trigger.

The thresholds for each input of the pattern are those you set with TRIGGER LEVEL in the edge mode.

Limitations of state mode:

- maximum clock speed is 80 MHz.
- only holdoff-by-time is available.

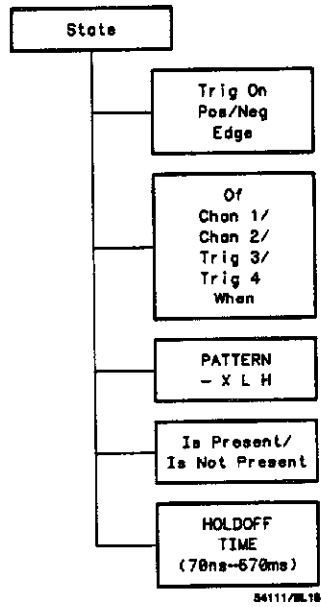

Figure 6-11. State Menu.



## State Trigger Exercise

This exercise demonstrates how an input pattern can be used to qualify a clock edge that is to be used as a trigger.

State triggering extends the logic triggering capability of the HP 54111D by letting you select one of the inputs as a clock and use the other inputs as a qualifier.

This is useful when it is necessary to synchronize the display to a system clock and detect a system state. For example, consider a synchronous memory bus. The state trigger mode could be used if you want to see only events that occur when reading from a specific block of memory.

The equipment required for this exercise includes:

- HP 54111D oscilloscope
- HP 8116A function generator
- BNC tee
- two one-metre coaxial cables

### Initial Setup

Set up the instruments by:

- connecting the BNC tee to channel 1 of the HP 54111D;
- connecting one cable from the output of the function generator to the BNC tee on channel 1;
- connecting the other cable from channel 2 to the other side of the BNC tee.

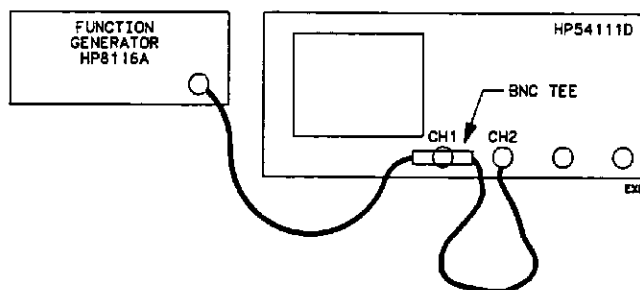

Figure 6-12. Equipment Connection.

The unequal cable lengths between the function generator and channel 1 and 2 provide a time differential between the signals displayed on the oscilloscope. The amount of propagation delay that is generated by a one metre cable is approximately 6 to 7 ns. The delay between channels is used to demonstrate the triggering capability of the HP 54111D.

- Instrument Setup** Set the function generator controls as follows:
- Function = Pulse
  - Frequency = 10 MHz
  - Width = 50 ns
  - Amplitude = 2 V
  - Offset = 0 V

If you are using an HP 8116A function generator, ensure that the "DISABLE" light is off.

After pressing the AUTO-SCALE key on the HP 54111D, set the controls as follows:

- Timebase menu
  - TIME/DIV = 5 ns/div
  - Sweep mode = Trg'd
- Display menu
  - Display = Single Screen
  - Graticule = Axes
- Chan 1 & 2 menus
  - Channel 1 & 2 offset = 0
  - Channel 1 & 2 coupling = dc
  - Channel 1 & 2 input impedance = 50  $\Omega$
  - Channel 1 & 2 VOLTS/DIV = 200 mV/div
- Trigger menu
  - TRIGGER LEVEL for chan 1 and 2 = 0
  - (set TRIGGER LEVEL in the edge trigger mode)
  - Trig Src = Chan 1

After the setup is completed the oscilloscope should be triggering on the positive edge of channel 1.

**Setting State Trigger** This exercise uses channel 2 as the edge source (clock) and channel 1 as the qualifier.

Select the Trigger menu:

- press Trigger mode key until State is selected
- set Trig On Pos/Neg Edge key to Pos
- set the Of key variable to Chan 2
  - selects channel 2 as the clock source
- set PATTERN = H-XX
  - indicates that channel 1 must be high (above the trigger level) before a signal edge on channel 2 can be used to generate a trigger.
  - Trig 3 and Trig 4 inputs are ignored as they are set to the “don't care” condition.

In this configuration the HP 54111D triggers on the first positive edge on channel 2 that occurs during a high on channel 1.

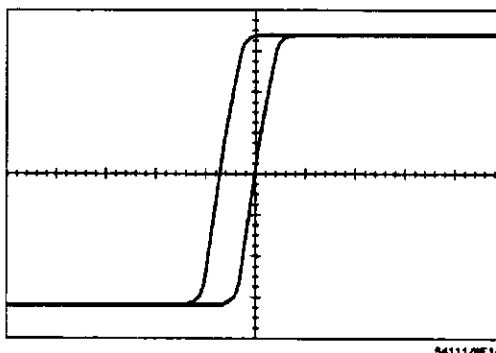

Figure 6-13. Pattern H-XX Waveform.

Notice that if you press the Is Present/Is Not Present key and change it to Is Not Present, the oscilloscope stops triggering (i.e., the signal on channel 1 is true when the positive-going edge on channel 2 occurs, therefore a trigger does not occur).

---

## Time Trigger

The Time menu allows you to:

- arm on a signal edge of any source, wait for a period of time, and then trigger on an edge from any of the four inputs.

- Pos/Neg Edge Key** Pressing the Pos/Neg Edge key:
- selects the polarity of the arming edge.
- On Key** Pressing the first On key:
- selects the source of the arming edge.
- DELAY...THEN Key** Pressing the DELAY .... THEN key:
- defines the period of time between the arming edge and the time the HP 54111D will accept a trigger—range is from 20 ns to 5 seconds (use entry devices).
- Trig On Pos/Neg Edge Key** Pressing the Trig On Pos/Neg Edge:
- selects the polarity of the trigger edge.
- On Key** Pressing the second On key:
- selects the source for the trigger edge.

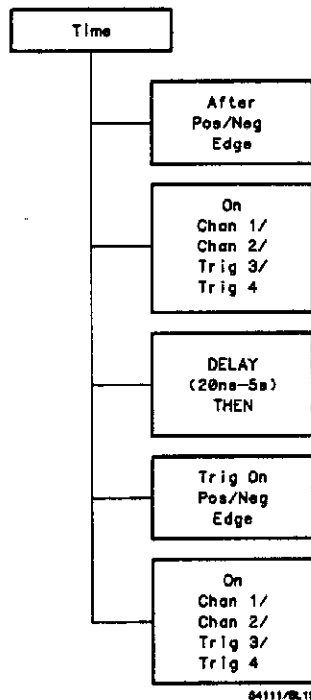

Figure 6-14. Time Menu.

## Time Delay Trigger Exercise

This exercise demonstrates how to use time to qualify a trigger event. Frequently in digital circuits there is a period of time when an output is invalid after a state change. This exercise shows how to set the oscilloscope so that it will ignore potential trigger events until after a defined period of time.

The equipment required for this exercise includes:

- HP 54111D oscilloscope
- HP 8116A function generator
- two one-metre coaxial cables

### Initial Setup

Set up the instruments by:

- connecting the BNC to channel 1 of the HP 54111D;
- connecting one cable from the output of the function generator to the BNC tee on channel 1;
- connecting the other cable from channel 2 to the other side of the BNC tee.

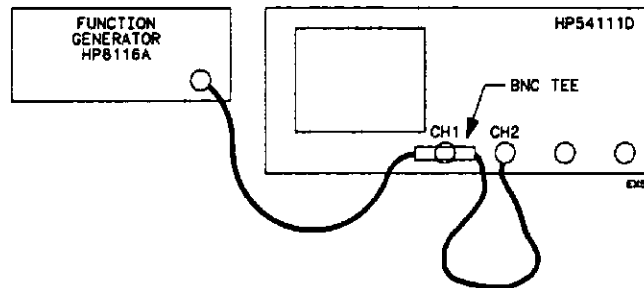

Figure 6-15. Equipment Connection.

The unequal cable lengths between the function generator and channel 1 and 2 provide a time differential between the signals displayed on the oscilloscope. The amount of propagation delay that is generated by one metre cable is approximately 6 to 7 ns. The delay between channels is used to demonstrate the triggering capability of the HP 54111D.

- Instrument Setup** Set the function generator controls as follows:
- Function = Pulse
  - Frequency = 10 MHz
  - Width = 50 ns
  - Amplitude = 2 V
  - Offset = 0 V

If you are using an HP 8116A function generator, ensure that the "DISABLE" light is off.

After pressing the AUTO-SCALE key on the HP 54111D, set the controls as follows:

- Timebase menu
  - TIME/DIV = 5 ns/div
  - Sweep mode = Trg'd
- Display menu
  - Display = Single Screen
  - Graticule = Axes
- Chan 1 & 2 menus
  - Channel 1 & 2 offset = 0
  - Channel 1 & 2 coupling = dc
  - Channel 1 & 2 input impedance = 50  $\Omega$
  - Channel 1 & 2 VOLTS/DIV= 200 mV/div
- Trigger menu
  - TRIGGER LEVEL for chan 1 and 2 = 0
  - (set TRIGGER LEVEL in edge trigger mode)
  - Trig Src = Chan 1

After the setup is complete the oscilloscope should be triggering on the positive edge of channel 1.

- Setting Time Trigger** Select the Trigger menu:
- press Trigger menu key until Time is selected
  - set After Pos/Neg key to Pos
  - set the first On key to Chan 1
  - set the DELAY ... THEN key to DELAY 1.000 s THEN
  - set the Trig On Neg/Pos Edge to Neg
  - set the second On key to Chan 2

In this configuration, the HP 54111D generates a trigger on the last of three sequential events:

- on channel 1, a positive-going signal must cross the trigger threshold;
- one second must elapse; and
- on channel 2, a negative-going signal must cross the trigger threshold.

Press the CLEAR DISPLAY key and notice that:

- the HP 54111D is triggering at one second intervals.

Change the delay time and notice:

- the time between trigger intervals changes proportionally with the delay time.

Changing the polarity of the Trig On Edge key from Neg to Pos causes:

- the HP 54111D to trigger on the positive edge of channel 2.

---

## Event Trigger

The Event Trigger mode allows you to:

- define an edge as a trigger qualifier—once this edge is detected, the HP 54111D will accept a trigger after a definable number of edges on any input.

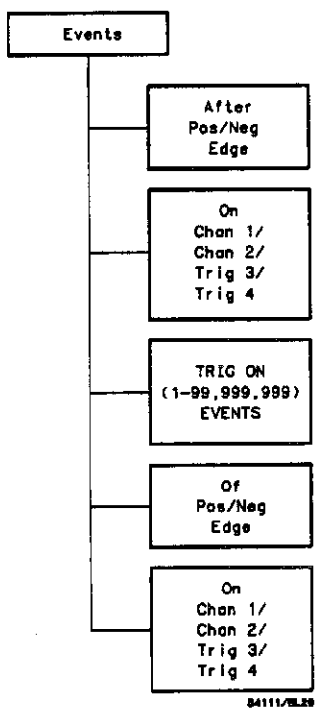

Figure 6-16. Event Menu.

**After Pos/Neg Edge Key** Pressing the After Pos/Neg Edge key:  
 • selects the polarity of the arming edge.

**On Key** Pressing the first On key:  
 • selects the source of the arming edge.



- TRIG ON N EVENTS Key** Pressing the TRIG ON N EVENTS key:
- defines the number of trigger events that must occur before the HP 54111D will trigger (after the qualifier)  
— range is from 1 to 99,999,999 (use entry devices).
- OF Pos/Neg Edge Key** Pressing the Of Pos/Neg Edge key:
- selects the polarity of the trigger edge.
- On Key** Pressing the second On key:
- selects the source of the trigger edge.

The polarity of the arming edge and the trigger edge are complementary if only a single channel is selected.

---

### **Event Delay Trigger Exercise**

This exercise demonstrates the ability of the HP 54111D to use events to delay the trigger.

One specific application for this trigger mode is to isolate a specific line of video information by delaying the trigger a specific number of horizontal sync pulses after you have initially qualified the event delay with the vertical sync.

The delay-by-events mode is particularly useful in systems where the data rate fluctuates or jitters, as in a disc drive. You could use the delay by events mode to arm on the index pulse in a disc drive, then trigger on a data pulse anywhere around the track. This stabilizes the display on a particular pulse.

The event trigger mode works much the same way as the time trigger mode, except that it allows you to delay the trigger using events rather than time.

The equipment required for this exercise includes:

- HP 54111D oscilloscope
- HP 8116A function generator
- two one-metre coax cables
- BNC tee

- Initial Setup** Set up the instruments by:
- connecting the BNC tee to channel 1 of the HP 54111D;
  - connecting one cable from the output of the function generator to the BNC tee on channel 1;
  - connecting the other cable from channel 2 to the other side of the BNC tee.

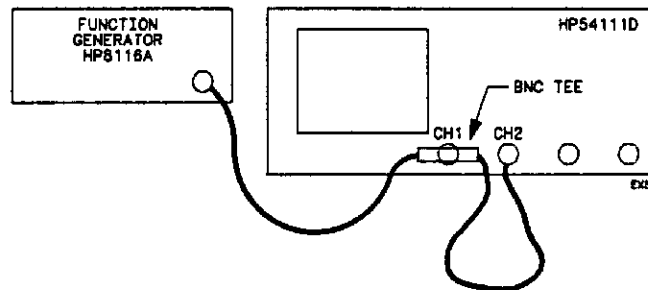

*Figure 6-17. Equipment Connection.*

The unequal cable lengths between the function generator and channel 1 and 2 provide a time differential between the signals displayed on the oscilloscope. The amount of propagation delay that is generated by a one metre cable is approximately 6 to 7 ns. The delay between channels is used to demonstrate the triggering capability of the HP 54111D.

- Setting Event Trigger** This exercise uses a positive edge on channel 2 to cause the oscilloscope to start counting a given number of edges from a second source (channel 1 in this exercise). The oscilloscope generates a trigger after the specified number of edges on the second source have been connected. Select the Trigger menu:
- press Trigger mode key until Event is selected
  - set the After Neg/Pos Edge key to Neg
  - set the first On key to Chan 2
    - selects Chan 2 as qualifier source
  - set the TRIG ON ... EVENTS key to TRIG ON 10,000,000 EVENTS
    - defines the number of events that are used to delay the trigger
  - set the Of Pos/Neg Edge key to Pos
    - selects the positive edge for the trigger source
  - set the second On key to On Chan 1
    - selects Chan 1 as the source for the delay events and the trigger

Press the CLEAR DISPLAY key and notice that the oscilloscope is triggering once a second. This is expected because the frequency of the function generator is set to 10 MHz.

Change the trigger-on-events number and notice the effect on the display. The trigger interval changes proportionally with the number of events.

# 7

## DISPLAY MENU

---

### Section Contents

- Description of the real-time (single-shot) and repetitive digitizing modes, plus an example illustrating the use of pre/post-trigger displays and the memory bar
  - Description of the 6/7/8-bit data filters in the real-time mode and the averaging capabilities in the repetitive mode
  - Discussion of the tradeoff between filtering and bandwidth; features are discussed that increase measurement accuracy and instrument usability
  - Exercises involving single-shot capture and zoom and pan
- 

### Overview

- The Display menu key allows you to:
- configure the HP 54111D for either single-shot or repetitive acquisition
  - vary resolution from 6 to 7 or 8 bits
  - define the waveform display area for single or multiple waveform displays
  - select a graticule

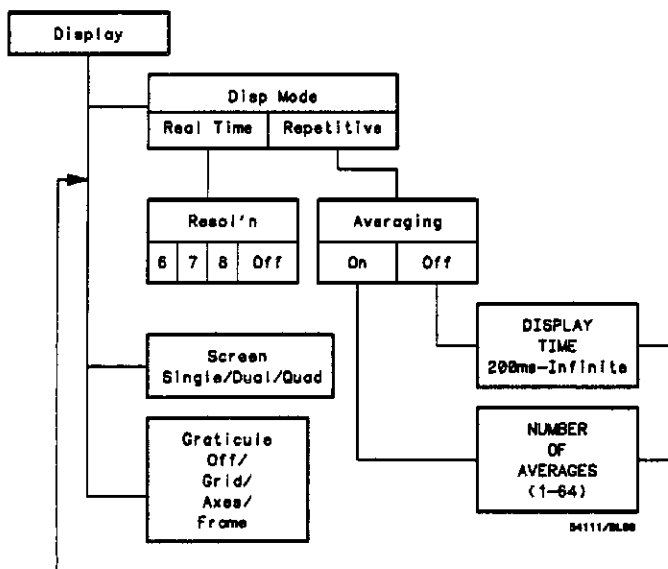

Figure 7-1. Display Menu.

## Display Mode Key

After you have pressed the Display menu key:

- the Displ Mode key is highlighted, allowing you to select:
  - Real Time
  - Repetitive

Depending on the display mode you select, the HP 54111D is configured for either single-shot or repetitive acquisition. Because of these different display modes, you have virtually two oscilloscopes in one instrument—one with up to 250 MHz bandwidth single-shot (1 gigasample/second digitizing rate) and the other with a 500 MHz repetitive bandwidth.

When in the repetitive mode, the HP 54111D uses a random repetitive sampling technique. For more information on how this works, please refer to *Feeling Comfortable With Digitizing Oscilloscopes*, Chapter 4.

If you select the real-time display mode:

- the HP 54111D displays data collected during successive single-shot acquisitions from either or both input channels.
  - because the 54111D can make a single-shot capture simultaneously on channels 1 and 2, you can capture two simultaneous non-recurring or very low repetition rate events.
- some or all of the 8k waveform buffer memories (each channel has its own 8k buffer) can be displayed. The displayed signal is completely updated as each new acquisition is made.
- the following graphics are displayed at the top of the waveform display areas:
  - memory bar - represents the displayed portion of the waveform record
  - memory bar display line - represents the entire 8k waveform record
  - "T" - indicates the trigger point's location with respect to the displayed signals

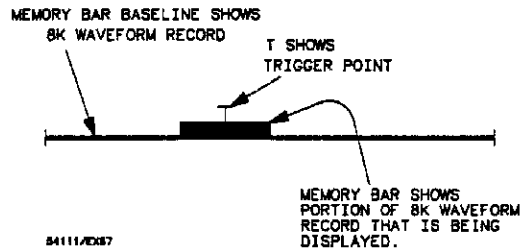

Figure 7-2. Memory Bar.

---

### Memory Bar Exercise

This exercise demonstrates the memory bar as well as the HP 54111D's ability to display signals that occur before and after the trigger event. The memory bar is very helpful when it is important to know what portion of the waveform record is being displayed.

For this exercise:

- use a 5 MHz square wave connected to channel 1, and set the sweep speed to 50 ns/div.
- Set the Display mode to Real Time and notice that the memory bar is displayed.

After the signal is displayed:

- select the delay function of the Timebase menu and use the entry devices to vary the delay.
  - while running (STOP/SINGLE key not pressed), varying DELAY will vary the acquisition record with respect to the trigger point.

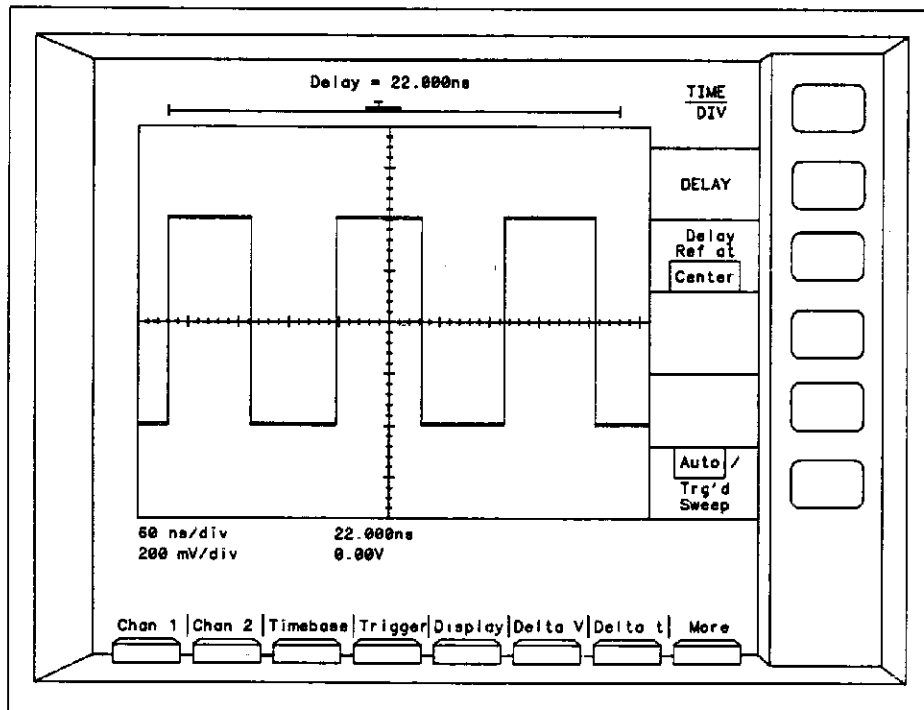

Figure 7.3 Memory Bar Using Delay.

You can view three different portions of the waveform record while running (i.e., acquiring data). These are:

- left
- right
- center

These are selected with the Delay Ref key (Timebase menu). While acquisition is stopped, you can position the display window anywhere on the waveform record by changing the DELAY value

#### Note

*With the memory bar and the "T" to the right, all data acquired occurs before the trigger. In this situation, you cannot input any negative value.*

Now, move the memory bar and "T" to the left or center screen if you had it on the right (see Note above). Delay time moves the 8k acquisition window relative to the trigger point. Notice that as you change the delay, the "T" moves to the right or left of the memory bar depending on whether you use a negative or positive delay. Negative delay allows you to view pre-trigger events, and positive delay allows you to view post-trigger events.

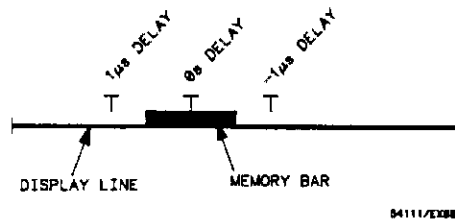

Figure 7-4 Memory Bar With  $\pm 1 \mu s$  Delay.



Now, set DELAY to 1  $\mu$ s:

- the "T" moves to the left of (before) the memory bar indicating that you are viewing the portion of the input signal that occurred 1  $\mu$ s after the trigger event.

If you set the delay to -1  $\mu$ s:

- the trigger moves to the right of (after) the memory bar indicating that you are viewing the signal 1  $\mu$ s before the trigger event.

---

## Resolution Key

Disp Mode Real Time
Resol'n Off
Screen Dual
Graticule Grid

Pressing the Resol'n (resolution) key:

- allows you to select 6, 7, or 8-bit digital filters to increase the resolution of the displayed signal and achieve a more faithful reproduction of the input signal.
- lets you turn off the filter, allowing you to view raw data.

Increasing the resolution by selecting the 7 or 8-bit filter reduces the bandwidth. The bandwidth limitations are:

- 6 bits - up to 250 MHz
- 7 bits - up to 100 MHz
- 8 bits - up to 25 MHz

If you reduce the sweep speed to below 50 ns/div:

- the bandwidth limit of each of these filters is reduced linearly with the sample rate (see Chapter 5, page 5-1).

For example, the maximum bandwidth using the 8-bit filter at 50 ns/div sweep speed is 25 MHz. If you change the sweep speed to 500 ns/div, the bandwidth using the 8-bit filter is limited to 2.5 MHz.

### Note

*These digital filters work very much like analog bandwidth-limit filters. In the real-time display mode, these filters as well as the sweep speed affect bandwidth. If you need a high bandwidth at a low sweep speed, consider using the Repetitive display mode with Averaging ON.*

If you select the Repetitive display mode:

- the HP 54111D displays data collected from multiple acquisitions from either or both of the input channels.
- data from multiple acquisitions can be averaged to generate a display—the Averaging key appears when Repetitive is selected.
- data from each acquisition can be displayed:
  - for a definable period of time (persistence = 200 ms to 10.9 seconds).
  - indefinitely (persistence = infinite at values of 11 seconds and greater).
- establishes waveform records at 501 data points.
- makes waveform memories 5-8 available (see Chapter 10, for more details).

FOR MORE DETAILS...on the 6, 7, 8-bit filters, please refer to Appendix A, "Improving Resolution."

---

## Averaging Key

The Averaging key allows you to:

- turn the Averaging mode On or Off

If Averaging is On:

- NUMBER OF AVERAGES key is activated and controlled by the entry devices.
- data from multiple acquisitions is averaged to generate the displayed waveform(s).

In the averaging mode, the last acquired data points are averaged with previously acquired data before they are displayed.

When you select the NUMBER OF AVERAGES key:

- you can specify the number of averages you want from 1 to 64 by using the entry devices.

Displayed noise can be significantly reduced using the averaging mode. As the number of averages is increased from 1 to 64, the display becomes less responsive to changes to the input signal(s); however, using more averages reduces noise and improves resolution.

**Persistence** If Averaging is Off:

- DISPLAY TIME key is activated and controlled by the entry devices.
- data is maintained on the display for a defined period of time or indefinitely.
  - minimum display time (persistence) is 200 ms.
  - any display time equal to or greater than 11 seconds defaults to “Infinite.”
- persistence time is listed at the top of the display.

In the infinite persistence mode:

- data points remain on the display until:
  - CLEAR DISPLAY key is pressed, or
  - any other major setup parameter is changed.

If variable persistence (persistence other than infinite) is selected:

- the display changes as the input signal changes.
- the signal is stored indefinitely on the display if the trigger is lost and the unit is in Trg'd Sweep.

A minimum persistence setting is useful when the input signal is changing and you need immediate feedback, such as rapidly probing from point to point, or setting the amplitude or frequency of a signal source. More persistence is useful when observing long-term changes in the signal or low signal repetition rates. Infinite persistence is useful for worst-case characterizations of signal noise, jitter, drift, timing, etc.

---

**Screen Key**

The Screen key allows you to:

- define the waveform display area as:
  - Single (1 area)
    - all input signals, displayed memories, and displayed functions\*\* are superimposed in the waveform display area.
  - Dual (2 separate areas)
    - channel/function 1 is displayed in the top half of the display and channel/function 2 is displayed in the bottom half. Any of the waveform memories may be independently displayed in either half of the display.

\*\* “Functions” refers to the functions you can set up in the Wfm (Waveform) Math menu, see Chapter 11.

- Quad (4 separate areas)
- signals from channel 1, channel 2, function 1, and function 2 are displayed from top to bottom, respectively. Any of the waveform memories may be independently displayed in any one of the four display areas.

Vertical scaling is changed automatically to provide an appropriate display as the screen function is changed.

---

### Graticule Key

Pressing the Graticule key allows you to:

- change or erase the display graticule.

The three graticules available are:

- Grid
- Axes
- Frame

---

### Single Shot Exercise

This exercise demonstrates how to take advantage of the HP 54111D's single-shot capture capability using:

- the Repetitive display mode
  - how to build a waveform using the STOP/SINGLE key
  - see the 1 gigasample/second digitizing rate
- the Real Time display mode
  - compare interpolated with non-interpolated data

With the HP 54111D's 1 gigasample/second digitizing rate, you can capture very fast non-recurring events, such as a microprocessor start-up sequence. This allows the capture of error-causing glitches that disrupt system performance.

The equipment required for this exercise includes:

- HP 54111D oscilloscope
- HP 8116A function generator
- one metre coaxial cable

You may use another function generator if it is capable of providing:

- 500 kHz
- 2 V
- 10 ns pulse

**Initial/Instrument Setup** Connect the output of the HP 8116A to the channel 1 input of the HP 54111D.

Set up the HP 8116A as follows:

- Normal mode
- Frequency = 500 kHz
- pulse width = 10 ns
- Amplitude = 2 V
- Offset = 0
- Function = pulse
- Make sure the disable light is turned off

After pressing AUTO-SCALE, set up the HP 54111D as follows:

- Chan 1 menu:
  - VOLTS/DIV = 500 mV/div
  - Input Coupling = dc
  - Input Impedance = 50  $\Omega$
- Timebase menu:
  - TIME/DIV = 2 ns
- Display menu:
  - Display mode = Repetitive

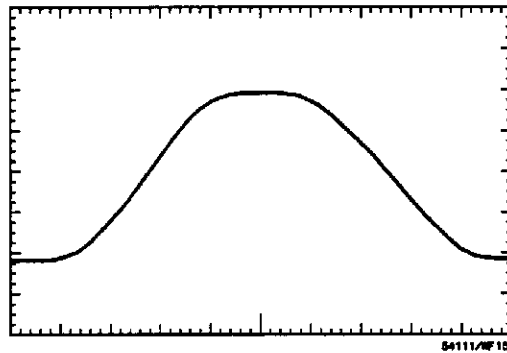

*Figure 7-5. Single Acquisition Initial Waveform.*

### Single-shot with Repetitive Display mode

Using the System Control keys:

- press the STOP/SINGLE key to stop new data from being displayed
- press CLEAR DISPLAY key
- press the STOP/SINGLE and CLEAR DISPLAY keys alternately—this displays, and then erases single-shot data.
- press the STOP/SINGLE key repeatedly and notice that the waveform fills in.

If Averaging is Off:

- data points on the display are not changed by new data when the STOP/SINGLE key is pressed.
- data stays on screen until the instrument setup is modified or the CLEAR DISPLAY key is pressed.

If Averaging is On:

- data on screen is averaged with new data when the STOP/SINGLE key is pressed, assuming enough data points have been acquired to satisfy the NUMBER OF AVERAGES.

To see the 1 gigasample/second digitizing rate, press:

- CLEAR DISPLAY key
- STOP/SINGLE key

The display shows a series of data points 1 ns apart. This 1-ns separation is defined by the 1 gigasample/second digitizing rate.

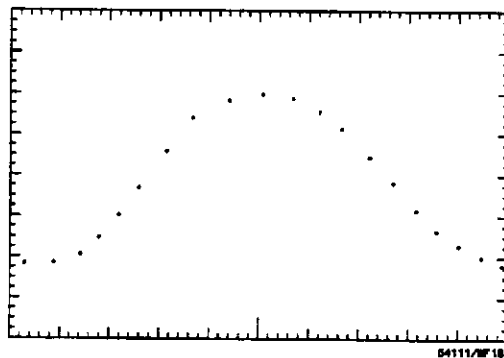

Figure 7-6. Single Acquisition Repetitive Display Mode.

To see the limitations of single-shot capture in the repetitive display mode:

- select the Timebase menu and set TIME/DIV = 500 ps
- press CLEAR DISPLAY key
- press STOP/SINGLE key

Five data points from the input signal are displayed.

To acquire a more useful display using the single-shot mode at faster TIME/DIV settings:

- select the Real Time display mode (Display menu)
- set Resol'n = 6 bits
- press CLEAR DISPLAY key
- press STOP/SINGLE key

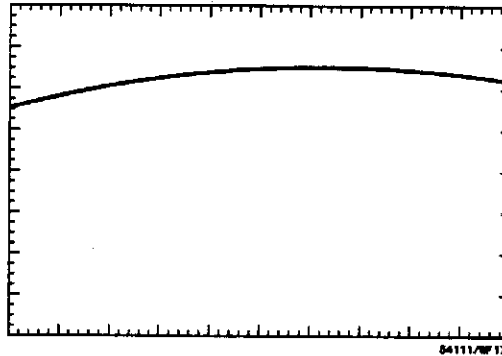

*Figure 7-7. Single Acquisition Real Time Display Mode.*

In the real time display mode, the HP 54111D uses a digital reconstruction filter to provide a more continuous waveform display.

It automatically operates:

- when there are less than 501 points on screen (i.e., TIME/DIV settings faster than 50 ns/div).

---

## Zoom and Pan Exercise

This exercise demonstrates:

- how the TIME/DIV function can be used to zoom (i.e., horizontally expand, magnify, or compress a single-shot waveform) in the real time display mode.
- how the DELAY function can be used to pan (i.e., horizontally move a single-shot waveform) in the real time display mode.

### Note

*You can only use the zoom and pan features when the HP 54111D is in the real time mode and acquisition is stopped.*

Zooming either expands or compresses the waveform on the horizontal axis and is changed by adjusting TIME/DIV. Decreasing TIME/DIV expands the waveform, and increasing TIME/DIV compresses the waveform.

Panning moves the waveform on the horizontal axis and is changed by adjusting DELAY time. Increasing DELAY moves the waveform to the left, and decreasing DELAY moves the waveform to the right.

Applications that require precise evaluation of low rep rate signals, such as radar and transponder pulse trains, are simplified by zooming and panning on single-shot data.

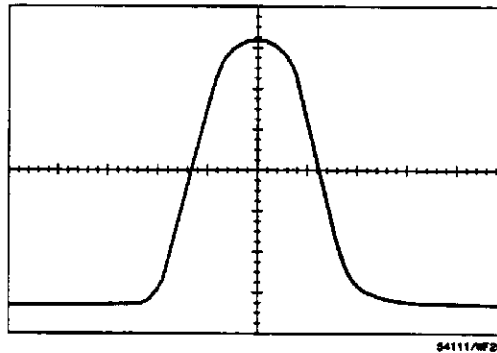

Figure 7-8. A Given Waveform.



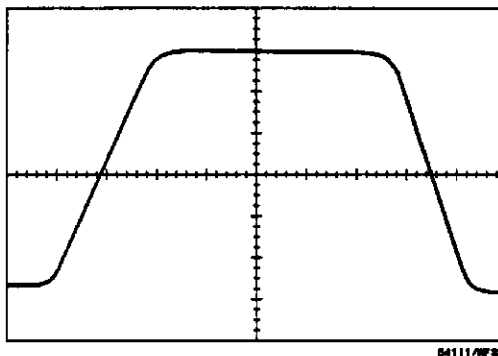

Figure 7-9. Zooming a Waveform.

The equipment required for this exercise includes:

- HP 54111D oscilloscope
- HP 8116A function generator
- one metre coaxial cable

**Initial/Instrument Setup**

Connect the output of the HP 8116A to the channel 1 input of the HP 54111D.

Set up the HP 8116A as follows:

- Normal mode
- Frequency = 500 kHz
- Pulse width = 10 ns
- Amplitude = 2 V
- Offset = 0
- Function = pulse
- Make sure the disable light is turned out

After pressing AUTO-SCALE, set up the HP 54111D as follows:

- Chan 1 menu:
  - VOLTS/DIV = 400 mV
  - Input Coupling = dc
  - Input Impedance = 50  $\Omega$
- Timebase menu:
  - TIME/DIV = 5 ns
- Display menu:
  - Display mode = Real Time
  - Resol'n = 6 bits

**Using The  
Zoom Feature**

To acquire a single-shot waveform record:

- press the STOP/SINGLE key
- press the CLEAR DISPLAY key
- press the STOP/SINGLE key again—this causes the HP 54111D to make a single acquisition.

After the 8k single shot waveform record is acquired:

- select the Timebase menu and select TIME/DIV

Varying TIME/DIV allows you to view either a larger or smaller portion of the 8k waveform record. This allows you to display the whole waveform record by increasing TIME/DIV or to zoom in on a segment of the record by decreasing TIME/DIV. The memory bar expands or contracts as the portion of the record being displayed is increased or decreased.

To demonstrate zooming out:

- set TIME/DIV = 1  $\mu$ s/div

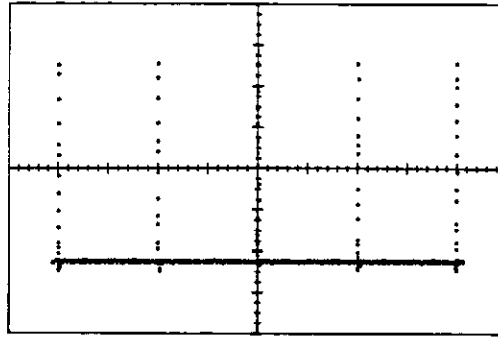

Figure 7-10 Zooming Out.

Changing the TIME/DIV to 1  $\mu$ s/div compresses the waveform to approximately eight horizontal divisions and allows five of the 500 kHz pulses to be displayed. The memory bar indicates that the entire waveform record is being displayed.

In this example, we acquired 8192 data points at a 1 gigasample/second digitizing rate. Using the 2 ns/div TIME/DIV setting (2 samples/div) provides 409.6 screen diameters of data. On the HP 54111D ten divisions = one screen diameter. As TIME/DIV is increased, the number of screen diameters is reduced linearly (i.e., more and more 1 ns samples are needed to define the longer periods

of time that are represented on the display). At the TIME/DIV setting of 1  $\mu\text{s}/\text{div}$ , the 8192 1 ns samples represent 8.192 divisions (i.e., 8.192  $\mu\text{s}$ ).

The displayed portion of the 8k waveform record is mapped into the 501 horizontal data points of the HP 54111D's display. If the 8k waveform record represents less than  $10 \times \text{TIME}/\text{DIV}$  (i.e., less than full screen), the waveform record will be mapped into proportionally fewer display data points. In this example,  $0.8192 \times 501$  (410) display data points are used when TIME/DIV is set to 1  $\mu\text{s}/\text{div}$ .

Increasing TIME/DIV on a single-shot waveform record or a waveform memory is referred to as "zooming out." Conversely, decreasing TIME/DIV on these waveforms is referred to as "zooming in."

- Zooming In** To demonstrate zooming in:
- set TIME/DIV = 500 ps/div

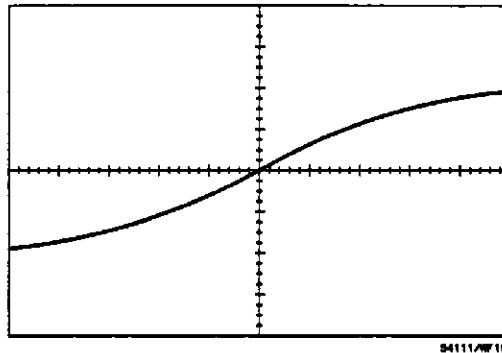

Figure 7-11. Zooming In.

As TIME/DIV is decreased the amount of time represented on the display is reduced. This expands the signal.

With TIME/DIV set at 500 ps/div, the samples are two horizontal divisions apart (i.e., 1 gigasample/second digitizing rate). The HP 54111D uses a digital reconstruction filter to fill in the waveform to provide a more usable display.

**Panning** Varying DELAY time allows you to view various segments of the waveform record. To demonstrate panning:

- set TIME/DIV = 5 ns/div
- set DELAY = 25 ns

The screen now provides a detailed look at the waveform after the pulse. The delay time indicates that you are viewing the waveform 25 ns after the trigger point.

As DELAY is increased, the waveform moves to the left because you are looking farther and farther past the trigger point.

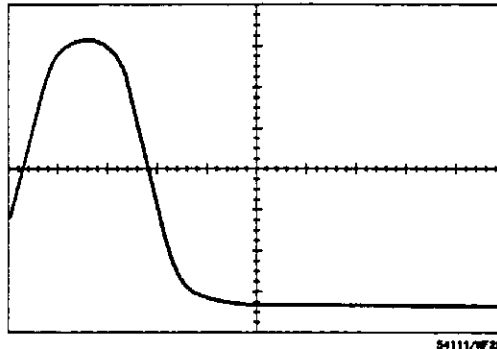

*Figure 7-12. Panning Right.*

If DELAY is increased in the negative time direction (i.e., decreased), the waveform moves to the right because you are viewing the signal before the trigger point.

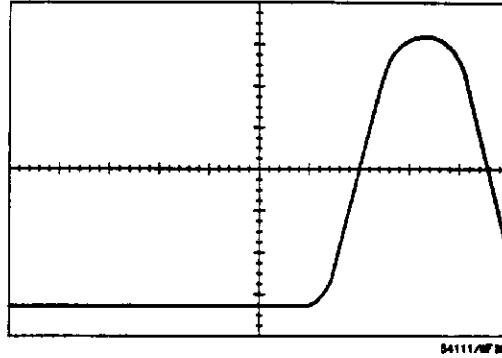

*Figure 7-13. Panning Left*

This feature allows you to look at a large time window in detail. This is similar to using a magnifying glass to view a page of small print.

# 8

## DELTA V MENU

---

### Section Contents

- Description of the voltage markers and automatic preset levels
  - Exercise illustrates how to make a source-to-source voltage measurement
- 

### Overview

V Markers Off
MARKER 1 POSITION Chan 1
MARKER 2 POSITION Chan 1
Preset Levels 0-100%
Auto Level Set

The Delta V menu allows you to:

- control two calibrated horizontal cursors that can be used:
  - to make absolute voltage measurements;
  - to make relative voltage measurements;
  - as reference markers when adjusting a signal to a given amplitude;
  - to define voltage levels for Delta T measurements.

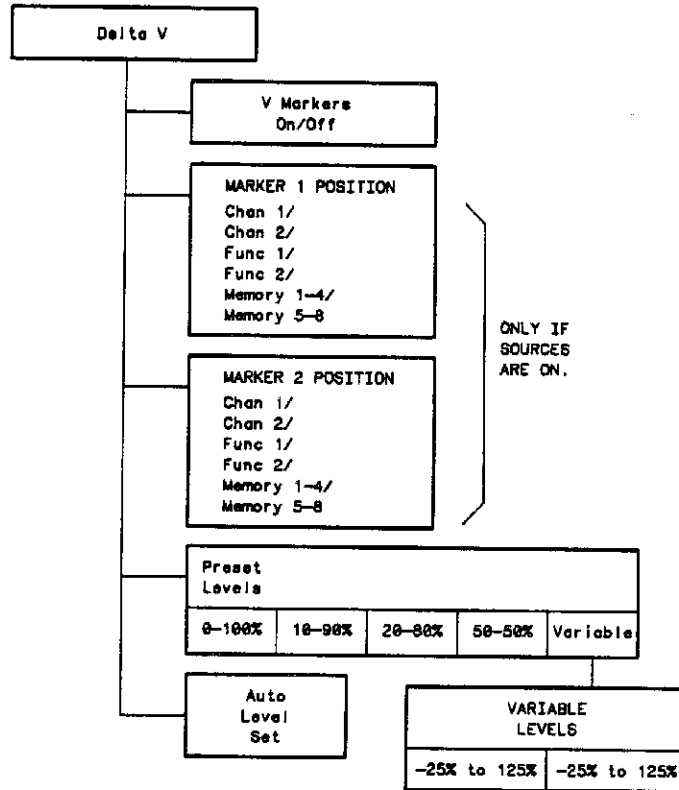

Figure 8-1. Delta V Menu.

## V Markers

After you have selected the Delta V menu and turned on the V markers:

- you can select and position the source for either of the V Markers.
  - the V Markers can be referenced to any source if the display for that source is on (excluding pixel memories\*\*).
  - the voltage shown at the top of the waveform display area indicates the voltage level of the selected V marker.

\*\* Please refer to Chapter 10, "WAVEFORM SAVE," for more details on the HP 54111D memories.

V Markers On
MARKER 1 POSITION Chan 1
MARKER 2 POSITION Chan 1
Preset Levels Variable
VARIABLE LEVELS 125% - 16%
Auto Level Set

The V Marker sources are:

- channels 1 2
- functions 1 and 2 (set up in Wfm (waveform) Math menu)
- waveform memories 1 through 4 \*\*
  - available as marker sources only in the real-time mode (set up in the Display menu)
- waveform memories 5 through 8 \*\*
  - available as marker sources only in the repetitive mode (set up in the Display menu)

For a source to be available, its display must be turned on.

After assigning the markers to the desired source, the MARKER 1 POSITION and MARKER 2 POSITION function keys:

- allow you to position the markers vertically using the entry devices.

Marker 1 has long dashes, and marker 2 has short dashes.

If you are using the default colors, the V marker you have selected and its label are orange. If one of the marker position keys is the selected function, the values for  $\Delta V$  and the voltage level of the selected marker are also orange. The MARKER POSITION key that is not selected and its associated marker are displayed in gray. Values for  $\Delta V$  (the difference between the two markers) and the voltage level for each marker are displayed at the bottom of the screen.

### Preset Levels Key

When you press the fourth key down on the function menu (labeled 0-100% / 10-90% / 20-80% / 50-50% / Variable):

- the HP 54111D automatically positions the V markers on the display based on the current position of the markers.

\*\* Please refer to Chapter 10, "Waveform Save," for more details on the HP 54111D memories.



Selecting Variable:

- adds the VARIABLE LEVELS key to the menu:
  - provides two variables that are used to define the levels of the V markers the same way the fixed preset levels did.
  - the variable preset levels can be changed by using any of the entry devices. Range of each marker is .25% to 125%.

Auto Level Set key:

- first, performs a histogram on the displayed data to find the 0% and 100% levels, then
- automatically sets the V markers to the selected preset levels of the displayed signal(s).

---

**Preset Key and  
Source-to-Source  
Voltage  
Measurement**

This exercise demonstrates how to use the Preset key to position the V Markers.

The equipment required for this exercise includes:

- HP 54111D oscilloscope
- two HP 10033A probes

**Initial/Instrument  
Setup**

Set up your HP 54111D as follows:

- install the HP 10033A probes on Channel 1 and Channel 2
- attach the probe tips to the front-panel cal signal on the HP 54111D
- press AUTO-SCALE

Select the Delta V menu:

- turn V Markers On
- set Preset Levels = 0 – 100%
- press Auto Level Set key

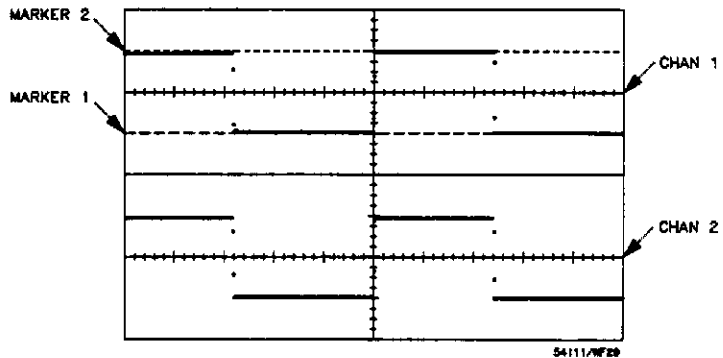

Figure 8-2. V Markers.

To see how the Preset Levels key works, press the key several times and notice how the markers move to the defined levels.

**Source-to-Source  
Voltage  
Measurement**

Assigning the V markers to different sources allows you to make voltage measurements between those sources.

Perform the following:

- set MARKER 2 POSITION = Chan 2
- use the entry devices and:
  - position marker 1 at the top of the channel 1 waveform
  - position marker 2 at the bottom of the channel 2 waveform

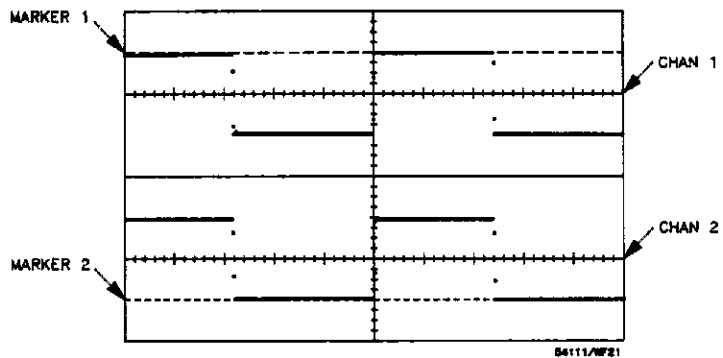

Figure 8-3. Source-to-source V Markers.

Marker 1 is at the top of channel 1 (top display) and marker 2 is at the bottom of channel 2 (bottom display).

The difference between the two voltage markers is listed at the bottom of the display labeled  $\Delta V$ .

This technique can be used with any of the sources to make source-to-source voltage measurements.

# 9

## DELTA T MENU

---

### Section Contents

- Description of the stop and start markers
  - Exercise illustrates how to make a time interval measurement
- 

### Overview

T Markers <input checked="" type="checkbox"/>
START MARKER
STOP MARKER
START ON <input checked="" type="checkbox"/> POS EDGE 1
STOP ON <input checked="" type="checkbox"/> POS EDGE 1
Edge Find

The Delta t function menu:

- controls two calibrated time markers that can be used to make measurements in the time domain.
  - these markers can be positioned using signal edges or time reference.
- enables making time interval measurements based on the voltage levels set in the Delta V menu (e.g., 20% to 80% risetime measurements)

The values of the two markers with respect to the trigger point and to each other (i.e., delta time) are displayed at the bottom of the CRT.

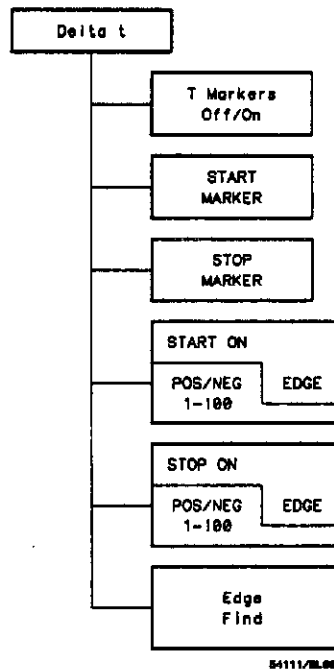

Figure 9-1. Delta t Menu.

---

### Start/Stop Markers

After you have selected the Delta t menu and turned on the t markers:

- you can move each t marker manually by selecting START MARKER or STOP MARKER and using the entry devices.
  - if default colors are used, the selected t marker is displayed in orange.

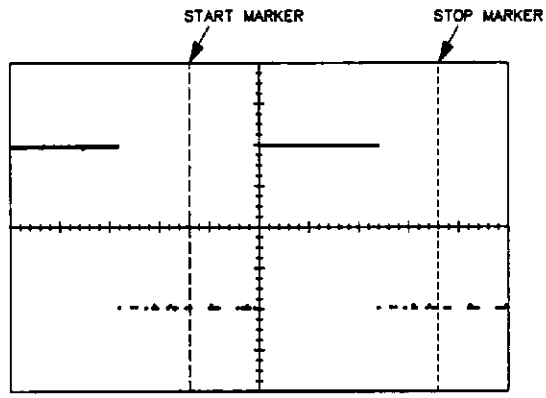

Figure 9-2. Start/Stop Markers.

### Start/Stop On Edge

The Start/Stop On Edge keys allow you to:

- move the t markers to any on-screen signal edge based on the voltage marker values set in the Delta V menu.

After you have selected one of the edge keys:

- you may select the number of the edge of interest using any one of the entry devices.

If an edge key has been selected and is pressed a second time:

- the polarity of the edge changes.

The V Marker levels define the intersections of the on-screen signal edges as follows:

- the start-on-edge marker is associated with V Marker 1, and the stop-on-edge marker is associated with V Marker 2
- the associated V Marker must intersect the signal for the start/stop-on-edge markers to find the defined edge(s).

#### Note

*If the advisory message, "Edges required for measurement not found" appears, return to the Delta V menu and adjust the V Markers to intersect the signal of interest.*

---

## Edge Find Key

The Edge Find key moves the t markers to the waveform edges defined by the start/stop-on-edge keys.

Hint: use this key if you have moved the t markers (using the START/STOP MARKER keys) and you want to return to the edges defined by the edge keys.

---

## Time-interval Measurement Exercise

This exercise demonstrates many of the functions available through the Delta t menu.

The equipment required for this exercise includes:

- HP 54111D oscilloscope
- HP 10033A probe

### Initial/Instrument Setup

Set up your HP 54111D system as follows:

- connect the front-panel cal signal to channel 1 using an HP 10033A probe.
- press AUTO-SCALE.

Select the Timebase menu:

- set the TIME/DIV to  $500 \mu\text{s}/\text{div}$ —this should display about ten pulses on the display.

Select the Delta t menu:

- turn the t markers On.
- use the entry devices and move the START MARKER to the first negative edge of the cal signal.
- move the STOP MARKER to the second negative edge.

You have just measured the period of a pulse.

At the bottom of the CRT, the value of the start marker indicates that it is approximately  $500 \mu\text{s}$  before the stop marker, and approximately  $2.3 \text{ ms}$  before ( $-2.3 \text{ ms}$ ) the trigger event (delay = 0), which was established at center screen when you pressed AUTO-SCALE. The time interval between the t markers ( $\Delta t$ ) is approximately  $500 \mu\text{s}$ . This is the pulse width.

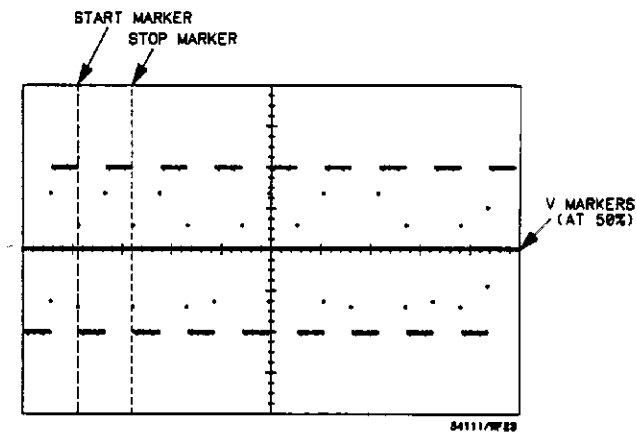

Figure 9-3. Time-interval Measurement.

To continue the exercise:

- select the Delta V menu and turn the V Markers on.
- press the Preset Levels key until 50-50% is selected.
- press the Auto Level Set key
  - this moves the V Markers to the selected Preset Levels.
- return to the Delta t menu and press the STOP ON POS/NEG EDGE key several times
  - notice that the POS/NEG indicator alternates, and the stop marker alternates from the positive edge to the negative edge of the pulse.
- try using each of the entry devices to move the start edge to another pulse. The stop edge can be changed using the same technique.
  - if you attempt to move one of the t markers to an edge that is not displayed on the CRT, the error message “Edges required for measurement not found” is displayed for 5 seconds.
- set the start marker to the first (1) positive edge and set the stop marker to the fifth (5) positive edge
  - the time interval between the two t markers is listed at the bottom of the display ( $\Delta t$ ).

This technique can be used to measure burst duration or to measure the time over a number of signal repetitions.



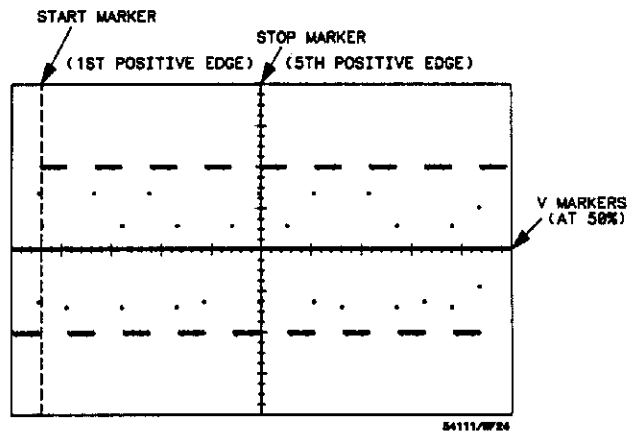

Figure 9-4. Start and Stop on Edges.

# 10

## WAVEFORM SAVE MENU

---

### Section Contents

- Description of how to store and view waveforms in the real-time, repetitive, and pixel memories
- 

### Overview

The WfmSave menu allows you to:

- access the 10 memories that are available from the HP 54111D's front panel.
  - eight are waveform memories, designated as waveform memories 1 through 8
    - waveform memories 1-4 are 8k data points long
    - waveform memories 5-8 are 501 data points long
  - two are pixel memories
    - designated as pixel memories 9 and 10

All memories (waveform and pixel) are volatile (i.e., the data in these memories is lost when the instrument is turned off).

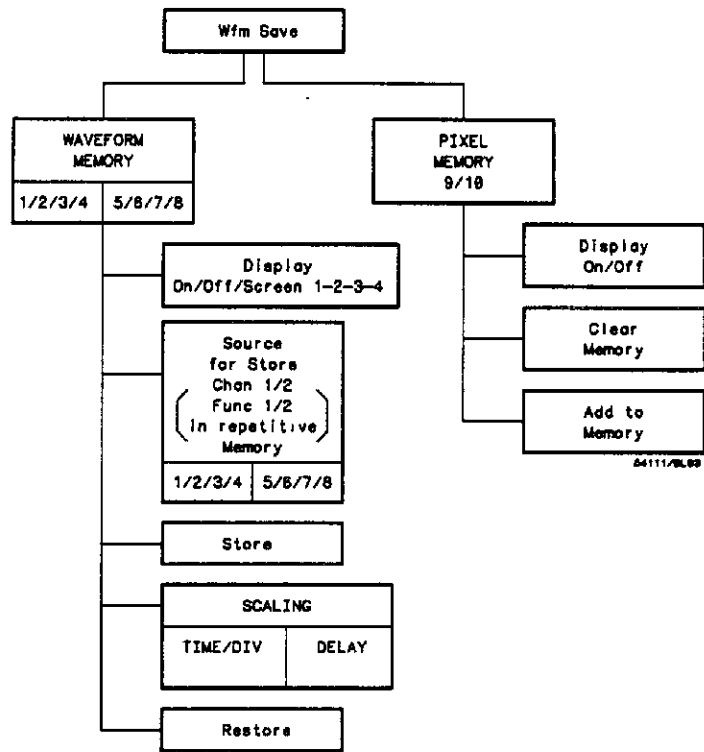

Figure 10-1. Waveform Menu.

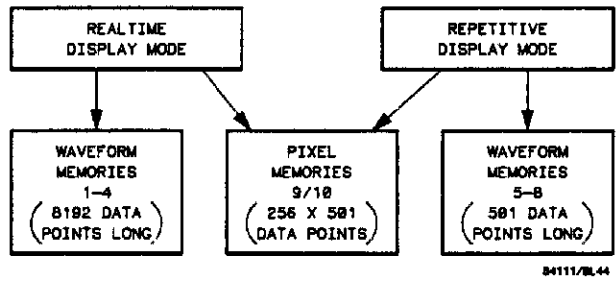

Figure 10-2. Memory Type Vs. Display Mode.

Waveform Save Menu  
10-2

---

## Memory Selection

After you have selected the Wfm (waveform) Save menu:

- the WAVEFORM/PIXEL MEMORY key (the top function key) is highlighted, allowing you to use any one of the entry devices to choose from the following selections depending on the display mode you are in.

In the real-time display mode (set up in the Display menu):

- you can select Memory 1-4
  - these waveform memories are 8k (8192) data points long

In the repetitive display mode (set up in the Display menu):

- you can select Memory 5-8
  - these waveform memories are 501 data points long

---

## Pixel Memories

Pixel memories are primarily used in situations where it is necessary to compare multiple signal acquisitions.

Pixel memories 9-10 are:

- available in both display modes
- 256 x 501 bit memories
- constructed so that multiple waveforms can be stored in each.

If more than one waveform is stored in a pixel memory:

- the waveforms are superimposed.

When you select Pixel Memory 9-10:

- the second key is the Display key
  - allows you to turn the pixel memory on or off.
- the third key in the menu changes to the Clear Memory key
  - allows you to erase whatever is stored in the selected pixel memory.
- the fourth key becomes the Add to Memory key
  - when pressed, all displayed channels and functions are stored to the selected pixel memory—joining whatever data is already stored there.

### Note

*You cannot make automatic measurements (from Measure menu) on waveforms stored in a pixel memory because waveform factors are not maintained.*

---

## Waveform Memories

When waveforms are stored in one of the eight waveform memories, the following waveform factors are stored as part of the record:

- vertical sensitivity
- vertical offset
- sweep speed
- time delay

This allows you to make automatic measurements on waveforms stored in these memories.

### Note

*Waveform memories can store only one waveform at a time. If you store a waveform to a memory that already contains a waveform record, the first record is written over and lost.*

**Display Key** The Display key:

- allows you to display or not display the selected memory.
- in the dual or quad screen mode, it allows you to select in which portion of the screen the memory is to be displayed (see Chapter 7, "Display Menu").

**Source For Store Key** The Source For Store key allows you to select which source is to be stored in the specified WAVEFORM MEMORY.

If the source is:

- a channel or a function, you must turn on that source.
- a memory, then that memory must have something stored in it.

When you are in the real-time display mode (memories 1-4):

- the third key is the Source For Store key
  - your choices for sources are:
    - Chan 1 & 2
    - Memory 1-4
- the fourth key is the Store key
  - when pressed, the selected source is stored.
- the fifth key becomes the SCALING key, it allows you:
  - to change the TIME/DIV on the selected memory (allows zooming).
  - to DELAY the selected memory (allows panning).
- the sixth key becomes the Restore key, it allows you:
  - to restore the selected memory to its original TIME/DIV and DELAY values.

Use the Restore key if you have been using the scaling functions and you want to restore the memory to its original condition.

When you are in the repetitive display mode (memories 5-8):

- the third key is the Source For Store key
  - your choices for sources are:
    - Chan 1 & 2
    - Memory 5-8
    - Function 1 & 2
- The fourth key is the Store key
  - when pressed, the selected source is stored.

# 11

## Waveform Math Menu

---

### Section Contents

This chapter will give you a brief description of the waveform math operations and a Waveform Math menu map. A waveform math exercise is also included at the end of this chapter.

---

### The Menu

The Waveform Math Menu includes the following mathematical operations:

- Versus
- Only
- Plus ( + )
- Subtract ( - )
- Invert
- Minimum
- Maximum
- Multiply ( \* )
- Integrate

Provisions for amplitude and offset scaling for all but Versus, Minimum and Maximum math functions are also included in this menu.

---

### Operation

To perform a waveform math operation, enter the Waveform Math Menu and select one of the Functions. A Function is defined by first choosing the mathematical function and then the two operands (see Waveform Math Map, Figure 11-1).

An operand may be channel one or two, or memory one through eight. Remember that memories one through four may only be accessed in the Real Time mode and memories five through eight can be accessed only in the Repetitive mode. Pixel memories (memories 9 and 10) may not be used as operands.

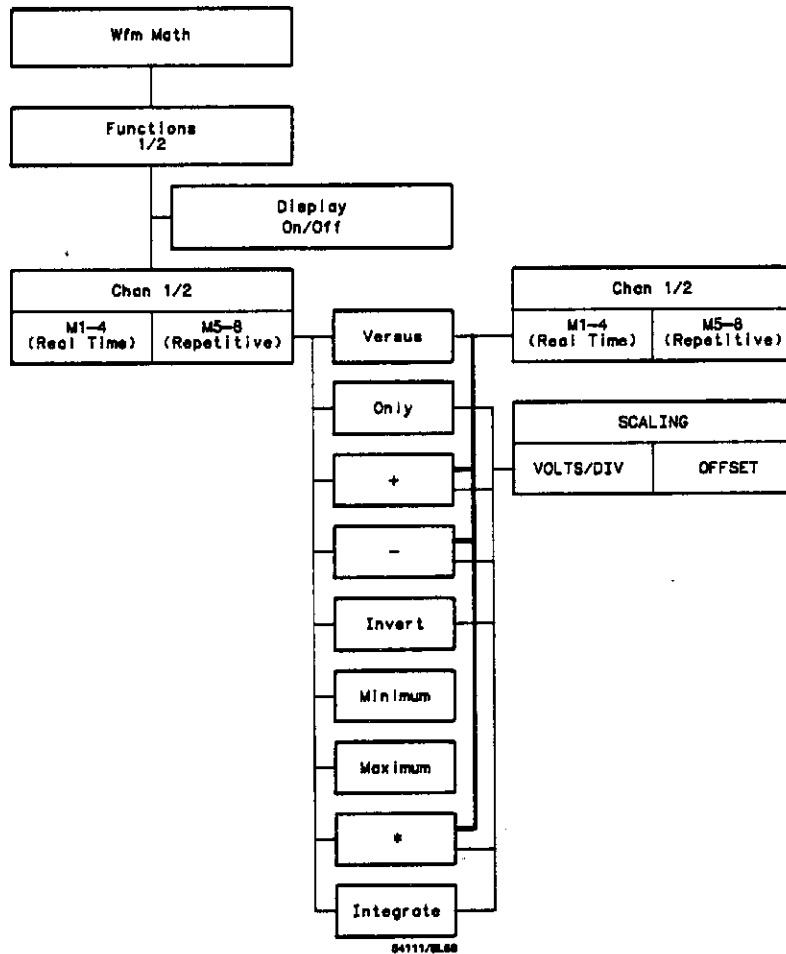
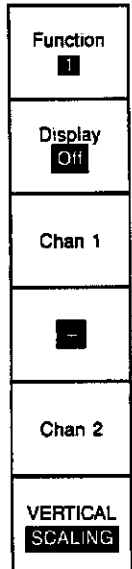

Figure 11-1. Waveform Math Map



## Function Menu

After you have entered the Wfm Math menu, Function 1 or 2 will be displayed. A waveform math function must now be defined. The figure on the left is Function 1 and the following paragraphs give an explanation of each key.



**Function Key**

This key allows you to select either Function 1 or Function 2

**Display Key**

The Display Key allows you to turn the selected Function on or off. When the display for a function is turned on, the vertical deflection factor is displayed below the waveform display area and the offset in Volts is displayed with the Function.

**First Operand Key**

This key selects the first operand of the mathematical operation. The operand may be one of the two channels, or you may choose a waveform stored in one of the memories. When the oscilloscope is in the Real Time mode, only memories one through four may be selected. In the Repetitive mode only memories five through eight are accessible. Memories can only be used in a function if a waveform has been stored into it.

The operand choices are remembered with the mathematical function. In the example display at the left, the subtract ( - ) function is stored with the operands Chan 1 and Chan 2. Therefore, the math function should be selected first before the operand choices are made.

**Operation Key**

This key allows you to select one of the mathematical operations.

**Second Operand Key**

This key allows you to select the second operand of the mathematical operation. The same selections are available as the for the first operand key.

**Scaling Key**

When the Scaling key is displayed, the function displayed may be scaled. The key toggles between SCALING and OFFSET. Scaling factors are displayed at the top and bottom of the waveform display area.

---

## **Function Scaling**

Vertical scaling is provided for all mathematical functions except Versus, Minimum and Maximum. Scaling is a method of readjusting vertical sensitivity; therefore you can select vertical sensitivity and reposition the function trace on screen. The Scaling key toggles between VERTICAL SCALING or VERTICAL OFFSET. To change vertical sensitivity or offset, use any of the front panel entry devices.

The scaling factors are stored with the mathematical function used. This feature allows you to define another function and retain scaling data with the previous function.

### **Default Scaling**

Default scaling forces the results of a function to be rescaled and displayed on screen if the scalefactors have been misadjusted. Default scaling is executed every time a new operand is selected. If the function amplitude is adjusted out of range, the waveform may be restored to the screen by toggling through the operands.

### **Time Scaling**

In cases where the operands are not of the same time scale, the first operand will determine the timebase scale for the function. The timebase scale for the function is displayed below the waveform display area. Time scaling cannot be changed as long as the function menu is displayed.

---

## Vertical Scaling Units

The fundamental measuring units of an oscilloscope are Volts/Div in the vertical axis and Time/Div in the horizontal axis. This philosophy is used regardless of the mathematical function chosen. No provisions have been made to manage units for all combinations of operands and mathematical functions available for the 54111D.

**The Multiply Example** Apply a +2V signal to Channel 1 and a -3V signal to Channel 2. Choose a Function and select math function MULTIPLY ( \* ).

Notice that the result displayed is in fundamental units of -6V, even though the actual units are volts squared.

**The Integrate Example** The integral of an operand is calculated as summation of Volt/Time.

Apply a +2V dc signal to Channel 1.  
Set the Timebase to 100ms/Div.  
Choose a Function and select the INTEGRATE math function.  
Set vertical scaling to 1V/Div.

The actual units of the integrate function are Volt seconds/Div, however, the display shows the fundamental units of Volt/Div.

---

## **Math Function Definitions**

The next paragraphs give a brief description of each mathematical function. A mathematical function is selected by pushing the Operation Key until the desired function is displayed on screen, next to the key.

**Versus** The Versus function draws a Volts versus Volts display of the two selected operands. Vertical Scaling is not available for this function. This mathematical function can not be stored in memory.

**Only** The Only function allows you to display the first operand and scale it.

**Plus ( + )** The two selected operands are added together in this function. Addition proceeds on a point by point basis.

**Subtract ( - )** The Minus operation allows you to subtract any two operands. As in the Plus function, subtraction proceeds on a point by point basis.

**Invert** The Invert function inverts the data of the first operand. Default scaling is determined by the operand. User scaling is also provided.

**Minimum** The first operand value is compared to the current function value. An equal to or the lesser value is stored into the function. The comparisons are made on a point by point basis. Default scaling is determined by the original operand.

**Maximum** This function operates in the same manner as Minimum. Here, the operand value is compared to the function value and an equal to or greater value is stored into the function.

**Multiply** The Multiply function calculates the voltage product of the two specified operands. Multiply is also executed on a point by point basis.

**Integrate** The Integrate function calculates the integral of the vertical value of the designated operand. Integration proceeds on a point by point basis. If a no data point is encountered in the operand, then integration uses the next valid data point. Any non-existing data points encountered are not summed only the available data is integrated. Default scaling is determined by the original operand.

---

### **Function Display**

The Functions are displayed in different screens depending on the SCREEN mode chosen. If Single screen is chosen, then both functions are displayed in the same screen. This is the only screen mode that allows you to overlap both functions. In the Dual mode, Function 1 will be displayed in the top screen and Function 2 will be displayed in the bottom screen. In the Quad mode, Function 1 and 2 are displayed in the third and fourth screens from the top.

---

## Waveform Math Exercise

In this exercise you will use the Wfm Math menu to subtract and add two operands.

**Instrument Setup** Set up the HP 8116A as follows:

- Normal mode
- Frequency = 1 MHz
- Amplitude = 2 V
- Offset = 0 V
- Function = Sine wave

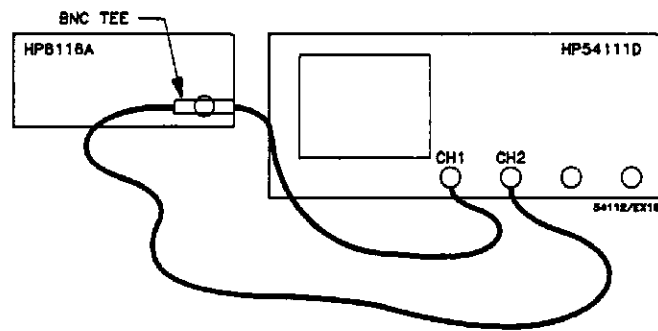

*Figure 11-2. Equipment Set-up*

Set up the HP 54111D as follows:

- Install the BNC tee to output of function generator
- Connect one end of a coaxial cable to one end of the tee and the other end to the BNC on channel 1.
- Connect the other coaxial cable from the other end of the tee to channel 2.
- Set input impedance of Channel 2 to 50  $\Omega$ . See figure 11-2 for the equipment set up.

- Press AUTO-SCALE
- Enter the Display menu and select Repetitive mode and dual Screen.

**Subtract ( - )  
Math Function**

- Enter Wfm Math Menu and select Function 1. Select the Subtract ( - ) math function and select Chan 1 as the first operand and Chan 2 as the second operand.
- Turn Function Display on. Notice that the function display shows 0V (see figure 11-3).

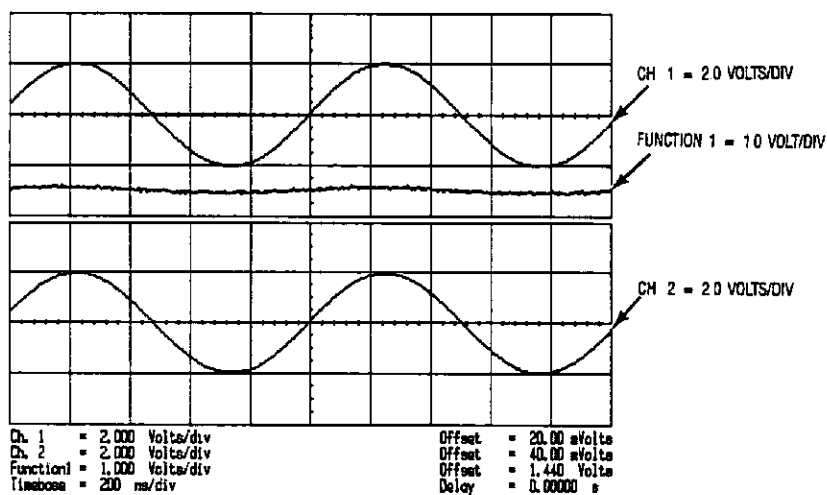
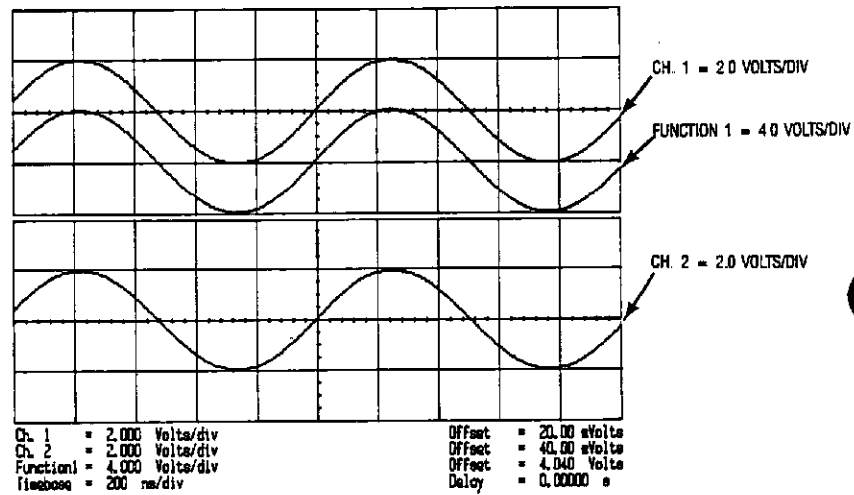

*Figure 11-3. Subtracting Two Operands*

If you would like to keep this data for future reference, you can store Function 1 in one of the waveform memories. To characterize this function, select the Measure menu and use any of the automated measurements.

**Plus ( + )** In this procedure you will add two operands.  
**Math Function**

- Using the same equipment set-up, select the Plus ( + ) math function, Chan 1 as the first operand and Chan 2 as the second operand.
- Turn the Function Display on. Notice that the function display shows 4V (see figure 11-4).



*Figure 11-4. Adding Two Operands.*



# 12

## MEASURE MENU

---

### Section Contents

– Description of the automatic waveform measurements

---

### Overview

The Measure menu is your access to the HP 54111D's twelve automatic measurements. You can measure twelve waveform parameters simply by pressing the All key, or you can select each measurement individually. These automatic measurements conform to the IEEE standard 194-1977, "IEEE Standard Pulse Terms and Definitions"—see Appendix C for information on how the oscilloscope makes automatic measurements.

You can also document the results of the measurements with either an HP-IB printer or plotter—see "Hardcopy Menu," Chapter 13 for details.

After you have selected the Measure menu, you can use three measure-function menus that you can cycle through by pressing the more key (bottom key in the function menu).

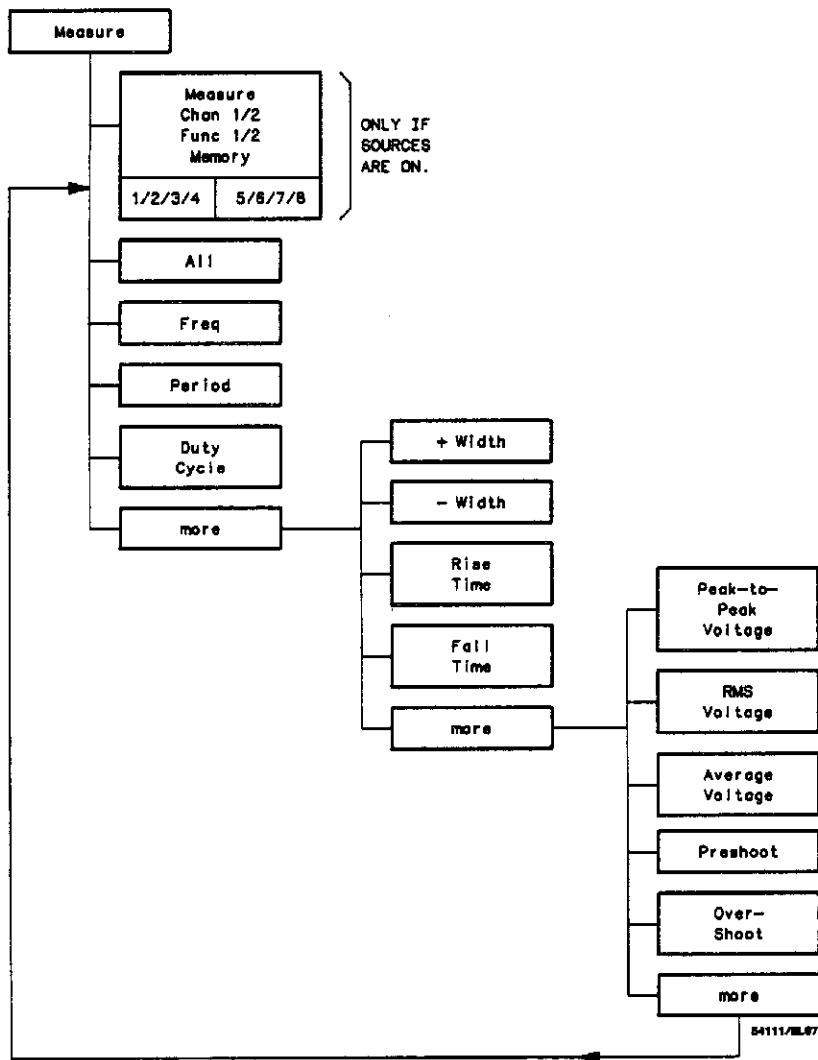

Figure 12-1. Measure Menu.

---

## Measure Key

The Measure key (top of the function menu) allows you to:

- select the waveform source to be measured.

### Note

*To measure a source, it must be turned on (i.e., it must be displayed).*

You may select from the following:

- channels 1 and 2
- functions 1 and 2
- memories 1-4 when the HP 54111D is in the real-time mode
- memories 5-8 when the HP 54111D is in the repetitive mode

---

## All Key

Pressing the All key:

- causes the 54111D to automatically make the measurements listed below and displays the results at the bottom of the CRT.

Measure Chan 1
All
Freq
Period
Duty Cycle
more

Freq (Frequency)	+ Width	Peak-to-Peak Voltage
Period	- Width	RMS Voltage
Duty Cycle	Rise Time (10-90%)	Average Voltage
	Fall Time (90-10%)	Preshoot
		Overshoot

Any of these measurements can be made independently by pressing the appropriate key.

When a measurement is made, the voltage and time markers are automatically placed on the signal based on the screen window. Thus, if you change the window by panning or zooming, the measurements will change accordingly. The points where the markers intersect the signal indicate the data points used to make the measurement.

# 13

## Hardcopy Menu

### Section Contents

The Hardcopy Menu allows you to get a hardcopy of all screen data with either an HP-IB graphics printer or a plotter without an external controller. The hardcopy will include the displayed waveform, measurement factors, graticule and time references. This chapter contains information on how to configure the system and a description of all the hardcopy keys.

### Configuring the System

The following settings are necessary when making a hardcopy using the HP 54111D:

- After displaying the waveform to be copied, push Utility key and select the HP-IB Menu.
- Set the HP54111D to talk only mode (see figure 13-1).

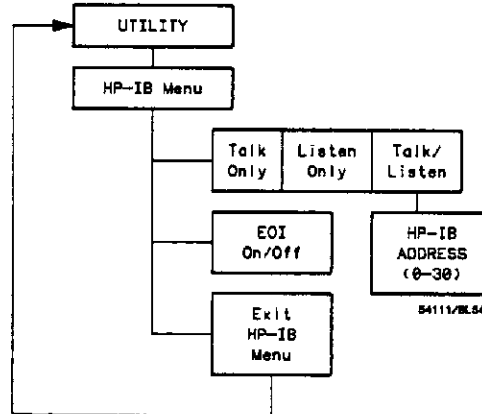

Figure 13-1. HP-IB Menu

- Set the printer or plotter to "Listen Only" or "Listen Always." If there is no Listen Only switch, set the address of the printer or plotter to 31 (all 1's on the address switch). This is an invalid address and will automatically set the peripheral to the "Listen Only" mode.
- Initialize the printer or plotter by cycling power.

## Hardcopy Menu

The Hardcopy menu is divided into two parts: the Printer Menu and the Plotter Menu. The Printer Menu allows you to select the printer type and automatic Form Feed On/Off (see figure 13-2).

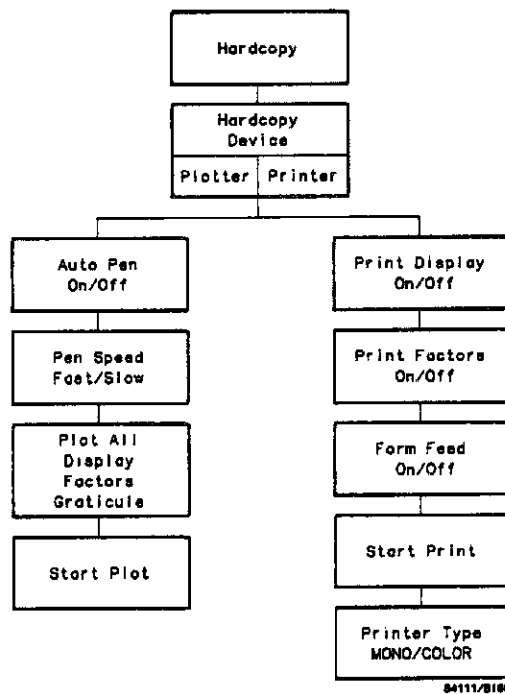

Figure 13-2. Hardcopy Menu Map

The Plotter Menu allows Auto Pen On/Off and Pen Speed choices. Both menus allow you to plot or print just the display, the measurement factors, graticule, or everything displayed on screen (see figure 13-2).

### The Printer Menu

To Print waveform data, push the Hardcopy key and select Printer as the hardcopy device. The figure on the left shows the Printer Menu.

Hardcopy Device <b>Printer</b>
Print Display <b>On</b>
Print Factors <b>On</b>
Form Feed <b>Off</b>
Start Print
Printer Type <b>Mono</b>

**Hardcopy Device** This key allows you to select the peripheral device for hardcopy. You can select either Printer or Plotter.

**Print Display** When the Print Display key is on, both the waveform and the graticule will be printed.

**Print Factors** When On, the measurement factors displayed under the waveform area will be printed.

**Form Feed** If Form Feed is on, the paper in the printer will automatically form feed after the print is complete.

**Start Print** After all options have been selected, press Start Print to begin printing.

**Printer Type** This key selects an HP Graphics printer or the HP PaintJet Printer. After the print sequence has begun, the printer menu is substituted by an another menu containing the following two options:

<b>Pause</b>
Continue

**Pause/Continue** This option allows you to stop the print sequence until you push the Continue key again.

Abort Hardcopy
----------------

**Abort Hardcopy** This key stops the printing sequence entirely.

---

## The Color Printer

The oscilloscope is compatible with the HP PaintJet printer. With four exceptions, the PaintJet color assignments correspond to those on the display and the color menu of the instrument. These exceptions are necessary for better veiwability of the printed data. This means that changing color settings in the color menu, will in some cases change different elements of the output display on the PaintJet printer. The assignments are listed below:

Display	Display Color No.	PaintJet Output
Stored Traces	7 (White)	2 (Halfbright)
Background	0 (Black)	7 (White)
Overlap	8, 11-15 (Magenta)	0 (Black)
Channel 1	4 (yellow)	8 (Magenta)

Example: If the background (color 0) menu is changed to blue, the PaintJet background will remain white, while the overlap will become blue.

## Plotter Menu

To plot waveform data, push the Hardcopy key and select Plotter as the hardcopy device. The figure on the left shows the plotter menu. Any plotters that are compatible with HP-GL (Hewlett-Packard Graphics Language) may be used as the hardcopy device.

Hardcopy Device Plotter
Auto Pen On
Pen Speed Fast
Plot All
Start Plot

**Hardcopy Device** This key allows you to select the peripheral device for hardcopy. You can select either Printer or Plotter.

**Auto Pen** The HP 54111D supports multi-pen plotters. If the Auto Pen option is on, the plotter selects a new pen when a different portion of the screen data is to be plotted.

The pen selection is as follows:

Pen No.	Usage
1	Graticule, timebase factors, channel 3, function 1 and associated factors.
2	Channel 1 and associated factors.
3	Waveform memories and associated factors and both pixel memories.
4	Channel 2 and associated factors.
5	Channel 4, function 2 and associated factors

If Auto Pen is off, the plotter does not change pens when a new screen item is to be plotted.

**Pen Speed** The Pen Speed key allows you to select fast or slow speeds if the plotter has that capability. If the Display is in the persistence mode (repetitive display mode with averaging off), or if you are plotting pixel memories, the output from the HP 54111D causes the plotter to plot each data point of the display.

In the realtime mode, all data points displayed on screen are plotted. In all other cases, waveforms are plotted in a continuous line.



Hardcopy Device Plotter
Auto Pen On
Pen Speed Fast
Plot All
Start Plot

**Plot All** When pushed, the Plot All key toggles through Plot All, Plot Display, Plot Factors, and Plot Graticule. In the Plot All mode, everything displayed on screen is plotted. In the other modes only the selected portion of the screen is plotted.

**Start Plot** When this key is pushed the plotter sequence starts.

While the plotter sequence is in progress, the original menu is substituted with another containing the following options:

Pause
Continue

**Pause/Continue** This key allows you to momentarily interrupt the plotting sequence. When the Continue key is pushed, plotting will continue from the point of interruption.

Abort HardCopy
-------------------

**Abort** This key allows you to discontinue plotting entirely and return to the menu.

# 14

## UTILITY MENU

---

### Section Contents

- Description of the utility functions, including probe attenuation, HP-IB interface, self-calibration, color control, and CRT setup
  - Exercises illustrate how to set the attenuation factors and change the colors on the display
- 

### Overview

Probe Menu
HP-IB Menu
Cal Menu
Test Menu
Color Menu
CRT Setup Menu

The Utility menu key allows you to access six submenus that are displayed in the function menu area. These submenus are:

- Probe Menu
- HP-IB Menu
- Cal Menu
- Test Menu
- Color Menu
- CRT Setup Menu

The function keys for each menu are accessed by pressing the appropriate key.

The Test Menu and the CRT Setup Menu are discussed in the *HP 54111D Service Manual* and are not covered here.

---

## Probe Menu

- Overview** After you have selected the Probe Menu:
- you may select any of the four inputs.
    - you can enter any attenuation ratio from .1 to 1000.
    - if an HP 10033A probe is attached to the input, the range is 1 to 10,000.

CHANNEL 1 PROBE ATTEN
CHANNEL 2 PROBE ATTEN
TRIGGER 3 PROBE ATTEN
Exit Probe Menu

You can use any of the entry devices to enter the attenuation ratio.

When you define a probe attenuation factor:

- the actual sensitivity at the BNC input of the instrument does not change.
- when attenuation factors are changed, all voltage displays and voltage markers are adjusted accordingly.

The attenuation factors are stored along with the rest of the front-panel setup in the Save/Recall registers.

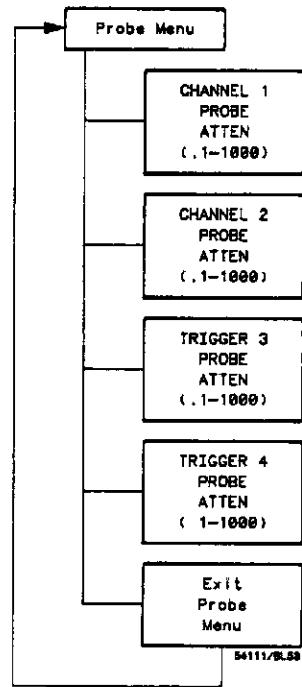

Figure 14-1. Probe Menu.

When an HP 10033A probe (or other probe with a sense ring contact is) attached, the attenuation factor is multiplied by 10; when detached, the attenuation factor is divided by 10. For example, if the attenuation factor is 1.510 and then the probe is attached, the attenuation factor becomes 15.10.

At power up, the attenuation factor will either be set to 1:1 if no probe is attached, or set to 10:1 if an HP 10033A probe is attached to the input (i.e., probe attenuation factors are not saved at power down).

## HP-IB Menu

**Overview** Select the HP-IB menu when you need to connect the HP 54111D to other HP-IB devices.

After you have selected the HP-IB menu, you may set the HP-IB mode to:

- Talk Only
- Listen Only
- Talk/Listen
- when Talk/Listen is selected, the HP-IB ADDRESS key is activated (the default address is 7).

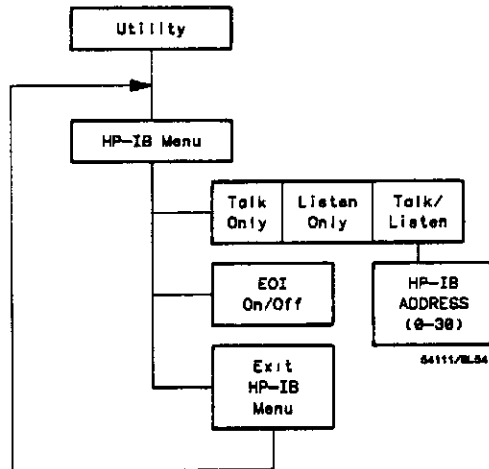
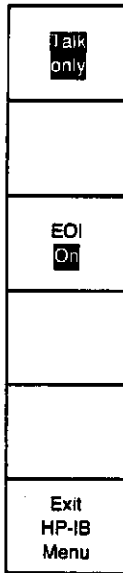

Figure 14-2. HP-IB Menu.

**EOI Key** The EOI (end or identify) key allows you to invoke this HP-IB function. When EOI is "On," the HP 54111D will identify the last byte of a multibyte sequence. The default condition for EOI is "On."

FOR MORE DETAILS...refer to the *HP 54111D Programming Reference Manual* for a complete discussion of the HP 54111D's HP-IB capabilities.

---

## Cal Menu

### Overview

The Cal Menu allows you to:

- calibrate the HP 54111D's analog-to-digital converters
- calibrate to the probe tip
- calibrate vertical sensitivity
- calibrate trigger levels and hysteresis
- calibrate the timebase reference frequency and channel-to-channel skew

ADC Reference Cal
Probe Tip Cal
Vertical Cal
Trigger Cal
Timebase Cal
Exit Cal Menu

The HP 54111D must be calibrated if the advisory "Front Panel Calibration Needed" is displayed during power up. This occurs when:

- battery pack failure occurs.
- microprocessor or I/O assemblies have been removed.
- two-key down power up (page 14-19) is performed.

**CAUTION**

*It is also possible that instrument traceability (e.g., U.S. NBS traceability) will be lost if a two-key down power up is performed.*

A one-key down power up (page 14-19) sets the oscilloscope to the default conditions—see Table 1-1 in the *HP 54111D Programming Reference Manual* for a list of the reset conditions.

A two-key down power up sets the oscilloscope to the default conditions, just as the one-key power up does. It also erases all software calibration factors and replaces cal factors with defaults. If a two-key down power up is performed, a complete software recalibration is required. The procedure to perform this is listed below. The recalibration can be done by the user. The reason this can be done by the user is that the software calibration routines have been designed to ensure that calibration traceability is maintained.

To ensure traceability, follow these three rules:

- perform the software calibration routines in the order specified in the procedure below.
- ensure that the calibration sticker is not outside its calibration interval. This is important because the calibrator signal is only specified during this interval.
- the value that the user enters into the Timebase Freq Cal should be the same value that was recorded on the test record that was returned by the calibration lab from which the traceability originated.

When you select the Cal menu, the following submenu appears:

- ADC Reference Cal
- Probe Tip Cal
- Vertical Cal
- Trigger Cal
- Timebase Cal
  - Channel Skew
  - Timebase Freq Cal

If you wish to perform the software calibration routines on the instrument, perform them in the order listed below:

- Vertical Cal
  - the ADC Reference Cal is automatically performed as part of the Vertical Cal cycle, but can be done separately or in addition to the other calibration routines if desired.
- Probe Tip Cal
- Trigger Cal
- Timebase Cal

### Note

*When the HP 54111D is turned on, a self test is automatically performed and a message appears indicating whether the instrument passed or failed the self test. If the instrument fails, let it run for fifteen minutes (warm-up cycle), then perform the software calibration routines. Cycle the power, and if the instrument still fails the self test, contact your nearest Hewlett-Packard Service Center.*

- ADC Reference Cal** The ADC Reference Cal allows you to:
- set reference voltages to eliminate any gain/offset differences between the four converters in each channel. For a description of the acquisition system, please refer to the theory of operation section of the *HP 54111D Service Manual*.

**Instrument Setup** — It is desirable that signals be disconnected from inputs.

### Note

*Inputs larger than 2 volts may affect the calibration routine. The effect of smaller signals is negligible.*

**ADC Reference Cal Procedure** — Enter the Cal menu by selecting the Utility menu and then the Cal menu.

ADC Reference Cal offers two modes, which can be selected using the increment/decrement keys when the Cal menu is displayed:

- auto mode
- manual mode

If Auto is selected:

- The HP 54111D automatically performs an ADC reference calibration on its A/D converters for both channels when its operating system determines that this is necessary.

This Calibration is performed (if needed) at the start of an acquisition cycle before the "Awaiting Trigger" advisory is displayed. This is designed so that the calibration routine will not interfere with a single-shot capture after "Awaiting Trigger" is displayed. If "Awaiting Trigger" is displayed for a long time, an ADC reference



calibration should be initiated manually if this will not interfere with the trigger event.

When the HP 54111D is awaiting a trigger, the ADC reference calibration is disabled. However, it is important to note that the instrument's ADC references may drift while awaiting a trigger. If the ambient temperature is steady, drift is insignificant; drift becomes significant when the ambient temperature changes by more than 5 degrees F (2.5 degrees C) during the time when calibration is disabled.

There are two ways to avoid problems from this phenomenon:

- generally, it is sufficient to keep the HP 54111D in a "Stopped" status until 30 seconds before the trigger. While "Stopped," the HP 54111D will calibrate itself.
- perform an ADC reference calibration (see Chapter 14, "Utility Menu") just before setting the HP 54111D to trigger on the event. This procedure can be initiated over the bus under program control by simulating key presses—as described in the *HP 54111D Programming Reference Manual*, Chapter 2, Key command.

If Manual is selected:

- the instrument will not automatically calibrate when needed. If the instrument determines that a calibration is needed, the ADC Reference Cal key turns red and flashes.

To start calibration:

- press the ADC Reference Cal key.
  - the advisory "Calibrating A to D references" will be displayed on the screen.
  - calibration is completed when the advisory is removed.

ADC Cal failure is indicated by the appearance of more than one trace on a single channel or the trace being greatly displaced (figure 14-3).

- contact a Hewlett-Packard Service Center if the instrument fails to calibrate.

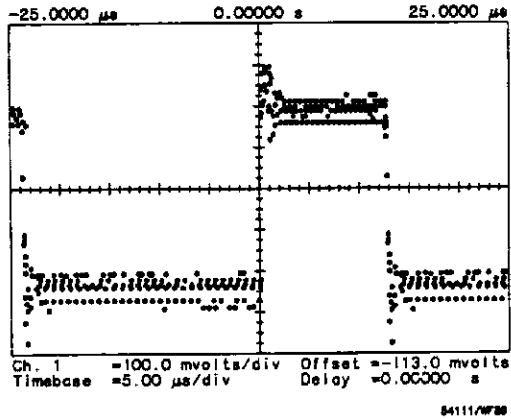

Figure 14.3. Multiple Traces on a Single Channel Indicate an ADC Reference Cal is Needed.

**Note**

You may see a display such as that in figure 14-3 if the HP 54111D has been set to manual mode and the ADC reference cal has subsequently drifted. Check this before calling the HP Service Center.

**Probe Tip Cal**

The Probe Tip Cal:

- enables calibration from the probe tip through the A/D converters.

**Instrument Setup** — Connect the front-panel CAL signal through a 10:1 probe to the channel 1 input.

**Note**

If you change probes, you must perform a probe tip cal.

**Probe Tip Cal Procedure** — The following procedure refers to channel 1, but it can be used to calibrate any of the four inputs as needed.

Calibrate Probe Tip CHAN 1
Calibrate Probe Tip CHAN 2
Calibrate Probe Tip TRIG 3
Calibrate Probe Tip TRIG 4
Exit

Enter the Cal menu by selecting the Utility menu and then the Cal menu.

- select the Probe Tip Cal key:
  - Probe Tip Cal menu will then be displayed.
- select Calibrate Probe Tip CHAN 1 key.

The screen will clear and then display a set of instructions with a new function menu. Follow the instructions by:

- connecting the front-panel CAL signal through an HP 10033A probe to channel 1.
- pressing the Continue key when ready to start calibration.

**Note**

*If a 10:1 probe other than the HP 10033A is used, set input impedance to 1 MΩ and coupling to dc.*

When the calibration has started:

- the advisory “Performing CHAN 1 calibration to probe tip” will be displayed.
- a counter (moving arrow) will travel across the CRT during calibration.

When the calibration is complete:

- the HP 54111D will automatically return to the Probe Tip Cal menu.

If the Exit key is pressed before the calibration procedure is complete:

- if the advisory “Channel 1 Input Gain Calibration Aborted” is displayed on screen:
  - the instrument will return to the Probe Tip Cal menu.

Probe Tip Cal failure is indicated by incorrect vertical scaling:

- contact a Hewlett-Packard Service Center if the instrument fails to calibrate.

**Vertical Cal** Vertical Cal allows you to:

- software calibrate vertical sensitivity and offset.

**Instrument Setup** — All inputs to CHAN 1 and CHAN 2 must be disconnected.

**Vertical Cal Procedure** — Enter the Cal menu by selecting Utility and then the Cal menu.

Press the Vertical Cal key:

- the advisory "Remove probes from CHAN 1 and CHAN 2 inputs. Press Continue when ready" will be displayed on the screen.

To start calibration:

- remove all probes from inputs and press Continue.

When the calibration has started:

- the advisory "Setting up hardware for Cal" will be displayed for about two seconds.
- the instrument will then calibrate vertical gain at 49.9 mV, 20.0 mV, 19.9 mV, 10.0 mV, 9.99 mV, 5.00 mV, 4.99 mV, 2.00 mV, 1.99 mV, and 1.00 mV per division.
- a counter (moving arrow) will travel across the CRT during calibration to indicate that the instrument is working.

When calibration is complete:

- the HP 54111D will automatically return to the Utility menu.

If the Exit key is pressed before the calibration procedure is complete:

- if the advisory: "Vertical Calibration Aborted" appears:
  - the instrument will return to the Cal menu and the cal factors will not be changed.

Vertical cal failure is indicated by incorrect vertical gain and/or offset.

- contact a Hewlett-Packard Service Center if the instrument fails to calibrate.

- Trigger Cal** Trigger Cal allows you to:
- calibrate trigger levels and trigger sensitivity (hysteresis).

**Instrument Setup** — All inputs to CHAN 1, CHAN 2, TRIG 3, and TRIG 4 must be disconnected.

**Trigger Cal Procedure** — Enter the Cal menu by selecting the Utility menu and then the Cal menu.

Press the Trigger Cal key:

- the advisory: "Remove probes from CHAN 1 and CHAN 2 inputs. Press Continue when ready" will be displayed on the screen.

To start trigger calibration on channel 1 or 2:

- remove all probes from inputs and press Continue.

When calibration has started:

- If the advisory "TRIG X hardware failure, calibration not possible" appears:
  - that channel has failed the self-test and no calibration will be attempted on that channel.
- If the advisory does not appear:
  - the advisory: "Performing internal vertical trigger calibration of channels Setting sensitivity on CHAN 1" will be displayed on the screen.
  - the instrument will then calibrate the channel's trigger at 20 mV, 10 mV, and 5 mV range.
  - a counter (moving arrow) will travel across the CRT during calibration.

After channel 1 has been calibrated:

- the HP 54111D will automatically repeat the same procedure for channel 2.

When channel 1/2 trigger calibration is complete:

- the advisory: "Remove probes from TRIG 3 and TRIG 4 inputs Press Continue when ready" will be displayed the screen.

To start trigger calibration on TRIG 3 and TRIG 4:

- remove all probes from inputs and press Continue.

When calibration has started on TRIG 3 and TRIG 4:

- the advisory: "Performing internal vertical trigger calibration of channels. Setting sensitivity on TRIG 3" will be displayed on the screen.
- a counter (moving arrow) will travel across the CRT during calibration.

After TRIG 3 has been calibrated:

- the HP 54111D will automatically repeat the same procedure for TRIG 4.

The HP 54111D will automatically return to the Cal menu when the calibration is complete.

If the Exit key is chosen before calibration procedure is complete:

- if the advisory: "Trigger Calibration aborted WARNING: Cal factors may be invalid" appears:
  - then part of Cal factors are invalid.

If the CHAN 1/2 Cal test was interrupted:

- the HP 54111D will automatically exit to the TRIG 3 and TRIG 4 calibration screen.

If the TRIG 3/4 Cal test was interrupted:

- the HP 54111D will automatically return to the Cal menu.

Trigger Cal failure is indicated by incorrect trigger levels and trigger sensitivity.

- contact a Hewlett-Packard Service Center if the instrument fails to calibrate.

**Timebase Cal** Timebase Cal is used to software calibrate:

- channel skew
- timebase frequency

**Channel Skew** — aligns the signal that is input to CHAN 1, CHAN 2, TRIG 3, and TRIG 4.

Alignment occurs at the intersection of the input signal's edge and the HP 54111D's center horizontal graticule. For each input, this point becomes time-aligned with the zero-delay point.

- alignment includes time delays both internal and external to the HP 54111D, including probe or cable length.

It is important to set up the HP 54111D as described below:

- a pulse generator with the following capabilities is required:
  - $\leq 2$  ns rise time.
  - repetition rate  $\geq 500$  kHz.
- signal should have an amplitude of  $>2$  major divisions and  $<8$  major divisions in the single screen mode.
- signal should cross center horizontal graticule with one positive edge (set in the Timebase menu).
- set channel 1/2 trigger levels to center horizontal graticule.
- set trigger 3/4 impedance coupling and trigger levels identical to channel 1.

If these conditions are not met:

- exit the menu and establish the signal conditions specified above.

If the conditions are met:

- press Continue—both channels will be time-aligned to the center graticule.

#### Note

*Do not use the timebase calibration signal from the back of the instrument for the channel-to-channel skew calibration procedure.*

#### Note

*If a signal is used with a risetime  $>2$  ns, the results may not be as accurate on sweep speeds faster than 2 ns/div.*

Recommended setup:

- for best results, run the channel skew cal in a setup similar to your setup.

- for general use, recommended instruments are the HP 8161A and HP 8082A pulse generators.
  - attach the BNC tee and equal-length cables as illustrated in figure 14-4.
  - verify that the above signal conditions are met before starting the calibration process.

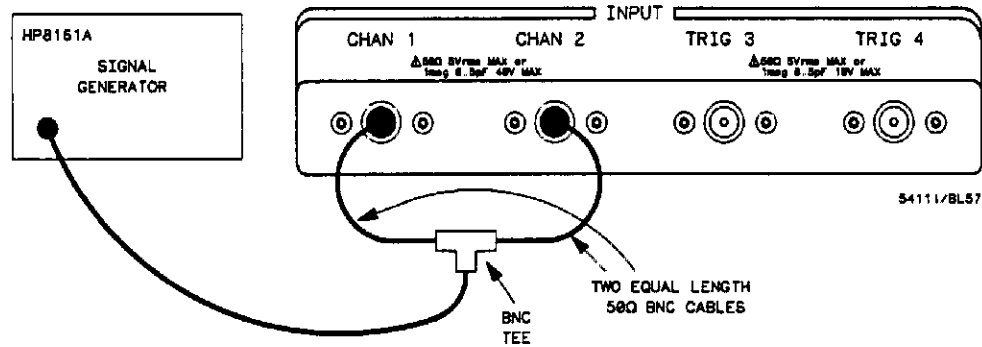

Figure 14-4. Channel Skew Instrument Setup.

**Channel Skew Procedure** – Enter the Cal menu by selecting:

- Utility and then the Cal menu.

Enter the Channel Skew menu by selecting:

- the Timebase Cal menu and then the Channel Skew menu.

Read the advisory and verify that specified conditions are met.

When ready to start calibration:

- press the Continue key.

When calibration has started, the following advisory is displayed:

“Aligning Channel to Channel Skew and CHAN 1 trigger Aligning Trigger for XX ns Sample Period”

- XX indicates 1 ns, 2 ns, 4 ns, 10 ns, 20 ns, 40 ns, 100 ns, 200 ns sample period.



After CHAN 1 has completed aligning itself, the following advisory is displayed:

“Aligning CHAN 2 trigger

Aligning Trigger for XX ns sample period”

– XX indicates 1 ns, 2 ns, 4 ns, 10 ns, 20 ns, 40 ns, 100 ns, 200 ns sample period.

After CHAN 2 has been aligned to CHAN 1, the following advisory is displayed:

“Connect Common Signal Source to CHAN 1 and TRIG 3. Press Continue when ready”

– follow the instruction by removing the BNC cable from CHAN 2 and connecting it to TRIG 3.

When ready to start calibration:

- press the Continue key.

When calibration has started, the following advisory is displayed:

“Aligning TRIG 3

Aligning Trigger for XX ns Sample Period”

– XX indicates 1 ns, 2 ns, 4 ns, 10 ns, 20 ns, 40 ns, 100 ns, 200 ns sample period.

After TRIG 3 has been aligned to CHAN 1, the following advisory is displayed:

“Connect Common Signal Source to CHAN 1 and TRIG 4

Press Continue when ready”

– follow the instruction by removing the BNC cable from TRIG 3 and connecting it to TRIG 4.

When ready to start calibration:

- press the Continue key.

When the calibration has started, the following advisory is displayed:

“Aligning TRIG 4

Aligning Trigger for XX ns Sample Period”

– XX indicates 1 ns, 2 ns, 4 ns, 10 ns, 20 ns, 40 ns, 100 ns, 200 ns sample period.

After TRIG 4 has been aligned to CHAN 1:

- the instrument will automatically return to the Cal menu.

If the Exit key is chosen before calibration procedure is completed:

- if the advisory:  
"Channel Skew Calibration aborted  
WARNING: Cal factors may be invalid"  
appears, then part of Cal factors are invalid.  
– the instrument will return to the Cal menu.

If setup is incorrect:

- the advisory "Signal not found, Calibration aborted" will be displayed on the screen
- the instrument will automatically return to the Cal menu.

**Timebase Freq Cal** – Allows you to:

- calibrate to improve the accuracy of time-interval measurements made with the HP 54111D.

**Instrument Setup** – connect the Timebase Cal output from the rear panel of the instrument to a frequency counter with a 50  $\Omega$  BNC cable.

- the counter should be able to count at least 51 MHz at an input level of  $-200$  mV to  $-400$  mV square wave (HP 5315A or HP 5384).

#### **Note**

*To maintain a traceable calibration (e.g., U.S. National Bureau of Standards), you must use a traceable frequency counter. The Timebase Frequency Calibration is not a calibration that should normally be done by the user because if not performed correctly, then Timebase Calibration can be lost. Please refer to the HP 54111D Service Manual for more information.*

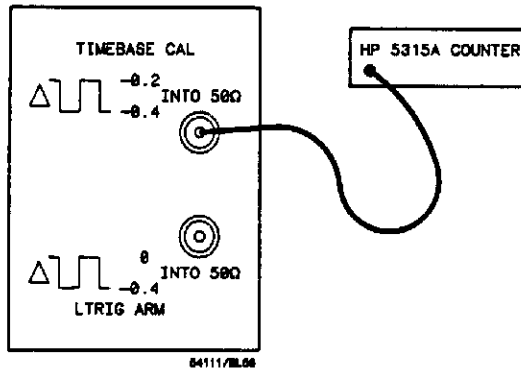

Figure 14-5. Timebase Freq Cal Instrument Setup.

**CAUTION**

*This adjustment affects timebase traceability. Press Exit to preserve your present calibration.*

**Timebase Freq Cal Procedure** - Enter the Cal Menu by selecting:

- the Utility menu and then the Cal menu.

Enter the Timebase Freq Cal menu by selecting:

- the Timebase Cal menu and then the Timebase Freq Cal menu.

In the Timebase Freq Cal menu the following advisory will be displayed on screen:

Connect rear panel TIMEBASE CAL output to frequency counter. Enter results using keypad and press Continue.

Acceptable range is 50000000 to 50100000

Current value is \_\_\_\_\_  
 Frequency \_\_\_\_\_ Hz

After the instrument is set up and the Timebase Freq Cal is selected:

- read the frequency from the counter.
  - the frequency output will change when Timebase Freq Cal menu is entered.
- follow the instructions by:
  - entering the frequency reading (enter eight digits) from the frequency counter into the HP 54111D with the use of the Enter keypad.

If the Exit key is pressed before calibration:

- previous calibration factors will be saved.
- the instrument will return to the Cal menu.

To start calibration:

- press Continue.

When calibration is complete:

- the HP 54111D will automatically return to the Cal menu.

**One-Key Down  
Power UP**

A one-key down power up is an instrument preset. It causes the instrument to power up in a known state (table 1-1, page 1-13). To perform a one-key down power up, turn the front-panel power switch to STBY. Now press and hold down the bottom function key (along the right side of the CRT) until all test patterns have been completed and the "Power-up Self Test Passed" message is displayed on the CRT. While still holding the key down, turn the power switch to ON.

**Two-Key Down  
Power UP**

A two-key down power up is a hard reset of the instrument. It completely clears the memory (i.e., clears everything stored in RAM), including all cal factors (channel-to-channel skew, vertical gain/offset, probe tip, timebase frequency cal) and setup information stored in the save/recall registers. To perform a two-key down power up, turn the front-panel power switch to STBY. While holding down the top and bottom function keys (along the right side of the CRT), turn on the instrument and hold down the keys until the CRT displays a pass/fail advisory (within approximately 30 seconds). The instrument is not operable until 30 minutes after the two-key down power up is performed. A signal source and frequency counter are required to re-establish the cal factors after the two-key down power up.

---

## Color Menu

- Overview** The color menu allows you to:
- define the 16 (0-15) color fields available on the HP 54111D.
    - all 16 fields can be individually modified to suit a specific need.

Color selections are maintained in non-volatile memory and are part of the Save/Recall memories.

After you have selected the Utility menu and the Color menu:

- use the Color Field key (top key) or one of the entry devices to select the color number you wish to change.
- then use the HUE, SATURATION, and LUMINOSITY functions to modify it.

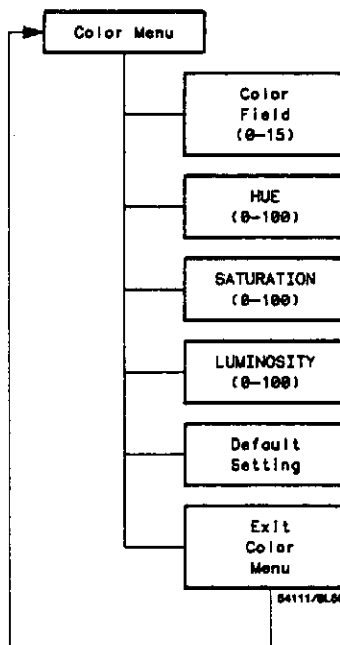
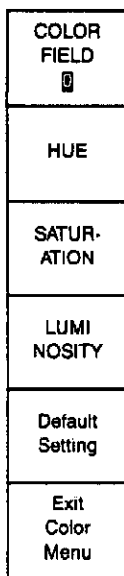

Figure 14-6. Color Menu.

- Hue Key** The HUE key allows you to
- change the color:
    - the range is from 0 to 100, with red located at 0/100, green at 33, and blue at 67.
    - you can use any of the entry devices.
- Saturation Key** The SATURATION key allows you to:
- define the percent of pure color that is to be mixed with white:
    - the range is from 0 to 100, with 0 being white (regardless of the hue setting) and 100 being the pure color (determined by hue).
    - use any of the entry devices.
- Luminosity Key** The LUMINOSITY key allows you to:
- define the relative brightness of the color:
    - the range is from 0 to 100, with 0 being black and 100 being maximum brightness.
    - use any of the entry devices.
- Default Setting Key** The Default Setting key allows you to:
- set all colors to their default states (see table 14-1).

Table 14-1. Default Color Settings.

COLOR #	COLOR	USE	HUE	SATURATION	LUMINOSITY
0	Black	Background	0	0	0
1	Beige	Highlighting	12	51	100
2	Gray	Text (Halfbright)	0	0	55
3	Red	Advisory	0	100	100
4	Yellow	Channel 1	17	100	100
5	Green	Channel 2	33	100	100
6	Orange	Markers	11	100	100
7	White	Stored traces (when selected)	0	0	100
8	Magenta	2 trace overlap	90	100	100
9	Tangerine	Function 1	8	100	100
10	Blue	Function 2	53	85	90
11	Magenta	Memory bar	90	100	100
12	Magenta	3 trace overlap	90	100	100
13	Magenta	2 trace + memory overlap	90	100	100
14	Magenta	3 trace + memory overlap	90	100	100
15	Magenta	4 trace + memory overlap	90	100	100

# 15

## SPECIFICATIONS AND OPERATING CHARACTERISTICS

---

### Introduction

This section contains a list of specifications for reference and performance verification. This section also includes supplemental characteristics which are typical parameters that are included in this manual as additional information.



**VERTICAL  
(VOLTAGE)**

**Specifications\*\*\*\***

<b>Channels</b>	2	
<b>Bandwidth (-3dB)*</b>	<b>Real-time</b>	<b>Repetitive</b>
dc-coupled	dc to 250 MHz	dc to 500 MHz
ac-coupled	10 Hz to 250 MHz	10 Hz to 500 MHz
<b>Transition Time (10% to 90%)</b>	See "Operating Characteristics"	700 ps
<b>Deflection Factor (full scale=8 div)</b>	1 mV/div to 5 V/div continuous	
<b>Resolution (% of full scale)</b>	8 bits to 25 MHz (0.4%), 7 bits to 100 MHz (0.8%), 6 bits to 250 MHz (1.6%),	6 bits (1.6%), 8 bits with averaging to 500 MHz (0.4%)
<b>DC Gain Accuracy</b>	±2% of full-scale**	
<b>DC Offset Accuracy</b>	±1.5% of setting ±0.2 div***	
<b>DC Measurement Accuracy single data point</b>	±Gain Acc ± Offset Acc ± Resolution	
<b>between data points on the same waveform</b>	±Gain Acc ± 2 x Resolution	
<b>DC Offset Range</b>	±200 mV (1 mV/div to 4 mV/div) ±1 V (5 mV/div to 49 mV/div) ±10 V (50 mV/div to 499 mV/div) ±40 V (500 mV/div to 5 V/div)	
<b>Input Coupling</b>	ac/dc/dc-50 Ω/gnd	
<b>Maximum Safe Input Voltage</b>	±40 Volts @ 1 MΩ (dc +peak ac), 5 Vrms @ 50 Ω	

**Note**

All voltages in table correspond to a 1:1 attenuation setting. If a 10:1 probe is attached, multiply all voltages by ten. The HP 10033A has a maximum voltage of ±200 V.

\* Bandwidth for settings 1 mV/div to 4 mV/div is reduced to 150 MHz.

\*\* When calibrated to probe tip using the front panel calibration source. Applies to major ranges (5 mV/div, 10 mV/div, 20 mV/div, 50 mV/div, 100 mV/div, 200 mV/div, 500 mV/div, 1 V/div, and 2 V/div). All continuous settings between these ranges are ±3% of full-scale. All settings between 1 mV and 4 mV/div are ±4% of full-scale.

\*\*\* Increases to ±0.4 divisions at 5 mV/div to 9 mV/div, and ± 1 division below 5 mV/div.

\*\*\*\* Applies for temperature ranges ±5° C from point of last software calibration.

**HORIZONTAL  
(TIME)**

	Real-time	Repetitive
<b>Digitizing Rate</b>	1 gigasample/s to 50 sample/s	
<b>Deflection Factor</b>	500 ps/div to 1 s/div	
<b>Memory Depth Per Channel</b>	8k	501
<b>Pre-trigger Delay Range</b>	-8 $\mu$ s at timebase settings 50 ns/div and faster, increasing to -160 sec at 1 s/div.	
<b>Post-trigger Delay Range</b>	0.16 s at timebase settings 500 ns/div and faster, increasing to 10,000 seconds at 1 s/div.	
<b>Time Interval Measurement Accuracy</b>		
<b>single channel</b>	$\pm 300$ ps* $\pm 0.03\%$ of reading	$\pm 100$ ps* $\pm 0.03\%$ of reading
<b>dual channel</b>	$\pm 600$ ps** $\pm 0.03\%$ of reading	$\pm 200$ ps** $\pm 0.03\%$ of reading

\* Decreased to ( $\pm 2\%$  of time range  $\pm 0.03\%$  of reading) for time ranges 200 ns and slower. Time range is (time/div  $\times$  10).

\*\* Decreased to ( $\pm 4\%$  of time range  $\pm 0.03\%$  of reading) for time ranges 200 ns and slower. Time range is (time/div  $\times$  10).

## TRIGGERING

Sources	Internal Channels 1,2	External Trig. 3,4
Sensitivity	0.1 of full-scale, dc to 200 MHz*	15 mV (high sensitivity)** dc to 200 MHz
	0.2 of full-scale, 200 MHz to 500 MHz*	45 mV (high sensitivity)** 200 MHz to 500 MHz
Trigger Level Range	$\pm 3 \times$ full-scale	$\pm 1$ V (high sensitivity)**
Maximum Safe Voltage	NA	$\pm 10$ volts @ 1 M $\Omega$ (dc + peak ac), 5 Vrms @50 $\Omega$
Input Operating Range	NA	$\pm 1$ V (high sensitivity) dc + peak ac

\* Applies to settings 5 mV/div to 5 V/div.

\*\* For low sensitivity, multiply voltage values by 10.

---

## Operating Characteristics

### VERTICAL

**Real-time Mode Transition Time (10% to 90%):** 1.4 ns.  
Calculated by measuring a 1.4 ns risetime source. In the 6-bit filter mode, a 1.4 ns input risetime is measured as  $2.0 \text{ ns} = \sqrt{(1.4)^2 + (1.4)^2}$

**Input Impedance:** 1 M $\Omega$  at <6.5 pF or 50  $\Omega$ (dc).

**Input Protection:** 50  $\Omega$  input resistance is protected. When maximum safe input voltage is exceeded.

#### DYNAMIC PERFORMANCE (typical):

Input Frequency	Effective bits of resolution				
	1 MHz	20 MHz	90 MHz	250 MHz	500 MHz
6 Bit Mode	5.5 bits	5.5 bits	5.5 bits	5.0* bits	N/A
7 Bit Mode	6.2 bits	6.2 bits	6.0 bits	N/A	N/A
8 Bit Mode	7.2 bits	7.0 bits	N/A	N/A	N/A

\*unfiltered data transferred over HP-IB.

**Channel-to-Channel Isolation:** 60 dB at 500 MHz

---

### HORIZONTAL

**Delay Between Channels:** difference in delay between channels can be front-panel calibrated to compensate for differences in input cables or probe length.

**Reference Location:** the reference point can be located at the left edge, center, or right edge of the display. The reference point is the trigger plus the delay time.

---

<b>TRIGGER</b>	<b>Holdoff</b>	<p><b>Holdoff-by-events:</b> range of events counter is from 2 to 67 million events. Maximum counting rate is 80 MHz. An event is defined as anything that satisfies the triggering conditions selected.</p> <p><b>Holdoff-by-time:</b> adjustable from 70 ns to 670 ms.</p>
	<b>Trigger Modes</b>	<p><b>Edge trigger:</b> on any source.</p> <p><b>Pattern trigger:</b> a pattern can be specified for all sources. Each source can be specified as high, low, or don't care. Trigger can occur on the last edge to enter the specified pattern or the first edge to exit the specified pattern.</p> <p><b>Time qualified pattern trigger:</b> trigger occurs on the first edge to exit the specified pattern, only if the pattern was present for less than [greater than] the specified time. Time is adjustable from 10 ns to 5 seconds. Recovery time is <math>\leq 8</math> ns. In the "Pattern present &lt; [time]" mode, the pattern must be present <math>\geq 1</math> ns for the trigger to respond.</p> <p><b>State trigger:</b> a pattern can be specified for any of the sources. Trigger can be set to occur on an edge of either polarity on the source specified as the clock (not one of the pattern sources) when the pattern is present or not present. Setup time for the pattern to be present prior to the clock edge is <math>&lt; 4</math> ns; hold time is zero. Maximum clock repetition rate is 80 MHz.</p>
	<b>Delay Trigger</b>	<p><b>Events-delayed mode:</b> the trigger can be armed by an edge on any source, then triggered by the nth edge on any other source. The number of events, n, can be set from 1 to <math>10^8 - 1</math>. Maximum event counting rate is 150 MHz.</p> <p><b>Time-delayed mode:</b> the trigger can be armed by an edge on any source, then triggered by the first edge on any other source after a specified time has elapsed.</p>

---

## DISPLAY

**Data Display Resolution:** 501 points horizontally by 256 points vertically.

**Data Display Formats** **Split screen:** channel displays are two or four divisions high, corresponding to quad or dual display mode.

**Full screen:** channels are overlaid and are eight divisions high.

**Display Modes** **Variable persistence:** the time that each data point is retained on the display can be varied from 200 ms to 10 seconds, or it can be displayed in the infinite persistence mode.

**Averaging:** the number of averages can be varied from 1 to 64. On each acquisition,  $1/n$  times the new data is added to  $(n-1)/n$  of the previous value at each time coordinate. Averaging operates continuously; the average does not converge to a final value after  $n$  acquisitions, except over HP-IB.

**Graticules:** Full grid, axes with tic marks, frame with tic marks, or graticule off.

**Data reconstruction:** On sweep speeds when less than 500 points are acquired across the screen, a built-in digital filter will automatically reconstruct the data in the real-time acquisition modes (single-shot acquisition). The filter "off" position in the display mode will display raw data.

**Display colors:** A default color selection is set up. Different colors are used for display background, channels, functions, background text, highlighted text, advisories, markers, overlapping waveforms, and memories. If desired, colors may be changed either from the front panel or over HP-IB.

**HP-IB** **Data transfer rate:** 80k bytes/s

---

## MEASUREMENT AIDS

**Markers:** dual voltage markers and dual time markers are available. Voltage markers can be assigned to channels, memories, or functions.

**Automatic Edge Finders:** the time markers can be assigned automatically to any displayed edge of either polarity on any channel. The voltage markers establish the threshold reference for the time markers in this mode.

**Automatic Pulse Parameter Measurements:** the following pulse parameter measurements are performed automatically (as defined by IEEE standard 194-1977, "IEEE Standard Pulse Terms and Definitions").

Frequency	Overshoot
Period	Peak-to-peak voltage
Duty cycle	Average voltage
Positive pulse width	RMS voltage
Negative pulse width	Top voltage*
Rise time	Base voltage*
Fall time	Maximum voltage
Preshoot	Minimum voltage

**Waveform Math:** two independent functions are provided for waveform math. The operations are +, -, and invert. The vertical channels or any of the waveform memories can be used as operands for the waveform math.

\* only available over the HP-IB.

---

## SETUP AIDS

**Presets:** vertical deflection factor, offset, and trigger level can be preset independently on each channel for ECL and TTL levels.

**Auto-Scale:** pressing the Auto-Scale button causes the vertical and horizontal deflection factors and the trigger source to be set for a display appropriate to the signals applied to the inputs. Requires a duty cycle greater than 0.1% and frequency greater than 50 Hz. Operative only for relatively stable input signals.

**Save/Recall:** ten front panel setups may be saved in non-volatile memory. If Auto-Scale is inadvertently pressed, pressing Recall followed by Auto-Scale, restores the instrument to the state prior to the last Auto-Scale.



---

## General Characteristics

### ENVIRONMENTAL CONDITIONS

#### Temperature

**Operating:** +15°C to + 55° C (+59° F to + 131° F)

**Non-operating:** -40° C to +75° C (-40° F to +167° F)

#### Humidity

**Operating:** up to 95% relative humidity (non-condensing) at  
+40° C (+104° F)

**Non-operating:** up to 90% relative humidity at +65° C  
(+149° F).

#### Altitude

**Operating:** up to 4600 metres (15 000 ft)

**Non-operating:** up to 15 300 metres (50 000 ft).

**Vibration:** vibrated in three orthogonal axes for 15 minutes  
each axis; 0.38mm (0.015 in) peak-to-peak excursion; 5  
to 55 Hz; 1 minute/octave sweep.

---

### POWER REQUIREMENTS

**Voltage:** 115/230 V ac, -25% to + 15%, 48-66 Hz.

**Power:** 350 watts maximum, 700 VA maximum.

---

### WEIGHT

**Net:** approximately 27 kg ( 59 lb).

**Shipping:** approximately 32 kg ( 70 lb).

## DIMENSIONS

Refer to outline drawings below.

*Notes:*

- 1. Dimensions are for general information only. If dimensions are required for building special enclosures, contact your HP field engineer*
- 2. Dimensions are in millimetres and (inches).*

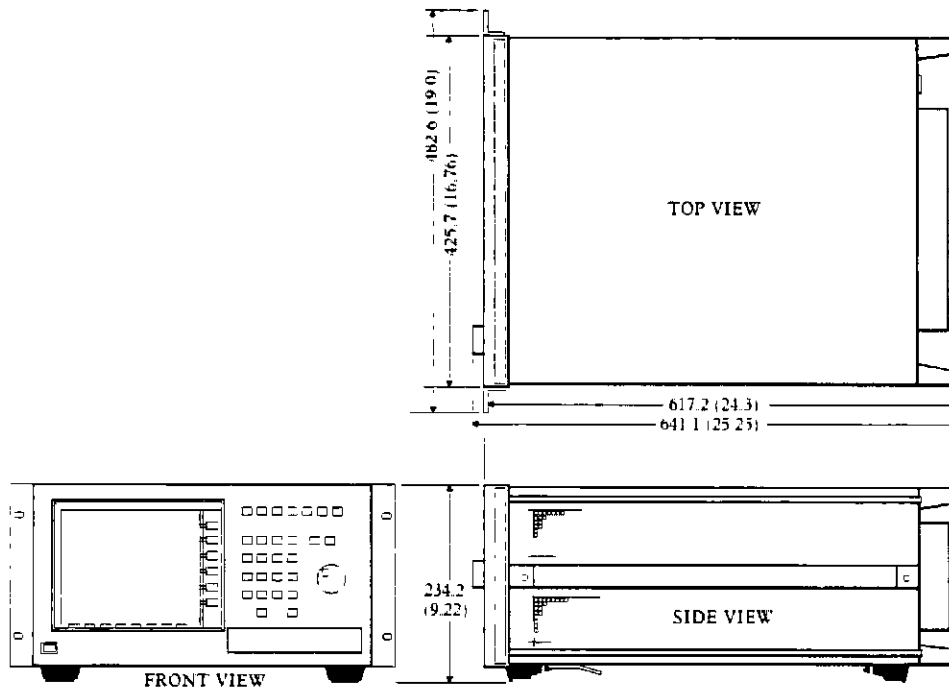

# A

## INCREASING VERTICAL RESOLUTION

---

Evaluation of an A/D converter's system resolution should never be limited to its rated number of bits. Rather, a system's vertical resolution should be evaluated in terms of its signal-to-noise ratio or effective bits. Effective bits is a means of specifying a system's vertical performance as compared to a perfect A/D (i.e., a perfectly linear and distortionless A/D). The family of curves in figure A-1 (page A-3) plot an A/D's system resolution in effective bits as a function of input and amplifier signal-to-noise ratio and the converter's number of bits. Effective bits may also be computed using the sine wave curve fit test and the following formula:

$$\text{effective bits} = N - \log_2 \frac{\text{rms error (actual)}}{\text{rms error (ideal)}}$$

The rms error (actual) is the error measured relative to the best fit perfect sine wave. The rms error (ideal) is the theoretical error from a perfect N-bit converter. See Product Note 5180A-2 (HP part no. 5952-7629) for details.

A microprocessor-based digital architecture oscilloscope allows use of internal software routines to perform digital filtering that can improve vertical resolution. These filters allow more precise waveform reconstruction by trading bandwidth for resolution.

In an ideal system (with no noise), digital filtering cannot improve vertical resolution. However, all systems have inherent noise above dc. The quantization process by itself generally appears as white noise to the Nyquist frequency. This may or may not be the dominant source of noise. However, other noise sources contribute to the total noise in any real system. If this total noise is white in composition, effective resolution can actually be improved beyond the A/D's ideal performance with digital filtering. What separates the HP 54111D from other digitizing oscilloscopes is that this instrument not only uses digital filtering, but it also employs a vertical dithering scheme to ensure that the total noise is white in composition for the full frequency spectrum of the instrument, including dc.

The dithering scheme is achieved by staggering the references of the four-phase A/D converters. Each A/D is vertically referenced 1/4 LSB apart. Even though a conventional six-bit converter results in only 64 unique quantization levels, the HP 54111D's four-phased converters have 256 unique quantization levels; the same number of unique levels found in an eight-bit converter.

The four staggered A/Ds appear as one A/D with high frequency noise injected. As with any linear system having noise content that is white in composition, the rms noise voltage is proportional to the square root of the system bandwidth. By limiting the system bandwidth to 1/4 the Nyquist frequency with digital filtering, the system (including the  $\pm 1/2$  LSB quantization error) can be reduced by a factor of two. Provided the signal content is within the bandpass of the filter, the signal-to-noise ratio is the same as that generated by an  $n+1$  bit A/D converter. This is analogous to filtering with an analog low pass filter. However with digital filtering, not only is system noise reduced, but the quantization error is reduced as well, hence improving vertical resolution. Another effective bit will be gained by lowering the bandwidth by another factor of four.

### Effective Bits vs Input Noise for Ideal A to D Converters

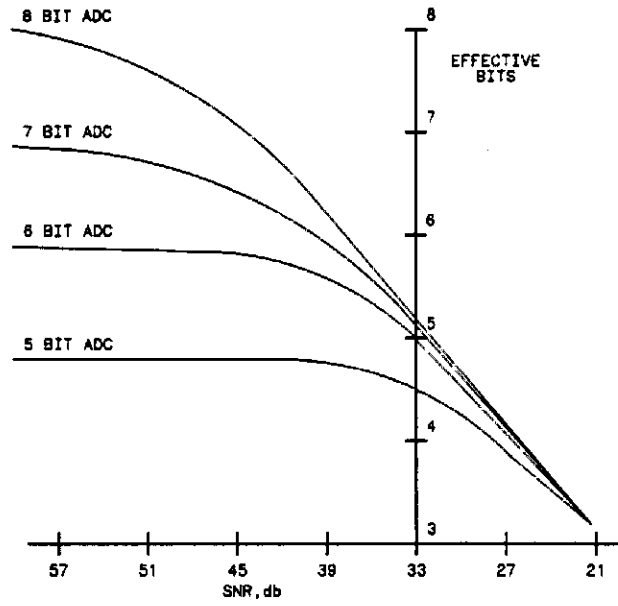

54111/RL28

Figure A-1. Effective Bits Vs. Input Noise for Ideal A/D Converter.

# B

## INSIDE THE HP 54111D

---



### Hybrid Approach Overcomes Technology Barriers

Different IC technologies have distinct advantages and disadvantages. Often, when pushing performance limits beyond the capability of any one technology, combining ICs from different processes achieves synergy, permitting optimum performance from each technology. To develop a digitizing oscilloscope with a maximum sampling rate of 1 gigasample/second required the capability of GaAs and silicon. HP chose a hybrid solution to solve the problem with today's advanced integrated circuit processes.

The hybrid approach takes greatest advantage of the strength of each process. GaAs ICs with MESFET (metal semiconductor FET) transistors and companion GaAs Schottky diodes are ideally suited for implementing a high speed track-and-hold function. On the other hand, high-speed silicon bipolar offers higher resolution for flash converters operating beyond 100 megasamples/second. High-speed memory requirements are still best handled by MOS processes due to VLSI capability at minimum power levels. The HP 54111D data acquisition system fully utilizes all of these technologies using a hybrid approach.

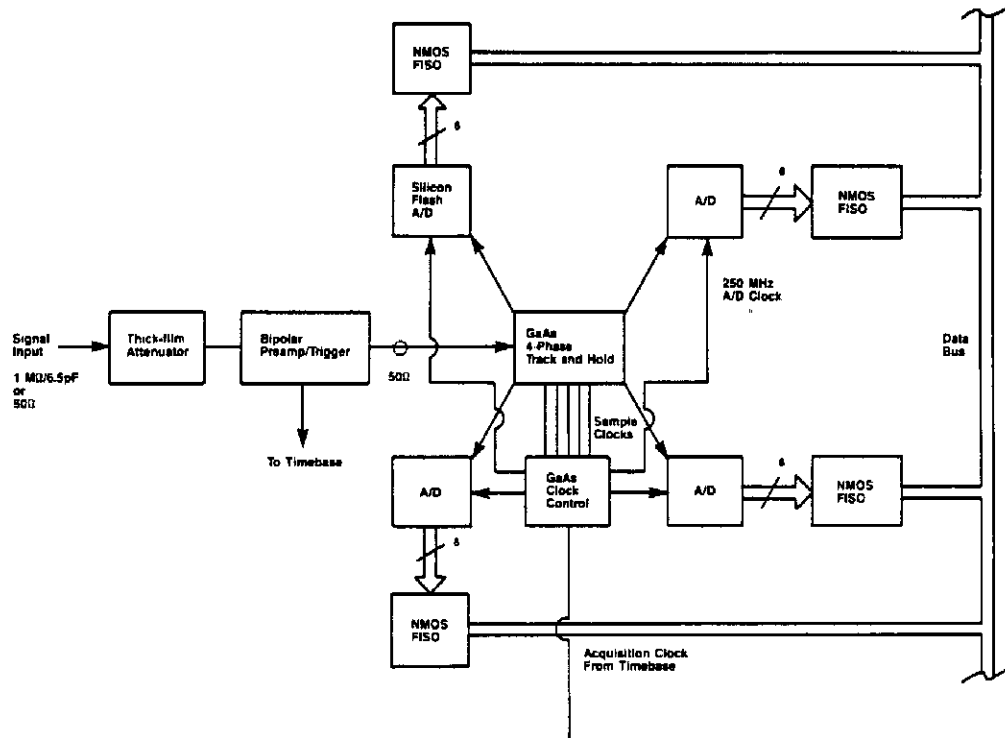

Figure B-1. HP 54111D Signal Acquisition.

---

**Front End  
Technology Offers  
Performance and  
Versatility**

For general purpose applications, a general-purpose front end is needed to handle a wide range of input signals. Attenuation provided by the attenuator and preamp hybrids allows control of vertical sensitivities from 1 mV/div to 5 V/div with continuous ranging.

The input thick-film hybrid provides electromechanical selection of three decades of attenuation at 1 M $\Omega$  input impedance. Miniaturization of the contact system and hybrid layout allow a nominal input capacitance of 6.5 pF. A 50  $\Omega$  termination is selectable on the hybrid for transmission-line applications. The thick-film attenuation drives a preamp/trigger hybrid, whose primary component is a custom bipolar IC chip that provides additional attenuation control and trigger signal generation.

---

**GaAs Track and  
Hold Circuits for  
Silicon Converters**

The track-and-hold embodies a four-phase, two rank sampling technique that allows the input signal to be sampled in the first rank at 1 gigasample/second and fanned out in the second rank as four sampled analog outputs, each shifted in phase by 1 ns and clocking at 250 megasamples per second. This analog data deceleration allows four silicon 6 bit flash converters to digitize each of the four sampled outputs at 250 megasamples/second. When reassembled, data from the four A/Ds is equivalent to that of one A/D clocking at 1 gigasample/second.

---

**Deeper Memory  
with Another  
Internal HP  
Process**

For a digitizing oscilloscope, the waveform memory must be capable of fast write cycles. Although static ECL RAM can take data from each A/D at 250 megasamples/second, power constraints prevent its use. A high-speed, fast-in-slow-out (FISO) VLSI memory chip was developed by Hewlett-Packard and fabricated in a 1.7 micron gate NMOS process. The design is capable of input data rates exceeding 250 megasamples/second with a memory depth of 2k bytes. Using one of these memory chips per A/D gives a total memory depth of 8k bytes per channel, allowing an 8  $\mu$ s waveform record at the full 1 gigasample/second sampling rate.



# C

## Automatic Parametric Measurements

---

### Introduction

One of the HP 54111D's primary features is its ability to make parametric measurements on displayed waveforms. This chapter provides details on how automatic measurements are performed and some tips on how to improve automatic measurement results.

### Measurement Setup

Measurements typically should be made at the fastest possible sweep speed to obtain the most measurement accuracy possible. For any measurement to be made, the portion of the waveform required for that measurement must be displayed on the oscilloscope. That is:

- period or frequency measurement — at least one complete cycle must be displayed.
- pulse width measurement — the entire pulse must be displayed.
- risetime measurement — the leading (positive-going) edge of the waveform must be displayed.
- falltime measurement — the trailing (negative-going) edge of the waveform must be displayed.

### Making Measurements

If more than one waveform, edge, or pulse is displayed, the measurements are made on the first (leftmost) portion of the displayed waveform that can be used.

When any of the defined measurements are requested, the oscilloscope first determines the top (100%) and base (0%) voltages of the waveform. From this information, it can determine the other important voltage values (10% voltage, 90% voltage, and 50% voltage) required to make the measurements. The 10% and 90% voltage values are used in the risetime and falltime measurements. The 50% voltage value is used for measuring frequency, period, pulse width, and duty cycle.

### Automatic TOP-BASE

TOP-BASE is the heart of most automatic parametric measurements. It is used to find VTOP and VBASE, the 0% and 100% voltage levels at the top and the bottom of the waveform. From this information the instrument can determine the 10, 50, and 90 percent points, which are used in most automatic measurements. The TOP or BASE of the waveform is not necessarily the maximum or minimum voltage present on the waveform. Consider a pulse that has a slight amount of overshoot. It would be wrong to select the highest peak of

the waveform as the TOP since the waveform normally rests below the perturbation.

TOP-BASE performs a histogram on the waveform and finds the most prevalent point above and below the waveform midpoint. The most prevalent point is one that represents greater than approximately 5% of the total display points (501) and is considered to be either the TOP or BASE. If no point accounts for more than 5% of the total, then the TOP is chosen as the absolute maximum and the BASE is chosen as the absolute minimum.

---

## Measurement Algorithms

**Frequency** The frequency of the first complete cycle on screen is measured using the 50% levels. The algorithm used is:

```
if the first edge on screen is rising
then
    frequency = 1/(time at second rising edge
                  - time at first rising edge)
else
    frequency = 1/(time at second falling edge
                  - time at first falling edge)
```

**Period** The period is measured at the 50% voltage level of the waveform. The algorithm for this measurement is:

```
if the first edge on screen is rising
then
    period = (time at second rising edge
             - time at first rising edge)
else
    period = (time at second falling edge
             - time at first falling edge)
```

**Duty Cycle** The positive pulse width and the period of the displayed signal are measured. Then the duty cycle is calculated using the following formula:

$$\text{duty cycle} = (\text{+pulse width/period}) \times 100$$

**Positive Pulse width (+ Width)** Pulse width is measured at the 50% voltage level. The algorithm for this measurement is:

```
if the first edge on screen is falling
then
width = (time at second falling edge
         - time at first rising edge)
else
width = (time at first falling edge
         - time at first rising edge)
```

**Negative Pulse Width (- Width)** Negative pulse width is the width of the first negative pulse on screen using the 50% levels. The algorithm used is:

```
if the first edge on screen is rising
then
width = (time at second rising edge
         - time at first falling edge)
else
width = (time at first rising edge)
         - time at first falling edge)
```

**Risetime** The risetime of the first displayed rising (positive-going) edge is measured. To obtain the best possible measurement accuracy, set the sweep speed as fast as possible while leaving the leading edge of the waveform on the display. The risetime is determined by measuring the time at the 10% and 90% voltage points on the rising edge, and then the risetime is calculated using the formula:

$$\text{risetime} = (\text{time at 90\% point} - \text{time at 10\% point})$$

**Falltime** Falltime is measured between the 10% and 90% points of the falling (negative-going) edge. To obtain the best possible measurement accuracy, set the sweep speed as fast as possible while leaving the falling edge of the waveform on the display. The falltime is calculated using the following formula:

$$\text{falltime} = (\text{time at 10\% point} - \text{time at 90\% point})$$

**Peak-to-Peak Voltage** The maximum and minimum voltages for the selected source are measured. Then the peak-to-peak voltage is calculated using the formula:

$$\text{peak-to-peak voltage} = V_{\text{max}} - V_{\text{min}}$$

where  $V_{max}$  and  $V_{min}$  are the maximum and minimum voltages present on the selected source.

**RMS Voltage** The rms voltage is computed over one complete period with the following equation:

$$V_{rms} = \left[ \frac{1}{n} \sum_{j=1}^{j=n} V_j^2 \right]^{1/2}$$

**Average Voltage** The average voltage of the first cycle of the displayed signal is measured. If a complete cycle is not present, the instrument will average the data points on screen.

**Preshoot** Preshoot measures the first edge on screen using the following algorithm:

```
if the first edge on screen is rising
then
    preshoot = Vbase - Vmin
else
    preshoot = Vmax - Vtop
```

Note that preshoot is measured on the top of a waveform if the first edge on screen is a falling edge. Also,  $V_{max}$ ,  $V_{top}$ ,  $V_{base}$ , and  $V_{min}$  are measured using all the data on screen.

**Overshoot** Overshoot measures the first edge on screen using the following algorithm:

```
if the first edge on screen is rising
then
    overshoot = Vmax - Vtop
else
    overshoot = Vbase - Vmin
```

Note that overshoot is measured on the base of a waveform if the first edge on screen is a falling edge. Also,  $V_{max}$ ,  $V_{top}$ ,  $V_{base}$ , and  $V_{min}$  are measured using all the data on screen.

## Index

---

### A

Abort key (Hardcopy menu) 13-3, 13-6  
accessories, list of 2-4  
acquisition, data 3-2...3-3, 4-2, 5-2, 7-6...7-7,  
7-11...7-16, 13-3, B-1...B-2  
A/D (ADC) reference calibration 5-6...5-7,  
14-6...14-9  
Add to Memory key (Waveform Save menu)  
10-3  
Addition, waveform 11-1, 11-3  
After Pos/Neg Edge key (trigger, event) 6-24  
algorithms, measurements C-2...C-4  
alignment, time 14-14  
All key (Measure menu) 12-3  
altitude, operating 2-1  
attenuation (trigger input) 6-3  
attenuation ratio (Probe/Utility menu)  
14-2...14-3  
Auto Level Set key (Delta V menu) 8-4  
Auto Mode (ADC Ref Cal) 14-7  
Auto Pen key (Hardcopy menu) 13-5  
Auto/Trg'd Sweep key 5-6...5-7, 7-8  
automatic measurements 10-4, 12-1...12-3,  
C-1...C-4  
AUTOSCALE 3-5...3-6, 5-1  
average voltage measurement 12-3, C-4  
averaging 3-3, 7-7, 7-11, 13-4

### B

background adjustment 3-8  
bandwidth, versus filtering 7-1  
bandwidth limit 7-6  
baseline 5-6  
basic setup 2-1  
brightness adjustment 3-8

### C

Cal Menu 14-1, 14-5...14-19  
calibration 5-6...5-7  
calibration factors 14-6  
channel 1/2 menus 4-1...4-3  
Channel Skew Cal 14-6, 14-13, 14-15...14-17  
CLEAR key (ENTER column) 3-5  
CLEAR DISPLAY key 3-2...3-3, 6-27, 7-8,  
7-11...7-12, 7-15  
Clear Memory key (Waveform Save menu)  
10-3  
color display, default 2-4, 8-3, 14-21...14-22  
Color Menu 14-1, 14-20...14-22  
coupling, input 4-3, 6-3...6-5  
CRT Menu 14-1

### D

data acquisition 3-2...3-3, 5-2, 7-6...7-7,  
7-11...7-16  
data filters 7-1, 7-6...7-7, 7-12, 7-16  
dc offset 4-2  
decrement key 3-7  
default color display 8-3, 9-2  
Default Scaling 11-4  
DELAY key 3-3, 5-3...5-4, 5-6, 6-5, 7-3,  
7-5...7-6, 7-13, 7-17...7-18, 10-5  
delay reference 5-3  
Delay Reference key 5-4, 7-5  
DELAY...THEN key (trigger, time) 6-20  
Delta t menu 8-1, 9-1...9-6  
Delta V menu 8-1...8-6, 9-1...9-2  
digitizing rate 7-11, 7-15  
display, color 2-4, 14-20...14-22  
Display key (Waveform Math menu) 11-2  
Display key (Waveform Save menu) 10-4  
Display menu 7-1...7-18, 8-3  
Display On/Off key 4-2

display, persistence 7-7  
dithering scheme A-2  
dual area display 7-8, 10-4  
duty cycle measurement 12-3, C-2

## E

ECL preset 4-3  
Edge Find key (Delta t menu) 9-3  
edge trigger mode 6-3...6-6  
effective bits 7-1, 7-6...7-7, A-1...A-3  
ENTER column 3-7  
entry devices 3-7  
EOI (end or identify) key (HP-IB/Utility menu) 14-4  
exercises  
    event delay trigger 6-25...6-27  
    pattern trigger 6-8...6-15  
    state trigger 6-17...6-19  
    time interval measurement 9-4...9-6  
    time delay 6-21...6-23  
    waveform math 11-3...11-5  
environment, operating 2-1  
event delay trigger exercise 6-25...6-27  
event trigger mode 6-23...6-27

## F

fall time measurement 12-3, C-3  
feature set 1-1  
filters 7-1, 7-6...7-7, 7-12, 7-16, A-1...A-3  
Form Feed key (Hardcopy menu) 13-3  
frequency measurement 12-3, C-2  
front-panel overview 1-3, 2-3, 3-1  
Function key (Waveform Math menu) 11-2

## G

GaAs ICs B-1...B-3  
glitch detection 7-9  
graticule, selection 7-1, 7-8...7-9

## H

Hardcopy menu 12-1, 13-1...13-1, 13-2  
Hardcopy Device 13-2, 13-3  
HOLDOFF, events 6-3...6-6, 6-8  
HOLDOFF, time 6-5...6-6, 6-8  
horizontal operation 5-1...5-7  
HP-IB ADDRESS key (HP-IB/Utility menu) 14-4  
HP-IB Menu 14-1, 14-4...14-14-5  
HUE key (Color/Utility menu) 14-20, 14-22  
humidity, operating 2-1  
hysteresis, calibration of 14-12...14-13

## I

increment key 3-7  
infinite persistence 7-7...7-8  
Input Coupling key 4-3  
input impedance 6-3...6-5, 10-11  
input selection 3-9  
instrument status 5-6  
Intergrate (Waveform Math) 11-1, 11-5, 11-7  
Is/Is Not Present (trigger, state) key 6-15  
inverting waveforms 11-1, 11-6

## K

knob 3-7

## L

Listen Only mode 13-2, 14-4  
LOCAL key 3-6  
local lockout 3-6  
logic family presets 4-1, 4-3  
logic family triggering 6-1  
LUMINOSITY key (Color/Utility menu)  
14-20...14-22

## M

manual contents 1-2, 2-4  
Manual Mode (ADC Ref Cal) 14-7...14-9  
markers, voltage 8-1...8-3  
math functions 11-1...11-5  
Maximum (Waveform Math) 11-1, 11-6  
Measure menu 10-4, 12-1...12-3  
measurement algorithms C-2...C-4  
memories, long waveform 10-1...10-2, 10-4,  
11-2  
memories, pixel 10-1...10-2  
memories, short waveform 10-1...10-2, 10-4,  
11-3  
memory bar 5-4...5-5, 7-3...7-6  
memory depth (real time) 5-3, 7-3, 10-1, B-3  
memory type versus display mode 10-2  
menus 3-2, 3-8...3-9  
Minimum (Waveform Math) 11-1, 11-6  
More key 3-8, 12-1  
Multiply (Waveform Math) 11-1, 11-5, 11-7

## N

Neg/Pos key (trigger, edge) 6-3  
negative pulse width measurement 12-3, C-3  
negative time 5-3...5-4, 7-5  
noise, reducing display 7-7, A-1...A-3  
Nyquist frequency A-1...A-2

## O

Of Pos/Neg Edge key (trigger, events) 6-25  
Offset key 4-2, 11-3, 11-4  
one-key down power up 14-19  
only 11-1, 11-6  
operand 11-1  
operating environment 2-1  
overshoot measurement 12-3, C-4

## P

pan feature 3-3, 5-3, 7-1, 7-13...7-18  
PaintJet (Printer) 13-3, 13-4  
parametric, automatic measurements  
12-1...12-3  
PATTERN (trigger, state) key 6-15  
pattern trigger mode 6-6...6-15  
pattern trigger exercise 6-9...6-15  
Pattern When Entered 6-7, 6-11  
Pattern When Exited 6-7, 6-13  
Pattern Present > 6-8, 6-13...6-14  
Pattern Present < 6-8, 6-14  
pattern, time-qualified 6-13...6-15  
Pause/Continue key (Hardcopy menu) 13-3,  
13-6  
peak-to-peak voltage measurement 12-3, C-3  
Pen Speed key (Hardcopy menu) 13-5  
period measurement 12-3, C-2  
persistence 7-7...7-8, 13-4  
pixel memories 8-2, 10-1...10-4  
Plot All Key 13-6  
Plot Display key (Hardcopy menu) 13-3  
Plot Factors key (Hardcopy menu) 13-4  
Plot Graticule key (Hardcopy menu) 13-4  
Plotter Menu 13-2, 13-5  
Plus (Waveform Math) 11-1, 11-6  
plotting 13-1...13-4  
Pos/Neg key (trigger, edge) 6-3  
Pos/Neg key (trigger, time) 6-20  
positive pulse width measurement 12-3, C-3  
power cable 2-4  
power requirements 2-2  
pulse generators 14-15  
Preset key 4-3, 8-4

Preset Levels key (Delta V menu) 8-3...8-4  
preset levels, automatic 8-1  
preshoot measurement 12-3, C-4  
pre-trigger delay 5-3, 7-1, 7-5...7-6  
Print Display key (Hardcopy menu) 13-3  
Print Factors key (Hardcopy menu) 13-3  
Print Menu 13-2, 13-3  
printing 13-1...13-3  
Printer Type Key 13-3  
probe, HP 10033A 2-4, 14-2...14-3, 14-10  
Probe menu 14-1...14-4  
Probe Tip Cal 14-6, 14-9...14-11

## Q

quad area display 7-9, 10-4

## R

rack mount kit 2-4  
random repetitive sampling 7-2  
real-time mode 3-3, 4-2, 5-3...5-4, 7-1...7-3,  
7-6, 7-9, 7-12...7-13, 8-3, 10-3, 10-5, 11-2  
rear panel guide 2-3  
RECALL SETUP register 3-1, 3-4...3-5, 14-2  
reconstruction filter 7-12  
repetitive mode 3-3, 4-2, 5-4, 7-1...7-2, 7-6,  
7-9, 7-11...7-12, 8-3 10-3, 10-5, 11-1,  
11-3, 12-3, 13-4  
Resolution key 7-6...7-7, 7-12  
resolution, increasing vertical A-1...A-3  
Restore key (Waveform Save menu) 10-5  
return-to-local (RTL) message 3-6  
rise time measurement 12-3, C-3  
rms error (actual/ideal) A-1  
rms voltage measurement 12-3, C-4  
RUN key 3-2...3-3

## S

sample rate 5-2...5-3, 7-6

SATURATION key (Color/Utility menu)  
14-20...14-21  
SAVE SETUP register 3-1, 3-4...3-5, 14-2  
SCALING key (Waveform Save key) 10-5  
Screen key 7-8...7-9, 11-3, 11-4  
sensitivity control 4-2, 14-2  
single area display 7-8  
single-shot acquisition 7-2...7-3, 7-12...7-13  
single-shot exercise 7-9...7-12  
Slope key (trigger, edge) 6-5  
Source For Store key (Waveform Save menu)  
10-4...10-5  
source-to-source voltage measurement  
8-4...8-6  
START marker 9-2...9-4  
Start Plot 13-6  
Start Print Key 13-3  
Start/Stop On Edge key (Delta t menu) 9-2  
state trigger mode 6-15...6-19  
state trigger exercise 6-17...6-19  
STATUS line 5-6  
step key 3-7  
STOP marker 9-2...9-4  
STOP/SINGLE key 3-2...3-3, 7-3, 7-9...7-12,  
7-15  
Store key (Waveform Save menu) 10-5  
stored waveforms 3-2  
subtraction, waveform 11-1, 11-6  
sweep speed 5-2...5-3, 7-6, 7-12  
system control section 3-1

## T

Talk/Listen mode 13-2, 14-4  
Talk Only mode 13-2, 14-4  
technology of HP 54111D B-1...B-3  
temperature, operating 2-1  
temperature, drift 5-7  
Test Menu 14-1  
throughput 4-2  
time delay trigger exercise 6-21  
TIME/DIV key 3-3, 3-6, 5-2, 5-6, 6-6,  
7-12...7-13, 7-15...7-18, 10-5  
time-interval measurement exercise 9-4...9-6  
time markers 9-1...



- time-qualified pattern 6-13...6-15
- Time Scaling 11-4
- time trigger 6-19...6-23
- Timebase Cal 14-6, 14-13...14-19
- Timebase Frequency Cal 14-6, 14-17...14-19
- Timebase menu 3-3, 3-6, 5-1, 6-3, 6-6, 7-3
- TOP – BASE C-1
- traceability 14-4, 14-6, 14-17...14-18
- TRIG ON N EVENTS key (trigger, events) 6-25
- Trig On PATTERN key 6-7
- Trig On Pos/Neg Edge key (trigger, state) 6-15
- Trig On Pos/Neg Edge key (trigger, time) 6-20
- Trig Src (trigger source) key 6-3...6-4
- Trigger Cal 14-6, 14-12
- trigger levels, calibration of 14-12...14-13
- TRIGGER LEVEL key 6-3...6-4, 6-7
- Trigger menu 6-1...6-27
  - edge mode 6-3...6-6
  - event mode 6-23...6-27
  - pattern mode 6-6...6-15
  - state mode 6-15...6-19
  - time mode 6-19...6-23
- trigger (pre/post) delay 5-3, 7-1, 7-5...7-6, 7-17...7-18
- trigger sensitivity, calibration of 14-12...14-13
- trigger source 6-3...6-5
- triggered sweep 5-6, 6-5, 7-8
- TTL preset 4-3
- two-key down power up 14-19

## U

- Utility menu 13-2, 14-1...14-22

## V

- VARIABLE LEVELS key (Delta V menu) 8-4
- Versus 11-1, 11-6
- Vertical Cal 14-6, 14-11...14-12

- vertical operation 4-1, 8-3
- vertical resolution, increasing A-1...A-3
- vertical scaling 7-9
- Vertical Scaling Units 11-5
- volatile memories 10-1
- voltage markers 8-1...8-6
- Volts/Div key 4-2

## W

- waveform expansion/compression (zooming) 7-13
- Waveform Math menu 8-3, 11-1...11-5
- waveform memories 7-3, 7-7...7-8, 8-2, 10-1...10-5, 11-1
- WAVEFORM/PIXEL MEMORY key (Waveform Save menu) 10-3
- waveform record (8k) 7-15...7-16
- Waveform Save menu 8-3, 10-1...10-5

## Z

- zoom feature 3-3, 7-1, 7-13...7-18