



XLCT® Hydraulic Torque Wrench

The XLCT is the world's best-selling limited clearance industrial bolting system with over one hundred thousand in use around the world. Since 1992, the signature red housing has represented quality, durability and reliability on job sites in every major industry. From the tallest roller coasters to the world's largest bridges, the XLCT has the power to get the job done.

LOCK-UP RELEASE



Like the MXT, the XLCT features a release lever that allows you to release the tool after torquing for easy removal. (Also found on the STEALTH).

ZERO-SLIP RATCHET



The XLCT series features a Zero-Slip ratchet for more powerful breakout and faster tightening. The secondary pawl inside the tool prevents the ratchet from turning opposite of the direction it is being driven.

MULTI-USE ACCESSORIES



The XLCT is available with interchangeable cartridges for 6-point hex, 12-point hex, allen drives, square drives, open spanners, and many other configurations to simplify the most challenging bolting jobs.

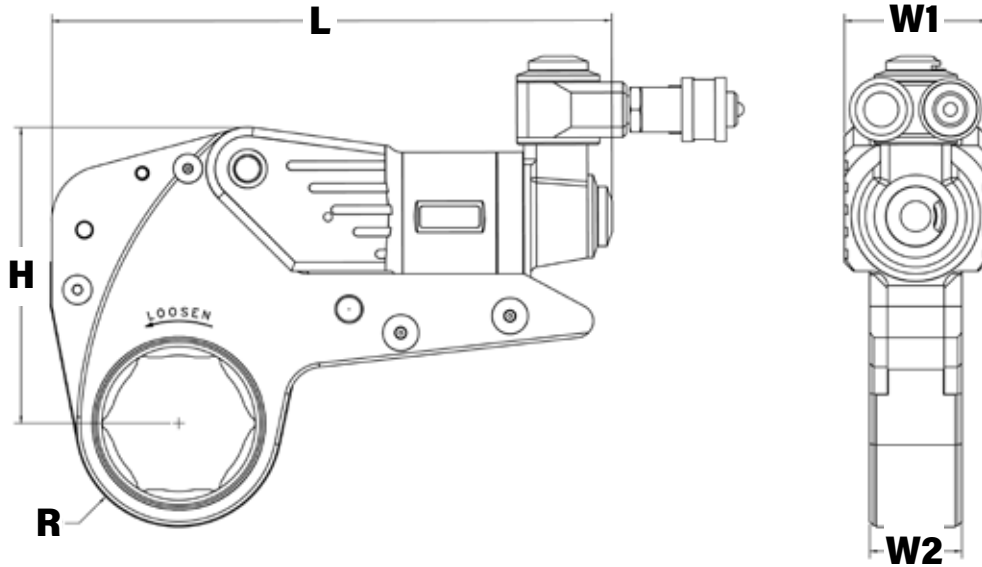

LEGEND: H = HEIGHT W1 = WIDTH OF POWERHEAD W2 = WIDTH OF LINK L = LENGTH R = RADIUS

MODEL NUMBER	H	W1	W2	L	R		WEIGHT	TORQUE	
IMPERIAL	in.				in. (Min)	in. (Max)	lbs.	ft-lbs (Min)	ft-lbs (Max)
XLCT - 2	4.02	1.94	1.25	7.33	1.03	1.76	2.05	243	1,687
XLCT - 4	5.36	2.58	1.67	10.19	1.33	2.32	4.25	580	3,855
XLCT - 8	6.70	3.23	2.09	12.29	1.77	2.89	7.15	1,143	8,151
XLCT - 14	8.04	3.88	2.50	14.61	2.32	3.47	11.30	2,010	13,400
XLCT - 18	9.08	4.38	2.83	14.34	2.62	3.87	14.85	2,790	19,100
XLCT - 30	10.71	5.17	3.35	16.82	3.07	4.80	23.80	4,579	30,986
XLCT - 45	13.39	6.00	3.94	21.10	4.05	4.88	43.00	7,130	49,180
XLCT - 60	13.39	6.46	4.16	20.70	4.81	5.03	48.00	8,867	59,110
METRIC	mm				mm (Min)	mm (Max)	kg	Nm (Min)	Nm (Max)
XLCT - 2	102	49	32	186	26	44.70	0.93	329	2286
XLCT - 4	136	66	42	259	34	58.93	1.93	786	5224
XLCT - 8	170	82	53	312	45	73.41	3.25	1549	11045
XLCT - 14	204	99	64	371	59	88.14	5.14	2724	18157
XLCT - 18	231	111	72	364	67	98.30	6.75	3780	25881
XLCT - 30	272	131	85	427	78	121.92	10.82	6205	41986
XLCT - 45	340	152	100	536	103	124.00	19.50	9667	66679
XLCT - 60	340	164	106	526	122	128.00	21.80	12022	80143

The World's Most Trusted Industrial Bolting Systems



Headquarters:
333 Route 17 N., Mahwah, NJ 07430
+1-201-512-9500

Email:
info@hytorc.com

Phone:
1-800-FOR-HYTORC

Online:
hytorc.com