



Visit us at Transcat.com 

sales@transcat.com 1.800.828.1470

FLUKE®

Calibration

9118A

Calibration Furnace

Users Manual

September 2012 Rev. 1, 2/2014

© 2012-2014 Fluke Corporation. All rights reserved. Specifications are subject to change without notice.

All product names are trademarks of their respective companies.

LIMITED WARRANTY AND LIMITATION OF LIABILITY

This Fluke product will be free from defects in material and workmanship for one year from the date of purchase. This warranty does not cover fuses, disposable batteries, or damage from accident, neglect, misuse, alteration, contamination, or abnormal conditions of operation or handling. Resellers are not authorized to extend any other warranty on Fluke's behalf. To obtain service during the warranty period, contact your nearest Fluke authorized service center to obtain return authorization information, then send the product to that Service Center with a description of the problem.

THIS WARRANTY IS YOUR ONLY REMEDY. NO OTHER WARRANTIES, SUCH AS FITNESS FOR A PARTICULAR PURPOSE, ARE EXPRESSED OR IMPLIED. FLUKE IS NOT LIABLE FOR ANY SPECIAL, INDIRECT, INCIDENTAL OR CONSEQUENTIAL DAMAGES OR LOSSES, ARISING FROM ANY CAUSE OR THEORY. Since some states or countries do not allow the exclusion or limitation of an implied warranty or of incidental or consequential damages, this limitation of liability may not apply to you.

Fluke Corporation
P.O. Box 9090
Everett, WA 98206-9090
U.S.A.

Fluke Europe B.V.
P.O. Box 1186
5602 BD Eindhoven
The Netherlands

Table of Contents

Title	Page
Introduction	1
How to Contact Fluke	1
Safety Information.....	1
Installation	6
Unpack and Inspection	6
Placement.....	6
Dry-Out Period	6
How to Move the Product.....	7
Product Components	7
Front-Panel Controls.....	10
Rear-Panel Connections.....	12
Probe Installation	17
The Isothermal Block	20
Connect to Mains Power	21
How to Turn On the Product	21
How to Turn Off the Product	22
Display.....	23
Setup	23
Set the Language.....	23
Set Display Contrast	23

Operation	24
How to Set Parameters in the Product	25
Value List	25
Set Number Value	25
Softkey Menus	26
Temperature (TEMP) Setup Menu	29
Scan Rate	29
Cutout.....	29
Program (PROG) Menu	29
RAMP/SOAK Menu	29
RUN PROG Function	30
Calibration (CALIB) Menu	30
Calibration (CAL) Points Menu	30
PID Setup Menu	31
Furnace Setup Menu.....	31
System Menu	31
Display (DISP) Menu.....	31
Communications (COMM) Setup Menu.....	31
Password Setup Menu	32
System Information (INFO) Menu.....	32
Adjust Furnace Temperature	32
Set the Furnace Temperature with a Preset.....	32
Set the Furnace Temperature Manually	33
How to Stop the Furnace Heat Cycle	33
Change a Preset Temperature.....	33
Probe Insertion	34
Cutouts	34
Soft Cutout	34
Hard Cutout.....	35
Chassis Thermostat Cutout.....	35
Fan Fault Cutout	35
TC or Heater Fault Cutout	35
Remote Operation	35
Digital Communication Interface	36

How to Configure the Digital Interface	37
Input Terminators	37
SCPI Commands	37
Commands by Function or Group	37
Alphabetic List of Commands	42
Maintenance	59
Cutout Test	60
How to Clean the Product	60
Furnace Calibration	60
Calibration Terminology	61
Environment Conditions	61
Calibration Equipment	61
Calibration	61
Calibration Procedure for Tube Furnace	64
Calibration procedure for 9118A-ITB (with Isothermal Block)	70
Calibration Equipment Setup	70
Stability Test	73
Accuracy Test	73
Accuracy Adjustment	74
Axial Uniformity	74
Specifications for 9118A and 9118A-ITB	78
General Specifications	78
Accuracy Specifications	79
Radial Uniformity	79
Axial Uniformity	79
Temperature Stability	79
Heating Time (23 °C to 1200 °C)	80
Cooling Time (1200 °C to 300 °C)	80

List of Tables

Table	Title	Page
1.	Symbols	5
2.	Front-Panel Controls	11
3.	Rear-Panel Connections	13
4.	Display Elements	23
5.	Commands by Function or Group	38
6.	Calibration Equipment	61
7.	Furnace Calibration Tests and Adjustments	63
8.	Stability Test Data	66
9.	Axial Uniformity Test	67
10.	Skew Correction Values	67
11.	SKEW Parameter	67
12.	Zone Correction Values	68
13.	ZONE Parameter	68
14.	Accuracy Parameter	69
15.	Stability Test Data with Isothermal Block	73
16.	Accuracy Parameter for Isothermal Block	74
17.	Axial Uniformity Test with Isothermal Block	75
18.	Skew Correction Values for Isothermal Block	76
19.	SKEW Parameter for Isothermal Block	76
20.	Zone Correction Values For Isothermal Block	77
21.	Zone Parameter for Isothermal Block	77

List of Figures

Figure	Title	Page
1.	Calibration Tube Furnace	8
2.	Front View with Isothermal Block	9
3.	Rear View with Isothermal Block	9
4.	Front-Panel Controls	10
5.	Rear-Panel Connections	12
6.	Rear View of 9118A Thermocouple Calibration Furnace with Isothermal Block	14
7.	Short Tube and Long Tube Insertion	15
8.	Rear Plug Insertion	15
9.	Attach the Rear Shield	16
10.	Attach the Support Bracket	16
11.	Front Plug Insertion	17
12.	Probe Installation A	18
13.	Probe Installation B	19
14.	Insert Alignment	20
15.	Power-Up Screen	21
16.	Main Screen	22
17.	Preset Selection	25
18.	SETPOINT Temperature	25
19.	Softkey Menu Tree	27
20.	Menu Softkey Displays	28

21.	Preset Selection.....	32
22.	Change Preset Temperature.....	33
23.	RS-232 Cable Connections.....	36
24.	Tube Furnace Calibration Flow Chart	62
25.	Test Equipment Connections	65
26.	Calibration Equipment Setup	71
27.	Calibration Procedure for Furnace with Thermo Block.....	72

Introduction

⚠⚠ Warning

To prevent possible electrical shock, fire, or personal injury, read all safety information before you use the Product.

The Product is used to calibrate Platinum Resistance Thermometers (PRTs), fiber optic sensors, and thermocouples to a maximum temperature of 1200 °C.

How to Contact Fluke

To contact Fluke Calibration, call one of these telephone numbers:

- Technical Support USA: 1-877-355-3225
- Calibration/Repair USA: 1-877-355-3225
- Canada: 1-800-36-FLUKE (1-800-363-5853)
- Europe: +31-40-2675-200
- Japan: +81-3-6714-3114
- Singapore: +65-6799-5566
- China: +86-400-810-3435
- Brazil: +55-11-3759-7600
- Anywhere in the world: +1-425-446-6110

To see product information and download the latest manual supplements, visit Fluke Calibration's website at www.flukecal.com.

To register your product, visit <http://flukecal.com/register-product>.

Safety Information

A **Warning** identifies conditions and procedures that are dangerous to the user. A **Caution** identifies conditions and procedures that can cause damage to the Product or the equipment under test.

⚠⚠ Warning

To prevent possible electrical shock, fire, or personal injury:

- **Read all safety information before you use the Product.**
- **Carefully read all instructions.**

- Use the Product only as specified, or the protection supplied by the Product can be compromised.
- Do not use the Product around explosive gas, vapor, or in damp or wet environments.
- Use this Product indoors only.
- Use only the mains power cord and connector approved for the voltage and plug configuration in your country and rated for the Product.
- Replace the mains power cord if the insulation is damaged or if the insulation shows signs of wear.
- Connect one end of the supplied ground wire to the protective earth ground terminal on the rear panel and the other end to an earth ground.
- Make sure the ground conductor in the mains power cord is connected to a protective earth ground. Disruption of the protective earth could put voltage on the chassis that could cause death.
- Do not put the Product where access to the mains power cord is blocked.
- Make sure that the Product is grounded before use.
- Do not use an extension cord or adapter plug.
- Do not use the Product if it operates incorrectly.
- Do not use the Product if it is damaged.
- Disable the Product if it is damaged.
- Make sure the power cord does not touch with hot parts of the Product.
- Make sure that the space around the Product meets minimum requirements.
- Do not keep the Product in operation and unattended at high temperatures.
- Use caution when you install and remove probes and inserts from the Product. They can be hot.
- Do not put the Product on a flammable surface and keep a fire extinguisher nearby.
- Do not set anything on top of the Product. Very high temperatures can cause the ignition of flammable materials.
- Do not remove the isothermal block and rear plug at high temperatures. The isothermal block and rear plug are the same temperature as shown on the display.
- Do not lift or move the Product with the isothermal block in place. The isothermal block and rear plug may fall out of the instrument.

- **Applicable personal protective equipment must be worn when you move hot temperature probes or do work near the furnace apertures.**
- **Do not use the Product for applications other than calibration work.**
- **The Product must only be used by approved personnel.**
- **Do not touch surfaces near the well access port. They can be very hot.**
- **Do not touch the insulation material in the Product. The insulation material can cause mild mechanical irritation with skin, eyes, and upper respiratory system. If it gets on your skin, flush area and wash gently. Do not rub or scratch exposed skin. If it gets into your eyes, flush abundantly with water. Do not rub eyes. If the nose and throat become irritated, move to a dust-free area and blow nose. If symptoms continue, get medical advice.**

⚠ Caution









To prevent damage to the Product:

- **Operate the Product at room temperature. See specifications.**
- **Keep a minimum of 45 cm clearance from the front, left, and right sides. Keep 150 cm from the top of the Product.**
- **Do not put the Product in a corner or cause a blockage behind the Product.**
- **Do not use fluids to clean out the well. Fluids in the Product can cause damage.**
- **Do not put unwanted material into the probe protection tube or hole of the insert. Fluids in the Product can cause damage.**
- **Only change calibration constant values from the factory set values when you calibrate the Product. These values are important in the safe operation of the Product.**
- **Read and understand the operation before you turn on the Product.**
- **Do not operate the Product in wet, oily, dusty, or dirty environments.**
- **Make sure the probe handle temperature does not go above its limit.**

- **Be careful with thermometer probes. Do not drop, stress, or let them become too hot.**
- **Do not operate the Product without the control probes correctly connected and put into the furnace. The furnace does not operate correctly without the control probes.**
- **Make sure the main probe and zone probe are connected to the correct connector.**
- **Turn off the furnace when a mains supply power fluctuation occurs. Turn on the furnace only when the mains power is stable.**
- **Make sure that all reference sensors used with the furnace are specified for the temperature range of the furnace.**
- **Do not disconnect the Product from the mains while the furnace temperature is above 80 °C.**
- **Do not attempt to push the block into the furnace. The isothermal block expands as the furnace heats due to thermal expansion. It will extend beyond the front of the furnace at high temperatures. This is normal.**
- **Remove the isothermal block and rear plug prior to transporting the furnace. The ceramic furnace tube is fragile and can be damaged by the block.**
- **To prevent the probe under test from getting stuck in the isothermal block due to different rates of thermal expansion, allow a clearance of at least 0.4 mm between the outer diameter of the probe and the hole of the isothermal block.**
- **Never introduce any foreign material into the probe hole of the isothermal block. Fluids, etc. can leak into the Product and cause damage.**
- **Minimize vibration in the calibration environment.**
- **The furnace can be used with or without an isothermal block installed. Unique calibration parameters are necessary for each mode of operation.**
- **Before operating the furnace, select the appropriate mode of operation in the calibration menu (see Furnace Setup Menu). If necessary, a calibration for the new mode of operation may be required.**

The symbols on the Product and in this manual are shown in Table 1.

Table 1. Symbols

Symbol	Description	Symbol	Description
	Risk of Danger. Important information. See Manual.		Hazardous voltage. Risk of electric shock.
	Caution. Hot surface.		Protective Earth Ground
	USB connection	CE	Conforms to European Union directives.
	Conforms to relevant North American Safety Standards.		Conforms to relevant Australian EMC standards.
	This product complies with the WEEE Directive (2002/96/EC) marking requirements. The affixed label indicates that you must not discard this electrical/electronic product in domestic household waste. Product Category: With reference to the equipment types in the WEEE Directive Annex I, this product is classed as category 9 "Monitoring and Control Instrumentation" product. Do not dispose of this product as unsorted municipal waste. Go to Fluke's website for recycling information.		

Installation

The subsequent sections give you information on best practices for Product installation.

Unpack and Inspection

Carefully unpack the Product and check for all parts. If there is damage, tell the shipper immediately and make a claim. The parts included are:

- 9118A Calibration Furnace
- Type-S Thermocouple, Long
- Type-S Thermocouple, Short
- Protection Tube, Long
- Protection Tube, Short
- TC Support Bracket
- L-Key, Hex 3 mm
- Button Head Screw, M5X12 (2 each)
- Getting Started Manual
- Users Manual CD-ROM
- Ground Wire
- Serial Cable
- USB Cable
- Super Wool Insulator
- Calibration Certificate

- Isothermal Block
- Rear Plug
- Rear Plug for backup

The last 3 items are only for the thermocouple calibration furnace with isothermal block.

Placement

For best results, choose a location to setup the Product where room temperature changes are minimum. To safely remove heat, put the Product in a position with a minimum of 45 cm of free air space around it.

Fluke Calibration recommends that you do a test for axial uniformity and adjust if necessary after the Product is installed. Temperature uniformity of the Product could be affected by the environment where the Product operates or by equipment or material placed inside or at the ends of the central tube. Refer to the Calibration section of this manual.

Dry-Out Period

Before initial use, after transport, or the Product has not been energized for more than 10 days, turn on the Product for a minimum of 2 hours.

If the Product is wet or was in a wet environment, remove moisture before you turn on the Product.

How to Move the Product

⚠⚠ Warning

To prevent personal injury, use proper techniques to lift the Product.

When you lift the Product, bend your knees and lift with your legs. Before you move the Product, let it cool to ambient temperatures and remove the control and cutout thermocouples and all objects in the furnace well. To safely move the Product, two people are necessary. Put one person in the front and one person at the rear of the Product. Carefully put your hands under the Product and lift in unison.

⚠ Caution

To prevent damage to the Product, remove the isothermal block and rear plug prior to transporting the furnace. The ceramic furnace tube is fragile and can be damaged by the block.

Product Components

As shown in Figure 1 the two primary components of the Product are the furnace and the controller. Figures 2 and 3 show the thermocouple calibration furnace with the isothermal block. The isothermal block shown in Figure 2 is made of aluminum-oxide and provides a constant and accurate temperature environment for the sensor under test. Four 6.7 mm diameter wells are provided.

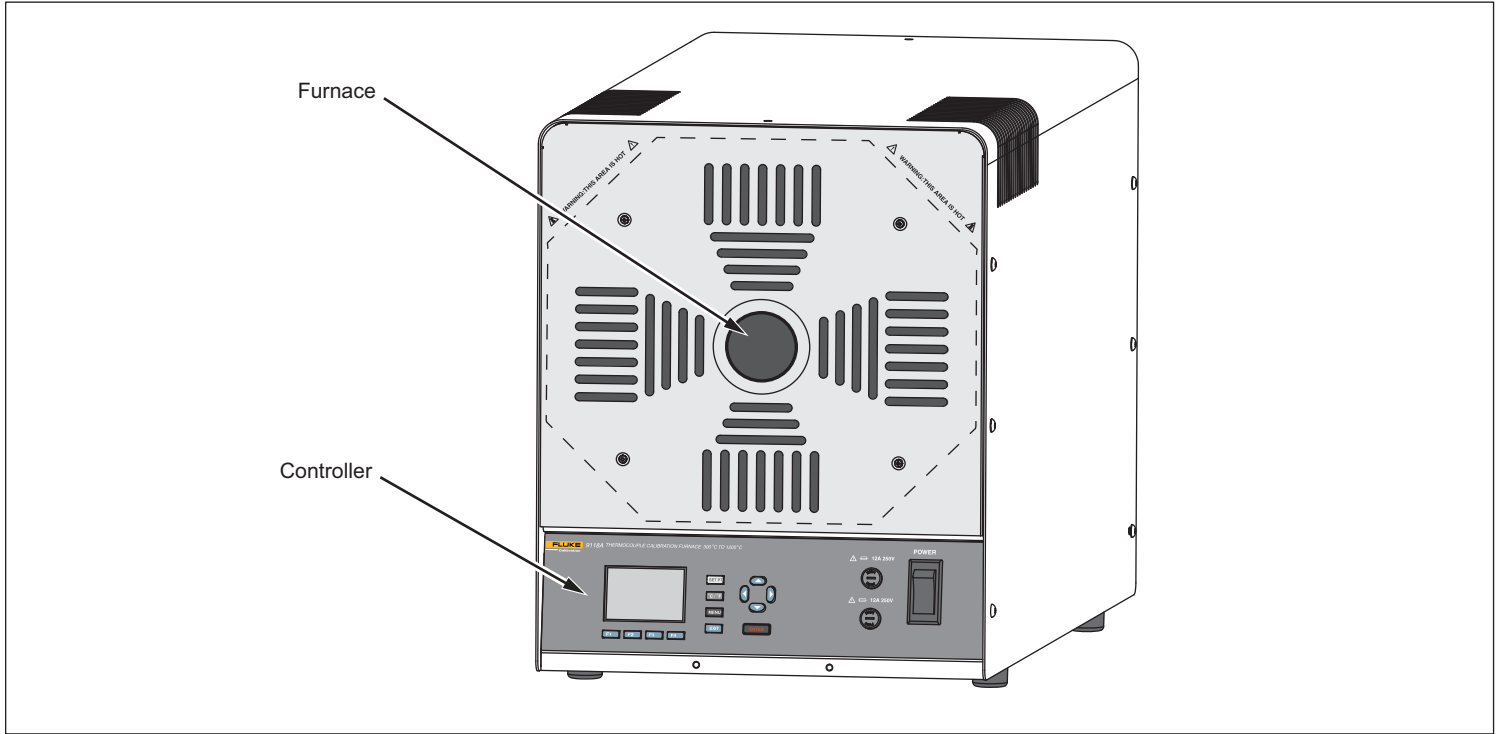
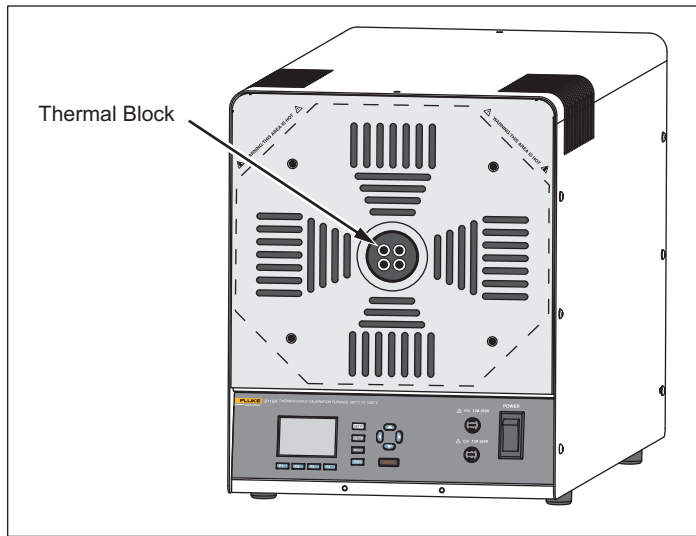

Figure 1. Calibration Tube Furnace

gxs009.eps



gxs121.eps

Figure 2. Front View with Isothermal Block

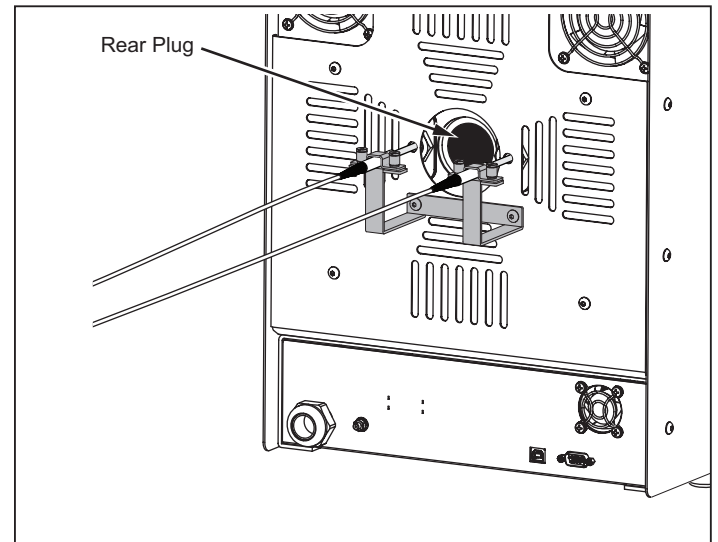

gxs133.eps

Figure 3. Rear View with Isothermal Block

Front-Panel Controls

Figure 4 shows the front-panel controls of the Product and Table 2 is a list of control descriptions.

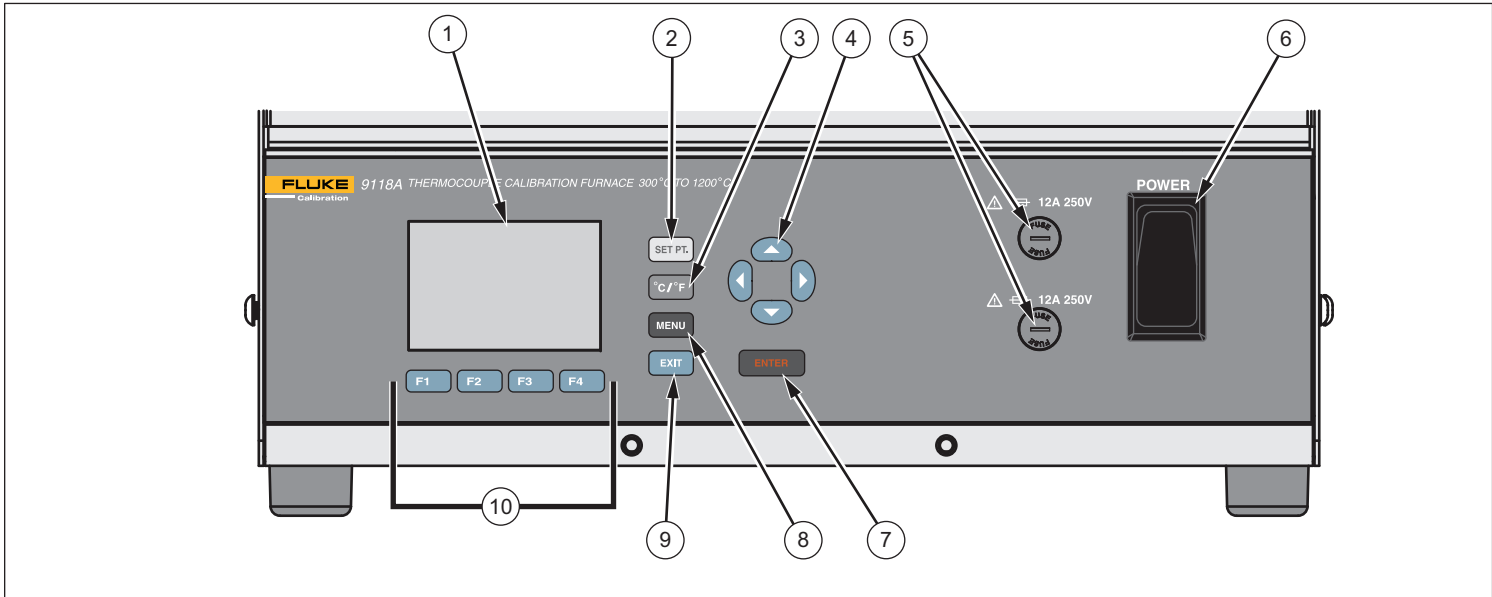

Figure 4. Front-Panel Controls

gxs007.eps

Table 2. Front-Panel Controls

Item	Description	Item	Description
①	LCD Display	⑥	Mains power switch
②	Set a temperature setpoint into the Product.	⑦	Used to set a value into the Product and choose a menu.
③	Sets the Product to show temperatures in Celsius or Fahrenheit.	⑧	Menu button shows the main menu in the display.
④	Moves through menus and adjusts numbers.	⑨	Exits the menu shown in the display and moves to the previous menu.
⑤	Furnace fuses	⑩	Softkeys (F1 through F4) are used to select the function that shows in the display above the softkey.

Rear-Panel Connections

Figure 5 shows the rear-panel connections of the Product and Table 3 is a list of connector descriptions.

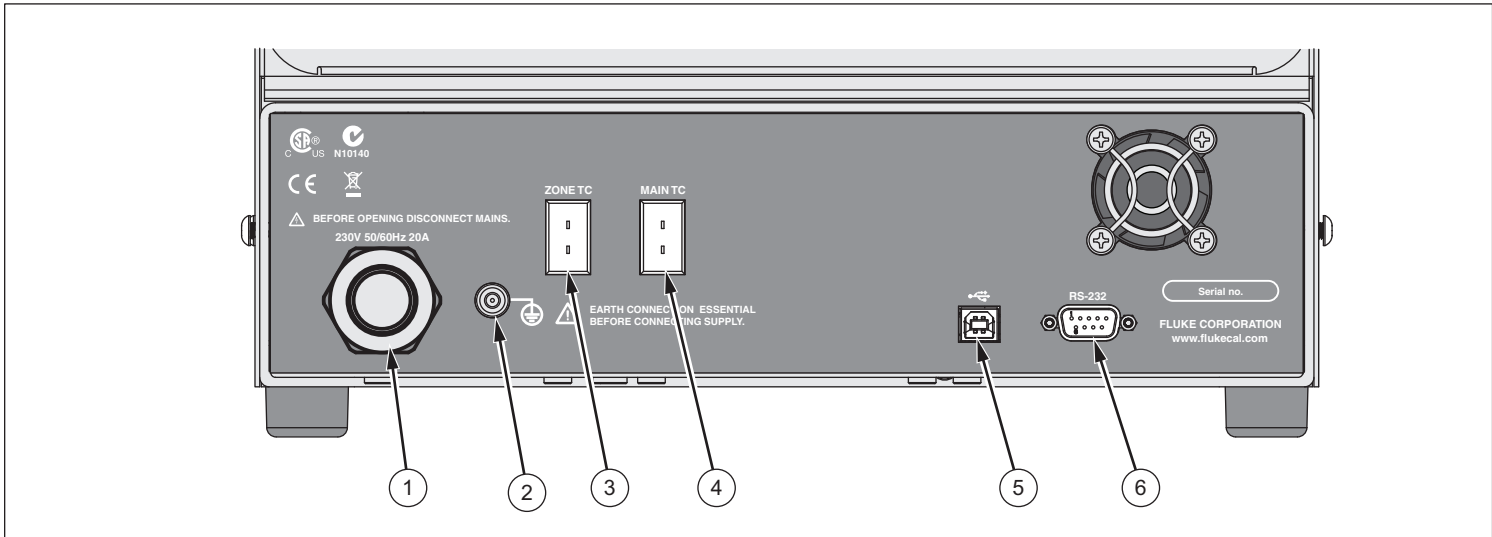

Figure 5. Rear-Panel Connections

gxs008.eps

Table 3. Rear-Panel Connections

Item	Description	Item	Description
①	Mains power cord	④	Main thermocouple input jack
②	Protective Earth Terminal	⑤	USB connector
③	Zone thermocouple input jack	⑥	RS-232 connector

Protection Tube and Support Bracket Installation (and Optional Isothermal Block)

⚠ Warning

To prevent personal injury, disconnect the Product from mains power and when applicable, allow to cool to 80 °C prior to performing any maintenance or installation work on the Product.

To install two protection tubes and a thermocouple (TC) support bracket and optional isothermal block (9118A-ITB):

1. Remove the five socket-head screws and take down the rear shield from unit. See Figure 6.

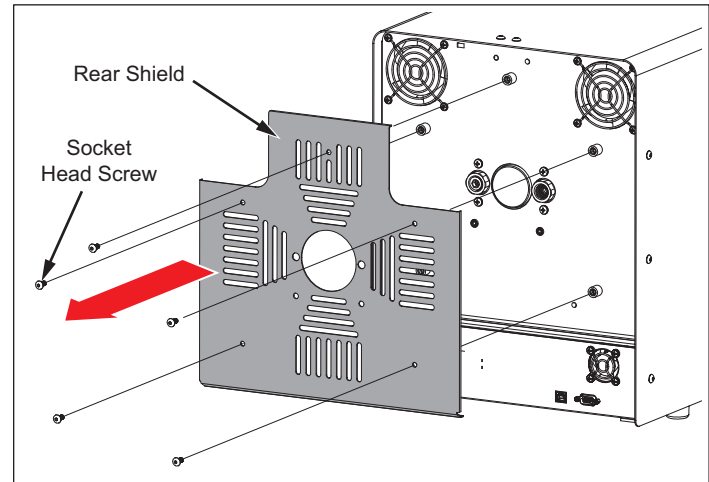

gxs124.eps

Figure 6. Rear View of 9118A Thermocouple
Calibration Furnace with Isothermal Block

2. Insert the long and short protection tubes into flange nuts and screw them into position.
 - Long tube in the right side.
 - Short tube in the left side. See Figure 7.

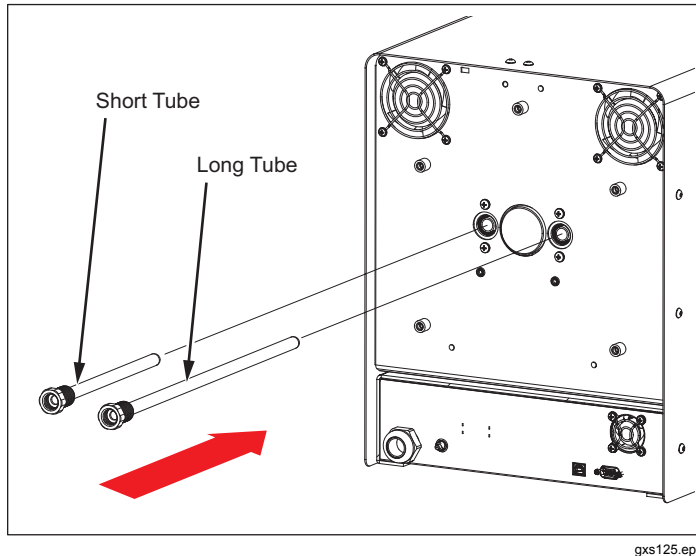

Figure 7. Short Tube and Long Tube Insertion

3. This step is only for the optional isothermal block (9118A-ITB). Insert the rear plug carefully into position. See Figure 8.

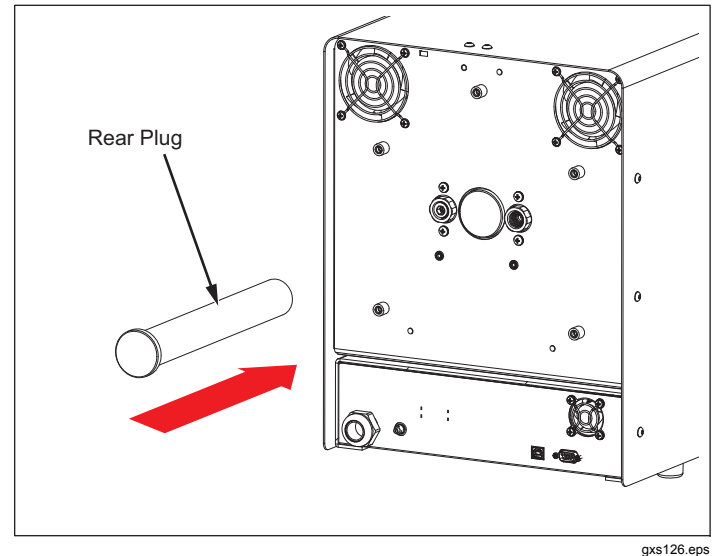
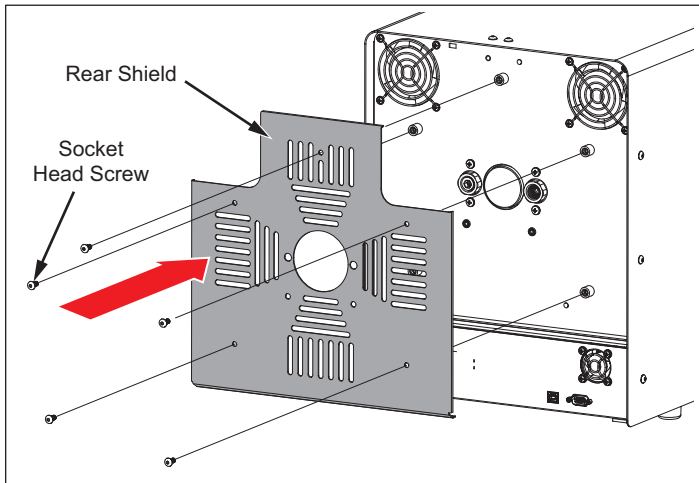

Figure 8. Rear Plug Insertion

4. Attach the rear shield with the five socket-head screws. See Figure 9.



gxs127.eps

Figure 9. Attach the Rear Shield

5. Install the thermocouple support bracket on the rear shield. See Figure 10.

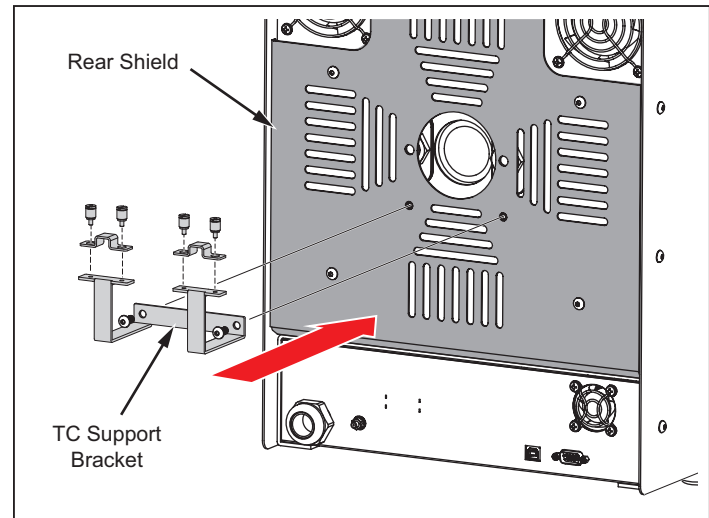

gxs128.eps

Figure 10. Attach the Support Bracket

6. This step is only for the optional isothermal block (9118A-ITB). Insert the isothermal block into the ceramic tube from the front side of the Product. See Figure 6.
- Make sure that the front plug is in contact with the side of the ceramic tube.
 - The position of block must be as shown in Figure 11.

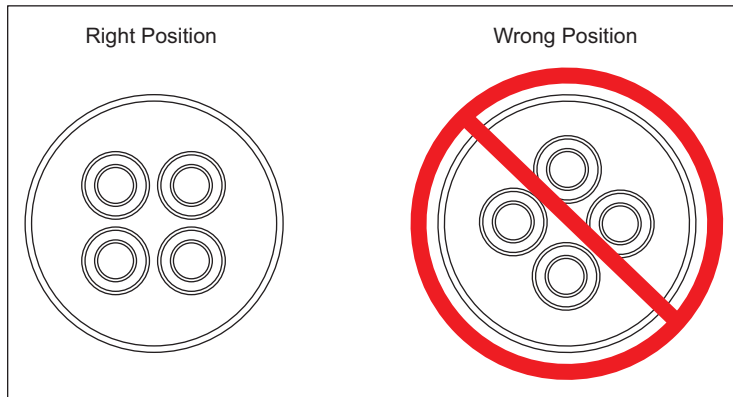

Figure 11. Front Plug Insertion

Probe Installation

Note

When you put the temperature control probes into their applicable protection tube (see steps 2 and 6 below), make sure the end surface of the probe handle is aligned with the edge of the TC support bracket. Failure to do so may cause the Product to be out of calibration.

Two thermocouples are used as temperature control probes. These probes are put into the rear of the furnace and held in position with the TC support bracket.

To install the control probes:

- Put the long probe into the **MAIN TC** tube on the rear panel of the furnace.
- Align the end surface of the thermocouple handle with the front edge of the bracket. See Figures 12 and 13 .
- Tighten the bracket screw to hold the thermocouple in position.
- Connect the cable of the long probe to the **MAIN TC** connector on the rear panel.

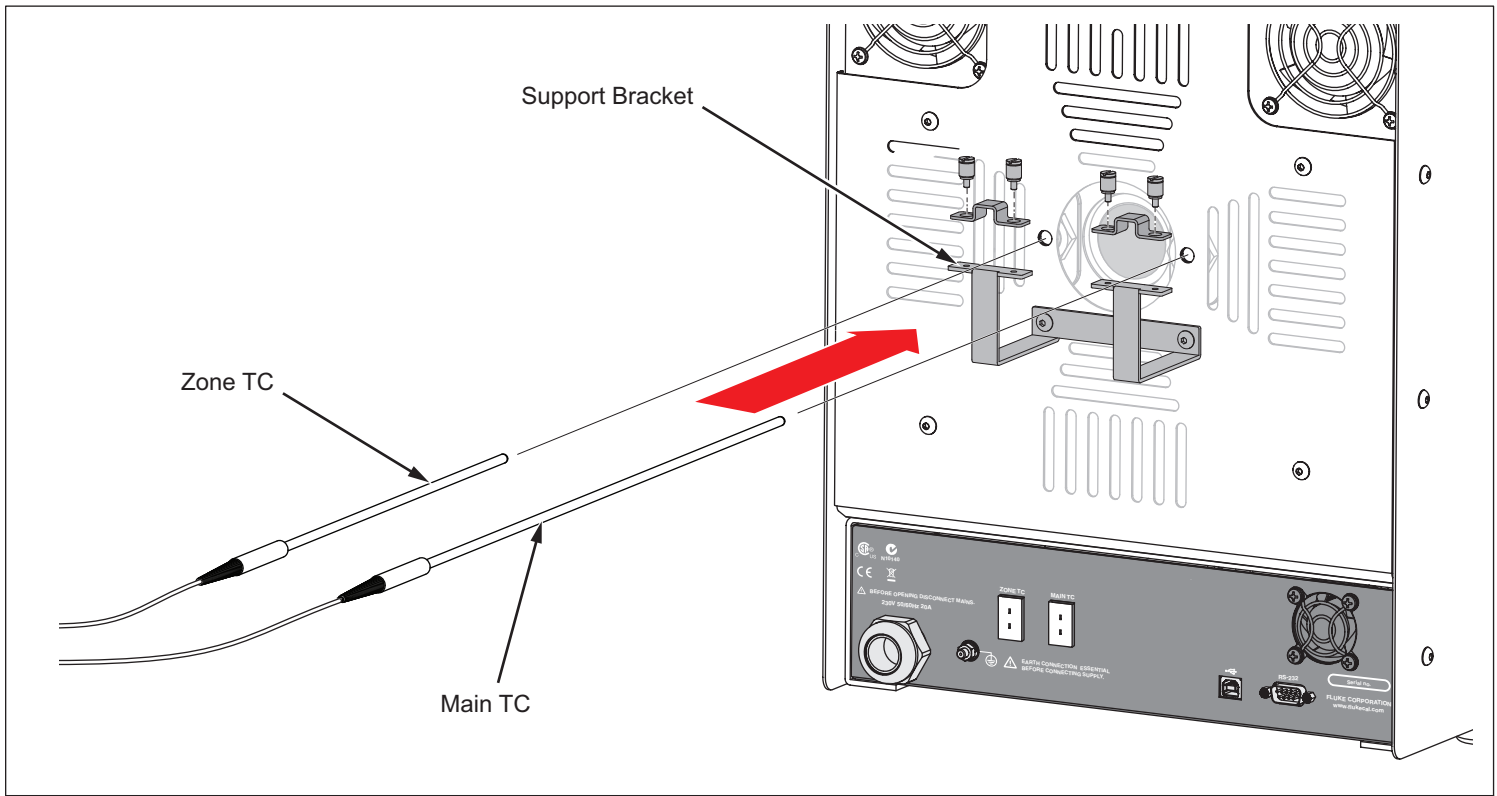

gxs131.eps

Figure 12. Probe Installation A

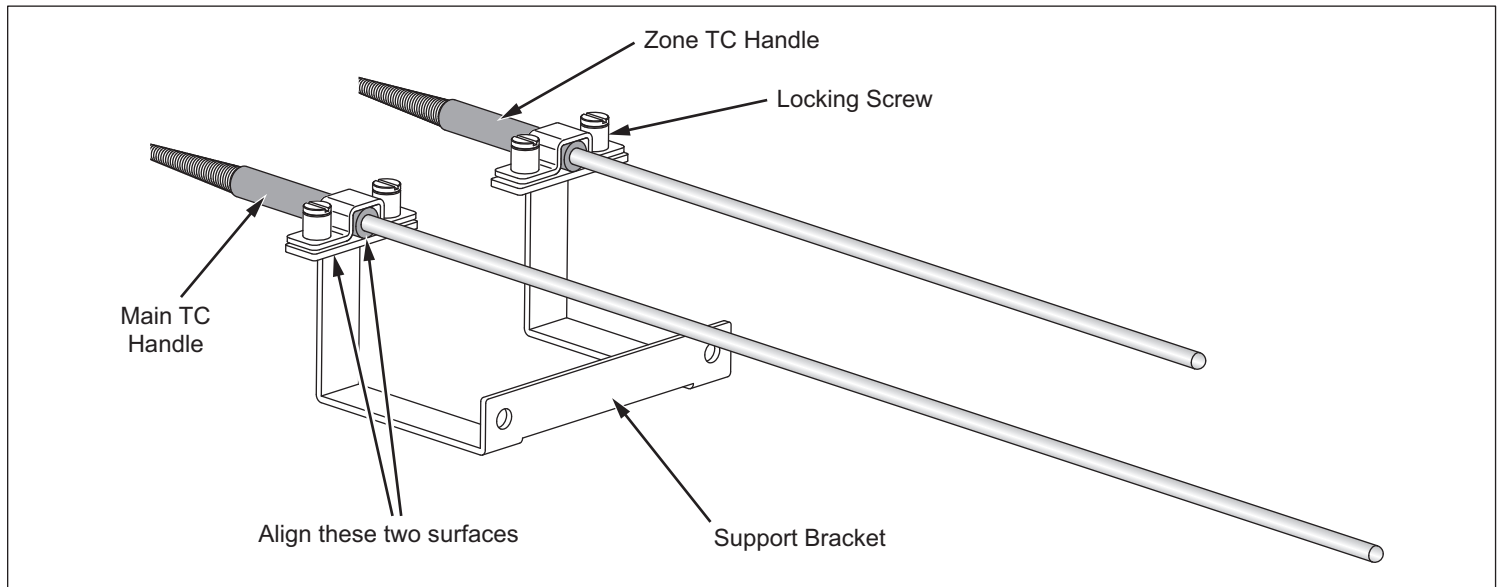

gxs132.eps

Figure 13. Probe Installation B

⚠ Caution

To prevent damage to the thermocouple, do not over tighten the screw.

To prevent contamination of the thermocouple, always wear clean gloves when you handle the thermocouples.

5. Put the short probe into the **ZONE TC** tube on the rear panel of the furnace.
6. Align the end surface of the thermocouple handle with the front edge of the bracket. See Figures 13 and 12.
7. Tighten the bracket screw to hold the thermocouple in position.
8. Connect the cable of the short probe to the **ZONE TC** connector on the rear panel.

The Isothermal Block

The Isothermal Block consists of:

- Front ceramic plug
- Four ceramic guide tubes
- Ceramic block
- Rear ceramic plug

Items 1-3 are fixed together by high temperature cement. The isothermal block is intended to stabilize temperature fluctuations and improve heat conduction between the furnace and the sensor under test. The “block” is made of aluminum-oxide and provides a relatively constant and

accurate temperature environment for the sensor under test. Four 6.7 mm diameter wells are provided.

To install the insert:

1. Carefully remove the isothermal block from the packaging.
The well must be clear of any foreign objects such as dirt or grit before the isothermal block is installed.
2. Carefully insert the isothermal block into the well from the front of the furnace until the front plug contacts the well.
3. Rotate the insert to the correct position, as shown in Figure 14.

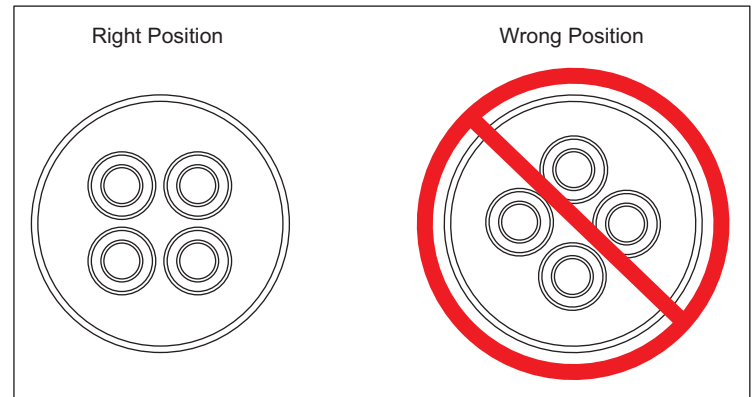

Figure 14. Insert Alignment

4. Insert the rear plug into the well from the rear of the furnace until it contacts the tube.

The fit between the block and the tube is typically loose in order to accommodate thermal expansion.

Connect to Mains Power

⚠⚠ Warning

For safe operation and maintenance of the product, remove moisture from the Product before you connect to mains power. Fluke Calibration recommends the Product be put in a low humidity temperature chamber at 50 °C for 4 hours or more.

To prevent possible electrical shock or personal injury, connect mains power cord correctly and make sure the product is grounded.

Be sure the power cord to the mains supply is wired correctly. The power cord wires are color-coded as follows:

- Black: Line
- White: Neutral
- Green: Ground

Attach a separate safety ground wire between the Protective Earth Terminal on the rear panel of the Product and an earth ground conductor.

Connect the supplied ground wire between the protective earth terminal on the rear panel and earth ground. Use the 2.5 meter power cord to connect the Product to a 230 V ac outlet rated for 20 amps.

How to Turn On the Product

Push the “I” side of the power switch, on the front panel of the Product. The screen shown in Figure 15 shows in the display while the Product does a self test.



Figure 15. Power-Up Screen

When the self test is complete and no errors are sensed, the screen shown in Figure 16 shows in the display. The Product is in a standby mode. You must set a setpoint temperature to start control of the furnace. See the “Adjust Furnace Temperature” section to learn how to start the temperature control of the furnace.

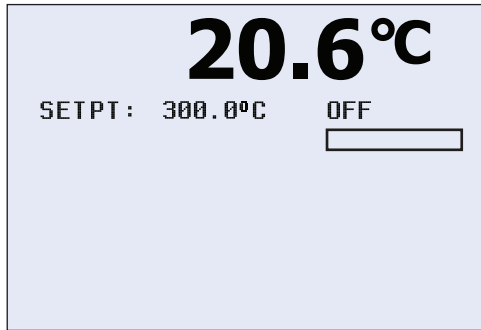

Figure 16. Main Screen

qxs002.bmp

How to Turn Off the Product

⚠ Warning

To avoid personal injury, do not disconnect the product from mains power if the furnace temperature is greater than 80 °C.

⚠ Caution

To prevent possible damage to the Product, disable the temperature control first and then turn off power.

To turn off the Product:

1. Push **SET PT**.
2. Push the softkey under SAVE/DISABLE to disable the heaters.
3. Push the “O” side of the power switch, on the front panel of the Product.

Display

Table 4 is a list of display elements with descriptions.

Table 4. Display Elements

Item	Description
①	Furnace temperature
②	Setpoint temperature
③	Heat/Cool Status
④	Stability Indicator (= stable, = unstable)
⑤	Softkey functions

Setup

Set the Language

Text in the LCD display can be set to show in a different language. To set the language:

1. Push **MENU**.
2. Push the softkey below **System Menu**.
3. Push the softkey below **Display Menu**.
4. Push **◀** or **▶** to scroll through the languages.
5. When your language is shown in the display, push **ENTER**.

To toggle between the set language and English, push **F1** and **F2** at the same time.

Set Display Contrast

With the main screen shown in the display, push **▲** to decrease display contrast. Push **▼** to increase display contrast.

Operation

Warning

For safe operation and maintenance of the product:

- Energize the Product for a 2 hour dry-out period before use, if the Product was:
 - In transport
 - In a humid or semi-humid storage environment
 - Not energized for more than 10 days
- Remove moisture from the Product before you connect to mains power. Fluke Calibration recommends the Product be put in a low humidity temperature chamber at 50 °C for 4 hours or more. While the Product dries, do not assume the Product complies with all safety standards.
- Put temperature probes you remove from the Product on a heat resistant rack or surface until they are safe to touch.
- Keep a minimum of 45 cm clearance from the front, left, and right sides. Keep 150 cm from the top of the Product.

Notes

In order for the Product to perform within specification, the open ends of the furnace tube (both front and rear) must be filled with a temperature-resistant fiber ceramic insulating material such as a Superwool Plus Blanket.

Fiber ceramic insulation contains a binding material that will off-gas when first exposed to high temperatures producing a harmless odor. Once the binding material has off-gassed completely, the odor will no longer persist with subsequent uses of the furnace.

Warning

To avoid personal injury or skin irritation, wear disposable latex gloves (or equivalent) when handling fiber ceramic material.

The front-panel controls let you set the parameters of the Product and monitor its performance. You can also set the parameters of the communication interface. Four softkeys are used to navigate through the menus of the Product. The menus let you setup the Product and change system parameters as necessary.

How to Set Parameters in the Product

There are two methods to set a parameter in the Product. You can set a parameter from a list of values or in the case of numerical values, set a parameter with the cursor keys.

Value List

An example where you select from a list of values is the preset selection.

1. From the main screen, push **SET PT.**.
2. Push the softkey below **SELECT PRESET** in the display.

As shown in Figure 17, the number 1 is highlighted to the right of **PRESET:**.

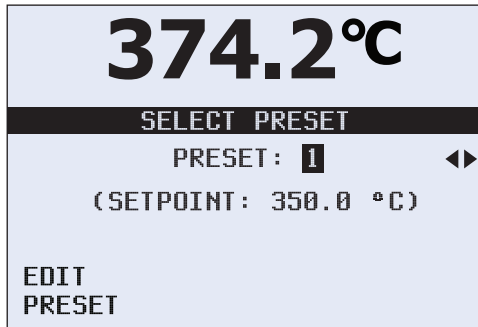

Figure 17. Preset Selection

gxs111.eps

3. To change the preset number, push **◀** and **▶** to scroll through the preset numbers.

4. Push **ENTER** when the correct preset number is shown in the display.

This is the selection method for value lists.

Set Number Value

An example where you set a number is where you set the setpoint temperature.

1. From the main screen, push **SET PT.**.
2. Push **ENTER**.

As shown in Figure 18 the left most digit in the **SETPOINT** temperature is highlighted.

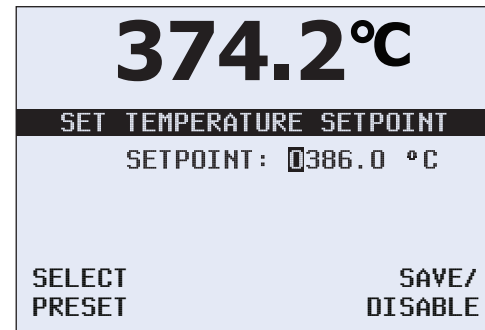





Figure 18. SETPOINT Temperature

gxs110.eps

3. Push  or  to increase or decrease the highlighted digit.
4. Push  to move the highlight to the next digit.
5. Do steps 3 and 4 again for each digit in the number.
6. After all digits are set, push **ENTER**.

Softkey Menus

The softkeys are identified in Table 2. The softkeys are used with the front-panel **MENU** key. The functions of the four softkeys are identified by label information shown directly above each key.

A group of softkey labels is a menu. A group of connected menus makes a menu tree. Figure 19 shows the menu-tree structure for the Product. Figure 20 shows each menu in the menu tree.

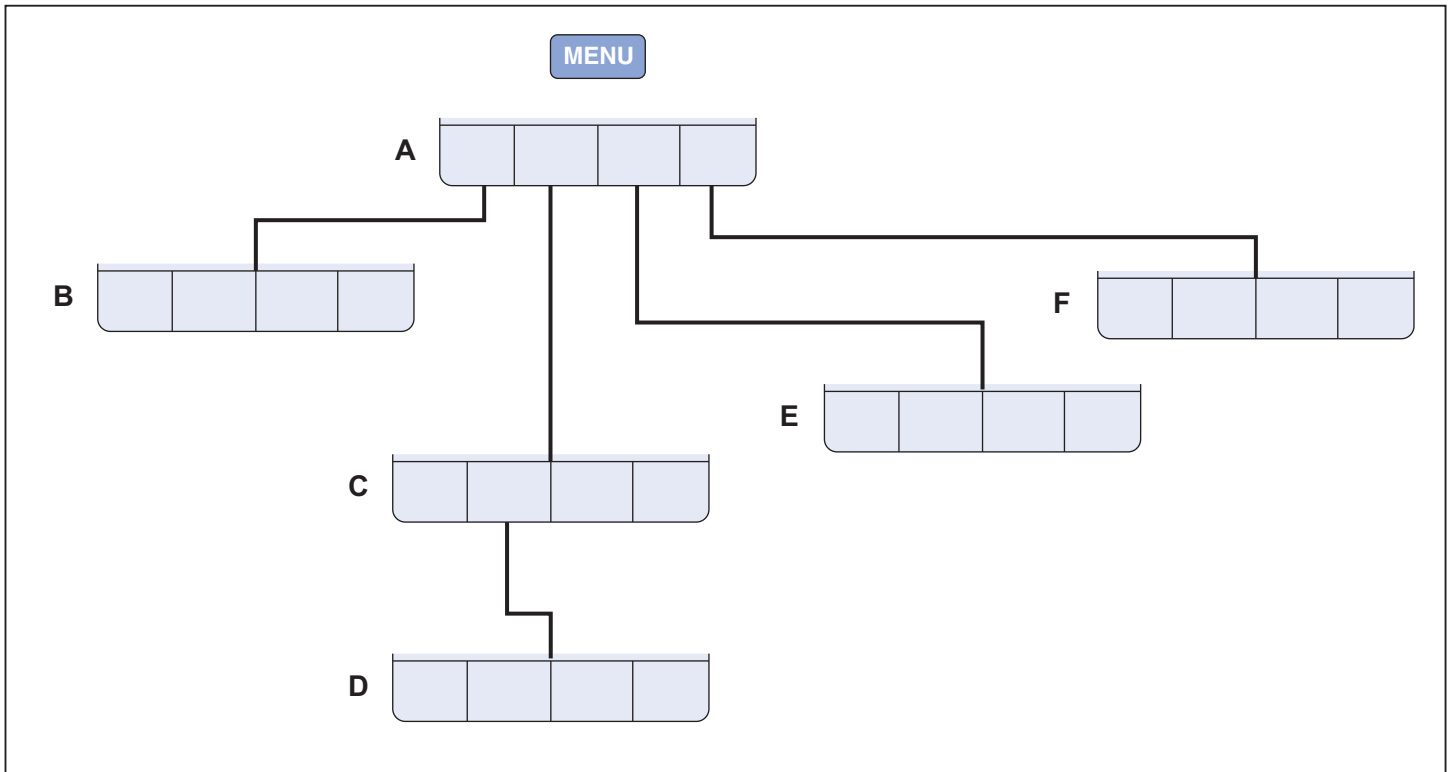

gxs003.eps

Figure 19. Softkey Menu Tree

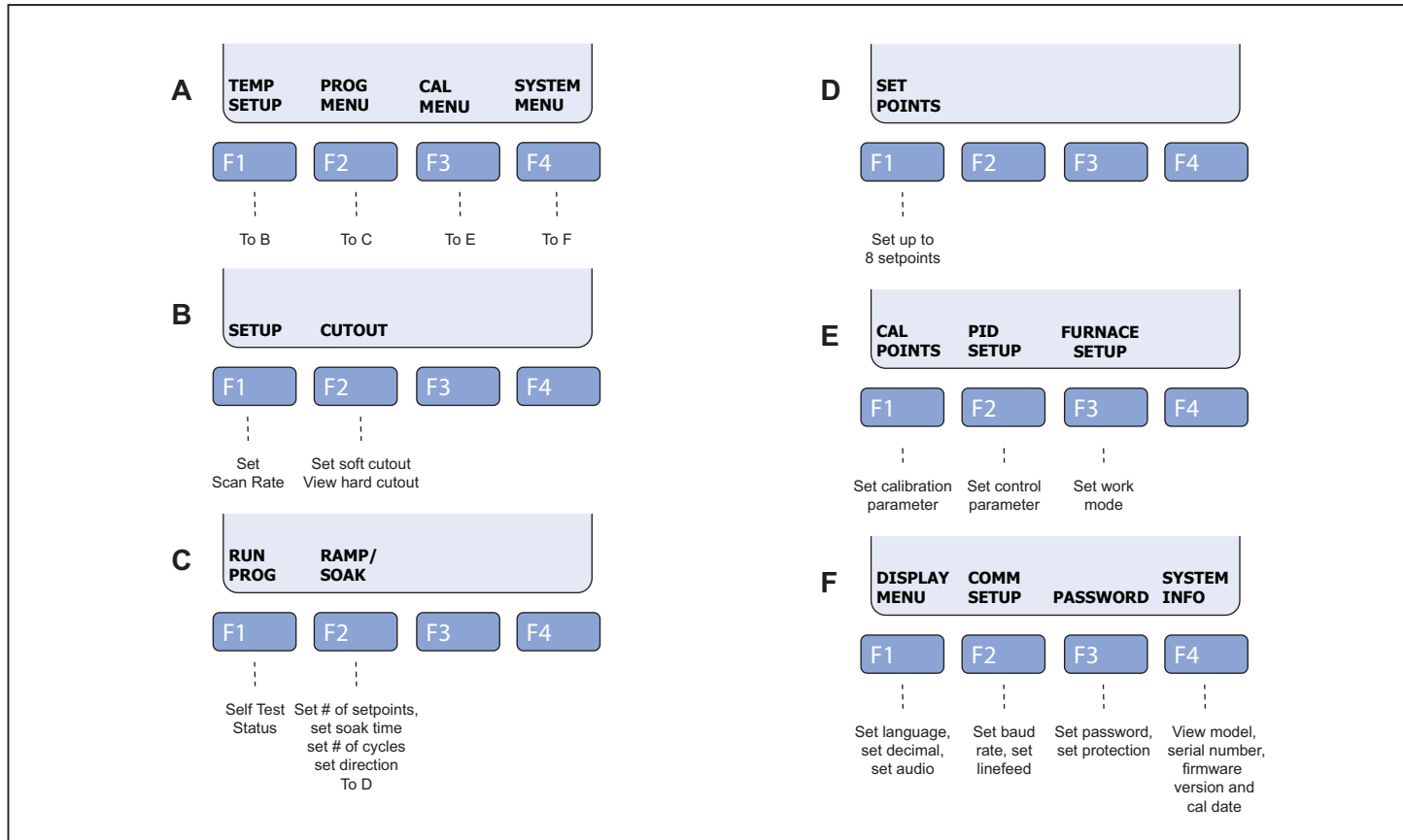

Figure 20. Menu Softkey Displays

gxs004.eps

Temperature (TEMP) Setup Menu

Push the softkey under **TEMP SETUP** to set the scan rate and cutout parameters.

Scan Rate

The **SCAN RATE** parameter sets the rate at which the Product increases or decreases the temperature to a new setpoint. The scan rate can be set between 0.1 °C to 80.0 °C/minute.

Note

The maximum scan rate is the natural rate the Product heats and cools. This is less than the maximum scan rate parameter value.

Cutout

In the cutout menu, there are two parameters: soft and hard cutout. The Product has an adjustable cutout device that turns off power to the heat source if the temperature is higher than a set value.

Use the soft cutout parameter to cut out at the high temperature limit of the probes under calibration. Fluke Calibration recommends you set the cutout 5 °C to 10 °C below the high temperature limit of the probe under test.

When the cutout opens, the Product shows **CUTOUT** in the display, turns off power to the heater, and sets the Product to cool. The Product stays in the cutout condition until the temperature drops below the cutout temperature and the Product is reset by the operator.

To reset the Product after the temperature drops below the cutout value:

1. Push **SET PT.**.
2. Push **ENTER**. If it is necessary to change the setpoint temperature, use the cursor buttons to change the value.
3. Push **ENTER** again.

The **HARD CUTOUT** parameter is set at the factory and is not user settable. This menu selection only lets you see the cutout value.

Program (PROG) Menu

Push the softkey under **PROG** to show the **RAMP/SOAK** and **RUN PROG** menus.

RAMP/SOAK Menu

The RAMP/SOAK feature lets the user program setpoint temperatures and set the time the Product holds the temperature at each setpoint. The Product automatically heats or cools to the programmed setpoint and holds that temperature for the specified time.

The **NO. SETPOINTS** parameter is used to set the number of different temperatures the ramp/soak function will use in the program. You can set a maximum of eight temperature setpoints.

The **SOAK TIME** parameter is used to set the number of minutes each setpoint temperature is held before it changes to the subsequent setpoint. Soak time starts when the temperature is stable.

The **NO. CYCLES** parameter is used to set how many times the setpoint sequence is to be done again.

The **DIRECTION** parameter is used to set how the setpoints sequence before the sequence is done again. When set to →, the Product does the setpoints in one direction from 1 to 8. If set to ↻, it does the setpoints from 1 to 8 and then back to 1 before the sequence is done again.

RUN PROG Function

Use the RUN PROG function to start and stop the test set up through the RAMP/SOAK menu. With the TEST STATUS parameter highlighted, push **←** or **→** to change the test status and push **ENTER**. When set to RUN, the furnace uses the values set through the RAMP/SOAK menu to control the furnace. When the furnace does all the values in the RAMP/SOAK parameters, the status changes to OFF. To stop a test, set the parameter to OFF.

Calibration (CALIB) Menu

Note

Calibration parameters must be correct for the Product to operate correctly.

The **CALIB** menu lets you get access to the calibration points constants and the controller parameters.

Calibration (CAL) Points Menu

When you push the **CAL POINTS** softkey, the product prompts you for a numeric password. You must know the password before you can change a calibration point.

There are 12 calibration points: Zone 1 (300), Skew 1 (300), Temp 1 (300), Zone 2 (700), Skew 2 (700), Temp 2 (700), Zone 3 (1000), Skew 3 (1000), Temp 3 (1000), Zone 4 (1200), Skew 4 (1200), and Temp 4 (1200).

The TEMP parameter adjusts the actual temperature at the midpoint location for the applicable set-point temperature, but does not change the temperature gradient. The ZONE parameter increases or decreases the temperatures in the outer areas of the access tube for an applicable setpoint temperature. The curvature of the temperature profile is adjusted, and does not have an effect on the temperature at the midpoint location or the slope of the temperature profile at the midpoint location. The SKEW parameter adjusts the slope of the temperature profile at the midpoint location for the applicable setpoint temperature. This increases the temperature of one end of the access tube and decreases the temperature of the opposite end.

PID Setup Menu

The **PID SETUP** menu is used to set controller parameters.

The **TEMP PB** parameter is the main proportional band and the gain that the proportional-integral-derivative (PID) controller uses for control.

The **TEMP INT** parameter lets you set the time the controller uses for control. The time is in seconds.

The **TEMP DER** parameter lets you set the derivative time the controller uses for control. The time is in seconds.

Furnace Setup Menu

To operate the Product with or without an isothermal block.

1. From the calibration menu, push the **Furnace Setup** softkey.
2. Enter the password.
3. Push **ENTER**.
4. Push **◀** or **▶** to scroll through the display status of “YES” and “NO”. Select “YES” to set the Product to work with the isothermal block installed. Select “NO” to set the Product to work without the isothermal block installed.
5. Push **ENTER** to save the selected mode.

⚠ Caution

The Product can be used with or without an isothermal block installed. To prevent damage to the Product, unique calibration parameters are necessary for each mode of operation. Before Product use, select the appropriate mode of operation in the calibration menu. When the mode of operation is changed, calibration for the new mode of operation may be required.

System Menu

The **SYSTEM** menu lets you get access to the display menu to set the language, set the type of decimal character, and turn off and turn on key audio. The communication setup parameters, password, and system information are also available through this menu.

Display (DISP) Menu

The **LANGUAGE** parameter is used to set the language used in the display.

The **DECIMAL** parameter is used to set the decimal character to a period or a comma.

The **KEY AUDIO** parameter is used to turn off and turn on the audio feedback when a key is pushed.

Communications (COMM) Setup Menu

The **BAUD RATE** parameter lets you set the baud rate for the RS-232 communications port.

The **LINEFEED** parameter turns on and turns off the line feed character sent across the RS-232 communications port.

Password Setup Menu

The **PASSWORD** menu lets you set the user password and set the level of protection for specified parameters. A password is necessary to access the password menu.

The **USER PASSWORD** parameter is used to set the password for the system that is used to access some menus. The password is a four-digit number where each digit is a number from 1 to 9. The default password is "1234".

The **PROTECTION** parameter sets the level of password protection in the Product. If set to HIGH, then a password is necessary to access the Cutout menu, Ramp/Soak menu, CALIB (Calibration) menu, and PROG menu. When set to LOW, only CALIB and PROG menus are password protected.

System Information (INFO) Menu

The **SYSTEM INFO** menu is a view only menu. This menu shows the Product model number, serial number, firmware version, and the calibration date.

Adjust Furnace Temperature

There are two methods to adjust the furnace temperature. You can recall a preset temperature or set a temperature setpoint manually. The term "setpoint" refers to the temperature the furnace goes to and holds.

Set the Furnace Temperature with a Preset

The Product stores eight preset setpoint temperatures. You can set each preset setpoint as necessary. To set the setpoint to a preset temperature:

1. Push **SET PT.**
2. Push the softkey below **SELECT PRESET**.
3. Push **▲** or **▼** to move between presets (1 through 8). In Figure 21, the temperature of the preset is shown in the display.

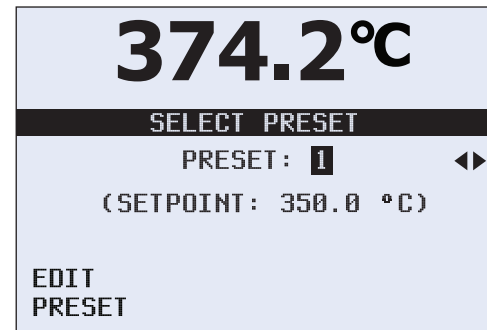

gxs111.eps

Figure 21. Preset Selection

4. With a preset number highlighted, push **ENTER**.

Note

*If the Product is in standby mode, you must push **ENTER** again to start the furnace.*

Set the Furnace Temperature Manually

To adjust the furnace temperature manually:

1. Push **SET PT.**.
2. Push **ENTER**.
3. Push **▲** to increase the temperature or push **▼** to decrease the setpoint temperature.

Note

When you push the up or down key momentarily, the setpoint temperature moves by one step. Push and hold the key and the setpoint temperature increases or decreases until the key is released.

4. Push **ENTER** to save the setpoint temperature and start the furnace.

Note

After a maximum of 5 seconds, the furnace starts to heat or cool to the setpoint temperature.

The actual temperature is the measured temperature in the furnace and lags the setpoint temperature. The lag interval is the time necessary to increase or decrease the temperature of the center of the furnace.

How to Stop the Furnace Heat Cycle

To stop the furnace heat cycle:

1. With the main screen in the display, push **SET PT.**.
2. Push the softkey below **SAVE/DISABLE**.

The heat or cool procedure stops and the Product is set to standby mode.

Change a Preset Temperature

You can set the temperature of the eight presets. To change a preset temperature:

1. Push **SET PT.**.
2. Push the softkey below **SELECT PRESET**.
3. Push **▲** or **▼** to scroll to the preset to change.
4. Push the softkey below **EDIT PRESET**. As shown in Figure 22 the temperature of the selected preset is highlighted in the display.

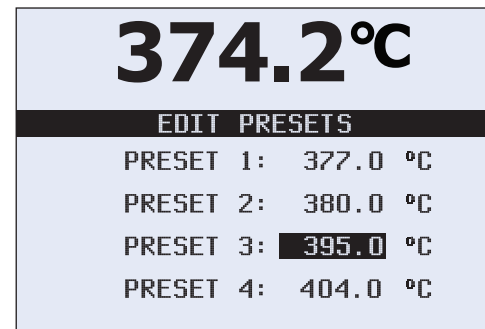

Figure 22. Change Preset Temperature

gxs112.eps

5. Push **ENTER**.
6. The highlight moves to the most significant digit of the temperature.
7. Push **▲** or **▼** to change the digit.
8. Push **▶** to move the highlight to the next digit.
9. Do steps 7 and 8 again until all digits are set.
10. Push **ENTER** to set the preset value.

Note

*If the preset you edited is not number 8, then the highlight moves to the subsequent preset. You can push **ENTER** to edit that preset. If the edited preset is number 8, then the screen goes back to the select preset screen.*

Probe Insertion

⚠ Caution

To prevent possible damage to probes, make sure all probes put into the furnace are rated for the temperature range used in the calibration procedure.

Note

Fluke Calibration recommends you use a metal and/or ceramic fiber surface or container to set hot probes on.

For the best stable temperature and minimum gradient, put sample probes into the full depth of the holes in the isothermal block or the center of the furnace tube if the

isothermal block is not installed. Variations in equipment, probe dimension, and configuration can have an effect on temperature stability and gradients.

Note

A solid (unstirred) mass, as in a furnace, can have heat loss through the probe stem. The loss changes between probes and temperatures.

Cutouts

The Product has five cutout functions: soft cutout, hard cutout, chassis thermostat cutout, TC and heater cutout, and fan fault cutout. Only the soft cutout can be set through the user interface.

Soft Cutout

The soft cutout prevents damage to the Product and temperature probes. Use the soft cutout to turn off power to the furnace so the probes do not become too hot.

The temperature at which the soft cutout turns off power to the furnace can be set through the user interface. See the Temperature Setup Menu section to learn how to set the soft cutout temperature. Set the cutout temperature to ± 10 °C of the temperature limit of the equipment under calibration.

When the soft cutout turns off power to the furnace, **CUTOUT** shows in the display. The Product stays in this condition until the temperature of the furnace goes below the cutout temperature and the setpoint is set again.

Hard Cutout

The Hard Cutout disables the heaters if the control thermocouples sense that the furnace temperature is above a factory-set limit. It also cuts out if a control thermocouple is open-circuit or disconnected.

The hard cutout temperature is set at the factory and can be seen through the user interface. This is not a user-accessible parameter. When the hard cutout turns off power to the furnace, the temperature must decrease a few degrees below the hard cutout temperature to reset.

Chassis Thermostat Cutout

The Chassis Thermostat Cutout turns off power if the chassis temperature is too hot. The power stays off until the temperature of the chassis decreases a few degrees below the cutout temperature. This is not a user-accessible adjustment.

Fan Fault Cutout

The Fan Fault Cutout turns off power to the furnace when a fan fails. The furnace stays off until the fan is repaired.

TC or Heater Fault Cutout

The TC Fault Cutout turns off power to the furnace when the product senses there is a problem with a control probe or a heater. This protects the Product when a control probe comes out of its socket or a wire in one of the

probes opens. This cutout also turns off the furnace if it is in the heat mode and the temperature of the furnace does not increase. When this cutout turns off furnace power, **TC OR HEATER FAULT!** shows in the display. The probe or heater must be repaired or replaced to reset this cutout.

Remote Operation

Remote operation of the Product from a PC or computer is done with commands through the remote interface. The command set will let you set setpoint temperatures, monitor furnace temperature, get measurement data, and control furnace operation. This section contains the procedures to set up, configure, and operate the Product through the remote interface.

The Product is controlled with Standard Commands and Programmable Instruments (SCPI) commands. The SCPI command set and how the Product implements those commands is included in the SCPI Commands section of this manual.

Digital Communication Interface

There is an RS-232C and USB interface on the rear panel of the Product. See Figure 5. To prevent noise on the signal wires, use a shielded low-resistance cable between the Product and PC.

Figure 23 shows the cable connections that connects the PC to the Product. The connections shown in the figure are for a DB 9-pin connector and DB 25-pin connector on the PC.

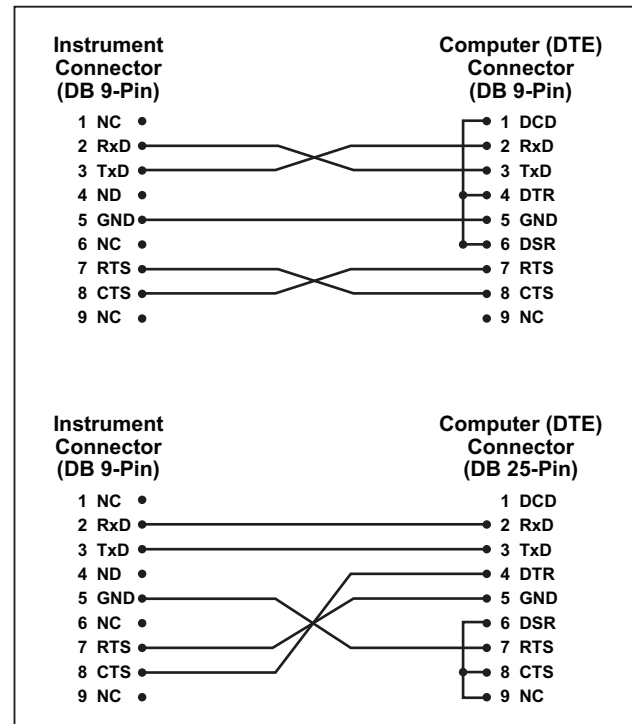

gxs005.eps

Figure 23. RS-232 Cable Connections

To use the USB interface for remote operation, you must install a driver on the PC. The driver is found on the 9118A CD-ROM.

To get an up-to-date USB driver, go to <http://www.ftdichip.com/Drivers/VCP.thm>.

How to Configure the Digital Interface

To control the Product with a PC, you must set the parameters of the digital interface in the Product. To set the interface parameters:

1. Push **MENU**.
2. Push the softkey below **SYSTEM MENU**.
3. Push the softkey below **COMM SETUP**.
4. Set the RS-232 parameters to the values as the parameter values for the PC interface.

Input Terminators

An input terminator is a character sent by the PC that identifies the end of a string. When the Product receives an input terminator, it does the command preceding the terminator character.

Applicable terminators are:

- LF (Line Feed)
- CR (Carriage Return)
- CR LF (Carriage Return/Line Feed)

In some instances, a terminator is automatically sent at the end of an output string from the PC.

SCPI Commands

This section gives all SCPI commands recognized by the Product with their description and syntax rules.

Commands by Function or Group

Table 5 is a list of commands grouped by Calibration, Main Screen, Program, Setup, System, and Temperature.

Table 5. Commands by Function or Group

Group	Screen Parameter	Command	Password Group	Read/Write
Calibration – Controller	TEMP PB	SOUR:LCON:PBAN	Unconditional	R/W
	TEMP INT	SOUR:LCON:INT	Unconditional	R/W
	TEMP DER	SOUR:LCON:DER	Unconditional	R/W
Calibration – Heat Source	TEMP 1	SOUR:SENS:CAL:PAR1	Unconditional	R/W
	TEMP 2	SOUR:SENS:CAL:PAR2	Unconditional	R/W
	TEMP 3	SOUR:SENS:CAL:PAR3	Unconditional	R/W
	TEMP 4	SOUR:SENS:CAL:PAR4	Unconditional	R/W
	GRAD 1	SOUR:SENS:CAL:ZONE1	Unconditional	R/W
	GRAD 2	SOUR:SENS:CAL:ZONE2	Unconditional	R/W
	GRAD 3	SOUR:SENS:CAL:ZONE3	Unconditional	R/W
	GRAD 4	SOUR:SENS:CAL:ZONE4	Unconditional	R/W
	SKEW 1	SOUR:SENS:CAL:SKEW1	Unconditional	R/W
	SKEW 2	SOUR:SENS:CAL:SKEW2	Unconditional	R/W
	SKEW 3	SOUR:SENS:CAL:SKEW3	Unconditional	R/W
	SKEW 4	SOUR:SENS:CAL:SKEW4	Unconditional	R/W
Calibration Furnace	THERMAL BLOCK	SYST:CONF:BLC	Unconditional	R/W

Table 5. Commands by Function or Group (cont.)

Group	Screen Parameter	Command	Password Group	Read/Write
Main Screen	(none)	SOUR:SENS:DATA	N/A	R
	SETPT	SOUR:SPO	N/A	R/W
	HEAT %	OUTP1:DATA	N/A	R
	(none)	OUTP2:DATA	N/A	R
	ENABLE	OUTP1:STAT	N/A	R/W
Program – Run	TEST STATUS	PROG:STAT	N/A	R/W
Program - Setup	TEST ID	PROG:IDEN	N/A	R/W
Ramp & Soak	RAMP/SOAK SETUP	PROG:SEQ:CAT	N/A	R
	SETPOINT n	PROG:SEQ:PAR SPO _n	Conditional	R/W
	SOAK TIME	PROG:SEQ:PAR DWEL	Conditional	R/W
	SETPOINTS	PROG:SEQ:PAR POIN	Conditional	R/W
	NO CYCLES	PROG:SEQ:PAR CYCL	Conditional	R/W
	DIRECTION	PROG:SEQ:PAR DIR	Conditional	R/W
	SETPOINT 1	SOUR:LIST:SPO1	N/A	R/W
	SETPOINT 2	SOUR:LIST:SPO2	N/A	R/W
	SETPOINT 3	SOUR:LIST:SPO3	N/A	R/W
SETPOINT 4	SOUR:LIST:SPO4	N/A	R/W	

Table 5. Commands by Function or Group (cont.)

Group	Screen Parameter	Command	Password Group	Read/Write
Ramp & Soak (cont.)	SETPOINT 5	SOUR:LIST:SPO5	N/A	R/W
	SETPOINT 6	SOUR:LIST:SPO6	N/A	R/W
	SETPOINT 7	SOUR:LIST:SPO7	N/A	R/W
	SETPOINT 8	SOUR:LIST:SPO8	N/A	R/W
Setup – Communications	BAUD RATE	SYST:COMM:SER:BAUD	N/A	R/W
	LINEFEED	SYST:COMM:SER:LIN	N/A	R/W
Setup – Display	LANGUAGE	SYST:LANG	N/A	R/W
	DECIMAL	SYST:DEC:FORM	N/A	R/W
	KEY AUDIO	SYST:BEEP:KEYB	N/A	R/W
Setup – Password	PASSWORD (Disable)	SYST:PASS:CDIS	Unconditional	W
	PASSWORD (Enable)	SYST:PASS:CEN	Unconditional	W
Status	(none)	SYST:PASS:CEN:STAT	N/A	R
	USER PASSWORD	SYST:PASS:NEW	Unconditional	W
	PROTECTION	SYST:PASS:PROT	N/A	R/W
Setup – Date/Time	DATE	SYST:DATE	Unconditional	R/W
System – Setup	°C/°F	UNIT:TEMP	N/A	R/W
Heat Enable	(none)	OUTP:STAT	N/A	R/W
	(none)	SYST:KLOC	Conditional	R/W

Table 5. Commands by Function or Group (cont.)

Group	Screen Parameter	Command	Password Group	Read/Write
System – Information	(none)	SYST:ERR	N/A	R
	(all)	*IDN	N/A	R
	(none)	*CLS	N/A	W
	(none)	*OPT	N/A	R
	FW VER	SYST:CODE:VERS	N/A	R
Temperature – Cutout	HARD CUTOUT	SOUR:PROT:HCUT	N/A	R
	SOFT CUTOUT	SOUR:PROT:SCUT:LEV	Conditional	R/W
Reset	(none)	SOUR:PROT:CLEA	N/A	W
Trip State	(none)	SOUR:PROT:TRIP	N/A	R
Temperature – Setup	SCAN RATE	SOUR:RATE	N/A	R/W
Monitor Temperature	CJC Temperature	SOUR:SENS:DATA	N/A	R
	Monitor TC	SOUR:SENS:DATA	N/A	R

Alphabetic List of Commands

In this section, commands are shown alphabetically. Each command is shown with its long and short form. For each command there is a description, one or more examples, and a parameter range when applicable.

Note

In this section, square brackets ([]) show optional keywords or parameters. Braces ({ }) enclose parameters inside a command string. Triangle brackets (< >) show that you must replace the parameter with a value. Some commands use upper and lower case letters. You must use all the uppercase letters in a command. The lowercase letters are optional. The “|” is used as a separator between optional parameter values in a command.

All commands used with the Product are sequential. Each command is completed before a subsequent command is processed.

All commands that are not recognized by the Product cause an error message to show in the error queue. A command can be rejected with an error if the command is misspelled, has incorrect syntax, and/or has invalid parameters.

***CLS**

Clears all status registers.

Example: *CLS

Response: None

***IDN?**

Gets manufacturer, model number, serial number and firmware version of the product.

Example: *IDN?

Response: FLUKE, 9118A, 0, 4.03

***OPT?**

Gets product configuration or reference functionality.

Example: *OPT?

Response: 1 Reference hardware is enabled. (0 = disabled)

OUTPut:STATus <n>

Sets or gets the main heat output on or off.

Parameters: n = ON or 1 Turn on main heat.
 OFF or 0 Turn off main heat.

Example: OUTP:STAT 1 Turn on main heat.

OUTPut:STATus?

Gets the main heat output on or off.

Example: OUTP:STAT?

Response: 0 Main heat output is off. (1 = on)

OUTP[n]:DATA?

Gets the duty cycle of a heater duty cycle in percent.

Parameters: n 1 to 3 1 = main heater output (default), 2 = zone heater output, 3 = balance heater output.

Example: OUTP:DATA?

Response: 18.0 Main heater output duty cycle is 18 %.

Example: OUTP2:DATA?

Response: 57.0 Zone heater output duty cycle is 57.0 %.

PROGram:IDEN [quoted string]

Sets the program identifier.

Parameters: string = 1 to 12 characters (0 - 9, A - Z, '-'). Default = "0"

Example: IDEN? "TEST-1"

PROGram:IDEN? <quoted string>

Gets the program identifier.

Example: IDEN?

Response: TEST-1

PROGram:SEQ:CAT?

Gets a parameters list for ramp and soak tests.

Example: PROG:SEQ:CAT?

Response: "SPOn" , "DWELL" , "DIR" , "POIN" , "CYCL"

PROGram:SEQ:PAR <Par>[, n]

Set a parameter in the ramp/soak test.

Parameters: Par = SPO[x] x = 1 to 8 setpoint number. Default = 1. n = 300.00 to 1200.00. Default = 300.00.
DWEL 1 to 100 seconds of soak time. Default = 15.
POIN 1 to 8 setpoints in the ramp/soak test. Default = 8.
CYCL 1 to 999 times the ramp/soak test is to be repeated. Default = 1.
DIR 0 or 1. Sets the direction of how the setpoints will be done in the test. See DIRECTION in the Ramp/Soak Menu section. 0 = Up. 1 = Up then Down. Default = 0.

Example: To make a ramp/soak test with 3 setpoint temperatures of 450 °, 1145 °, and 825 ° that soak for 20 minutes:

PROG:SEQ:PAR POIN,3 Sets three temperature setpoints for the test.
PROG:SEQ:PAR SPO1,450.00 Sets setpoint #1 to 450.00 degrees.
PROG:SEQ:PAR SPO2,1145.00 Sets setpoint #2 to 1145.00 degrees
PROG:SET:PAR SPO3,825 Sets setpoint #3 to 825.00 degrees
PROG:SET:PAR DWEL,20 Sets soak time to 20 minutes.

PROGram:SEQ:PAR? <Par>

Get a parameter from the ramp/soak test.

Parameters: Par = SPO[x] x = 1 to 8 setpoint number. Default = 1. Gets setpoint temperature for the setpoint number.

 DWEL Gets soak time

 POIN Gets the number of setpoints in the ramp/soak test.

 CYCL Gets the number of times the ramp/soak test is to be repeated.

 DIR Gets the direction of how the setpoints will be done in the test. See DIRECTION in the Ramp/Soak Menu section.

Example: PROG:SEQ:PAR? SPO2 Gets the setpoint temperature for setpoint number 2.

PROGram:STATus <n>

Sets the execution state for the selected program.

Parameters: n = RUN or 1 Start the selected program.

 OFF or 0 Stop the selected program. (Default)

Example: PROG:STAT 1 Starts the selected program.

PROGram:STATus?

Sets or gets the execution state for the selected program.

Example: PROG:STAT?

Response: 0 The selected program is stopped.

SOURce:LCON:DER <n>

Sets the main control derivative time in seconds.

Note

This command has password protection. Use the SYST:PASS:CEN command first before you use this command to set this value.

Parameters: n 0.0 to 99.9 seconds.

Example: SOUR:LCON:DER 5

SOURce:LCON:DER?

Gets the main control derivative time in seconds.

Example: SOUR:LCON:DER?

Response: 1.5 The main zone derivative time is 1.5 seconds.

SOURce:LCON:INT <n>

Sets the main control loop integral time in seconds.

Note

This command has password protection. Use the SYST:PASS:CEN command first before you use this command to set this value.

Parameter: n = 10.0 to 999.9 seconds.

Example: SOUR:LCON:INIT 10

SOURce:LCON:INT?

Gets the main control loop integral time in seconds.

Example: SOUR:LCON:INIT?

Response: 20.0 The main control loop integral time is 20.0 seconds.

SOURce:LCON:PBAN <n>

Sets the main control proportional band in °C which the PID controller uses for main zone control.

Parameters: n = 1.0 to 199.9 °C

Example: SOUR:LCON:PBAN 7

SOURce:LCON:PBAN?

Gets the main control proportional band in °C which the PID controller uses for main zone control.

Example: SOUR:LCON:PBAN?

Response: 1.5 The main control loop proportional band is 1.5 °C.

SOURce:LIST:SPO<i> <n>

Sets the temperature value for a preset setpoint in the RAMP/SOAK menu.

Parameters: i = Setpoint number (1 to 8)

n = Setpoint temperature.

Example: SOUR:LIST:SPO6 700.00 Sets setpoint number 6 to 700.00 degrees.

SOURce:LIST:SPO<i>?

Gets the temperature value for a preset setpoint in the RAMP/SOAK menu.

Example: SOUR:LIST:SPO4?

Response: 400.0 The setpoint temperature for setpoint 4 is 400.0 degrees.

SOURce:PROT:HCUT?

Gets the hard cutout temperature setpoint in °C or °F.

Example: SOUR:PROT:HCUT?

Response: 140 The hard cutout temperature is set to 140 °C.

SOURce:PROT:CLEA

Resets the cutout to enable the Product.

Example: SOUR:PROT:CLEA

Response: None

If the furnace goes above the maximum temperature, the cutout circuit will trip. The Product does not heat or cool until the cutout condition is cleared.

SOURce:PROT:SCUT:LEV <n>

Sets the soft cutout temperature.

Note

This command has password protection. Use the SYST:PASS:CEN command first before you use this command to set this value.

Parameters: n = 25.00 to 1240.00 degrees.

Example: SOUR:PROT:SCUT:LEV 450 Sets the soft cutout to 450 degrees.

SOURce:PROT:SCUT:LEV?

Gets the soft cutout temperature.

Example: SOUR:PROT:SCUT:LEV?

Response: 1000 Soft cutout temperature is set to 1000 degrees.

SOURce:PROT:TRIP?

Gets the cutout trip state.

Example: SOUR:PROT:TRIP?

Response: 0 Cutout not tripped (1 = cutout tripped).

SOURce:RATE <n>

Sets the control temperature rate of change (scan rate) in °C or °F per minute.

Parameters: n = 0.10 to 500.00 degrees per minute. Default = 100.00

Example: SOUR:RATE 1.26 Sets the scan rate to 1.26 degrees per minute.

SOURce:RATE?

Gets the control temperature rate of change (scan rate) in °C or °F per minute.

Example: SOUR:RATE?

Response: 0.531 The scan rate is set to 0.531 degrees per minute. The response to this command starts out high and decreases as the temperature gets nearer to the setpoint temperature.

SOURce:SENS:CAL:ZONE <x> <n>

Sets the axial gradient adjustment parameter.

Note

This command has password protection. Use the SYST:PASS:CEN command first before you use this command to set this value.

Parameters: x = 1 to 4 (1 = ZONE1, 2 = ZONE2, 3 = ZONE3, 4 = ZONE4)

n = -10.0 to 10.0 as a temperature offset in °C.

Example: SOUR:SENS:CAL:ZONE2 0.08

SOURce:SENS:CAL:ZONE <x>?

Gets the axial gradient adjustment parameter.

Example: SOUR:SENS:CAL:ZONE2?

Response: 0.05 Axial gradient adjustment is 0.05.

SOURce:SENS:CAL:PAR<x> [n]

Sets a control temperature calibration parameter.

Note

This command has password protection. Use the SYST:PASS:CEN command first before you use this command to set this value.

Parameters: x = 1 to 3 (1 = PAR1 = TEMP 1, 2 = PAR2 = TEMP 2, 3 = PAR3 = TEMP 3, 4 = TEMP 4)
n = -50.00 to +50.00 (Default = 0.000)

Example: SOUR:SENS:CAL:PAR2 0.02 Set the calibration parameter to 0.02 for main control.

SOURce:SENS:CAL:PAR<x>?

Gets a control temperature calibration parameter.

Example: SOUR:SENS:CAL:PAR2?

Response: 0.0 The calibration parameter #2 is set to 0.0.

SOURce:SENS:CAL:TEMP[n]?

Gets the temperature of a calibration parameter. This temperature is fixed and is in degrees Celsius.

Parameter: n = 1 to 3 (1 = TEMP1, 2 = TEMP2, 3 = TEMP3). Default = 1

Example: SOUR:SENS:CAL:TEMP1?

Response: 300 The temperature value of the TEMP1 parameter is 300 °C.

SOURce:SENS:CAL:SKEW<x> <n>

Sets an axial compensation adjustment parameter.

Note

This command has password protection. Use the SYST:PASS:CEN command first before you use this command to set this value.

Parameters: x = 1 to 4 (1 = SKEW1, 2 = SKEW2, 3 = SKEW3, 4 = SKEW4)

n = -10.00 to 10.00

Example: SOUR:SENS:CAL:SKEW2 0.08

SOURCE:SENS:CAL:SKEW<x>?

Gets an axial compensation adjustment parameter.

Example: SOUR:SENS:CAL:SKEW2?

Response: 0.05 The axial compensation for SKEW2 is 0.05 of the main heater power.

SYST:CONF:BLC [n]

Sets the furnace work mode with the isothermal block inside or without the isothermal block inside.

Parameters: n =0 determines if the furnace will work without the isothermal block inside
 =1 determines if the furnace will work with the isothermal block inside

Example: SYST:CONF:BLC 1 Determines if the furnace is to work with the isothermal block inside.

SYST:CONF:BLC?

Gets the furnace work mode with the isothermal block inside or without the isothermal block inside.

Example: SYST:CONF:BLC?

Response: 0 The furnace works without the isothermal block inside

SOURCE:SENS:DATA? [heater part]

Gets the control temperature of the parts of the furnace.

Parameters: heater part MAIN – gets main heater temperature (Default)
 ZONE – gets zone heater temperature
 FULL – gets main and zone heater temperature

Example: SOUR:SENS:DATA? MAIN

Response: 700.00 Main temperature is 700.00 degrees.

Example: SOUR:SENS:DATA? FULL

Response: 700.00,600.00 Main temperature is 700.00 degrees and zone temperature is 600.00 degrees.

SOURce:SENS:DATA? [sensor function]

Gets sensor temperature in °C or °F.

Parameters: function = CJC – CJC Sensor temperature
 MTC – Monitor TC sensor

Example: SOUR:SENS:DATA? CJC

Response: 36.12 The CJC sensor is at 36.12 °C.

SOURce:SPO [n]

Sets the control setpoint.

Parameters: n = 300.00 to 1200.00 degrees Celsius (Default = 300.00).

Note

This command has password protection. Use the SYST:PASS:CEN command first before you use this command to set this value.

Example: SOUR:SPO 400.00 Sets the setpoint temperature to 400.00 degrees.

SOURce:SPO?

Gets the control setpoint.

Example: SOUR:SPO?

Response: 300.00 Setpoint temperature is set to 300.00 degrees.

SYSTem:BEEP:KEYB [n]

Sets the state of the keyboard beep function.

Parameters: n = ON or 1 Turn on keyboard beep. (Default)
 OFF or 0 Turn off keyboard beep.

Example: SYST:BEEP 1 Turn on keyboard beep.

SYSTem:BEEP:KEYB?

Gets the state of the keyboard beep function.

Example: SYST:BEEP?

Response: 0 keyboard beep is off. (1 = on)

SYSTem:CODE:VERS?

Gets the version of the firmware.

Example: SYST:CODE:VERS?

Response: 1.10 The version of firmware is 1.10.

SYSTem:COMM:SER:BAUD [baud]

Sets the baud rate of the serial interface.

Parameters: baud = 1200, 2400, 4800, 9600, 19200, 38400 (Default = 2400)

Example: SYST:COMM:BAUD 2400 Sets the baud rate of the serial interface to 2400.

SYSTem:COMM:SER:BAUD?

Gets the baud rate of the serial interface.

Example: SYST:COMM:BAUD?

Response: 1200 The baud rate of the serial interface is set to 1200.

SYSTem:COMM:SER:LIN [n]

Sets the use of a line feed character at the end of data sent out the serial interface.

Parameters: n = ON or 1 Turn on line feed character.
 OFF or 0 Turn off line feed character. (Default)

Example: SYST:COMM:SER:LIN 1 Turn on line feed character.

SYSTem:COMM:SER:LIN?

Gets the use of a line feed character at the end of data sent out the serial interface.

Example: SYST:COMM:SER:LIN?

Response: 0 Line feed character is not used at the end of data form the serial interface.

SYSTem:DATE <date>

Sets the system date.

Parameters: date = yyyy, mm, dd yyy = four digit number for year, mm = two digit number for month, dd = two digit number for day.

Example: SYST:DATE 2012, 05, 24 Sets the system date to May 24, 2012.

SYSTem:DATE?

Gets the system date.

Example: SYST:DATE?

Response: 2012, 11, 30 The system date is set to November 30, 2012.

SYSTem:DEC:FORM [n]

Sets the decimal format.

Parameters: n = 0 – period (Default)
 1 – comma

Example: SYST:DEC:FORM 1 Sets the decimal format to comma.

SYSTem:DEC:FORM?

Gets the decimal format.

Example: SYST:DEC:FORM?

Response: 0 Decimal format is set to period.

SYSTem:KLOC <n>

Sets the status of the front-panel keypad lock.

Note

This command has password protection. Use the SYST:PASS:CEN command first before you use this command to set this value.

Parameters: n = 1 – Lock keypad.
 0 – Unlock keypad. (Default)

Example: SYST:KLOC 1 Locks the keyboard.

SYSTem:KLOC?

Gets the status of the front-panel keypad lock.

Example: SYST:KLOC?

Response: 0 Keypad is unlocked.

SYSTem:LANG <lang>

Sets the display language.

Parameters: lang = 1 – English
 7 – Chinese

Example: SYST:LANG 7 Sets the display language to Chinese.

SYSTem:LANG?

Gets the display language.

Example: SYST:LANG?

Response: 1 The display language is set to English.

SYSTem:PASS:CDIS

Disable access to commands with password protection.

Example: SYST:PASS:CDIS

This command has no response.

SYSTem:PASS:CEN [n]

Enables access to commands with password protection.

Parameters: n = 0000 to 9999. If the n parameter is left out, then the default password of 1234 is used.

Example: SYST:PASS:CEN 1045 Disables password protection on commands where a password is necessary to set them. Password protection remains disabled until SYST:PASS:CDIS is used or you turn off power to the Product.

This command has no response.

SYSTem:PASS:CEN:STAT?

Gets the access state of password protected commands.

Example: SYST:PASS:CEN:STAT?

Response: 0 Cannot change commands with password protection. A response of 1 means password commands can be set by the applicable command. Use the SYST:PASS:CEN command to set the password protection parameter.

SYSTem:PASS:NEW <n>|DEF

Sets the system password.

Note

This command has password protection. Use the SYST:PASS:CEN command first before you use this command to set this value.

Parameters: n = 0000 to 9999

DEF Sets the password to 1234.

Example: SYST:PASS:NEW 1045 Sets the password to 1045.

This command has no response.

SYSTem:PASS:PROT <n>

Sets the password protection level.

Parameters: n = 0 – Low
1 – High

Example: SYST:PASS:PROT 1 Sets the password protection level to high.

SYST:PASS:PROT?

Gets the password protection level.

Example: SYST:PASS:PROT?

Response: 0 The password protection level is low.

UNIT:TEMP [n]

Sets the display temperature units.

Parameters: n = C – Centigrade (Default)
F - Fahrenheit

Example: UNIT:TEMP C Sets the display temperature units to Centigrade.

UNIT:TEMP?

Gets the display temperature units.

Example: UNIT:TEMP?

Response: F Display temperature units is set to Fahrenheit.

Maintenance

⚠️⚠️ Warning

To prevent possible electrical shock, fire, or personal injury:

- Do not operate the Product with covers removed or the case open. Hazardous voltage exposure is possible.
- Use only specified replacement parts.
- Have an approved technician repair the Product.

⚠️ Caution

To prevent possible damage to the Product:

- Do not use fluids to clean the well.
- Do not use harsh chemicals on the Product surfaces.
- Do an over-temperature cutout test a minimum of one time in a 6 month period.
- Make sure the well is clean and clear of unwanted material.
- Use the National Safety Council decontamination steps when hazardous material is spilt on or in the Product.

- Never introduce any foreign material into the probe hole of the Isothermal Block. Fluids, etc., can leak into the instrument causing damage.
- Do not lift or move this instrument with the isothermal block in place. The isothermal block and rear plug may fall out of the Product.

Fluke Calibration recommends that you do an axial uniformity test when you receive the Product and at 6 month intervals. See the Furnace Calibration section.

Cutout Test

Fluke Calibration recommends you do a minimum of one cutout test in 6 months. To do a cutout test:

1. Push **SET PT**.
2. Set the setpoint temperature to 400 °C and let the furnace temperature become stable.
3. Push **ENTER**.
4. Push **MENU**.
5. Push the softkey below **TEMP SETUP**.
6. Push the softkey below **CUTOUT**.
7. Set the soft cutout to 300 °C.

The cutout indicator on the front panel illuminates and the furnace stops the heat cycle. If the cutout does not stop the heat cycle, the Product must be repaired.

8. Set the soft cutout temperature to 1240 °C.

How to Clean the Product

Clean the Product surfaces with a damp cloth and mild detergent. Make sure liquids do not go into the Product.

Note

Before you clean or decontaminate the Product with a procedure not recommended by Fluke Calibration, speak with a service center associate for more information.

Furnace Calibration

The furnace calibration procedure in this manual is a general guideline. Each calibration laboratory must write a procedure for their calibration equipment and quality program. Do an uncertainty analysis with the laboratory equipment and environment.

Note

To get answers to furnace calibration questions, talk to a Fluke Calibration associate. See the How to Contact Fluke section.

Warning

To prevent possible electrical shock, fire, or personal injury, have an approved technician calibrate the Product.

A technician who does the furnace calibration procedure must know the data in this manual.

Calibration Terminology

As Found Data: Data measured on the UUT before it is adjusted.

As Left Data: Data measured on the UUT after it is adjusted.

Environment Conditions

Furnace calibration must be done in an environment with a temperature of 23 °C ±4 °C and relative humidity below 60 %.

Calibration Equipment

Table 6 is a list of equipment necessary for a furnace calibration.

Table 6. Calibration Equipment

Equipment	Specifications
Ice Point	0.05 °C accuracy 0.02 °C stability
Thermocouple Readout	0.25 °C accuracy
Thermocouples	S or R type 1 °C @ 1200 °C

Calibration

Product calibration uses a stability test, uniformity test, and adjustment, followed by an accuracy test and adjustment. All tests and adjustments are done at different temperatures across the range of the Product. Figure 24 is a flow chart of the calibration procedure for the tube furnace.

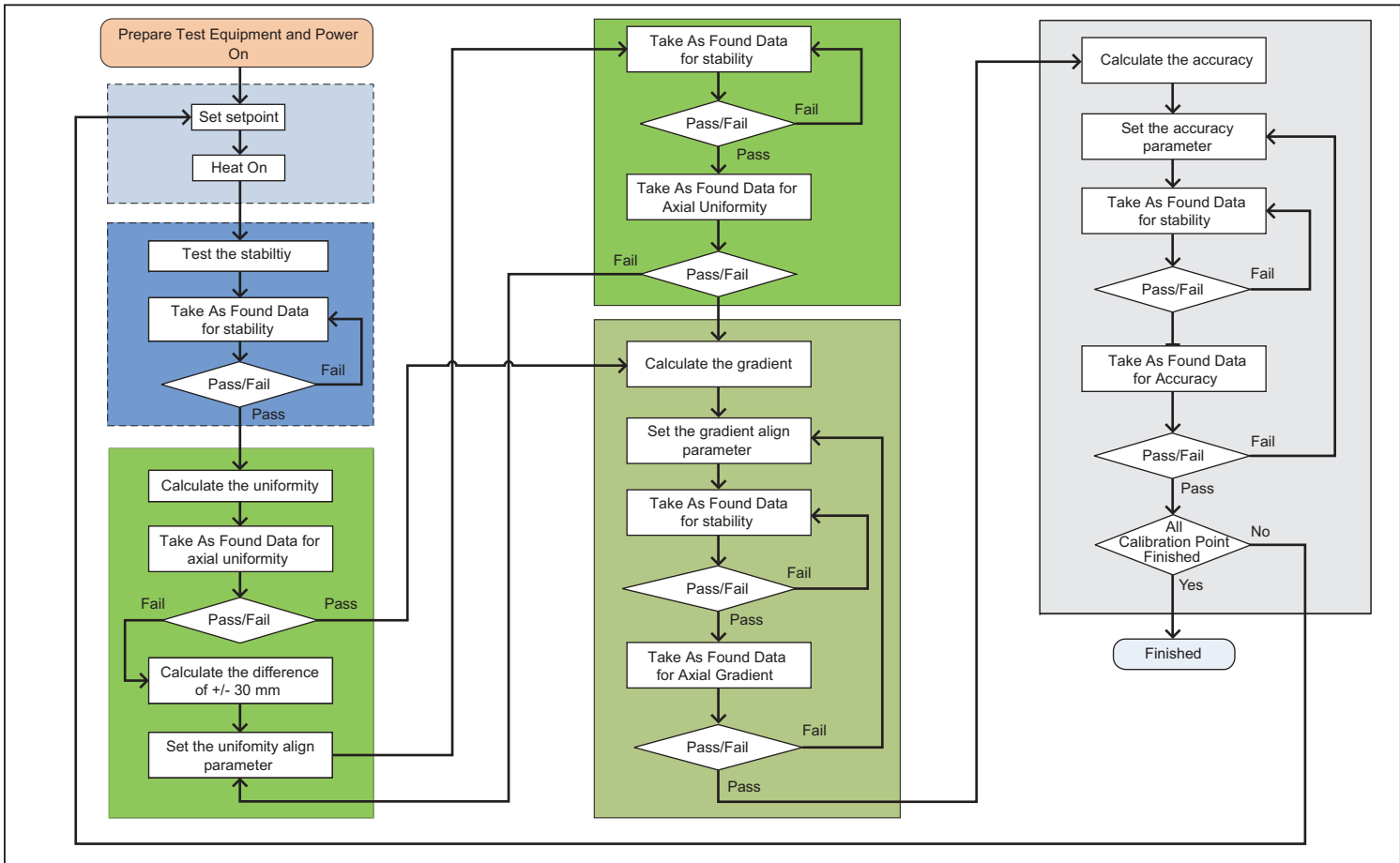

gxs114.eps

Figure 24. Tube Furnace Calibration Flow Chart

Table 7 is a list of Furnace calibration tests and adjustments.

Table 7. Furnace Calibration Tests and Adjustments

No.	Test Name	Test Points (°C)	Notes
1	Stability Test	300, 700, 1000, 1200	As Found/As Left data to verify the temperature stability – can be done with other tests at same nominal setpoints.
2	Axial Uniformity Test	300, 700, 1000, 1200	As Found data – use data for initial uniformity adjustment
3	Axial Uniformity Adjustment	300, 700, 1000, 1200	Adjust the zone and skew parameters to set axial uniformity to the specification
4	Axial Uniformity Test	300, 700, 1000, 1200	As Left data to verify the temperature uniformity.
5	Accuracy Test	300, 700, 1000, 1200	As Found test data – use to adjust the accuracy
6	Accuracy Adjustment	300, 700, 1000, 1200	Adjusts the TEMP calibration parameters to set the accuracy to the specification
7	Accuracy Test	300, 700, 1000, 1200	As Left data to verify the accuracy

Calibration Procedure for Tube Furnace

Caution

The Product can be used with or without an isothermal block installed. Unique calibration parameters are necessary for each mode of operation. To prevent Product damage, before using the Product, select the correct mode of operation in the calibration menu (see Furnace Setup Menu). If necessary, a calibration for the new mode of operation may be required.

1. Connect the test equipment as shown in Figure 25.

Note

In the steps that follow, start the calibration procedure at the lowest temperature (300 °C) and move up the range to 1200 °C.

2. Set the Product to one of the setpoint temperatures in Table 8.

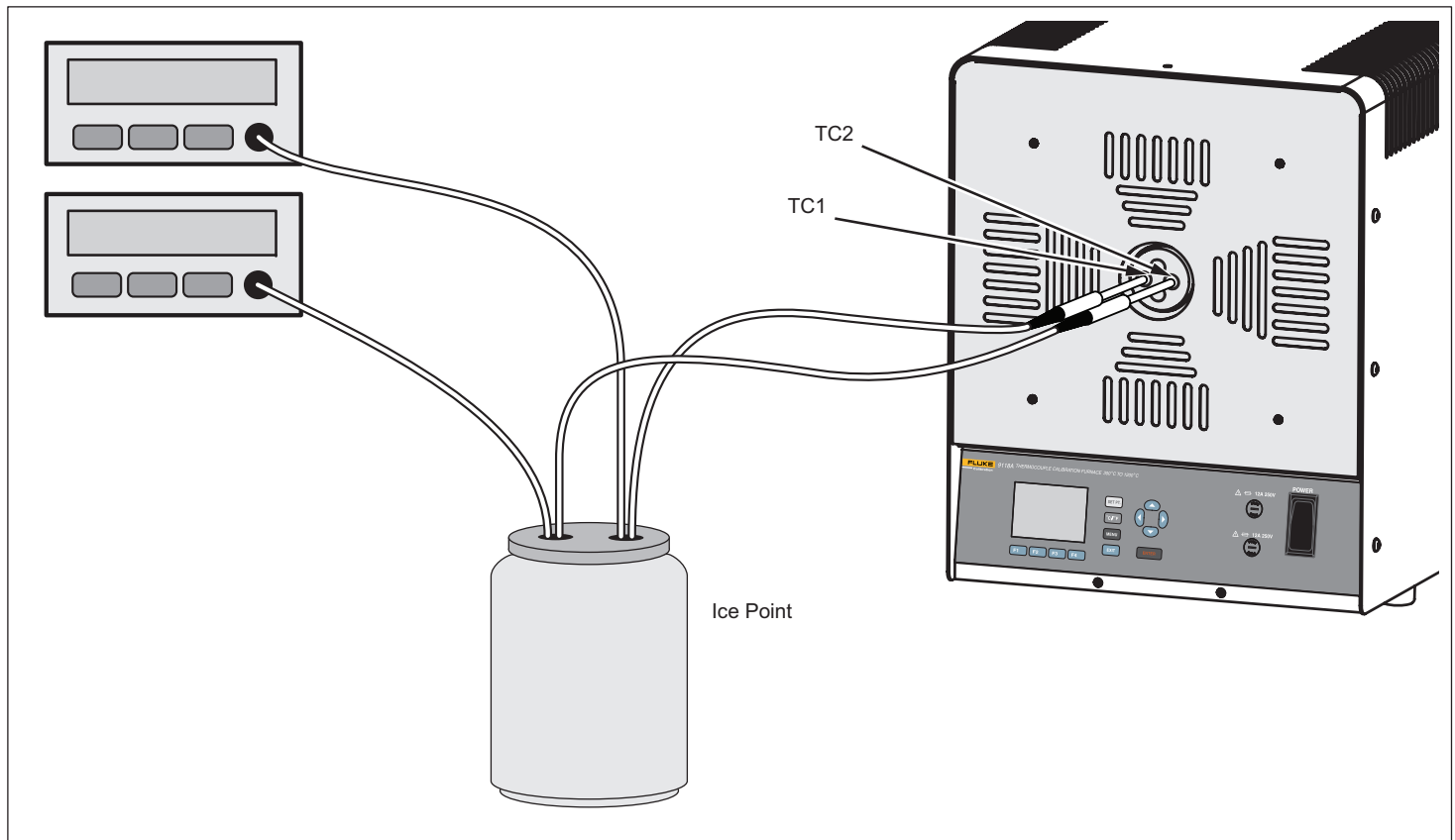

gxs120.eps

Figure 25. Test Equipment Connections

Stability Test

The 7 steps that follow find the As Found and As Left data for stability.

3. Push **ENTER** to start the furnace.
4. Put the test thermocouple (TC1) at the center of the furnace (zero reference).
5. Stabilization time starts after one hour when the stability indicator shows the furnace temperature is stable.
6. After the stabilization time, record the temperature on the readout for TC1 at 1 minute intervals for 30 minutes.
7. Calculate 2σ (2 times the standard deviation) of the 30 recorded measurements.
8. Compare the calculated 2σ with the value in the stability column of Table 8.

Table 8. Stability Test Data

Setpoint (°C)	Stabilization Time (min)	Samples	Stability 2σ Limit ($\pm^\circ\text{C}$)
300	60	30	0.2
700	60	30	0.2
1000	60	30	0.2
1200	60	30	0.2

If the test fails, do steps 6 through 8 again. If it fails a second time, repair the instability.

9. Record the result.

Axial Uniformity

The steps that follow make up the axial uniformity test and the formulae to calculate the SKEW and ZONE parameter values. The new values are put into the Product to correct for axial temperature gradients.

Note

The axial uniformity test must be done before the axial uniformity adjustment.

10. Move test thermocouple TC2 to one of the positions shown in Table 9.
11. Let the thermocouple soak for a minimum of 5 minutes at this position.
12. Record the temperature for TC1 and TC2 in Table 9.

13. Do steps 10 through 12 again for each position in Table 9.

Note

Let the Product soak for 5 minutes after you move TC2.

Table 9. Axial Uniformity Test

	TC2 Position from Furnace Center (mm)				
	-30	-10	0	10	30
TC1					
TC2					
Difference					

14. Calculate the temperature difference relative to the center position for each position of TC2 in Table 9. and record it in the table.

$$Difference_{(x)} = (TC2_{(x)} - TC1_{(x)}) - (TC2_{(0)} - TC1_{(0)})$$

15. Calculate a gradient value for the 30 and -30 positions of TC2 with:

$$Gradient_{(x)} = TC2_{(x)} - TC1_{(x)}$$

X = TC2 Position at 30 mm and -30 mm

16. Calculate the slope value with:

$$Slope = Gradient_{(+30)} - Gradient_{(-30)}$$

17. Calculate the SKEW value with:

$$SKEW_{n(new)} = SKEW_{n(old)} + A \times (Slope)$$

18. Table 10 shows the value for A at each of the temperature setpoints.

Table 10. Skew Correction Values

Setpoint (°C)	A Value
300	1.02
700	1.35
1000	4.67
1200	5.30

19. Put the $SKEW_{n(new)}$ value into the Product through the front panel or RS-232 port. Table 11 is a list of temperature setpoints and the RS-232 command and front-panel name for the SKEW parameters.

Table 11. SKEW Parameter

Setpoint (°C)	Parameter	
	RS-232 Command	Front Panel
300	SOUR:SENS:CAL:SKEW1	SKEW (300)
700	SOUR:SENS:CAL:SKEW2	SKEW (700)
1000	SOUR:SENS:CAL:SKEW3	SKEW (1000)
1200	SOUR:SENS:CAL:SKEW4	SKEW (1200)

20. Let the Product soak for 60 minutes after you put in the SKEW value.

21. Do steps 10 through 13 again to make sure axial uniformity is equal to or less than the specification. The difference between the maximum and minimum values in the difference row of Table 9 must be between ± 0.5 °C.
22. Calculate a curve value for the 0, 30 and -30 positions of TC2 with:

$$\text{Curve} = \frac{(\text{Gradient}_{(0)} - \text{Gradient}_{(+30)}) + (\text{Gradient}_{(0)} - \text{Gradient}_{(-30)})}{2}$$

23. Calculate the ZONE value with:

$$\text{ZONE}_{n(\text{new})} = \text{ZONE}_{n(\text{old})} + B \times (\text{Curve})$$

Table 12 shows the value for B at each temperature setpoint.

Table 12. Zone Correction Values

Setpoint	B Value
300	1.5
700	2.4
1000	3.3
1200	4.2

24. Put the $\text{ZONE}_{n(\text{new})}$ value into the Product through the front panel or RS-232 port. Table 13 a list of temperature setpoints and the RS-232 command and front-panel name for the ZONE parameters.

Table 13. ZONE Parameter

Setpoint (°C)	Parameter	
	RS-232 Command	Front Panel
300	SOUR:SENS:CAL:ZONE1	ZONE (300)
700	SOUR:SENS:CAL:ZONE2	ZONE (700)
1000	SOUR:SENS:CAL:ZONE3	ZONE (1000)
1200	SOUR:SENS:CAL:ZONE4	ZONE (1200)

25. Let the Product soak for 60 minutes after you put in the ZONE value.
26. Do steps 10 through 14 again to make sure axial uniformity is equal to or less than the specification. If the Product does not satisfy the specification, do steps 15 through 25 again with the new axial uniformity values.

Accuracy Test

Note

Make sure TC1 is at the midpoint in the access tube (0 MM) when you do an accuracy test.

To do an accuracy test:

1. Set the Product to a setpoint temperature in Table 14.
2. Wait for the stability indicator to show the furnace temperature is stable.
3. Record TC1 measurements for 1 minute.
4. Calculate the average of all measurements.
5. Calculate accuracy with:

$$\text{Accuracy} = TC1 - \text{setpoint temperature}$$
6. The accuracy must be less than or equal to ± 5 °C. If not, do an accuracy adjustment.
7. Do steps 1 through 6 for each setpoint temperature in Table 14.

Accuracy Adjustment

To do an accuracy adjustment:

1. Calculate the new $TEMP_n$ parameter with:

$$Temp_{n(new)} = Temp_{n(old)} - \text{Accuracy}$$
2. Put the $TEMP_{n(new)}$ value into the Product through the front panel or RS-232 port. Table 14 is a list of temperature setpoints and the RS-232 command and front-panel name for the TEMP parameters.

Table 14. Accuracy Parameter

Setpoint (°C)	Parameter	
	RS-232 Command	Front Panel
300	SOUR:SENS:CAL:PAR1	TEMP (300)
700	SOUR:SENS:CAL:PAR2	TEMP (700)
1000	SOUR:SENS:CAL:PAR3	TEMP (1000)
1200	SOUR:SENS:CAL:PAR4	TEMP (1200)

3. Let the Product soak for 60 minutes after you put in the TEMP value.
4. Do steps 1 through 6 of the accuracy test.

To complete the calibration of the Product, do a stability test, axial uniformity test, and accuracy test to make sure the Product is equal to or less than the specifications for each setpoint.

Calibration procedure for 9118A-ITB (with Isothermal Block)

⚠ Caution

The furnace can be used with or without an isothermal block installed. Unique calibration parameters are necessary for each mode of operation. To prevent damage to the Product, before Product use, select the appropriate mode of operation in the calibration menu (see Furnace Setup Menu). When the mode of operation is changed, a calibration for the new mode of operation may be required.

Figure 27 shows a brief overview of the calibration procedure with a thermo block.

Calibration Equipment Setup

1. Mark scales on TC1 and TC2 as shown in Figure 26. Scale interval is 10 mm.
2. Connect equipment as shown in Figure 25.
3. Put TC1 and TC2 in the position of 0 and 60 as shown in Figure 26.

Note

In the steps that follow, start the calibration procedure at the lowest temperature (300 °C) and move up the range to 1200 °C. Set the Product to one of the setpoint temperatures in Table 15.

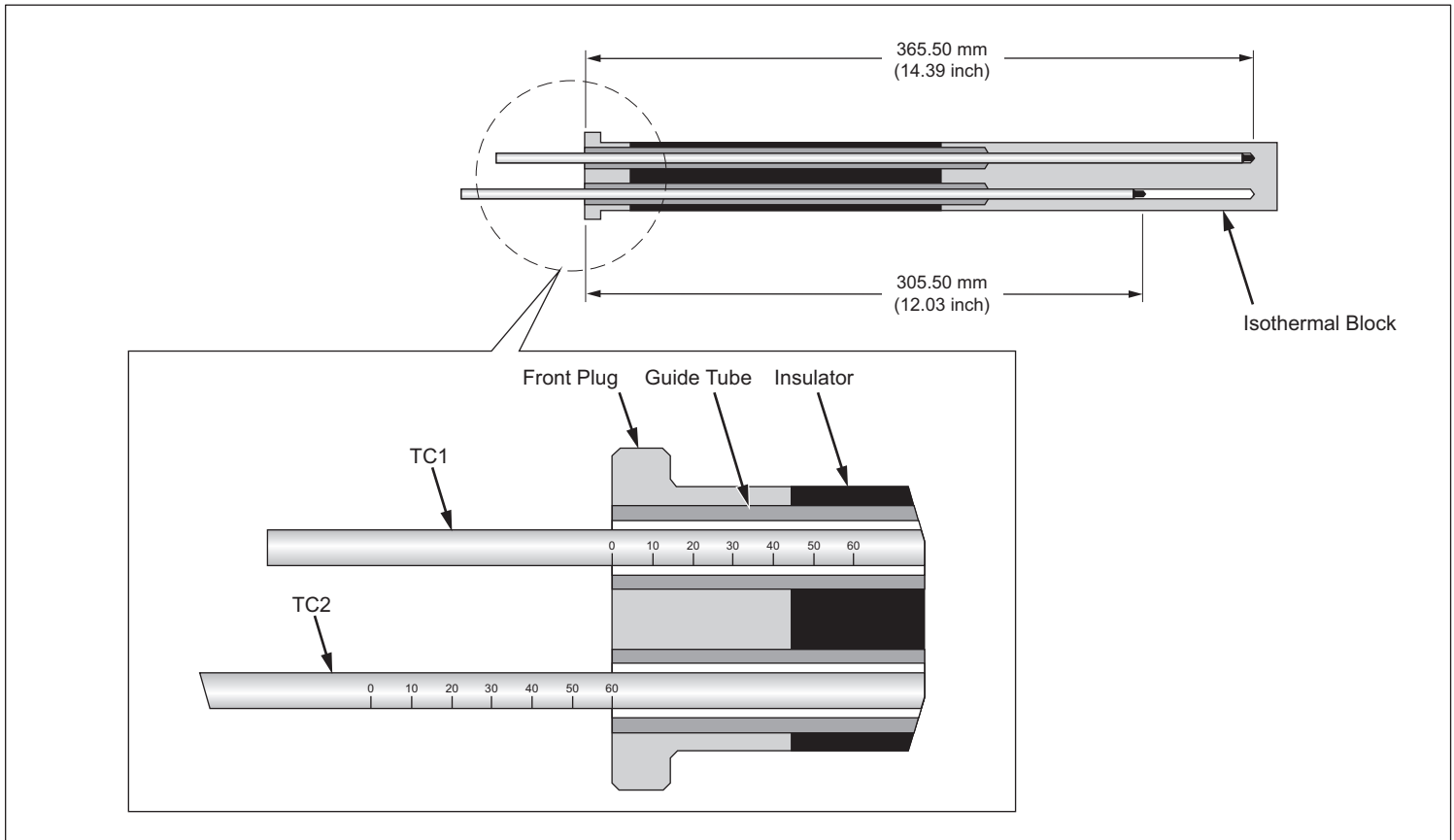
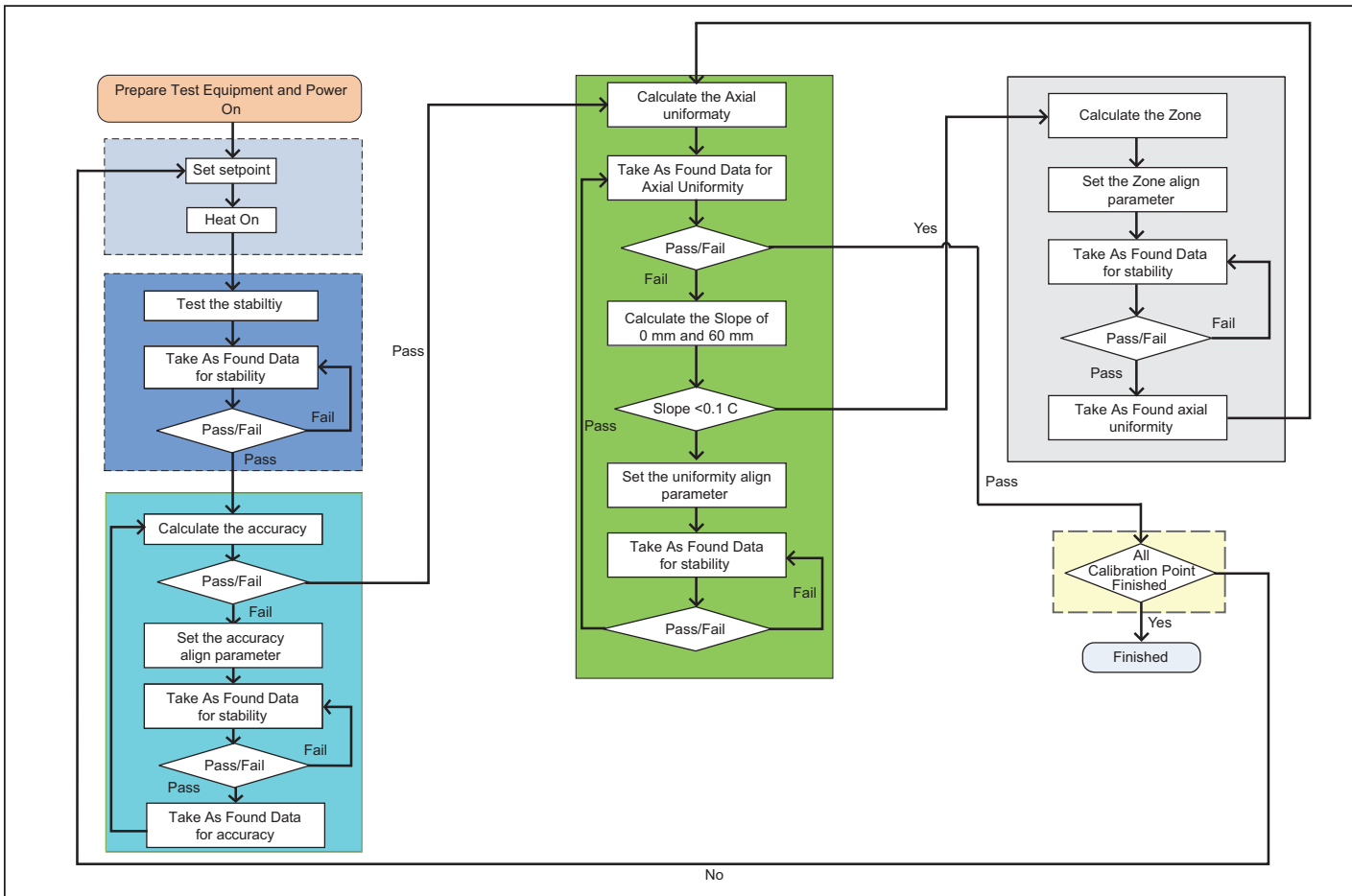

Figure 26. Calibration Equipment Setup

gxs134.eps



gxs135.eps

Figure 27. Calibration Procedure for Furnace with Thermo Block

Stability Test

The steps that follow find the As Found and As Left data for stability.

1. Push **ENTER** to start the furnace.
2. Put TC1 at 0 mm and TC2 at 60 mm.
3. Stabilization time starts after one hour when the stability indicator shows the furnace temperature is stable.
4. After the stabilization time, record the temperature on the readout for TC1 at 1-minute intervals for 30 minutes.
5. Calculate 2σ (2 times the standard deviation) of the 30 recorded measurements.
6. Compare the calculated 2σ with the value in the stability column of Table 15.

Table 15. Stability Test Data with Isothermal block

Setpoint (°C)	Stabilization Time (min)	Samples	Stability 2σ Limit (\pm °C)
300	60	30	0.1
700	60	30	0.1
1000	60	30	0.1
1200	60	30	0.1

If the test fails, do steps 4 through 6 again. If it fails a second time, repair the instability.

7. Record the result.

After the stability of the set temperature is verified, it is recommended that you do the accuracy test that follows.

Accuracy Test

Note

When you do an accuracy test, make sure TC1 is at 0 mm inside isothermal block

To do an accuracy test:

1. Set the Product to a setpoint temperature in Table 16.
2. Wait for the furnace temperature to become stable.

Note

Use the "Stability Test" above to judge if the furnace is stable.

3. Record TC1 measurements for 1 minute.
4. Calculate the average of all measurements.
5. Calculate accuracy with:

$$\text{Accuracy} = \text{TC1} - \text{setpoint temperature}$$
6. The accuracy must be $\leq \pm 5$ °C. If not, do an accuracy adjustment.
7. Do steps 1 through 6 until the accuracy is $\leq \pm 5$ °C.

Accuracy Adjustment

To do an accuracy adjustment:

1. Calculate the new TEMP_n parameter with:
$$\text{Temp}_n(\text{new}) = \text{Temp}_n(\text{old}) - \text{Accuracy}$$
2. Put the Temp_n (new) value into the Product through the front panel or RS-232 port. Table 16 is a list of temperature setpoints and the RS-232 command and front-panel name for the TEMP parameters.

Table 16. Accuracy Parameter for Isothermal Block

Setpoint (°C)	Parameter	
	RS-232 Command	Front Panel
300	SOUR:SENS:CAL:PAR1	TEMP (300)
700	SOUR:SENS:CAL:PAR2	TEMP (700)
1000	SOUR:SENS:CAL:PAR3	TEMP (1000)
1200	SOUR:SENS:CAL:PAR4	TEMP (1200)

3. After you put in the TEMP value, let the Product soak for 60 minutes.
4. Do steps 1 through 6 of the Accuracy Test.

After the accuracy is verified or adjusted, it is recommended that you do the axial uniformity verification and adjustment that follows.

Axial Uniformity

The steps that follow make up the axial uniformity test and the formulae to calculate the SKEW and ZONE parameter values. The new values are put into the Product to correct for axial temperature gradients.

Note

The axial uniformity test must be done before the axial uniformity adjustment.

1. Respectively, move TC2 to one of the positions shown in Table 17. TC1 is always fixed at the position 0 mm as a reference in the period of moving TC2 at different locations.
2. Let TC2 soak for a minimum of 5 minutes at this position.
3. Record the temperature for TC1 and TC2 in below Table 17.

Table 17. Axial Uniformity Test with Isothermal Block

	60 mm	50 mm	40 mm	30 mm	20 mm	10 mm	0 mm
TC1(fixed @0 mm)							
TC2(test in each position from 60 mm to 0 mm)							
Difference(x), x=60,50,40,...,0 mm							

4. Do steps 1 through 3 again for each position in Table 17.

Note

After you move TC2, let the Product soak for 5 minutes.

5. Calculate the temperature difference relative to the 0 mm position for each position of TC2 in Table 17 and record it in the table.

$$\text{Difference}(x) = (TC2(x) - TC1(x)) - (TC2(0) - TC1(0))$$

$X=0, 10, \dots, 60\text{mm}$

$$\text{Difference-p} = \text{Max}(\text{Difference}(0), \text{Difference}(10), \dots, \text{Difference}(60)) - \text{Min}(\text{Difference}(0), \text{Difference}(10), \dots, \text{Difference}(60))$$

Note

If the Difference-p already meets the axial uniformity tolerances, it is not necessary to make further adjustments to the SKEW and ZONE calibration values.

6. Calculate a gradient value for the 0 mm and 60 mm positions of TC2 with:

$$\text{Gradient}(x) = TC2(x) - TC1(x)$$

X = Position at 0 mm and 60 mm

7. Calculate the slope value with:

$$\text{Slope} = \text{Gradient}(60) - \text{Gradient}(0)$$

8. Calculate the SKEW value with:

$$\text{SKEWn}(\text{new}) = \text{SKEWn}(\text{old}) + A \times (\text{Slope})$$

9. Table 18 shows the value for A at each of the temperature setpoints.

Table 18. Skew Correction Values for Isothermal Block

Calibration Point	A value
300	0.78
700	2.14
1000	3.67
1200	4.90

10. Put the $SKEW_n(\text{new})$ value into the Product through the front panel or RS-232 port. Table 19 is a list of temperature setpoints and the RS-232 command and front-panel name for the SKEW parameters.

Table 19. SKEW Parameter for Isothermal Block

Setpoint (°C)	Parameter	
	RS-232 Command	Front Panel
300	SOUR:SENS:CAL:SKEW1	SKEW (300)
700	SOUR:SENS:CAL: SKEW 2	SKEW (700)
1000	SOUR:SENS:CAL: SKEW 3	SKEW (1000)
1200	SOUR:SENS:CAL: SKEW 4	SKEW (1200)

11. Let the Product soak for 90 minutes for the calibration points of 700 °C, 1000 °C, and 1200 °C. Let the Product soak for 180 minutes for calibration points of 300 °C after you put in the SKEW value.

12. Do steps 1 through 5 again to make sure axial uniformity is equal to or less than the specification or requirement.

Note

If the axial uniformity already meets the specification or requirement, it is not necessary to continue with the following zone adjustment. It is recommended that you do steps 6 through 12 again if the result cannot meet the specification or the necessary requirement. If the slope is <0.1 °C and the axial uniformity still cannot meet specification, then go the following zone adjustment. If the absolute value of slope of every adjustment does not show the trend of decreasing, contact an authorized Fluke Calibration Service Center.

13. Calculate a curve as the peak to peak value from the table of difference(x) from 0 mm to 60 mm. For example, the maximum value is 0.1 °C and the minimum value is -0.1 °C, then the curve is 0.2 in this case.

$$\text{Curve} = \text{Maximum}(\text{Difference}(0), \dots, \text{Difference}(60)) - \text{Minimum}(\text{Difference}(0), \dots, \text{Difference}(60))$$

14. Calculate the ZONE value with:

$$ZONEn(\text{new}) = ZONEn(\text{old}) + B \times (\text{Curve})$$

Table 20 shows the value for B at each temperature setpoint.

Table 20. Zone Correction Values For Isothermal Block

Calibration Point	B Value
300	30
700	30
1000	10
1200	10

15. Put the ZONE_n(new) value into the Product through the front panel or RS-232 port. Table 21 is a list of temperature setpoints and the RS-232 command and front-panel name for the ZONE parameters.

Table 21. Zone Parameter for Isothermal Block

Setpoint (°C)	Parameter	
	RS-232 Command	Front Panel
300	SOUR:SENS:CAL:ZONE1	SKEW (300)
700	SOUR:SENS:CAL: ZONE 2	SKEW (700)
1000	SOUR:SENS:CAL: ZONE 3	SKEW (1000)
1200	SOUR:SENS:CAL: ZONE 4	SKEW (1200)

16. Let the Product soak for 60 minutes for the calibration points of 700 °C, 1000 °C, and 1200 °C. Let the Product soak for 120 minutes for calibration points of 300 °C after you put in the ZONE value.
17. Do steps 1 through 5 again to make sure axial uniformity is equal to or less than the specification or requirement. If the Product does not satisfy the specification or requirement, do steps 6 through 16 again with the new axial uniformity values.

To complete the calibration of the Product, do a stability test, axial uniformity test, and accuracy test to make sure the Product is equal to or less than the specifications for each setpoint.

Specifications for 9118A and 9118A-ITB

General Specifications

Operating Conditions

Operating Temperature	5 °C to 40 °C
Storage Temperature.....	-20 °C to 70 °C
Humidity.....	80 % maximum for temperatures <31 °C, decreasing linearly to 50 % at 40 °C
Altitude.....	<2000 m
Power Requirements	230 V ac (±10 %), 50/60 Hz, 20 A
Heater Power.....	4000 watts at 230 V ac

Over-current Protection

System.....	20 A, 250 V resettable circuit breaker
Main Heater Fuse	F 12 A, 250 V
Zone Heater Fuse.....	F 12 A, 250 V
Computer Interface	RS-232 and USB
Display	Monochrome LCD, °C or °F user-selectable
Display Resolution	0.1 °C or °F
Size (H x W x L).....	400 mm x 337 mm x 700 mm
Net Weight	29 kg (without isothermal block)

Isothermal Block (optional)

Isothermal Block Construction	Alumina
Block Outer Diameter	37 mm
Block Length	380 mm
Well Diameter (four wells total).....	6.7 mm
Well Depth	365 mm
Net Weight	0.84 kg (isothermal block only)

Accuracy Specifications

All accuracy specifications except temperature are for a period of 1 year after calibration, at 13 °C to 33 °C.

Note

The furnace can be used with or without an isothermal block installed. Unique calibration parameters are necessary for each configuration. Calibration does NOT come standard from the factory for each configuration. Ensure that the furnace has been properly calibrated for the desired mode of operation.

Furnace Temperature Range300 °C to 1200 °C

Set-Point Accuracy±5 °C

Radial Uniformity

Temperature	9118A (14 mm from geometry central point)	9118A-ITB (hole to hole)
300 °C	±0.5 °C	±0.1 °C
700 °C		±0.20 °C
1200 °C		±0.25 °C

Axial Uniformity

Temperature	9118A (±30 mm axial length from geometry central point)	9118A-ITB (at 60 mm from full immersion)
Full Range	±0.25 °C	±0.2 °C

Temperature Stability

Specification	9118A	9118A-ITB
Stability	±0.2 °C	±0.1 °C
Stabilization Time	2 hours, full range	3 hours at or below 700 °C 2 hours above 700 °C

Note: Temperature stability measured as 2-sigma over 30 minutes

Heating Time (23 °C to 1200 °C)

9118A	40 minutes
9118A-ITB.....	45 minutes

Cooling Time (1200 °C to 300 °C)

9118A	180 minutes
9118A-ITB.....	200 minutes