

# Technical Information

## iTEMP TMT162

Dual input temperature field transmitter

**HIGHLY CONFIGURABLE** - Let Transcat Help build your Endress+Hauser Instrument  
Call: **1.800.828.1470** or email **sales@transcat.com**

**TRANSCAT**<sup>®</sup>  
Trust in every measure

Visit us at [Transcat.com](http://Transcat.com) ▶



with HART<sup>®</sup>, FOUNDATION Fieldbus<sup>™</sup> or PROFIBUS<sup>®</sup> PA protocol

### Application

- Universal input for resistance thermometer (RTD), thermocouple (TC), resistance transmitter ( $\Omega$ ), voltage transmitter (mV)
- Output:
  - HART<sup>®</sup> protocol for converting different input signals to a scalable 4 to 20 mA analog output signal. Transmitter can be operated via the handheld terminals Field Xpert SFX100, DXR275/375/475 or via a PC
  - FOUNDATION Fieldbus<sup>™</sup> ITK 6.1.2
  - PROFIBUS<sup>®</sup> PA Profile 3.02

### Your benefits

- Extremely reliable in harsh industrial environments thanks to dual-compartment housing and compact, fully encapsulated electronics
- Backlit display with large display of measured value, bar graph and status
- Two sensor inputs
- Diagnostics information according to NAMUR NE107
- Reliable operation thanks to sensor monitoring: failure information, sensor backup, drift alarm and corrosion detection
- International approvals such as FM, CSA (IS, NI, XP and DIP) and ATEX (Ex ia, Ex nA nL, Ex d and dust ignition-proof)
- Galvanic isolation 2 kV (sensor input/output)

## Function and system design

### Measuring principle

Electronic monitoring, conversion and display of input signals used in industrial temperature measurement.

### Measuring system

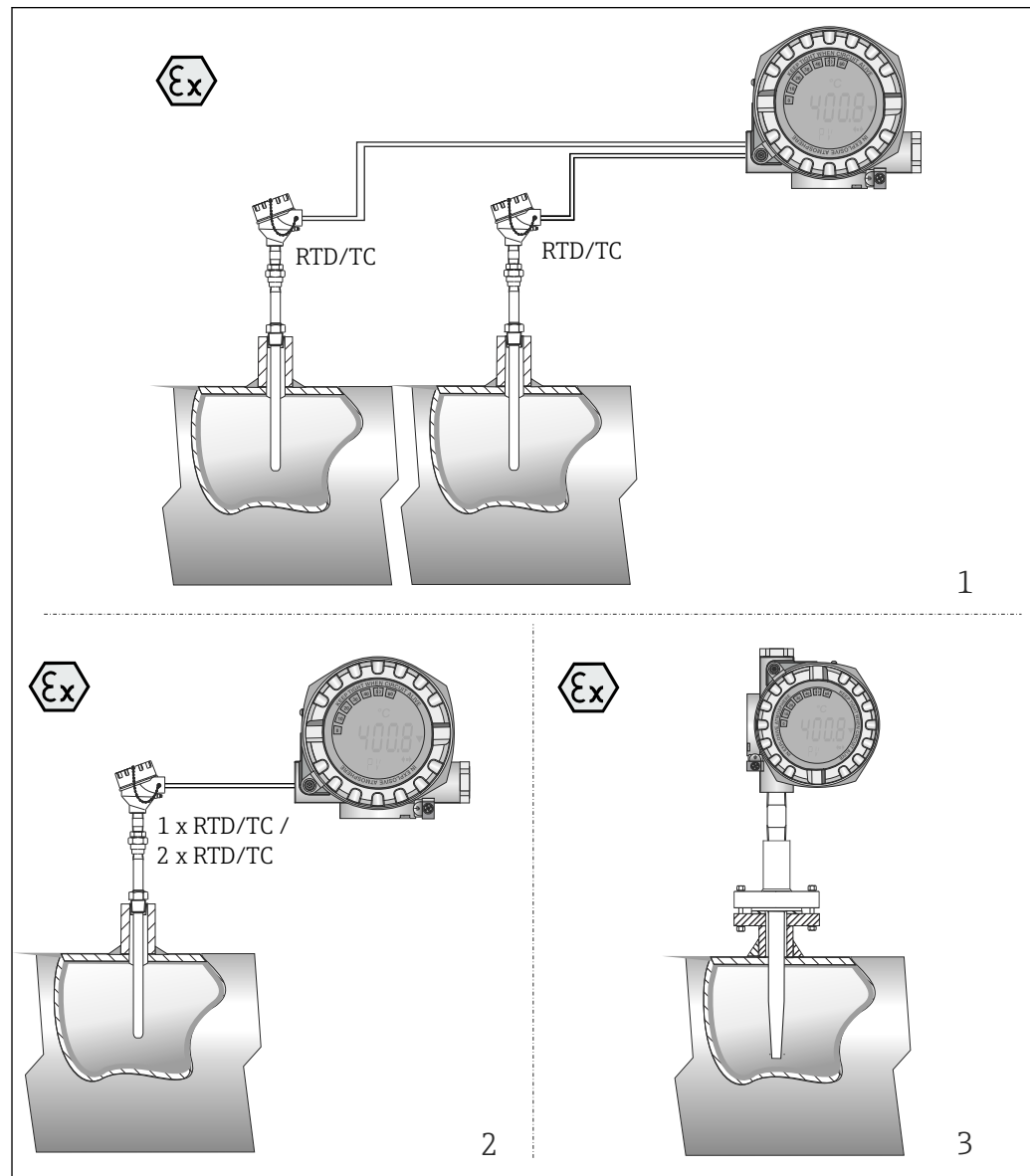

#### 1 Application examples

- Two sensors with measuring input (RTD or TC) in remote installation with the following advantages: drift warning, sensor backup function and temperature-dependent sensor switching
- 1 x RTD/TC or 2 x RTD/TC for redundancy
- Temperature field transmitter in combination with a sensing element, insert and thermowell as compact thermometer

The iTEMP temperature field transmitter TMT162 is a two-wire transmitter with an analog output or fieldbus protocol, two (optional) measuring inputs for resistance thermometers and resistance transmitters in 2-, 3- or 4-wire connection (for a resistance measuring input), thermocouples and voltage transmitters. The LC display shows the current measured value digitally and as a bar graph and also indicates the current status of the device.

**Standard diagnostic functions**

- Cable open circuit, short-circuit
- Incorrect wiring
- Internal device errors
- Overrange/underrange detection
- Ambient temperature out-of-range detection

**Corrosion detection as per NAMUR NE89**

Corrosion of the sensor connection cables can cause incorrect measured value readings. The field transmitter offers the possibility of detecting corrosion on thermocouples and resistance thermometers with a 4-wire connection before measured value corruption occurs. The transmitter prevents incorrect readings of measured values and can issue a warning on the display as well as through the HART® or fieldbus protocol if wire resistance values exceed plausible limits.

**Low voltage detection for HART® communication**

The low voltage detection function prevents the device from continuously outputting an incorrect analog output value (i.e. due to a damaged or incorrect power supply or due to a damaged signal cable). If the supply voltage drops below the required value, the analog output value drops to < 3.6 mA for approx. 3 s. An error message is displayed. The device then tries to output the normal analog output value again. If the supply voltage is still too low, the analog output value drops again to < 3.6 mA.

**Optional dual input functions**

These functions increase the reliability and availability of the process values:

- Sensor backup : If sensor 1 fails, the output signal is switched without interruption to the measured value of sensor 2.
- Temperature-dependent sensor switching: The measured value is recorded by sensor 1 or 2 depending on the process temperature.
- Sensor drift detection: If both measured values of sensor 1 and 2 deviate from a specified value, a drift warning or alarm is output.

**Equipment architecture**

Analog current output 4 to 20 mA with HART® protocol

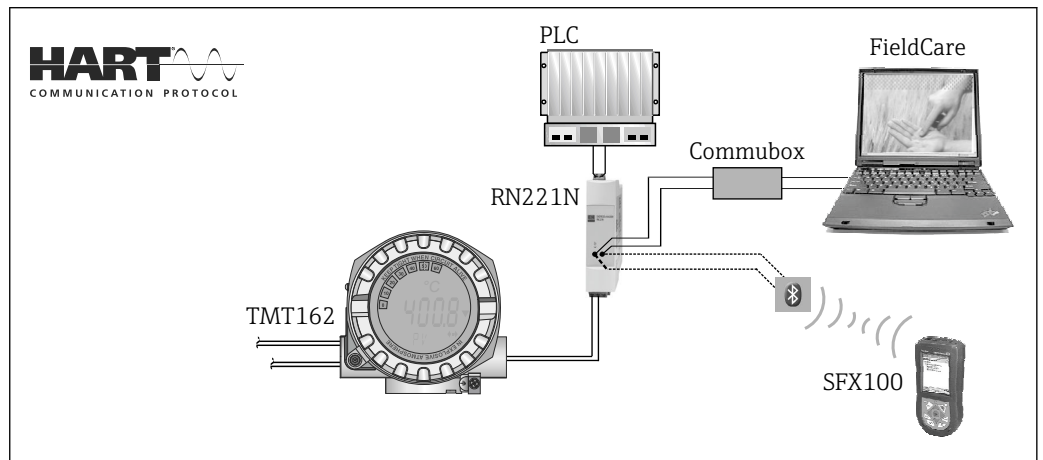

A0014375

System integration via FOUNDATION Fieldbus™

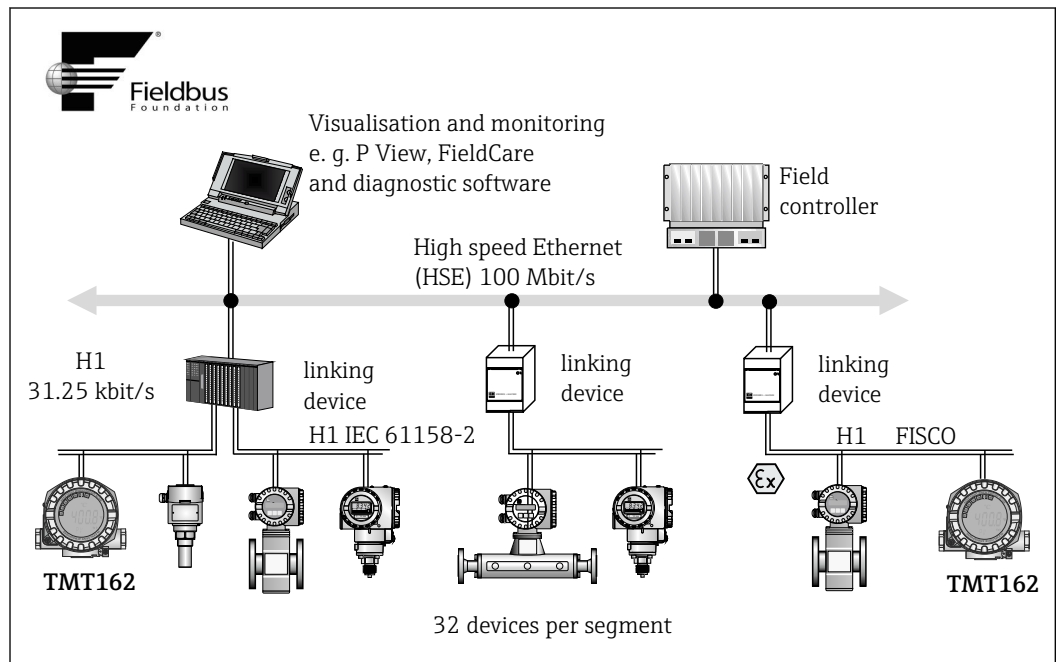

System integration via PROFIBUS® PA

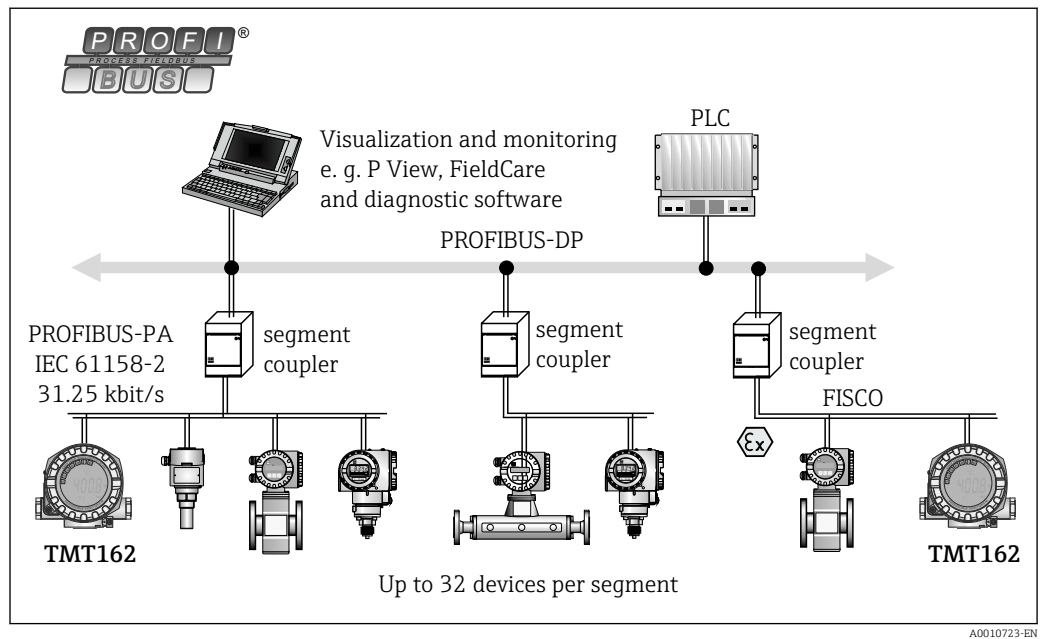

## Input

**Measured variable**                      Temperature (temperature-linear transmission behavior), resistance and voltage.

Resistance thermometer (RTD) as per standard	Designation	$\alpha$	Measuring range limits	Min. span
IEC 60751:2008	Pt100 Pt200 Pt500 Pt1000	0.003851	-200 to +850 °C (-328 to +1562 °F) -200 to +850 °C (-328 to +1562 °F) -200 to +500 °C (-328 to +932 °F) -200 to +250 °C (-328 to +482 °F)	10 K (18 °F)
JIS C1604:1984	Pt100	0.003916	-200 to +510 °C (-328 to +950 °F)	10 K (18 °F)
SAMA	Pt100	0.003923	-100 to +700 °C (-148 to +1292 °F)	10 K (18 °F)
DIN 43760 IPTS-68	Ni100 Ni120 Ni1000	0.006180	-60 to +250 °C (-76 to +482 °F) -60 to +250 °C (-76 to +482 °F) -60 to +150 °C (-76 to +302 °F)	10 K (18 °F)
GOST 6651-94	Pt50 Pt100	0.003910	-185 to +1100 °C (-301 to +2012 °F) -200 to +850 °C (-328 to +1562 °F)	10 K (18 °F)
Edison Copper Winding No. 15	Cu10		-100 to +260 °C (-148 to +500 °F)	10 K (18 °F)
OIML R84: 2003, GOST 6651-2009	Cu50 Cu100	0.004280	-175 to +200 °C (-283 to +392 °F) -180 to +200 °C (-292 to +392 °F)	10 K (18 °F)
	Ni100 Ni120	0.006170	-60 to +180 °C (-76 to +356 °F) -60 to +180 °C (-76 to +356 °F)	10 K (18 °F)
OIML R84: 2003, GOST 6651-94	Cu50	0.004260	-50 to +200 °C (-58 to +392 °F)	10 K (18 °F)
-	Pt100 (Callendar van Dusen) Nickel polynomial <b>(not for HART® protocol)</b> Copper polynomial <b>(not for HART® protocol)</b>	-	10 to 400 Ω 10 to 2 000 Ω	10 Ω 10 Ω
<ul style="list-style-type: none"> <li>▪ Type of connection: 2-wire, 3-wire or 4-wire connection, sensor current: ≤0.3 mA</li> <li>▪ With 2-wire circuit, compensation of wire resistance possible (0 to 30 Ω)</li> <li>▪ With 3-wire and 4-wire connection, sensor wire resistance up to max. 50 Ω per wire</li> </ul>				
<b>Resistance transmitter</b>	Resistance Ω		10 to 400 Ω 10 to 2 000 Ω	10 Ω 10 Ω

Thermocouples <sup>1)</sup> as per standard	Designation	Measuring range limits		Min. span
IEC 60584, Part 1	Type A (W5Re-W20Re)	0 to +2 500 °C (+32 to +4 532 °F)	Recommended temperature range: 0 to +2 500 °C (+32 to +4 532 °F)	50 K (90 °F)
	Type B (PtRh30-PtRh6) <sup>2)</sup>	+40 to +1 820 °C (+104 to +3 308 °F)	+100 to +1 500 °C (+212 to +2 732 °F)	50 K (90 °F)
	Type E (NiCr-CuNi)	-270 to +1 000 °C (-454 to +1 832 °F)	0 to +750 °C (+32 to +1 382 °F)	50 K (90 °F)
	Type J (Fe-CuNi)	-210 to +1 200 °C (-346 to +2 192 °F)	+20 to +700 °C (+68 to +1 292 °F)	50 K (90 °F)
	Type K (NiCr-Ni)	-270 to +1 372 °C (-454 to +2 501 °F)	0 to +1 100 °C (+32 to +2 012 °F)	50 K (90 °F)
	Type N (NiCrSi-NiSi)	-270 to +1 300 °C (-454 to +2 372 °F)	0 to +1 100 °C (+32 to +2 012 °F)	50 K (90 °F)
	Type R (PtRh13-Pt)	-50 to +1 768 °C (-58 to +3 214 °F)	0 to +1 400 °C (+32 to +2 552 °F)	50 K (90 °F)
	Type S (PtRh10-Pt)	-50 to +1 768 °C (-58 to +3 214 °F)	0 to +1 400 °C (+32 to +2 552 °F)	50 K (90 °F)
ASTM E988-96	Type C (W5Re-W26Re)	0 to +2 315 °C (+32 to +4 199 °F)	0 to +2 000 °C (+32 to +3 632 °F)	50 K (90 °F)
	Type D (W3Re-W25Re)	0 to +2 315 °C (+32 to +4 199 °F)	0 to +2 000 °C (+32 to +3 632 °F)	50 K (90 °F)
DIN 43710	Type L (Fe-CuNi)	-200 to +900 °C (-328 to +1 652 °F)	0 to +750 °C (+32 to +1 382 °F)	50 K (90 °F)
	Type U (Cu-CuNi)	-200 to +600 °C (-328 to +1 112 °F)	-185 to +400 °C (-301 to +752 °F)	50 K (90 °F)

Thermocouples <sup>1)</sup> as per standard	Designation	Measuring range limits	Min. span
	<ul style="list-style-type: none"> <li>▪ Internal cold junction (Pt100)</li> <li>▪ External cold junction: configurable value -40 to +85 °C (-40 to +185 °F)</li> <li>▪ Maximum sensor wire resistance 10 kΩ (if the sensor wire resistance is greater than 10 kΩ, an error message as per NAMUR NE89 is output) <sup>3)</sup></li> </ul>		
<b>Voltage transmitter (mV)</b>	Millivolt transmitter (mV)	-5 to 30 mV -20 to 100 mV	5 mV

- 1) When operating conditions are based on a large temperature range, the transmitter offers you the ability to split the range. For example, a Type S or R thermocouple can be used for the lower range and a Type B can be used for the upper range. The transmitter is then programmed by the end operator to switch at a predefined temperature. This allows for utilization of the best performance from each individual thermocouple and provides 1 output that represents the process temperature.
- 2) High measuring uncertainty for temperatures below 300 °C (572 °F)
- 3) Basic requirements of NE89: Detection of increased wire resistance (e.g. corrosion of contacts or wires) of TC or RTD/4-wire. Warning - exceeding ambient temperature.

### Type of input

The following connection combinations are possible when both sensor inputs are assigned:

		Sensor input 1			
		RTD or resistance transmitter, two-wire	RTD or resistance transmitter, three-wire	RTD or resistance transmitter, four-wire	Thermocouple (TC), voltage transmitter
Sensor input 2	RTD or resistance transmitter, two-wire	☑	☑	-	☑
	RTD or resistance transmitter, three- wire	☑	☑	-	☑
	RTD or resistance transmitter, four-wire	-	-	-	-
	Thermocouple (TC), voltage transmitter	☑	☑	☑	☑

 The dual sensor option must be included in the order code for the HART® protocol. Two sensor inputs are already provided as standard if the FF and PA protocol are selected.

## Output

### Output signal

HART® protocol	
Version	5
Device address in multi-drop mode	Software configuration, addresses 0 to 63
Write protection	Write protection activated by hardware or software setting
Device description files (DD)	Information and files are available free of charge at: <a href="http://www.endress.com">www.endress.com</a> <a href="http://www.hartcomm.org">www.hartcomm.org</a>
Load (communication resistor)	min. 250 Ω

FOUNDATION Fieldbus™	
Signal encoding	FOUNDATION Fieldbus™ H1, IEC 61158-2, Manchester Bus Powered (MBP)
Data transmission rate	31.25 kBit/s, voltage mode
Galvanic isolation	U = 2 kV AC (input/output)

PROFIBUS® PA	
Signal encoding	PROFIBUS® PA in accordance with EN 50170 Volume 2, IEC 61158-2, Manchester Bus Powered (MBP)
Data transmission rate	31.25 kBit/s, voltage mode
Galvanic isolation	U = 2 kV AC (input/output)

**Failure information**

HART® protocol	
<b>Failure information as per NAMUR NE43:</b> Failure information is created if the measuring information is missing or not valid. A complete list of all the errors occurring in the measuring system is created.	
Underranging	Linear decrease from 4.0 to 3.8 mA
Overranging	Linear increase from 20.0 to 20.5 mA
Failure e.g. sensor breakage; sensor short-circuit	≤ 3.6 mA ("low") or ≥ 21 mA ("high"), can be selected <sup>1)</sup>

- 1) The "high" alarm can be set between 21.6 mA and 23 mA allowing the flexibility needed to meet the requirements of most control systems.

FOUNDATION Fieldbus™
Status message in accordance with FOUNDATION Fieldbus™ specification

PROFIBUS® PA
Status messages and alarms in accordance with PROFIBUS® PA Profile 3.01/3.02 specification

**Load (HART®)**

$$R_{b \text{ max.}} = U_{b \text{ max.}} - 11 \text{ V} / 0.023 \text{ A (current output)}$$

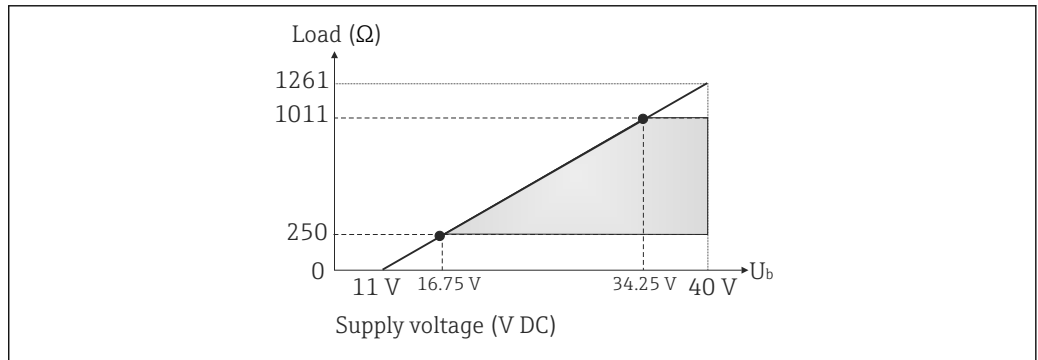

**Linearization/transmission behavior**

Temperature-linear, resistance-linear, voltage-linear

**Filter**

1st order digital filter: 0 to 60 s

**Protocol-specific data**

HART® protocol	
Version	5
Device address in multi-drop mode	Software setting
Write protection	Write protection activated by hardware or software setting
Device description files (DD)	Information and files are available free of charge online at: <a href="http://www.endress.com">www.endress.com</a> or <a href="http://www.hartcomm.org">www.hartcomm.org</a>
Load (communication resistor)	min. 250 Ω

FOUNDATION Fieldbus™		
Supported functions	Instantiation of function blocks. The following methods are supported: <ul style="list-style-type: none"> <li>▪ Quick Setup</li> <li>▪ User sensor trim</li> <li>▪ Factory trim settings</li> <li>▪ Callendar Van Dusen</li> <li>▪ Nickel/copper polynomial linearization</li> <li>▪ Sensor drift detection</li> </ul> For detailed descriptions, see the specific Operating Instructions.	
Basic data		
Manufacturer ID	452B48 (Endress+Hauser)	
Device type	10CC (Hex)	
Device or bus address	247 (default)	
Device revision	03 (hex)	
ITK Version	6.1.2	
ITK Certification Driver No.	IT099000	
Link Master capability (LAS)	Yes	
Choice of Link Master / Basic Device	Yes; factory setting: <b>Basic Device</b>	
Virtual Communication Relationship (VCRs)		
Number of VCRs	44	
Number of link objects in VFD	50	
Permanent entries	44	
Client VCRs	0	
Server VCRs	5	
Source VCRs	8	
Sink VCRs	0	
Subscriber VCRs	12	
Publisher VCRs	19	
Link settings		
Slot time	4	
Min. Inter PDU delay	12	
Max. response delay	40	
Blocks		
Block description	Execution time (macro cycle ≤ 500 ms)	Block category
Resource Block	Permanent	Extended
Transducer Block Sensor 1	Pre-instantiated	Manufacturer-specific
Transducer Block Sensor 2	Pre-instantiated	Manufacturer-specific
Transducer Block Display	Pre-instantiated	Manufacturer-specific
Transducer Block Adv. Diag.	Pre-instantiated	Manufacturer-specific
Function Block AI1	35 ms (pre-instantiated)	Extended
Function Block AI2	35 ms (pre-instantiated)	Extended
Function Block AI3	35 ms (pre-instantiated)	Extended
Function Block AI4	35 ms (not instantiated)	Extended
Function Block AI5	35 ms (not instantiated)	Extended
Function Block AI6	35 ms (not instantiated)	Extended
Function Block PID	30 ms	Standard
Function Block ISEL	30 ms	Standard



Brief block description	
Resource Block	The Resource Block contains all the data that clearly identify and characterize the device. It is an electronic version of a nameplate on the device. In addition to parameters that are needed to operate the device on the fieldbus, the Resource Block makes information such as the order code, device ID, hardware revision, software revision, device release etc. available.
Transducer Block "Sensor 1" and "Sensor 2"	The Transducer Blocks of the field transmitter contain all the measurement-specific and device-specific parameters which are relevant for the measurement of the input variables.
Display Transducer	The parameters of the "Display" Transducer Block enable the configuration of the display.
Advanced Diagnostic	All the parameters for self-monitoring and diagnostics are grouped in this Transducer Block.
Analog Input (AI)	In the AI Function Block, the process variables from the Transducer Blocks are prepared for subsequent automation functions in the control system (e.g. scaling, limit value processing).
PID	This function block contains input channel processing, proportional integral-differential control (PID) and analog output channel processing. The following can be realized: Basic controls, feedforward control, cascade control and cascade control with limiting.
Input Selector (ISEL)	The Input Selector Block enables the selection of up to four inputs and generates an output based on the configured action.

PROFIBUS® PA	
Profile version	3.02
Manufacturer-specific ID no.:	1549 (hex)
Device or bus address	126 (default) The device address or bus address is configured using either the configuration software, e.g. FieldCare, or the DIP switches on the electronics module. →  17
GSD files	Where to obtain GSD files and device drivers: <ul style="list-style-type: none"> <li>■ GSD file: <a href="http://www.de.endress.com">www.de.endress.com</a> → Downloads → Product code → Media type: Software</li> <li>■ Profile of GSD file: <a href="http://www.profibus.com">www.profibus.com</a></li> <li>■ FieldCare/DTM: <a href="https://portal.endress.com/webdownload/FieldCareDownloadGui">https://portal.endress.com/webdownload/FieldCareDownloadGui</a></li> <li>■ SIMATIC PDM: <a href="http://www.de.endress.com">www.de.endress.com</a> → Downloads → Product code → Media type: Software</li> </ul>
Write protection	Write protection activated by hardware setting (DIP switch)
Cyclical data exchange	
Output data	Value display
Input data	Process temperature, internal reference temperature

Brief block description	
Physical Block	The Physical Block contains all the data that clearly identify and distinguish the device. It is an electronic version of a nameplate on the device. In addition to parameters required to operate the device at the fieldbus, the Physical Block provides information such as order code, device ID, hardware revision, software revision etc. The Physical Block can also be used to configure the display.
Transducer Block "Sensor 1" and "Sensor 2"	The Transducer Blocks of the field transmitter contain all the measurement-specific and device-specific parameters which are relevant for the measurement of the input variables.
Analog Input (AI)	In the AI Function Block, the process variables from the Transducer Blocks are prepared for subsequent automation functions in the control system (e.g. scaling, limit value processing).

Switch-on delay

HART® protocol
4 s, during switch-on procedure $I_a \leq 4.0$ mA
FOUNDATION Fieldbus™
8 s
PROFIBUS® PA
8 s

Power supply

Terminal assignment

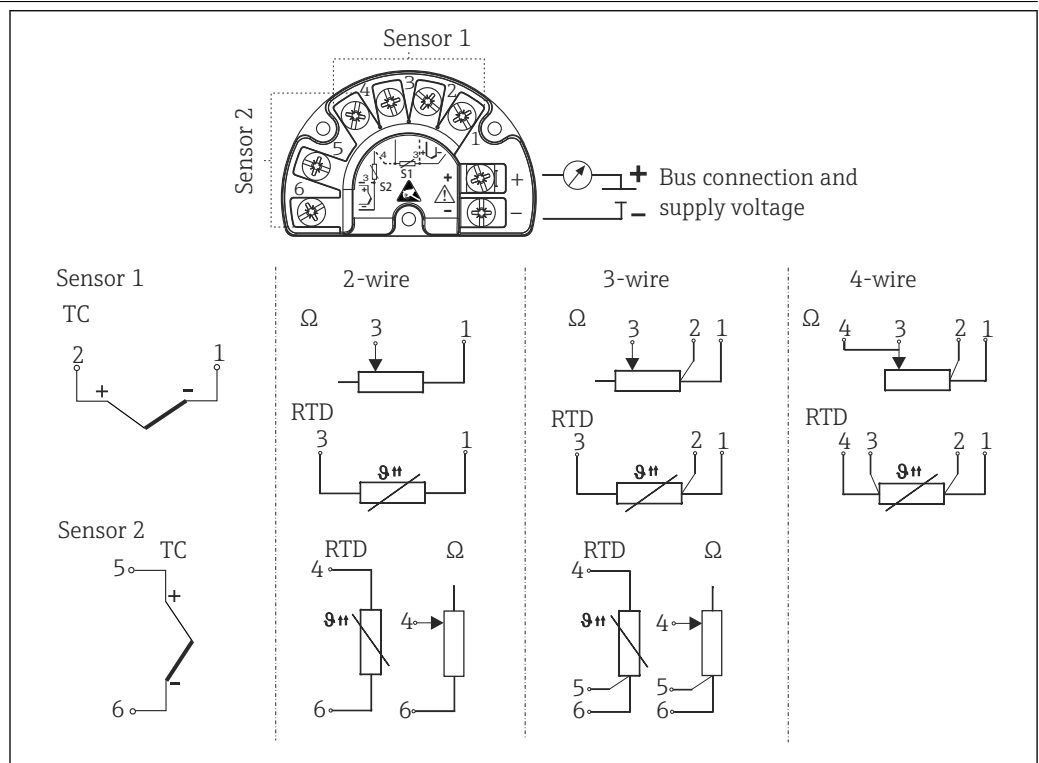

A0024515-EN

2 Wiring the transmitter

**Supply voltage****HART® protocol**

$U_b = 11$  to 40 V (8 to 40 V without display), reverse polarity protection



The transmitter must be powered by an 11 to 40 V<sub>DC</sub> power supply in accordance with NEC Class 02 (low voltage/low current) with restricted power limited to 8 A/150 VA in the event of a short-circuit (in accordance with IEC 61010-1, CSA 1010.1-92).

**FOUNDATION Fieldbus™**

$U_b = 9$  to 32 V, polarity-independent (reverse polarity protection for T17 housing), maximum voltage  $U_b = 35$  V. According to IEC 60079-27, FISCO/FNICO

**PROFIBUS® PA**

$U_b = 9$  to 32 V, polarity-independent (reverse polarity protection for T17 housing), maximum voltage  $U_b = 35$  V. According to IEC 60079-27, FISCO/FNICO

**Current consumption****HART® protocol**

Current consumption	3.6 to 23 mA
Minimum current consumption	≤ 3.5 mA
Current limit	≤ 23 mA

**FOUNDATION Fieldbus™**

Current consumption (device basic current)	≤ 11 mA
Switch-on current (device inrush current)	≤ 11 mA
Error current FDE (Fault Disconnection Electronic)	0 mA

**PROFIBUS® PA**

Current consumption (device basic current)	≤ 11 mA
Error current FDE (Fault Disconnection Electronic)	0 mA

**Terminals**

2.5 mm<sup>2</sup> (12 AWG) plus ferrule

**Cable entries**

Version	Type
Thread	2x thread ½" NPT
	2x thread M20
	2x thread G½"
Cable gland	2x coupling M20

**Device connector**

Version	Type
Thread and fieldbus connector	2x thread ½" NPT 1x connector 7/8" FF
	2x thread M20x1.5 1x connector 7/8" FF

**Residual ripple (HART®)**

Perm. residual ripple  $U_{SS} \leq 3$  V at  $U_b \geq 13.5$  V,  $f_{max.} = 1$  kHz

## Performance characteristics

**Response time**

Measured value update < 1 s per channel, depending on the type of sensor and connection method

**Reference operating conditions**

- Calibration temperature: +25 °C ±3 K (77 °F ±5.4 °F)
- Supply voltage: 24 V DC
- 4-wire circuit for resistance adjustment

**Maximum measured error**

The data relating to the measured error are typical values and correspond to a standard deviation of  $\pm 3 \sigma$  (normal distribution), i.e. 99.8% of all measured values achieve the specified values or better values.

	Designation	Accuracy	
		Digital	D/A <sup>1)</sup>
<b>Resistance thermometer (RTD)</b>	Cu100, Pt100, Ni100, Ni120	0.1 °C (0.18 °F)	0.02 %
	Pt500	0.3 °C (0.54 °F)	0.02 %
	Cu50, Pt50, Pt1000, Ni1000	0.2 °C (0.36 °F)	0.02 %
	Cu10, Pt200	1 °C (1.8 °F)	0.02 %
<b>Thermocouples (TC)</b>	K, J, T, E, L, U N, C, D S, B, R	typ. 0.25 °C (0.45 °F) typ. 0.5 °C (0.9 °F) typ. 1.0 °C (1.8 °F)	0.02 % 0.02 % 0.02 %
	Measuring range	Accuracy	
		digital	D/A <sup>1)</sup>
<b>Resistance transmitter (Ω)</b>	10 to 400 Ω	±0.04 Ω	0.02 %
	10 to 2 000 Ω	±0.08 Ω	0.02 %
<b>Voltage transmitter (mV)</b>	-20 to 100 mV	±10 μV	0.02 %

1) % refers to the set span. Accuracy for 4 to 20 mA output = digital + D/A

Physical input measuring range of sensors	
10 to 400 Ω	Cu10, Cu50, Cu100, polynomial RTD, Pt50, Pt100, Ni100, Ni120
10 to 2 000 Ω	Pt200, Pt500, Pt1000, Ni1000
-20 to 100 mV	Thermocouples type: C, D, E, J, K, L, N, U
-5 to 30 mV	Thermocouples type: B, R, S, T

**Sensor adjustment****Sensor transmitter matching**

RTD sensors are one of the most linear temperature measuring elements. Nevertheless, the output must be linearized. To significantly improve temperature measurement accuracy, the device allows the use of two methods:

- Customized linearization  
The transmitter can be programmed with sensor-specific curve data with the PC configuration software. As soon as the sensor-specific data have been entered, the transmitter uses these to create a customized curve.
- Callendar-Van-Dusen coefficients  
The Callendar-Van-Dusen equation is described as:  
$$R_T = R_0 [1 + AT + BT^2 + C(T - 100)T^3]$$

where A, B and C are constant. They are commonly referred as Callendar-Van-Dusen coefficients. The precise values of A, B and C are derived from the calibration data for the RTD and are specific for each RTD sensor. The process involves programming the transmitter with the curve data for a certain RTD instead of using a standardized curve.

Sensor transmitter matching using one of the methods explained above significantly improves the temperature measurement accuracy of the entire system. This is a result of the transmitter using the sensor's actual resistance vs. temperature curve data instead of the ideal curve data.

**Resolution**

Resolution of A/D converter = 18 bit

**Non-repeatability**

According to EN 61298-2

Physical input measuring range of sensors		Non-repeatability
10 to 400 Ω	Cu10, Cu50, Cu100, polynomial RTD, Pt50, Pt100, Ni100, Ni120	15 mΩ
10 to 2 000 Ω	Pt200, Pt500, Pt1000, Ni1000	100 ppm x measured value
-20 to 100 mV	Thermocouples type: C, D, E, J, K, L, N, U	4 μV
-5 to 30 mV	Thermocouples type: B, R, S, T	3 μV

**Influence of supply voltage (HART®)**

≤ 0.005 %/V deviation from 24 V, based on the full scale value.

**Long-term drift**

≤ 0.1 °C/year (≤ 0.18 °F/year) under reference operating condition or ≤ 0.05 %/year. Data under reference operating conditions. % refers to the set span. The larger value is valid.

**Influence of ambient temperature**

Impact on accuracy when ambient temperature changes by 1 °C (1.8 °F):	
Input 10 to 400 Ω	15 ppm of measured value, min. 1.5 mΩ
Input 10 to 2 000 Ω	15 ppm of measured value, min. 15 mΩ
Input -20 to 100 mV	30 ppm of measured value, min. 0.3 μV
Input -5 to 30 mV	30 ppm of measured value, min. 0.15 μV

**Typical sensitivities of resistance thermometers**

Pt: 0.00385 * R <sub>nom</sub> /K	Cu: 0.0043 * R <sub>nom</sub> /K	Ni: 0.00617 * R <sub>nom</sub> /K
-----------------------------------	----------------------------------	-----------------------------------

Example Pt100: 0.00385 x 100 Ω/K = 0.385 Ω/K

**Typical sensitivities of thermocouples**

B: 10 μV/K at 1 000 °C (1 832 °F)	C: 20 μV/K at 1 000 °C (1 832 °F)	D: 20 μV/K at 1 000 °C (1 832 °F)	E: 75 μV/K at 500 °C (932 °F)	J: 55 μV/K at 500 °C (932 °F)	K: 40 μV/K at 500 °C (932 °F)
L: 55 μV/K at 500 °C (932 °F)	N: 35 μV/K at 500 °C (932 °F)	R: 12 μV/K at 1 000 °C (1 832 °F)	S: 12 μV/K at 1 000 °C (1 832 °F)	T: 50 μV/K at 1 000 °C (1 832 °F)	U: 60 μV/K at 500 °C (932 °F)

**Examples of calculating the measured error with ambient temperature drift****Example 1:**

Input temperature drift Δθ = 10 K (18 °F), Pt100, measuring range 0 to +100 °C (+32 to +212 °F)

Maximum process temperature: 100 °C (212 °F)

Resistance value measured: 138.5 Ω (IEC 60751) at maximum process temperature

Typical temperature drift in Ω: (0.001% of 138.5 Ω) \* 10 = 0.01385 Ω

Conversion to Kelvin: 0.01385 Ω / 0.385 Ω/K = 0.04 K (0.054 °F)

**Influence of the reference junction**

Pt100 DIN IEC 60751 Cl. B (internal cold junction with thermocouples TC)

## Installation

**Mounting location**

If stable sensors are used, the device can be fitted directly to the sensor. For remote mounting to a wall or stand pipe, two mounting brackets are available. The illuminated display can be mounted in four different positions.

## Installation instructions

## Direct sensor mounting

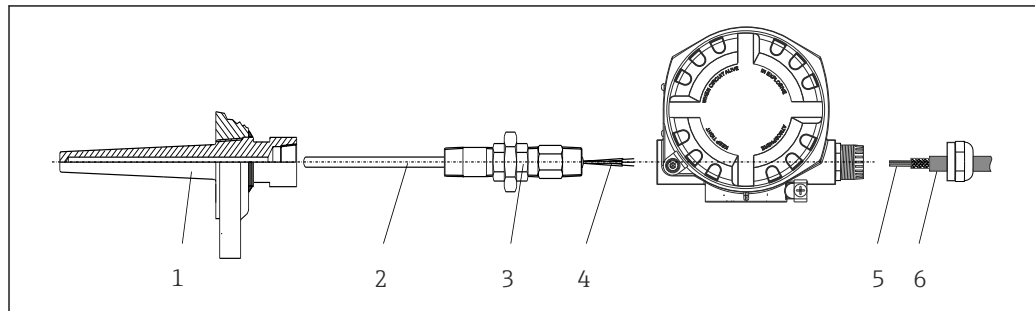

A0024817

 3 Direct field transmitter mounting on sensor

- 1 Thermowell
- 2 Insert
- 3 Neck tube nipple and adapter
- 4 Sensor cables
- 5 Fieldbus cables
- 6 Fieldbus shielded cable

## Remote mounting

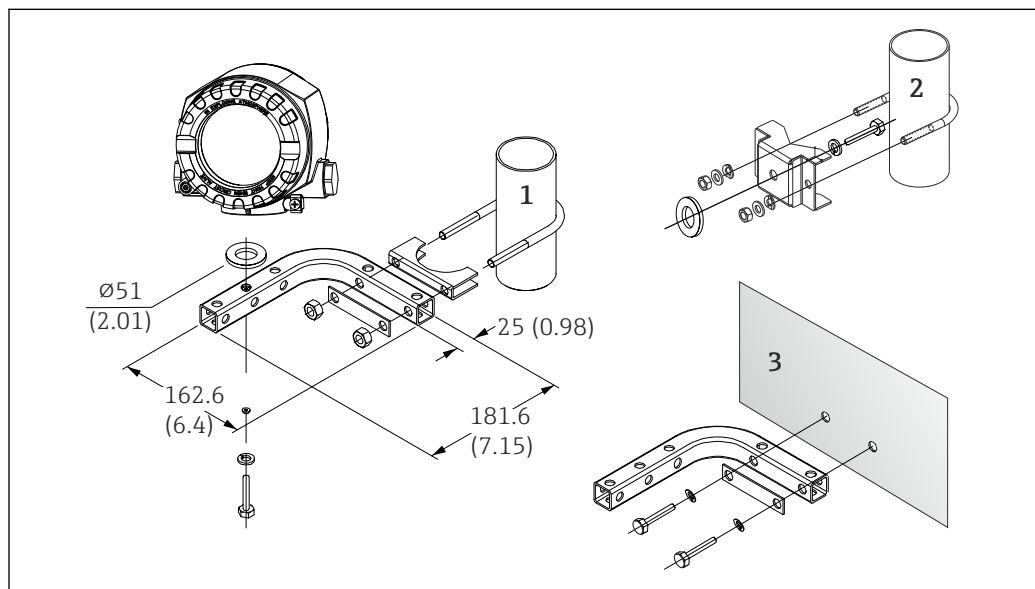

A0003586-EN

 4 Installing the field transmitter using the mounting bracket, see "Accessories" section. Dimensions in mm (in)

- 1 Mounting with combined wall/pipe mounting bracket
- 2 Mounting with pipe mounting bracket 2"/V4A
- 3 Mounting with wall mounting bracket

## Display mounting

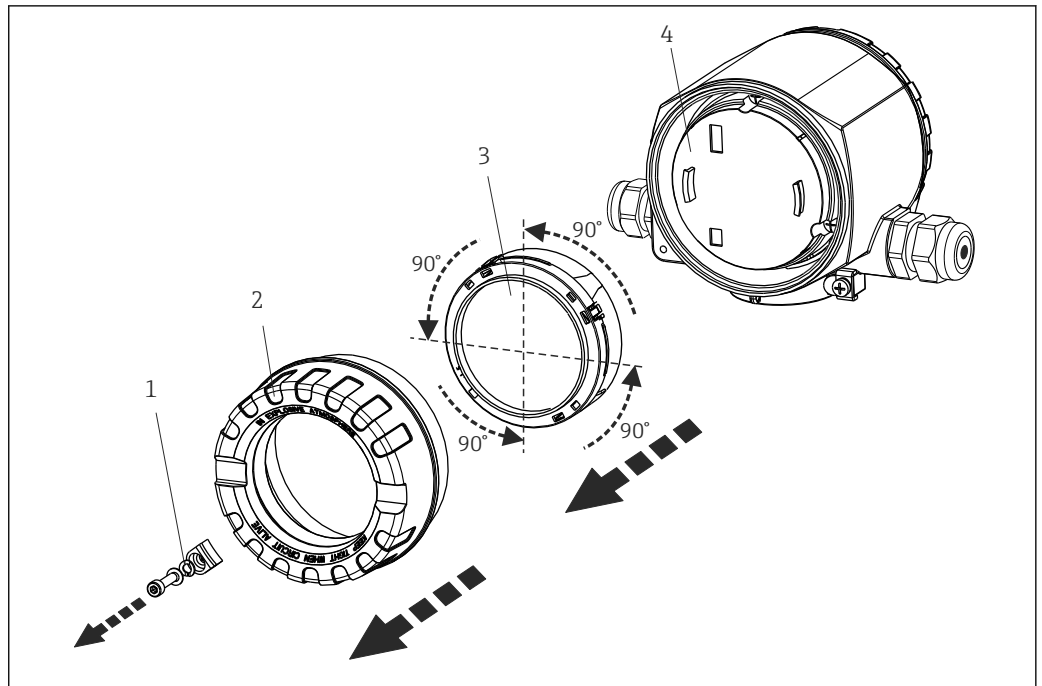

A0025417

5 4 display installation positions, attachable in 90° stages

- 1 Cover clamp
- 2 Housing cover with O-ring
- 3 Display with retainer and twist protection
- 4 Electronics module

## Environment

### Ambient temperature range

- Without display: -40 to +85 °C (-40 to +185 °F)
- With display: -40 to +80 °C (-40 to +176 °F)

For hazardous areas see Ex documentation → 22

**i** The display can react slowly at temperatures < -20 °C (-4 °F). The legibility of the display cannot be guaranteed at temperatures < -30 °C (-22 °F).

### Storage temperature

- Without display: -50 to +100 °C (-58 to +212 °F)
- With display: -50 to +80 °C (-58 to +176 °F)

### Humidity

Permitted

### Altitude

Up to 2 000 m (6 560 ft) above mean sea level in accordance with IEC 61010-1, CSA 1010.1-92

### Climate class

As per IEC 60654-1, Class C

### Degree of protection

- Die-cast aluminum or stainless steel housing: IP67, NEMA 4X
- Stainless steel housing for hygienic applications (T17 housing): IP66 / IP68 (1.83 m H<sub>2</sub>O for 24 h), NEMA 4X, NEMA 6P

### Shock and vibration resistance

2 to 150 Hz at 3g as per IEC 60068-2-6

**i** The use of L-shaped mounting brackets can cause resonance (see wall/pipe 2" mounting bracket in the 'Accessories' section). Caution: vibrations at the transmitter may not exceed specifications.

**Electromagnetic compatibility (EMC)****CE compliance**

The device meets all the requirements specified in IEC 61326, Amendment 1, 1998 and NAMUR NE21. This recommendation is a uniform and practical way of determining whether the devices used in laboratories and process control are immune to interference with the objective of increasing their functional safety.

ESD (electrostatic discharge)	EN/IEC 61000-4-2	6 kV cont., 8 kV air	
Electromagnetic fields	EN/IEC 61000-4-3	0.08 to 4 GHz	10 V/m
Burst (fast transients)	EN/IEC 61000-4-4	1 kV	
Surge (surge voltage)	EN/IEC 61000-4-5	1 kV assym.	
Conducted RF	EN/IEC 61000-4-6	0.01 to 80 MHz	10 V

**Measuring category**

Measuring category II as per IEC 61010-1. The measuring category is provided for measuring on power circuits that are directly connected electrically with the low-voltage network.

**Degree of contamination**

Pollution degree 2 as per IEC 61010-1.

**Mechanical construction****Design, dimensions**

Dimensions in mm (in)

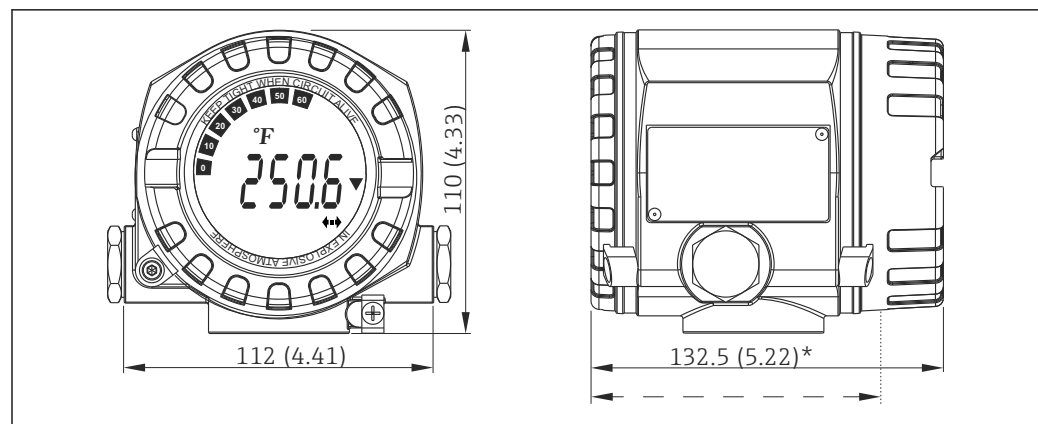

A0024608

 6 Die-cast aluminum housing for general applications, or optional stainless steel housing (316L)

 \* Dimensions without display = 112 mm (4.41")

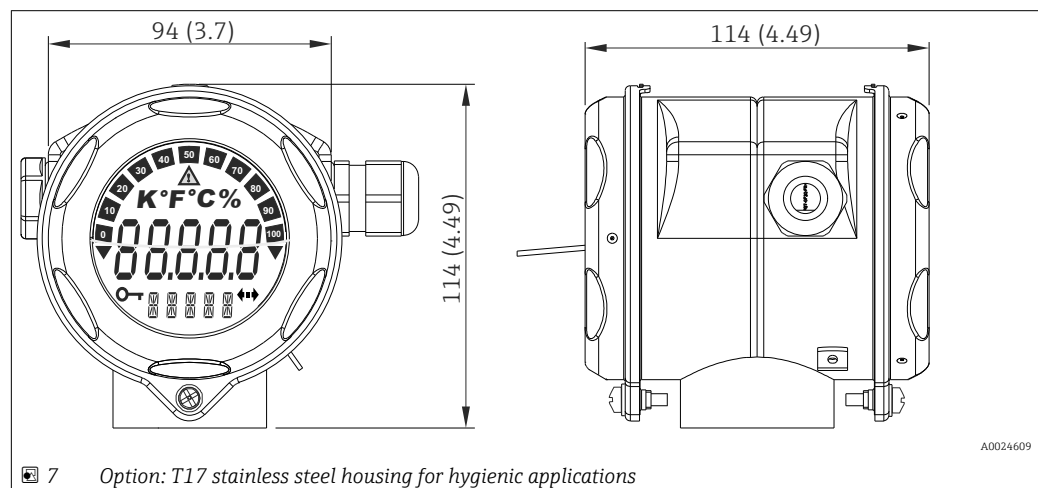

A0024609

 7 Option: T17 stainless steel housing for hygienic applications



- Separate electronics module and connection compartment
- Display attachable in 90° stages

**Weight**

- Aluminum housing approx. 1.4 kg (3 lb), with display
- Stainless steel housing approx. 4.2 kg (9.3 lb), with display
- T17 housing approx. 1.25 kg (2.76 lb), with display

**Materials**

Housing	Sensor terminals	Nameplate
Die-cast aluminum housing AlSi10Mg/ AlSi12 with powder coating on polyester base	Nickel-plated brass 0.3 µm gold flashed / cpl., corrosion-free	Aluminum AlMg1, anodized in black
316L		1.4404 (AISI 316L)
Stainless steel 1.4435 (AISI 316L) for hygienic applications (T17 housing)		-

**Cable entries**

Version	Type
Thread	2x thread ½" NPT
	2x thread M20
	2x thread G½"
Cable gland	2x coupling M20

## Operability

**Operating concept**

There are different options available for configuring and commissioning the device:

- **Configuration programs**

The configuration of device-specific parameters is done primarily via the HART protocol as well as the fieldbus interface. There are specific configuration or operating programs from different manufacturers available to the user for this purpose. Bedienprogramme zur Verfügung.

- **Miniature switches (DIP switches) and jumpers for various hardware settings**

Jumpers J1, J2 and J3 (HART®) for hardware setup can be found in the electronics module. You can perform the following hardware settings for the fieldbus interface (PROFIBUS® PA and FOUNDATION Fieldbus™) using miniature switches (DIP switches) on the electronics module:

- Enabling/disabling of simulation mode (FOUNDATION Fieldbus™)
- Switching the hardware write protection on/off
- Configuration of device address (PROFIBUS® PA)

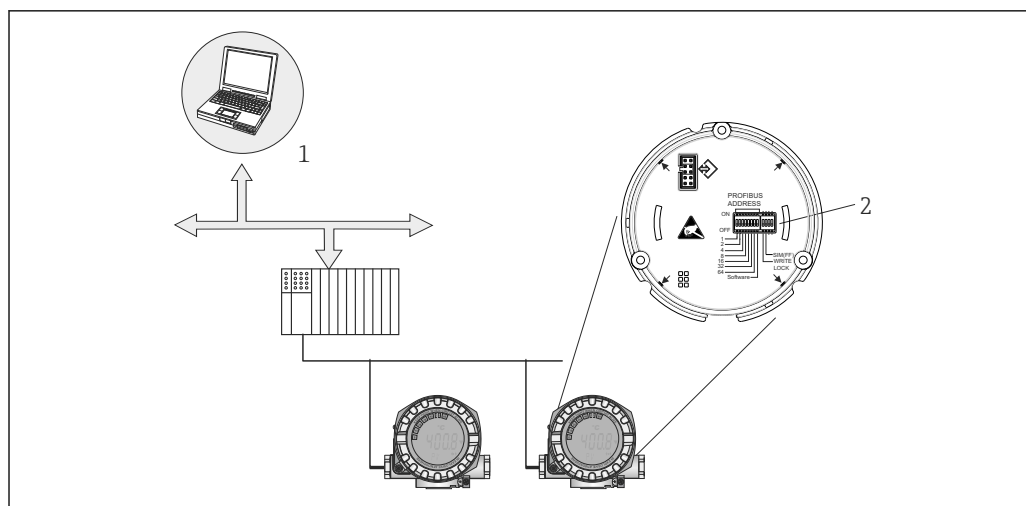

A0024548

### 8 Operating options of device

- 1 Configuration/operating programs for operating via fieldbus or HART® protocol
- 2 DIP switches for hardware settings (write protection, simulation mode)

## Local operation

### Display elements

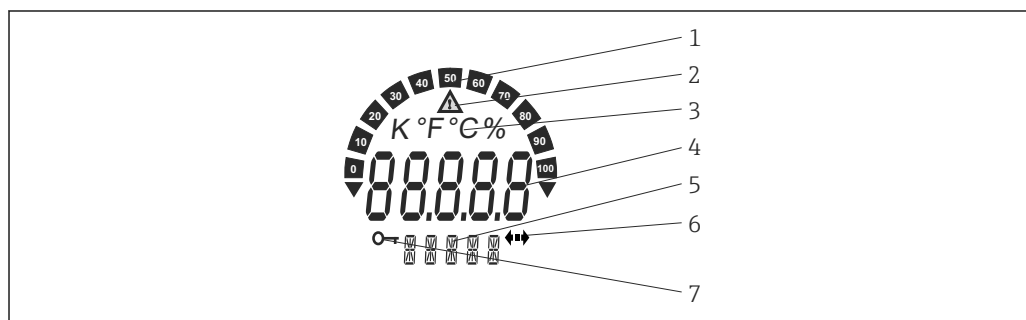

A0024547

### 9 LC display of the field transmitter (illuminated, can be plugged in in 90° steps)

- 1 Bar graph display
- 2 'Caution' symbol
- 3 Unit display K, °F, °C or %
- 4 Measured value display, digit height 20.5 mm
- 5 Status and information display
- 6 'Communication' symbol
- 7 'Configuration locked' symbol

**Operating elements**

To prevent manipulation, no operating elements are present directly on the display.

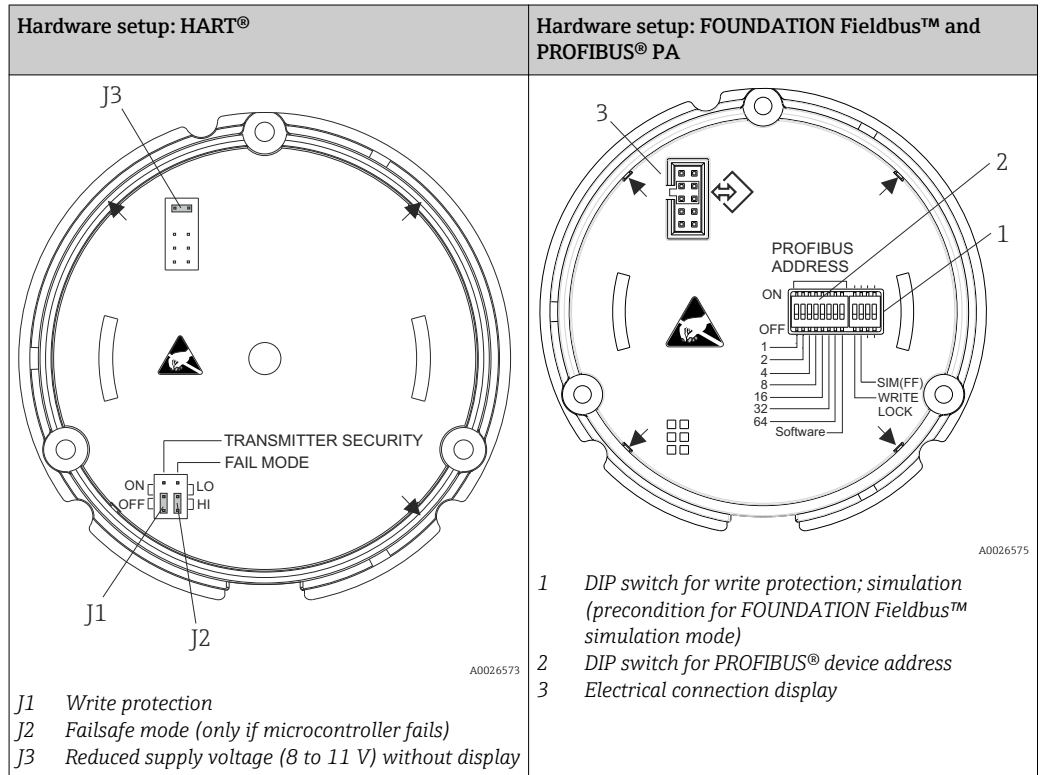

**Remote operation**

Remote operation via different fieldbus protocols:

- HART® protocol
- FOUNDATION Fieldbus™
- PROFIBUS® PA

**Certificates and approvals**

**CE mark**

The measuring system meets the legal requirements of the EC guidelines. The manufacturer confirms that the device conforms to all relevant guidelines by affixing the CE mark.

**Ex approval**

Information about currently available Ex versions (ATEX, FM, CSA, etc.) can be supplied by your E+H Sales Center on request. All explosion protection data are given in separate documentation which is available upon request.

**MTBF**

- HART®: **147 a**
- FOUNDATION Fieldbus™: **126 a**
- PROFIBUS® PA: **126 a**

according to Siemens Standard SN29500

**Equipment safety UL**

Equipment safety UL Equipment safety as per UL61010-1 (HART® device only)

**CSA GP**

CAN/CSA-C22.2 No. 61010-1, 2nd Edition

**GL**

Ship building approval - Germanischer Lloyd (HART® device only)

**Functional safety according to IEC 61508 / IEC 61511**

FMEDA including SFF determination and PFDAVG-calculation according to IEC 61508. See also Functional Safety Manual in Section 'Documentation' (for HART® device).

**FOUNDATION Fieldbus certification**

The temperature transmitter is certified and registered by the Fieldbus FOUNDATION. The measuring system meets all the requirements of the following specifications:

- Certified in accordance with FOUNDATION Fieldbus™ specification
- FOUNDATION Fieldbus™ H1
- Interoperability Test Kit (ITK), revision status 6.1.2, device certification number → ⓘ 7: The device can also be operated with certified devices of other manufacturers.
- Physical Layer Conformance Test of the Fieldbus FOUNDATION™ (FF-830 FS 1.0)

**PROFIBUS® PA certification**

The temperature transmitter is certified and registered by the PNO (PROFIBUS® Nutzerorganisation e. V.), PROFIBUS user organization. The device meets all the requirements of the following specifications:

- Certified in accordance with PROFIBUS® PA Profile 3.02.
- The device can also be operated with certified devices of other manufacturers (interoperability).

**Other standards and guidelines**

- **IEC 60529:** Degrees of protection provided by enclosures (IP code)
- **IEC 61010:** Safety requirements for electrical equipment for measurement, control and laboratory use.
- **IEC 61326:** Electromagnetic compatibility (EMC requirements)
- **NAMUR** - Standardization organization for measurement and control processes in the chemical and pharmaceutical industry. ([www.namur.de](http://www.namur.de))
- **NEMA** - Standardization organization for the electrical industry.

## Ordering information

Detailed ordering information is available from the following sources:

- In the Product Configurator on the Endress+Hauser website: [www.endress.com](http://www.endress.com) → Select your country → Products → Select measuring technology, software or components → Select the product (picklists: measurement method, product family etc.) → Device support (right-hand column): Configure the selected product → The Product Configurator for the selected product opens.
- From your Endress+Hauser Sales Center: [www.addresses.endress.com](http://www.addresses.endress.com)



### Product Configurator - the tool for individual product configuration

- Up-to-the-minute configuration data
- Depending on the device: Direct input of measuring point-specific information such as measuring range or operating language
- Automatic verification of exclusion criteria
- Automatic creation of the order code and its breakdown in PDF or Excel output format
- Ability to order directly in the Endress+Hauser Online Shop

## Accessories

Various accessories, which can be ordered with the device or subsequently from Endress+Hauser, are available for the device. Detailed information on the order code in question is available from your local Endress+Hauser sales center or on the product page of the Endress+Hauser website: [www.endress.com](http://www.endress.com).





Always quote the serial number of the device when ordering accessories!

**Device-specific accessories**

Accessories	Description
Dummy plugs	<ul style="list-style-type: none"> <li>▪ M20x1.5 EEx-d/XP</li> <li>▪ G ½" EEx-d/XP</li> <li>▪ NPT ½" ALU</li> <li>▪ NPT ½" V4A</li> </ul>
Cable glands	<ul style="list-style-type: none"> <li>▪ M20x1.5</li> <li>▪ NPT ½" D4-8.5, IP68</li> <li>▪ NPT ½" cable gland 2 x D0.5 cable for 2 sensors</li> <li>▪ M20x1.5 cable gland 2 x D0.5 cable for 2 sensors</li> </ul>

Accessories	Description	
Adapter for cable gland	M20x1.5 inside/M24x1.5 outside	
Wall and pipe mounting bracket	Stainless steel wall/2" pipe Stainless steel 2" pipe V4A	
Fieldbus device connector (FF)	<b>Threaded connection:</b>	<b>Cable connection thread:</b>
	M20	7/8"
	NPT 1/2"	7/8"
Surge arrester HAW569	M20x1.5 threaded connection; suitable for HART®, FF and PA fieldbus connection Order code: HAW569-Axxx for non-hazardous area Order code: HAW569-Cxxx or -Dxxx for ATEX/IECEX approval  For additional technical data, see Technical Information: TI01013K/09	

### Communication-specific accessories



Accessories	Description
Field Xpert SFX350	Field Xpert SFX350 is a mobile computer for commissioning and maintenance. It enables efficient device configuration and diagnostics for HART and FOUNDATION Fieldbus devices in the <b>non-Ex area</b> .  For details, see Operating Instructions BA01202S
Field Xpert SFX370	Field Xpert SFX370 is a mobile computer for commissioning and maintenance. It enables efficient device configuration and diagnostics for HART and FOUNDATION Fieldbus devices in the <b>non-Ex area and the Ex area</b> .  For details, see Operating Instructions BA01202S

### Service-specific accessories

Accessories	Description
Applicator	Software for selecting and sizing Endress+Hauser measuring devices: <ul style="list-style-type: none"> <li>Calculation of all the necessary data for identifying the optimum measuring device: e.g. pressure loss, accuracy or process connections.</li> <li>Graphic illustration of the calculation results</li> </ul> Administration, documentation and access to all project-related data and parameters over the entire life cycle of a project. Applicator is available: <ul style="list-style-type: none"> <li>Via the Internet: <a href="https://wapps.endress.com/applicator">https://wapps.endress.com/applicator</a></li> <li>On CD-ROM for local PC installation.</li> </ul>
Konfigurator <sup>+temperature</sup>	Software for selecting and configuring the product depending on the measuring task, supported by graphics. Includes a comprehensive knowledge database and calculation tools: <ul style="list-style-type: none"> <li>For temperature competence</li> <li>Quick and easy design and sizing of temperature measuring points</li> <li>Ideal measuring point design and sizing to suit the processes and needs of a wide range of industries</li> </ul> The Konfigurator is available: On request from your Endress+Hauser sales office on a CD-ROM for local PC installation.
W@M	Life cycle management for your plant W@M supports you with a wide range of software applications over the entire process: from planning and procurement, to the installation, commissioning and operation of the measuring devices. All the relevant device information, such as the device status, spare parts and device-specific documentation, is available for every device over the entire life cycle. The application already contains the data of your Endress+Hauser device. Endress+Hauser also takes care of maintaining and updating the data records. W@M is available: <ul style="list-style-type: none"> <li>Via the Internet: <a href="http://www.endress.com/lifecyclemanagement">www.endress.com/lifecyclemanagement</a></li> <li>On CD-ROM for local PC installation.</li> </ul>

FieldCare	<p>FDT-based plant asset management tool from Endress+Hauser. It can configure all smart field units in your system and helps you manage them. By using the status information, it is also a simple but effective way of checking their status and condition.</p> <p> For details, see Operating Instructions BA00027S and BA00059S</p>
-----------	--

## System components

Accessories	Description
Graphic Data Manager Memograph M	<p>The Memograph M graphic data manager provides information on all the relevant process variables. Measured values are recorded correctly, limit values are monitored and measuring points analyzed. The data are stored in the 256 MB internal memory and also on a SD card or USB stick.</p> <p> For details, see Technical Information TI133R/09</p>
Paperless recorder Ecograph T	<p>Multi-channel data recording system with LC color graphic display (120 mm / 4.7" screen size), galvanically isolated universal inputs (U, I, TC, RTD), digital input, transmitter power supply, limit relay, communication interfaces (USB, Ethernet, RS232/485), Internal flash memory and compact flash card.</p> <p> For details, see Technical Information TI01079R/09</p>
RID14, RID16	<p>8-channel field display unit with FOUNDATION Fieldbus™ or PROFIBUS® PA protocol - for easy integration into existing fieldbus systems. RID14 as version in flameproof housing.</p> <p> For details, see Technical Information TI00145R/09 (RID14) and TI00146R/09 (RID16)</p>

## Documentation

- FOUNDATION Fieldbus™ Function Blocks manual (BA062S/04)
  - Supplementary ATEX documentation:
    - ATEX/IECEX II 2G Ex d IIC T6...T4 Gb: XA00031R/09/a3
    - ATEX/IECEX II 2D Ex tb IIIC T110 °C Db: XA00032R/09/a3
    - ATEX/IECEX II 1G Ex ia IIC T6/T5/T4: XA00033R/09/a3
    - ATEX II 3G Ex nA IIC T6...T4 Gc: XA00035R/09/a3
    - ATEX/IEC Installation type Ex ia + Ex d: XA01025R/09/a3
    - ATEX II 3G Ex ic IIC T6...T4 Gc: XA00062R/09/a3
  - iTEMP TMT162 HART® Operating Instructions (BA00132R/09/) + Functional Safety Manual (SD005R/09/en)  
iTEMP TMT162 HART® - Brief Operating Instructions (KA00250R/09)
  - iTEMP TMT162 FOUNDATION Fieldbus™ - Operating Instructions (BA00224R/09/en)  
iTEMP TMT162 FOUNDATION Fieldbus™ - Brief Operating Instructions (KA00189R/09)
  - iTEMP TMT162 PROFIBUS® PA - Operating Instructions (BA00275R/09/en)  
iTEMP TMT162 PROFIBUS® PA - Brief Operating Instructions (KA00276R/09)
- Technical Information Omnigrad S TMT162R and TMT162C (TI00266T/02/en and TI00267T/02/en)

---

[www.addresses.endress.com](http://www.addresses.endress.com)

---