

Source 3000

Self-Contained Pressure Source Console

TRANSCAT

▶ Visit us at Transcat.com!

35 Vantage Point Drive // Rochester, NY 14624 // Call 1.800.800.5001

Operation and Maintenance Manual



CONDEC 
Genuine Quality, Proven Performance.

Contents

About This Manual	1
1.0 Introduction.....	1
2.0 Operation.....	3
2.1 Pressure Cylinder Filling	3
2.2 Initial Setup	4
2.3 Pressure Measurement Sequence	4
3.0 Maintenance	5
3.1 Troubleshooting.	5
3.2 Maintenance Procedures.	5
3.2.1 Front Panel Removal.	5
3.2.2 Nitrogen Cylinder Assembly Removal (PN 65622)	5
3.2.3 Installing New Nitrogen Cylinder Assembly (PN 65622)	6
3.2.4 ORION 2C Manifold Removal (PN 58822)	6
3.2.5 ORION 2C Manifold, Valve Seat Removal	6
3.2.6 ORION 2C Manifold, Vernier Control Disassembly.	7
3.2.7 ORION 2C Manifold, Vernier Control Reassembly	8
3.2.8 ORION 2C Manifold, Valve Seat Installation.	8
3.2.9 ORION 2C Manifold, Panel Installation	9
3.2.10 ORION 2C Manifold, Valve Adjustment Procedure	9
3.2.11 Pressure Limit Control (PN 65455), Regulator Removal.	10
3.2.12 Pressure Limit Control (PN 65455), Regulator Installation	10
3.2.13 Panel Gage Removal	11
3.2.14 Panel Gage Installation	11
3.2.15 Port 1 & Port 2 Quick-Connect Fitting (PN 55426), Removal and Installation.	11
3.2.16 Port 1, Port 2 and Fill Port Filter (PN 54188)	12
3.2.17 Inlet Check Valve (PN 60263) (Nitrogen Fill Port)	12
3.3 Orion 2C Valve Assembly Parts List	13
4.0 Specifications	16
Source 3000 Warranty and Return Policy	17
Source 3000 Return Material Authorization Form.....	18

About This Manual

The Source 3000 is a portable, self-contained pneumatic pressure console with precision vernier. A rugged, compact instrument manufactured by Condec, designed to provide ease of operation when used in conjunction with multiple manufacturers electronic calibrators, for the calibration of a wide variety of pressure sensing and measuring devices.

Equipped to perform rapid on-site calibrations, these instruments have proven to substantially reduce the cost, system down-time and man-hours of labor normally associated with these routine service functions.

This instrument is an all mechanical device that combines a 15 cubic foot, 3000 PSI cylinder with our precision Orion 2C vernier. The unit has multiple ports. Front panel gages tell the operator system pressure, as well as, remaining pressure in the internal cylinder. A pressure regulator will act as a pressure limiter so that the operator can not over pressure a unit under test. Adapter fittings are supplied for the customer to put on their fill hose and test hose.

This manual has been written to give the user a simple and clear explanation of how to operate, and troubleshoot these instruments.



Warning

Before attempting to use the Source 3000, Self Contained Pressure Source, the following instructions must be carefully read and understood by personnel utilizing the equipment. This is a high-pressure system. While a substantial effort has been expended to make this equipment safe, simple and fool-proof to operate, it is strongly recommended that only personnel formally trained in the use of pneumatic pressure equipment be permitted to operate it. Potentially dangerous conditions could be produced through negligent handling or operation of the console due to the high pressure cylinder contained within the unit.

These units are strictly for use with pneumatic pressures. Erroneous readings and potential damage could result from the introduction of hydraulic fluids into the internal tubing lines.



Authorized distributors and their employees can view or download this manual from the Condec distributor site at www.4condec.com.

1.0 Introduction

The Source 3000 represents the latest in technology, offering a combination of features, performance, versatility and reliability not previously available in a single, self-contained pressure source instrument. Some of the more outstanding features are listed below:

- Using a manually adjustable regulator, the maximum system input pressure is adjusted to any desired value higher (typically 20 to 50%) than the full scale range of the device being tested. By virtue of this technique, the unit under test is fully protected from being inadvertently over-pressurized.
- Portable: These compact, self-contained systems are easily carried and operated by only one person. Total weight is approximately 25 pounds.
- Pressure Source: An internal supply cylinder with a volume of 15.0 std. cu. ft. of N₂ provides up to 3000 PSIG of pressure for calibration and test. A check valve quick disconnect fitting provides re-charging capability.
- Simple Operation: All controls, gages and pressure ports are accessible from the front panel. Accompanying operator's manual provides clear, concise instructions for system operation.
- Safe, Clean Operation: All pressure components are made of brass, aluminum or stainless steel and proof-tested to at least 150% of maximum operating pressure. In addition, the system contains a high-pressure burst disk to protect both the operator and system components from harm in the event of inadvertent over-pressurization.

The heart of the Source 3000 are the two micro-metering valves and the vernier provided for control of the internal nitrogen source. Overpressure protection is provided by a fully adjustable pressure regulator which is manually set for each new device being tested. The Source 3000 is designed for compatibility with all major manufacturer's electronic calibration equipment.

The following schematic provides an overview of the Source 3000's function.

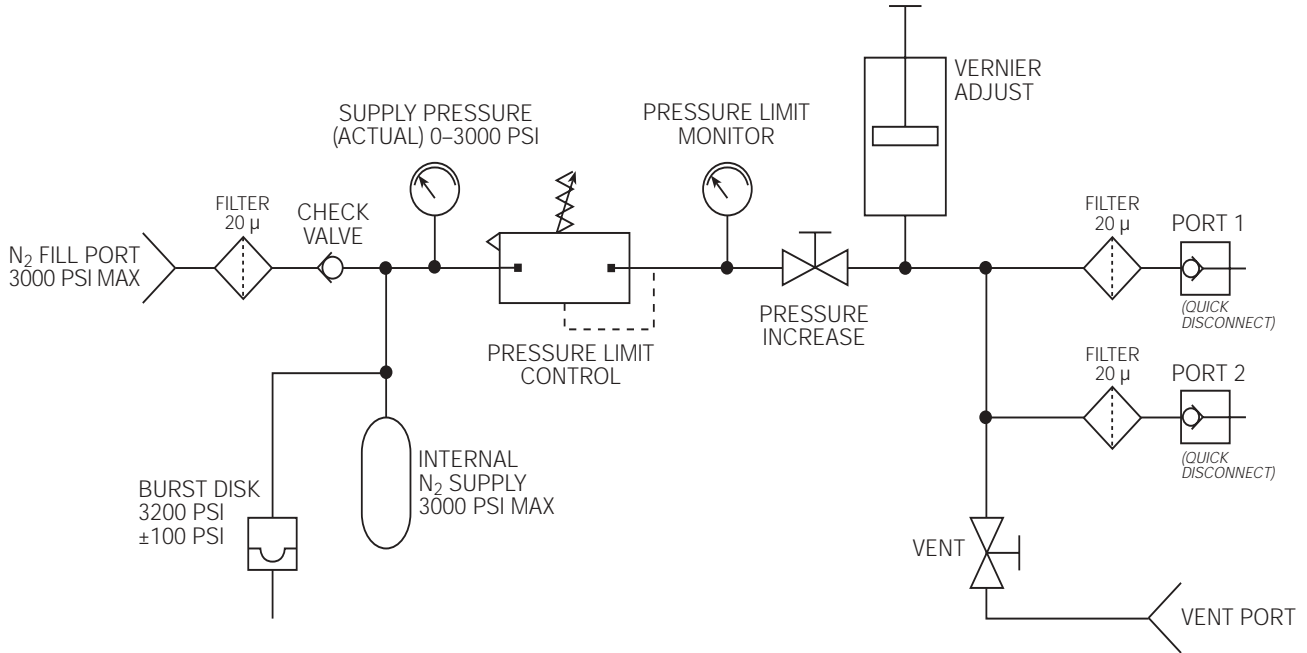

Figure 1-1. Source 3000 Flow Diagram

2.0 Operation

2.1 Pressure Cylinder Filling

To initially fill or refill the internal pressure cylinder (3000 PSI max.) of the Source 3000, see Figure 2-1 below and proceed as described below.

NOTE: The pressure cylinder used as the filling source must be regulated to provide a maximum output of 3049 PSIG.

1. Rotate the *PRESSURE LIMIT CONTROL* (1) counter-clockwise until it stops. Close the *COARSE ADJUSTMENT* valve (2) by rotating clockwise until it stops.
2. Connect the fill hose (3), supplied by customer, to a clean regulated nitrogen source (5).
3. Connect the other end of the fill hose (3) supplied by customer, to the male fill port fitting (4). Use supplied AN to 1/8 male NPT adapter fitting, (PNs 59839 and 59708) and cheat seal pad (PN 54854) between fill hose & fill port.
4. Slowly open the valve on the nitrogen source and allow the gas to flow into the pressure cylinder. **NOTE:** *Inlet check valve could be damaged if pressure is released too fast.* The *SUPPLY PRESSURE* gage (6) indicates the amount of pressure within the internal cylinder. Use the following procedure for filling the cylinder:
 - a) Fill cylinder to 1000 PSI at a rate of charge equal to a minimum of two minutes, then wait five minutes for system to stabilize.
 - b) Fill cylinder from 1000 PSI to 2000 PSI at a rate of charge equal to a minimum of two minutes, then wait five minutes for system to stabilize.
 - c) Fill cylinder from 2000 PSI to 3000 PSI at a rate of charge equal to a minimum of two minutes. Wait five minutes for system to stabilize before using.

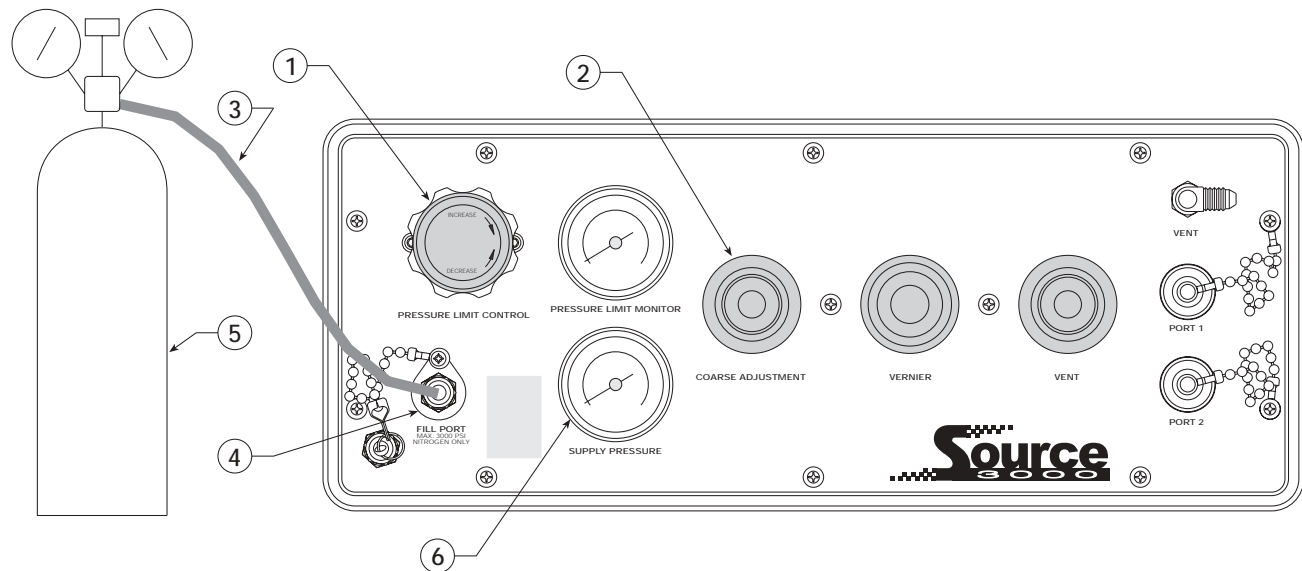

Figure 2-1. Pressure Cylinder Fill Procedure

2.2 Initial Setup

To prepare for actual calibration usage, see Figure 2-2 below and proceed as follows:

1. Check that the *COARSE ADJUSTMENT* valve (1) is closed (rotate clockwise until it stops) and that the vent valve (2) is open (two turns counter-clockwise from its stop).
2. Using the *PRESSURE LIMIT CONTROL* regulator (5), adjust the maximum system input pressure, as read by the pressure limit monitor (4), to any desired value higher (typically 20–50% higher) than the full-scale range of the device under test. Using this technique, the device under test is fully protected from being accidentally over-pressurized.
3. Connect the male quick disconnect end of the port hose supplied by customer to one of the port (6) fittings. Use supplied 1/4 female NPT quick disconnect fitting, (PN 55394) between port hose and Port 1 or Port 2.
4. Connect the other end of the port hose to the input port of the electronic standard, using adapters if required. Tighten all connections.
5. Connect the end of the test hose supplied by customer to the electronic standard output port and the other end to the unit under test. Tighten all connections properly. **NOTE:** If using a tee type port/test hose connection, the electronic standard is connected between the port and unit under test.

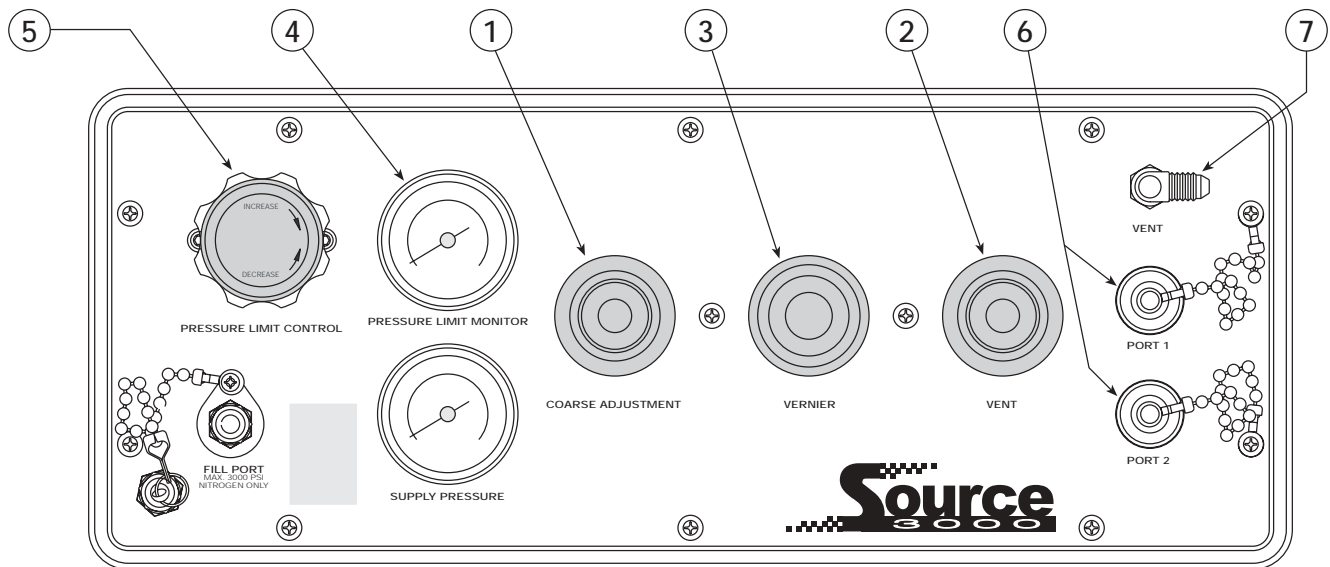

Figure 2-2. Initial Setup Procedure

2.3 Pressure Measurement Sequence

1. To apply pressure, close the *VENT* valve (2) approximately two turns until it stops, then open the *COARSE ADJUSTMENT* valve (1) approximately 1/2 turn counter-clockwise until the display begins to move. The pressure may change rapidly until reaching approximately 90% of the desired final value.
2. Use either the *COARSE ADJUSTMENT* or *VENT* valve to obtain a specific pressure reading. Both provide precise control. As the pressure approaches the desired value, the valve being used for control should be rotated slowly clockwise to its closed position. With a little experience, pressure values very close to the desired final value may be quickly achieved.
3. To obtain exact pressure readings, slowly rotate the *VERNIER* control (3) knob in the direction required (clockwise to increase pressure) as indicated by the electronic standard display.

3.0 Maintenance

3.1 Troubleshooting

Symptom	Problem	Remedy
Customers electronic standard display slowly decreases over time	Leak in system	Check all compression and pipe fittings with soap solution
Electronic standard display does not respond when Vernier knob is turned	No Vernier control	Readjust isolation valves on Orion; replace O-ring on Vernier piston
Electronic standard display increases or decreases when <i>PRESSURE</i> or <i>VENT</i> valves are closed	No Pressure or Vent control	Replace valve seats or O-rings in valves; check valve needles
Gas escapes when external supply pressure is bled	N ₂ cylinder will not remain charged	Remove inlet check valve; clean or replace

Table 3-1. Source 3000 Troubleshooting

3.2 Maintenance Procedures

This section outlines the mechanical repair procedures for the Source 3000 pressure source. The repair procedures cover the major components and subassemblies which are critical to the proper functioning of the calibrators and that will likely need periodic maintenance over the life of the unit. Only those persons who are formally trained as skilled technicians should attempt to repair these units. All relevant safety precautions should be observed due to the presence of high-pressure cylinders.

3.2.1 Front Panel Removal

Tools required: Phillips screwdriver

1. Loosen and remove the ten screws (PN 60837) that secure the panel assembly to the enclosure.
2. Lift the panel by first grasping the regulator knob and Port 1, then grasping under the panel edges. Ensure that the flexible pressure cable does not catch or snag.
3. Gently set the panel assembly on a bench top. It can be rested on the panel bottom and regulator edge with the panel tilted at an angle from its vertical.

3.2.2 Nitrogen Cylinder Assembly Removal (PN 65622)

Condec strongly recommends that the internal nitrogen supply cylinder be pressure-tested and re-certified every five years from date cylinder was manufactured per U.S. DOT. 3AL Regulation, Title 49 CFR, parts 173 and 178.

Tools required: 7/16" wrench
Phillips screwdriver
1-1/8" wrench
3/8" wrench

Procedure:

1. Vent any remaining gas from the cylinder to atmosphere.
2. Remove front panel from its enclosure as described in Section 3.2.1 and carefully set on a bench top.
3. Using a 7/16" wrench, remove flexible tubing (PN 65384) from the cylinder elbow.
4. Remove the 4 mounting nuts and 2 clamps for the cylinder.
5. Remove the cylinder assembly.
6. If installing a new cylinder, remove the fitting/elbow assembly and Teflon seal and inspect for any damage. If there is no damage, reuse these items on the new cylinder.

3.2.3 Installing New Nitrogen Cylinder Assembly (PN 65622)

Tools required: 7/16" wrench
Phillips screwdriver
1-1/8" wrench
3/8" wrench
4" of 1/4"-wide Teflon tape (PN 60575)
4" of 1/2"-wide Teflon tape (PN 60911)
tube of fluorinated Krytox grease (PN 55593)
bottle of liquid leak gas detector (PN 64781)

1. Install the Teflon O-ring (PN 59217), fitting (PN 59287), and elbow (PN 59874) on the new cylinder (PN 65458) and tighten until snug. Place a small amount of Krytox grease on both sides of Teflon O-ring prior to installation. If installing new parts, Teflon tape is required.
2. Mount the cylinder in the enclosure making sure that the elbow fitting tube hole is correctly oriented toward the top of case.
3. Install the two clamps (PN 65385) and 4 mounting nuts (PN 61439).
4. Install the flexible tubing section (PN 65384), tightening fitting nut 1/4 turn from finger-tight using a 7/16" wrench.
5. Fill the cylinder to approximately 1000 PSIG and check all fittings for leaks. See Section 2.1 on page 3 for cylinder refilling procedure.

3.2.4 ORION 2C Manifold Removal (PN 58822)

Tools required: Phillips screwdriver
11/32" wrench or nutdriver
.061" hex wrench
adjusting screwdriver (small flat blade)
11/32" wrench (thin)
7/16" wrench

NOTE: See Table 3-2 on page 13 and Figure 3-3 on page 15 for additional parts information.

1. Vent any remaining gas from the nitrogen cylinder to atmosphere.
2. Remove front panel from its enclosure as described in Section 3.2.1 on page 5, and place unit on a bench top.
3. Remove the tubing sections from Port 1 fitting (PN 65485) and Port 2 fitting (PN 59833) on the Orion 2C using a 7/16" wrench.
4. Remove the tubing sections from the VENT and FILL PORT inlet fittings, (PN 59833), on the Orion 2C using a 7/16" wrench.
5. Remove the panel knobs from the *PRESSURE*, *VERNIER*, and *VENT* valves using the .061" hex wrench.
6. Loosen and remove the 2 panel screws (PN 60837) from the panel front that secure the manifold to the panel.
7. Remove the Orion 2C manifold.

3.2.5 ORION 2C Manifold, Valve Seat Removal

Tools required: A/R solvent (de-natured alcohol)
socket wrench
3/4" socket
female socket (65581)
needle housing socket (65580)
isolation valve needle housing socket (PN 59793)
hex wrench (.061")
torque wrench
needle-nose pliers
electric hand drill
No. 43 drill bit
No. 4-40 tap
tap handle
small hammer

NOTE: See Table 3-2 on page 13 and Figure 3-3 on page 15 for additional parts information.

1. Secure the manifold by its center portion, in a bench vise, with the valve knobs pointing upward.
2. Using the .061" hex wrench, loosen and remove the knob inserts (4) from the pressure and vent valve stems.
3. Loosen the 3/4" locknuts (1) on the pressure and vent valve threaded needle housings (10).
4. Using the needle housing socket (65580) and torque wrench, loosen and remove the needle/housing assembly (10, 1).
5. To disassemble the isolation valve, first remove the valve needle (18) by turning the gear clockwise.
6. Loosen and remove the valve housings (19) using the isolation valve housing removal socket (59793) female socket (65581) and torque wrench.
7. Remove the valve stem seats (8) and valve needle seats (9) using the needle-nose pliers.
8. Remove the inner and outer O-rings (28, 27) and back-up rings (31, 30) from the valve stem seats and wash all parts in solvent (de-natured alcohol).
9. To remove valve seats (7) from either the pressure, vent or isolation valves, try blowing compressed air through the inlet and outlet fittings. Otherwise, the center holes will have to be drilled and a tap used to extract the seat.
10. Using the electric hand drill with the No. 43 bit, carefully drill out the seat hole, ensuring that the drill does not touch the hole in the manifold housing directly beneath the seat.
11. Blow out any chips from the seat area using compressed air.
12. While holding the 4-40 tap steady and perpendicular to the seat, slowly turn until the tap starts to engage the seat.
13. When the tap has engaged into the seat, use a small hammer and gently knock upward against the tap handle to extract the seat.
14. After the seat has been removed, blow any remaining chips from the seat area.

3.2.6 ORION 2C Manifold, Vernier Control Disassembly

Tools required: A/R solvent (de-natured alcohol)
 1-1/4" wrench
 screwdriver (flat-blade)
 socket wrench
 isolation valve socket (PN 59793)
 female socket (PN 65581)

1. With the manifold housing mounted in a vise, turn the vernier shaft (14) clockwise until the piston is bottomed.
2. Loosen and remove the end cap (13) using a 1-1/4" wrench. At certain points during removal the end cap will appear to lock up. If this occurs, rotate the shaft clockwise until the end cap is free to turn.
3. Remove the O-ring (29) from the end cap.
4. Remove the self-sealing screw (36) that acts as the piston key.
5. Extract the piston (15) by partially screwing in the threaded end of the shaft and pulling.
6. Remove the O-ring (32) from the piston groove.
7. To disassemble the end cap/shaft assembly, mount the end cap in the vise.
8. Loosen and remove the locknut (20) using the isolation valve housing socket (PN 59793), female socket (65581), and socket wrench.
9. Loosen and remove the end bushing (12) using the same socket. Remove the shaft (14). Remove the mylar bearing washers (41 or 42) from both sides of the shaft flange.
10. Use a small pick or screwdriver to remove the O-ring (27) from the inner groove of the end cap (13).
11. Wash all parts in solvent and blow dry with compressed air.

3.2.7 ORION 2C Manifold, Vernier Control Reassembly

Tools required: tube fluorinated Krytox grease (PN 55593)
1-1/4" wrench
screwdriver (flat-blade)
socket wrench
isolation valve socket (PN 59793)
female socket (PN 65581)

1. Coat all new O-rings with fluorinated Krytox grease before installing.
2. Install the small O-ring (27) into the end cap inner groove.
3. Add mylar washers (41) or (42) to each side of shaft (14).
NOTE: Part number and quantity will vary. Washers are used to adjust vertical play in shaft (14). Try one item (41) on each side to start.
4. Apply a small amount of fluorinated Krytox grease to the shaft threads and install the shaft (14) into the end cap.
5. Install the end bushing (12) and tighten until snug using the isolation valve socket, female socket, and wrench.
6. Feel vertical motion of shaft (14). If motion exists add thicker washer at step 3, otherwise continue to step 7.
7. Install the locknut (20) and tighten until snug using the isolation valve socket, female socket, and wrench.
8. Install the O-ring (32) in the piston groove and install the piston (15) into the vernier cavity. Ensure that the piston keyway is facing the hole into which the self-sealing screw is assembled.
9. Install the self-sealing screw (36) and tighten until snug.
10. Apply a thin coat of grease and install the O-ring (29) on the end cap/shaft assembly, install into manifold and tighten until snug.

3.2.8 ORION 2C Manifold, Valve Seat Installation

Tools required: needle-nose pliers
tube fluorinated Krytox grease (PN 55593)
No. 43 drill
A/R solvent (de-natured alcohol)
hex wrench (.061")
torque wrench
socket wrench
3/4" socket
needle housing socket (PN 65580)
isolation valve socket (PN 59793)
female socket (PN 65581)

NOTE: See Table 3-2 on page 13 and Figure 3-3 on page 15 for additional parts information.

1. Install a new seat (7) by placing it into the seat well with the needle-nose pliers. Ensure that the seat is centered within the cavity and gently tap it with a blunt end of a drill bit to install.
2. Install the valve needle seat (9) with the smaller diameter end facing outward.
3. Install new O-rings (28, 27) inside and outside of the valve stem seat. Coat all O-rings and back-up rings (30, 31) with fluorinated Krytox grease before installation. Make sure that the rings are installed in the proper order.
4. Install the valve stem seat (8) by grasping the small diameter end with the needle-nose pliers and positioning in the valve cavity, then gently pushing with the blunt end of a drill bit.
5. For the two outer valves, disassemble the valve needle (11) from its housing (10) and check for any burrs or dirt on the threads which might interfere with smooth operation.
6. Clean both the needle (11) and housing (10) in solvent, dry the parts and apply a small amount of fluorinated Krytox grease to the needle threads before reassembly.
7. Assemble the needle into the valve housing and turn it until it stops.
8. Reinstall the needle/housing assembly into the valve cavity until finger tight.

9. Mount the manifold body (16) in a vise. For the pressure and vent valves only, torque the needle/housing assembly to 325 in-lb. using the needle housing socket (PN 65580).
10. Install the housing lock nuts (1) onto the housing (10) and tighten until snug with the 3/4" socket.
11. Install the knob insert (4) over the needle shaft, align the set screws with the indents and tighten with the .061" hex wrench.
12. Install the needle housing (19) and tighten until snug using the housing installation socket (PN 59793), female socket (PN 65581) and torque wrench. (There is no specified torque, so use care when tightening so as not to break the socket nibs.)
13. Apply a small amount of fluorinated Krytox grease to the threads of the isolation valve needles (18) and install into the valve by turning counter-clockwise. Rotate the gear until the needle just stops at the seat.

3.2.9 ORION 2C Manifold, Panel Installation

Tools required: 7/16" wrench
Phillips screwdriver
hex wrench (.061")

1. With the panel facing down against the bench, install the manifold with the Port 1 and Port 2 side facing the panel bottom. Install the two mounting screws (PN 60837) from the panel front and tighten until snug.
2. If not already done, remove the panel knobs from the *PRESSURE*, *VERNIER*, and *VENT* valves using the .061" hex wrench.
3. Install the panel knob onto the vernier valve shaft. Align the set screws with the indentations and tighten until snug using the .061" hex wrench.
4. To install and adjust the *PRESSURE* and *VENT* valve knobs, follow the procedure in Section 3.2.10.
5. Install the tubing sections from, Port 1 fitting (PN 65485) and Port 2 fitting (PN 59833) on the Orion 2C using a 7/16" wrench.
6. Install the tubing sections from the vent and pressure inlet fittings (PN 59833) on the Orion 2C using a 7/16" wrench.
7. Install all tubing sections that attach to the manifold.

3.2.10 ORION 2C Manifold, Valve Adjustment Procedure

Tools required: customer-supplied electronic calibrator
hex wrench (.050")
hex wrench (.061")
bottle of leak gas detector (PN 64781)

1. Fill the cylinder to approximately 1000 PSIG and check all fittings for leaks. See Section 2.1 on page 3 for cylinder filling procedure.
2. Using a .050" hex wrench, loosen the set screw on the lock nut and turn the lock nut clockwise to its stop.
3. Check to see that the knob insert is securely fastened to the valve shaft. If it is loose, re-tighten the set screws with the .061" hex wrench.
4. Close the *PRESSURE* valve by turning the knob insert clockwise until the valve is slightly snug.
5. Connect customer supplied electronic calibrator.
6. Increase the supply pressure to between 500 and 1000 PSIG.
7. Open the *VENT* valve to atmosphere, zero the customer supplied electronic calibrator, then close the *VENT* valve.
8. Slowly open the *PRESSURE* valve by turning counter-clockwise until you notice the displayed pressure increase. Then turn the valve shaft clockwise until the pressure stops rising.
9. Mark a radial line at the 12 o'clock position on the knob insert.
10. Turn the knob insert clockwise to move the mark to the 6 o'clock position.
11. Turn the locknut counter-clockwise until it contacts the bottom of the stop washer. Tighten the set screw on the lock nut with the .050" hex wrench.
12. Install the knob on the knob insert and engage its gear with the smaller isolation valve gear. Turn the

knob clockwise until the isolation valve is slightly snug. *To avoid damage to the seat, do not use excessive torque!*

13. Remove the knob. Align the two set screws with the indentations on the knob insert. Install the knob on the knob insert while engaging the knob gear with the isolation valve gear.
14. Tighten the two set screws with the .061" hex wrench. The *PRESSURE* valve is now adjusted.
15. To adjust the *VENT* valve, follow steps 3 and 4.
16. Close the *VENT* valve knob insert clockwise until slightly snug.
17. With the supply pressure between 500 and 1000 PSIG, open the pressure valve until the indicated pressure stabilizes and then close the *PRESSURE* valve.
18. Slowly turn the *VENT* valve counter-clockwise until the displayed starts to decrease, then turn the knob insert until the indicated stops decreasing.
19. Follow steps 10 through 15. The *VENT* valve is now adjusted.

3.2.11 Pressure Limit Control (PN 65455), Regulator Removal

Tools required: Phillips screwdriver
7/16" wrench
9/16" wrench
A/R Teflon tape (PN's 60911 & 60575)
1/2" socket
1/4" hex wrench

NOTE: See Figure 3-3 on page 15.

1. Vent any remaining gas from the nitrogen cylinder to atmosphere.
2. Remove front panel from its enclosure as described in Section 3.2.1 on page 5, and carefully place on a bench top.
3. Remove regulator knob cap. Remove two screws that secure the round plate.
4. Loosen and remove the locknut using a 1/2" socket while holding the knob. Remove the knob by turning counter-clockwise
5. Remove all tubing sections that connect to the regulator inlet and outlet fittings.
6. Loosen the mounting collar in the panel rear using a 1/4" hex wrench.
7. Remove the regulator by sliding out from the panel rear.
8. Mount the regulator in a bench vise by the flats in the base.
9. Note the orientation of the inlet and outlet fittings in the regulator. Remove the fittings and any remnants of Teflon tape from the pipe threads.

3.2.12 Pressure Limit Control (PN 65455), Regulator Installation

Tools required: Phillips screwdriver
7/16" wrench
9/16" wrench
A/R Teflon tape (PN's 60911 & 60575)
bottle liquid leak gas detector (PN 64781)

NOTE: See Table 3-2 on page 13 and Figure 3-3 on page 15 for additional parts information.

1. Wrap two layers of Teflon tape on the pipe threads of each fitting and install into the inlet and outlet of the regulator and ensure that each is oriented properly. Use a bench vise when doing this. Insert the new regulator into the panel through hole. Pass the adjusting end through the mounting ring. *Do not tighten cap screw until adjusting knob is installed.*
2. Install the tubing sections to the inlet and outlet fittings.
3. Install the adjusting knob on the threaded shaft by turning clockwise Turn adjusting knob on threaded shaft until bottomed and install locking nut and tighten. Turn knob until it bottoms. Position the regulator so that the bottom of the knob is 1/2" from the panel surface, then tighten the cap screw on the mounting collar.
4. Fill the cylinder to approximately 1000 PSIG and check all fittings for leaks. See Section 2.1 on page 3 for cylinder refilling procedure.

3.2.13 Panel Gage Removal

Tools required: Phillips screwdriver
7/16" wrench
9/16 " wrench

1. Vent any remaining gas from the nitrogen cylinder to atmosphere.
2. Remove front panel from its enclosure as described in Section 3.2.1 on page 5, and carefully place on a bench top.
3. Disconnect the tubing section that connects to the gage fitting.
4. Loosen the two thumb-nuts that hold the gage mounting U-clamp.
5. While gripping the square portion of the gage port with the 9/16" wrench, remove the fitting from the gage.
6. Remove the two thumb-nuts, the mounting U-clamp, and the gage.

3.2.14 Panel Gage Installation

Tools required: Phillips screwdriver
7/16" wrench
9/16 " wrench
A/R 1/4" wide Teflon tape (PN 60575)
bottle liquid leak gas detector (PN 64781)

1. Before installing a new gage, wrap two layers of new Teflon tape on the port.
2. To install the gage, reverse the order of steps 2 through 6 of the "Panel Gage Removal" procedure above.
3. Fill the cylinder to approximately 1000 PSIG and check all fittings for leaks. See Section 2.1 on page 3 for cylinder refilling procedure.

3.2.15 Port 1 & Port 2 Quick-Connect Fitting (PN 55426), Removal and Installation

There is relatively little maintenance that has to be done to the port fitting. Every 2 months, a little coating of Silicone grease should be applied to the inner seal. The pressure cap (PN 55434) should be plugged in whenever the unit is not in use.

Note: For simplest method, apply fluorinated Krytox grease to the outside surface between sealing lip and end of mating quick-disconnect fitting. Vent unit line pressure to atmosphere. Plug quick-connect fitting into applicable testport. Rotate fitting clockwise and counter-clockwise to transfer fluorinated Krytox grease to O-ring seal.

If there is leakage out of the port when the pressure cap is in place, replace the port fitting.

Tools required: Phillips screwdriver
2 3/4" wrenches
9/16 " wrench
A/R Teflon tape (PNs 60911 & 60575)
tube fluorinated grease (PN 55593)
bottle liquid leak gas detector (PN 64781)

1. Vent any remaining gas from the nitrogen cylinder to atmosphere.
2. Remove front panel from its enclosure as described in Section 3.2.1 on page 5, and carefully set on a bench top.
3. Grasp the hex at the panel face with a 3/4" wrench and using a second wrench, turn the port fitting counter-clockwise. The short nipple (PN 59112) may or may not be removed at the same time.
4. If the short nipple remains in the panel fitting, a new port can be installed on it. Remove any remnants of sealing tape and wrap two turns of Teflon tape to the threads.
5. Install the new quick-connect fitting (PN 55426) by turning clockwise
6. If the nipple (PN 59112) is removed along with the old fitting, the nipple cannot be reused. Install a new nipple along with the new port.
7. Fill the cylinder to approximately 1000 PSIG and check all fittings for leaks. See Section 2.1 on page 3 for cylinder refilling procedure.

3.2.16 Port 1, Port 2 and Fill Port Filter (PN 54188)

The port filter is a sintered element filter which is easily removed for inspection and cleaning.

Tools required: Phillips screwdriver
7/16" wrench
9/16 " wrench
A/R solvent (de-natured alcohol)
bottle of liquid leak gas detector (PN 64781)

Port 1 or Port 2 Filter Removal

1. Vent any remaining gas from the nitrogen cylinder to atmosphere.
2. Remove front panel from its enclosure as described in Section 3.2.1 on page 5, and carefully place on a bench top.
3. Loosen and remove the tubing end nut from the tube adapter/reducer fitting (PN 59830). **NOTE:** Use PN 54047 for field replacement.
4. Loosen and remove the tube reducer and remove the filter.
5. Clean the filter (PN 54188) in solvent (de-natured alcohol) and blow-dry with compressed air.

Port 1 or Port 2 Filter Installation

1. To reinstall, reverse the order of steps 2 through 4 of the "Fill Port Filter Removal" procedure above.
2. Fill the cylinder to approximately 1000 PSIG and check all fittings for leaks. See Section 2.1 on page 3 for cylinder refilling procedure.

Fill Port Filter Removal

1. Vent any remaining gas from the nitrogen cylinder to atmosphere.
2. Remove front panel from its enclosure as described in Section 3.2.1 on page 5, and carefully set on a bench top.
3. Loosen and remove the tubing end nuts from the tee fitting (PN 65386).
4. Loosen and remove the input port fitting nut located closest to the port connector fitting (PN 59746).
5. Loosen and remove the port connector fitting, (PN 59746) and the filter. **NOTE:** Use PN 55705 for field replacement of port connector fitting.
6. Clean the filter (PN 54188) in solvent (de-natured alcohol) and blow dry with compressed air.

Fill Port Filter Installation

1. To reinstall, reverse the order of steps 2 through 4 of the "Fill Port Filter Removal" procedure above.
2. Fill the cylinder to approximately 1000 PSIG and check all fittings for leaks. See Section 2.1 on page 3 for cylinder refilling procedure.

3.2.17 Inlet Check Valve (PN 60263) (Nitrogen Fill Port)

Remove the check valve if it does not hold the pressure of the N₂ cylinder. The check valve can be disassembled for cleaning should any debris foul the seat area.

Tools required: Phillips screwdriver
7/16" wrench
9/16 " wrench
A/R 1/2" Teflon tape, PN 60911
5/32" hex wrench
tube fluorinated grease (PN 55593)
bottle liquid leak gas detector (PN 64781)
torque wrench

Check Valve Removal

1. Vent any remaining gas from the nitrogen cylinder to atmosphere.
2. Remove front panel from its enclosure as described in Section 3.2.1 on page 5 and place on a bench top.
3. Loosen and remove the tubing end nuts from the tee fitting (PN 65386).

4. Remove the male reducing adapter/run tee assembly from the check valve.
5. Remove the check valve from the female elbow fitting. Remove any remnants of Teflon tape from the pipe threads. Note direction of flow arrow.

Check Valve Disassembly

1. Remove lock screw from the inlet end (tail of flow arrow) using a 5/32" hex wrench.
2. Force insert out by pushing against poppet with a blunt pin inserted into outlet. Remove poppet and spring and clean in solvent. If any damage to O-ring is noticed, replace check valve (PN 66654). Blow-dry parts before reassembly.

NOTE: Apply a small amount of fluorinated Krytox grease on both sides of O-ring (PN 66654)

3. Reassemble the check valve per as shown in Figure 3-2 on page 14.
4. Torque insert lock screw to 85 inchpounds.

Check Valve Installation

1. Wrap two turns of Teflon tape on the check valve threads.
2. Install the inlet end (end opposite direction flow arrow is pointing) of check valve into the female elbow fitting and tighten until snug.
3. Install the other end of the check valve into the male reducing adapter/run tee assembly.
4. Install and tighten the tubing end nuts from the tee fitting, (PN 65386).
5. Fill the cylinder to approximately 1000 PSIG and check all fittings for leaks. See Section 2.1 on page 3 for cylinder refilling procedure.

3.3 Orion 2C Valve Assembly Parts List

The following table lists the component parts of the Orion 2C.

Ref Number	PN	Description	Quantity
1	57482	Nut,Valve Needle Housing 9/16-18,, Width Across Flats=.75,Thickness=.12	2
2	54401	Locknut	2
3	58079	Knob	2
4	57889	Knob,Insert	2
5	57256	Gear,Spur 40 Teeth	2
6	59233	Gear,Spur 18-tooth	2
7	55896	Valve Seat	4
8	59387	Valve Seat,Stem	4
9	59045	Valve,Needle Seat	4
10	54540	Housing,Valve Needle	2
11	59551	Valve Needle	2
12	57906	Bushing,End	1
13	59378	Cap,End	1
14	59495	Shaft	1
15	59241	Piston	1
16	55714	Body,Dual Valve	1
17	57580	Knob	1
18	55533	Valve Needle	2
19	55159	Housing,Valve Needle	2

Table 3-2. Orion 2C Valve Assembly Parts List

Ref Number	PN	Description	Quantity
20	56784	Locknut,9/16-18UNF-3A, SST	1
21	59845	Plug,Expansion , .1562 +.0000/-.0012 Hole Diameter	14
23	59383	Setscrew,6-32NCx1/8 SST	4
24	58342	Screw,Cap Hex Socket Head, #2-56UNC-3A Purchase per MIL Spec 16995-2	6
25	59322	Setscrew,6-32NCx1/4 SST	6
26	59326	Setscrew,2-56NCx1/8, alloy steel	4
27	55554	O-ring,AS568A Dash No 010, Buna N (Nitrile) 70 Durometer Color Black	5
28	55536	O-ring,AS568A Dash No 002, Buna N (Nitrile) 70 Durometer Color Black	4
29	55573	O-ring,AS568A Dash No 117, Buna N (Nitrile) 70 Durometer Color Black	1
30	60633	Retainer, Packing Backup , Single Turn Tetrafluoroethylene	4
31	55570	Washer,Backing .04 Thick, Tetrafluoroethylene Resin	4
32	55577	O-ring,AS568A Dash No 111, Buna N (Nitrile) 70 Durometer Color Black	1
33	59245	Washer,#8 Screw Size .187, ID x .440 OD x .040 Thick Nylon	2
34	60202	Setscrew, hex	2
35	60837	Screw, MACH Pan Head #10- 32NFx1/2 Phillips Head 300 Series SST	2
36	58976	Screw,Self Sealing,8-32 x 5/8 Modified to Print	1
38	53308	Label Roll,1.25x1.25, Polytrans 3000 Void 3" Core 8" OD	1
41	59878	Spacer .005 thk Mylar	2
42	59880	Spacer .007 thk Mylar	2

Table 3-2. Orion 2C Valve Assembly Parts List

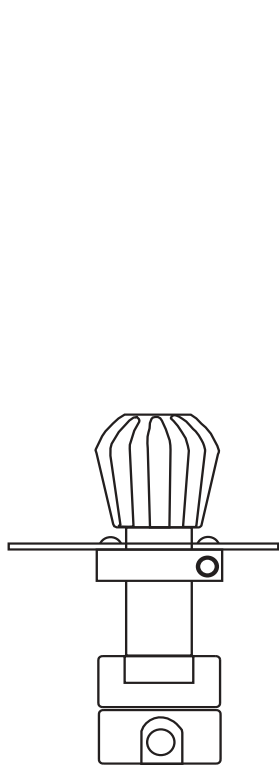

Figure 3-1. Standard Pneumatic Regulator (PN 65455)

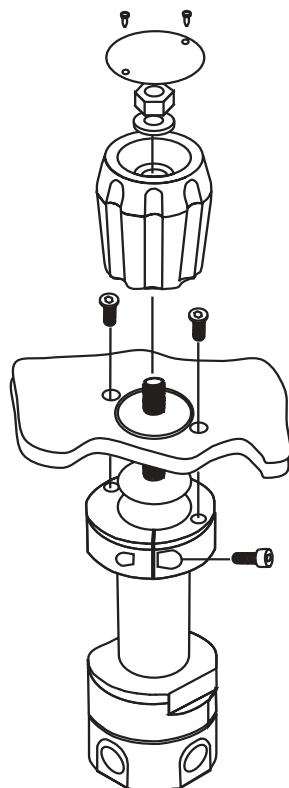
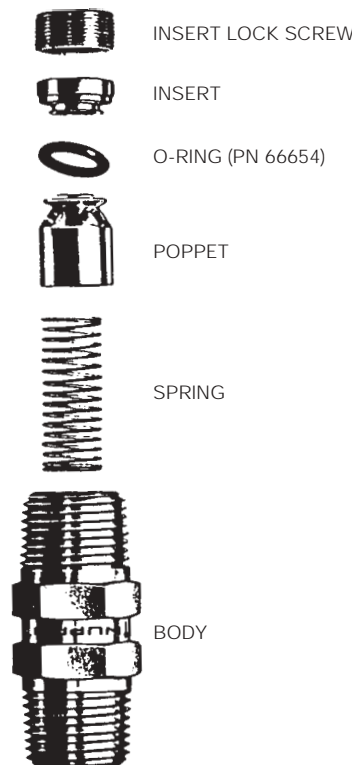

Figure 3-2. Nitrogen Inlet Check Valve Assembly (PN 60263)



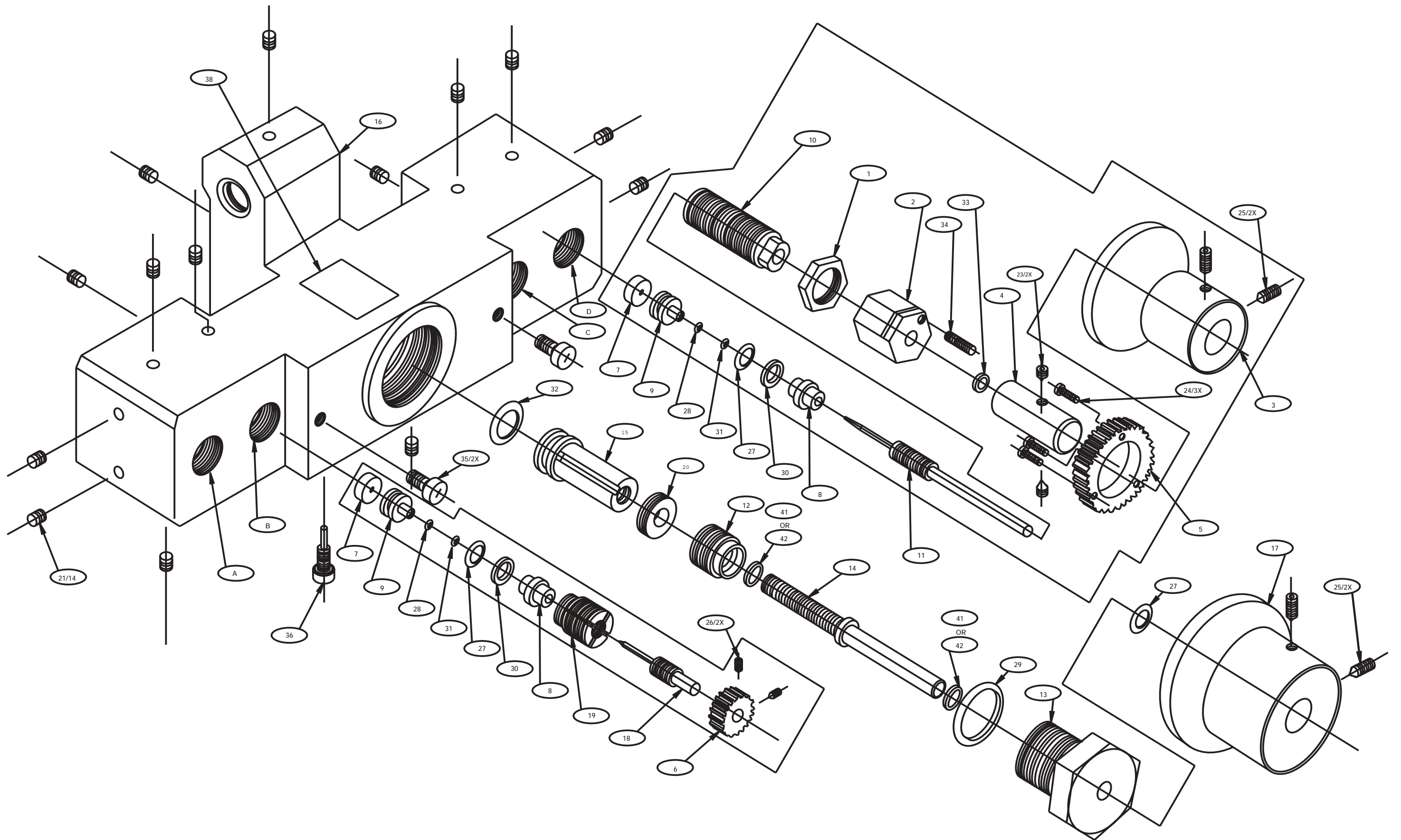

Figure 3-3. Orion 2C, Exploded View

4.0 Specifications

Pressure Specifications:

Pressure range: Based on vendor's electronics
 Available pressure calibrations:
 Gage only, absolute only, or
 gage and absolute
 Overall accuracy: Based on vendor's electronics
 Operating Temperature: +40° to +110°F (+4.4° to +43.3° C)
 Storage Temperature: 0° to +185° F (-17.8° to +85°C)
 Pressure Media: Dry gaseous nitrogen, standard

Internal Pressure Cylinder:

Capacity: 15.2 ft³ N₂ @ 3000 PSIG
 Volume: 133 in³
 Rating: 3000 PSIG
 Test Pressure: 5000 PSIG
 Material: 6061 Aluminum

Pressure Supply Gage:

Size: 2-in. diameter
 Range: 0–4000 PSIG
 Test Pressure: 4000 PSIG

Over-pressure Rupture Disk:

Rating: 3400 PSIG, nominal
 Type: Stainless steel outer case

Pressure Media Filter:

Rating: 20 microns nominal
 Type: Field replaceable

Orion 2C Control Valve:

Type: Micro-metering with replaceable soft seat
 Material: Aluminum body, clear anodized
 Aluminum knobs, black anodized.
 All other parts 300 series stainless steel.

Internal Piping:

Tubing: 1/8 in. O.D., 0.028 in. wall thickness, seamless stainless steel.
 Couplings: 316 stainless steel, Swagelok type

Vent Port:

Style: 1/4" 37° AN male
 Pressure Rating: 3400 PSIG
 Material: 316 series stainless steel

Fill Port:

Style: 1/4" 37° AN flare male
 Pressure Rating: 3400 PSIG rated, 3050 PSIG operating
 Material: 316 series stainless steel

Test Port:

Pressure Rating: 5000 PSIG rated, 3000 PSIG operating
 Material: 300 series stainless steel

Pressure Hose Fittings:

Quantity Supplied: Three; one input, two test port fittings.
 Style: Input fitting: 1/4" 37° female AN swivel one end, 1/8 NPT male on the other
 Test port fittings: Quick disconnect plug (SS) on one end, 1/4" NPT female on the other.
 Input and test port hoses are supplied by customer

Pressure Limit Control Regulator:

Type: Single stage, self-venting, non-bleed
 Pressure Rating: 3000 PSIG max. inlet

Carrying Case:

Type: Aluminum case with latched cover and handle
 Material thickness: 0.090 in., nominal
 Finish: Enamel paint, textured finish
 Color: Gray

Control Panel:

Material: Aluminum (5052-H32)
 Thickness: 0.090 in.
 Finish: Gray enamel paint with black silkscreen nomenclature

Physical Specifications:

Weight: 25 lb
 Case Dimensions: Height: 11.59" (294.4 mm)
 Width: 18.00" (457.2 mm)
 Depth: 7.19" (182.6 mm)

Options:

PN 67248: Test port (output) 5' long hose with quick-disconnect male hose fitting
 PN 78939: Fill port (input) 5' long hose with CGA-580 Cylinder connection fitting and Cheat Seal Pad
 PN 58483: Pressure trap (See literature sheet 58609)
 PN 79423: Hose bag - will fit inside top cover

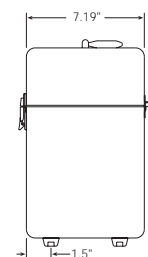
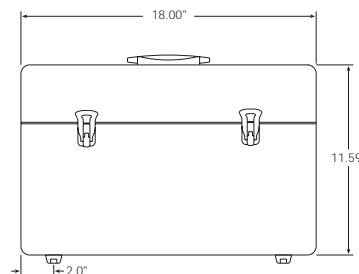
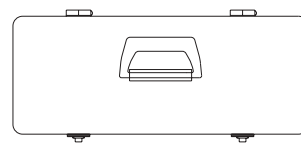

Source 3000 Warranty and Return Policy

If possible, please save original packing material which is specifically designed for the unit. Should it be necessary to ship the unit back to the factory, a suitable shipping container *must* be used along with sufficient packing material. *Do not* put a shipping label on the unit as a "suitable shipping container." Some units have been severely damaged this way. This is a delicate, precision instrument. Any damage incurred because of poor packaging procedures will ultimately result in added service charges and longer turn-around times.



Warning

Vent all pressure lines and the nitrogen cylinder to the atmosphere before shipping.

When factory service is required, send in only the unit for repair. Retain fittings, manuals, etc. at your facility. However, if there is a problem with a particular part, send in that part with the unit.

If a unit is found to be defective, it may be returned to our repair facility at the following address:

CONDEC
3 SIMM LANE
DOOR D, UNIT 2A
NEWTOWN, CT 06470

ATTN: PRESSURE PRODUCTS/REPAIR LAB

Each unit's I.D. plate is stamped with a date code (week/year) prior to shipment. Our warranty is twelve (12) months from that date code and includes repair and/or replacement of the unit at our, Newtown facilities at no charge. Units subjected to abuse or damaged by external influences, are not covered under warranty.

If the unit is found to be out of warranty, an evaluation charge of not less than fifty (U.S.) dollars (\$50.00) will be charged. Please note on any attached paperwork if a repair estimate is required or if there are any other specific instructions.

Please be explicit as to the nature of the problem and/or its symptoms. Your documentation will save needless time and expense. Also, please include a return shipping address (with a street address) and a contact name with fax and telephone numbers. Contact numbers are necessary to provide a job estimate and in case further questions arise at the factory.

Source 3000 Return Material Authorization Form

The repair lab is also equipped to do calibrations on our calibrators and pressure standards. Calibrations include a certification and are traceable to N.I.S.T.

COMPANY NAME:

STREET:

CITY, STATE, ZIP:

TELEPHONE:

FAX:

CONTACT PERSON:

MODEL NUMBER: _____ SERIAL NUMBER: _____

PROBLEM WITH UNIT (PLEASE BE SPECIFIC):

IS THIS A WARRANTY REPAIR? () YES () NO

SHIP TO Address:

COMPANY NAME:

STREET:

CITY, STATE, ZIP:

ATTN:

CONDEC • 3 SIMM LANE • DOOR D, UNIT 2A • NEWTOWN, CT 06470

ATTN: PRESSURE PRODUCTS/REPAIR LAB

TEL: 888-295-8475 • FAX: 203-364-1556 or 715-234-6967

WEB SITE: www.4condec.com