

Mixed-Signal Oscilloscope

MSO-2000E & MSO-2000EA

PROGRAMMING MANUAL



ISO-9001 CERTIFIED MANUFACTURER

GW INSTEK

September 2016

This manual contains proprietary information which is protected by copyright. All rights are reserved. No part of this manual may be photocopied, reproduced or translated to another language without prior written consent of Good Will Corporation.

The information in this manual was correct at the time of printing. However, Good Will continues to improve products and reserves the right to change specifications, equipment, and maintenance procedures at any time without notice.

Windows is a registered trademark of Microsoft Corporation in the United States and other countries.

Good Will Instrument Co., Ltd.

No. 7-1, Jhongsing Rd., Tucheng Dist., New Taipei City 236, Taiwan.

Table of Contents

INTERFACE OVERVIEW	5
Interface Configuration	5
COMMAND OVERVIEW	17
Command Syntax	17
List of Commands in Functional Order ...	19
COMMAND DETAILS	34
Common Commands	36
Acquisition Commands	42
Autoscale Commands	49
Vertical Commands	50
Math Commands	56
Cursor Commands	65
Display Commands	75
Hardcopy Commands	79
Measure Commands	82
Measurement Commands	107
Reference Commands	114
Run Command	117
Stop Command	117
Single Command	117
Force Command	118
Timebase Commands	119
Trigger Commands	122
System Commands	163
Save/Recall Commands	164
Ethernet Commands	169
Time Commands	170
Bus Decode Commands	171
Mark Commands	185

Search Commands	187
Digital Commands	220
Label Commands	228
Segment Commands	236
DVM Commands.....	245
Go_NoGo Commands	247
AWG Commands.....	253
Data Logging Commands.....	272
Remote Disk Commands.....	275
APPENDIX.....	278
Error messages	278
INDEX.....	282

INTERFACE OVERVIEW

This manual describes how to use the MSO-2000E/2000EA's remote command functionality and lists the command details. The Overview chapter describes how to configure the USB and Ethernet remote control interfaces.

Interface Configuration

Configure USB Interface

USB Configuration	PC side connector	Type A, host
	MSO-2000E/2000EA side connector	Type B, device
	Speed	1.1/2.0
	USB Class	CDC (communications device class)

- Panel Operation
1. Press the Utility key.
 2. Press *I/O* from the bottom menu.
 3. Press *USB Device Port* from the side menu and select *Computer*.

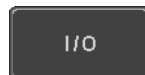

4. Connect the USB cable to the rear panel device port.



5. When the PC asks for the USB driver, select the USB driver included on the accompanying User Manual CD or download the driver from the GW Instek website, www.gwinstek.com, in the MSO-2000E/2000EA Download section. The driver automatically sets the MSO-2000E/2000EA as a serial COM port (Shown as VPO in the PORTS node).

USB Functionality Check

Terminal Application

Invoke a terminal application such as RealTerm.

Set the COM port, baud rate, stop bit, data bit, and parity accordingly.

To check the COM port number and associated port settings, see the Device Manager in the PC. For Windows 7:

Control panel → Hardware and Sound → Device Manager

Example: Configuring RealTerm:

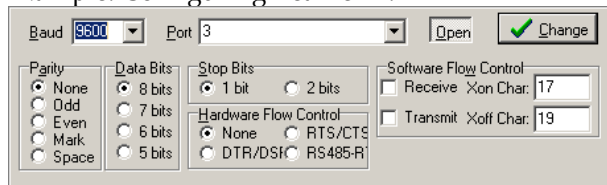

Functionality
Check

Key in this query command via the terminal application.

**idn?*





This should return the Manufacturer, Model number, Serial number, and Firmware version in the following format.

GW,MSO-2202E,PXXXXXX,V1.00

Configure the Ethernet Interface

Ethernet Configuration	MAC Address	Domain Name
	Instrument Name	DNS IP Address
	User Password	Gateway IP Address
	Instrument IP Address	Subnet Mask
		HTTP Port 80 (fixed)

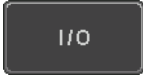
Background The Ethernet interface is used for remote control using a socket server connection. For details, please see the Socket Server section on page 10.

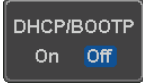
- Panel Operation**
1. Connect the Ethernet cable to the LAN port on the rear panel. 
 2. Press the *Utility* key. 
 3. Press *I/O* from the bottom menu. 
 4. Press *Ethernet* from the side menu. 
 5. Set *DHCP/BOOTP* to *On* or *Off* from the side menu. 



Note

IP addresses will automatically be assigned with DHCP/BOOTP set to on. For Static IP Addresses, DHCP/BOOTP should be set to off.

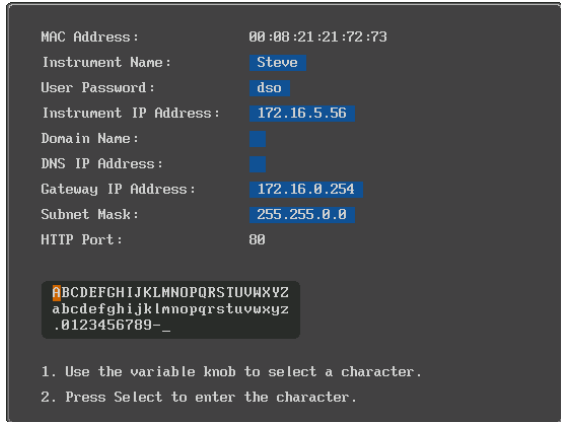

6. Use the *Up* and *Down* arrows on the side menu to navigate to each Ethernet configuration item.

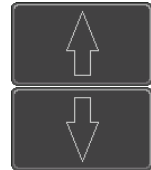

Items MAC Address, Instrument Name, User Password, Instrument IP Address, Domain Name, DNS IP Address, Gateway IP Address, Subnet Mask

Note: HTTP Port is fixed at 80.

7. Use the *Variable* knob to highlight a character and use the *Select* key to choose a character.

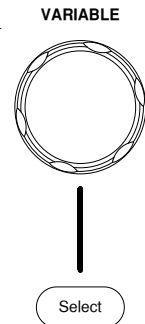

Press *Backspace* to delete a character.



Press *Save Now* to save the configuration. Complete will be displayed when successful.



Configure Socket Server

The MSO-2000E/2000EA supports socket server functionality for direct two-way communication with a client PC or device over LAN. By default, the Socket Server is off.

Configure Socket Server

1. Configure the IP address for the MSO-2000E/2000EA.

Page 8

2. Press the *Utility* key.



3. Press *I/O* from the bottom menu.

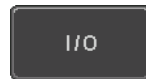

4. Press *Socket Server* from the side menu.

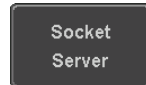

5. Press *Select Port* and choose the port number with the Variable knob.

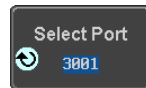

Range 1024~65535

6. Press *Set Port* to confirm the port number.

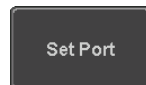

7. The Current Port icon will update to the new port number.



8. Press *Server* and turn the socket server **On**.

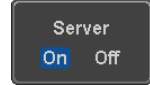

Socket Server Functionality Check

NI Measurement and Automation Explorer To test the socket server functionality, National Instruments Measurement and Automation Explorer can be used. This program is available on the NI website, www.ni.com.

- | | | |
|-----------|--|---|
| Operation | 1. Configure the IP address for the MSO-2000E/2000EA. | Page 8 |
| | 2. Configure the socket port. | Page 10 |
| | 3. Start the NI Measurement and Automation Explorer (MAX) program. Using Windows, press: |  |

Start>All Programs>National Instruments>Measurement & Automation



4. From the Configuration panel access;

My System>Devices and Interfaces>Network Devices

- Right click *Network Devices* and select *Create New Visa TCP/IP Resource...*

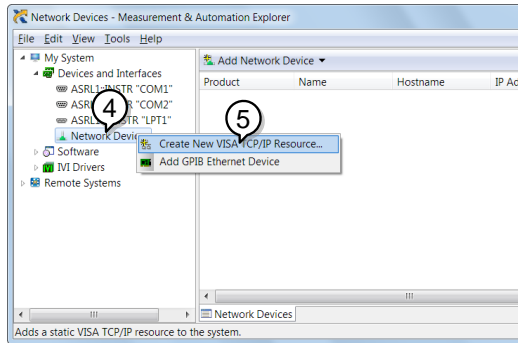

- Select *Manual Entry of Raw Socket* from the popup window.
- Click *Next*.

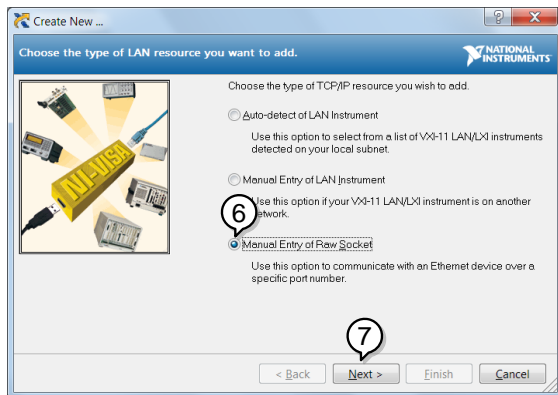

8. Enter the MSO-2000E/2000EA's IP address and socket port number.
9. Click *Validate*.
10. A popup will appear to tell you if a VISA socket session was successfully created.
11. Click *Next*.

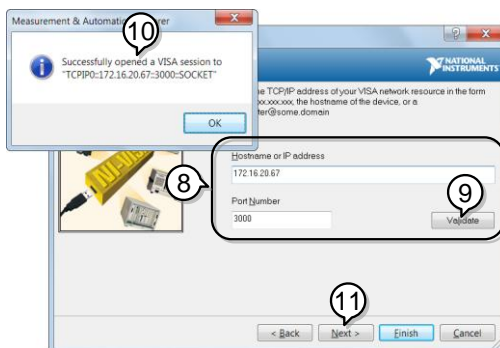

12. Choose an alias for the socket connection if you like.
13. Click *Finish* to finish the configuration.

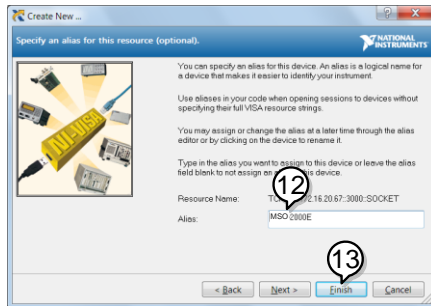

14. The MSO-2000E/2000EA will now appear under Network Devices in the Configuration Panel.

Functionality
Check

15. Click the *Open Visa Test Panel* to send a remote command to the MSO-2000E/2000EA.

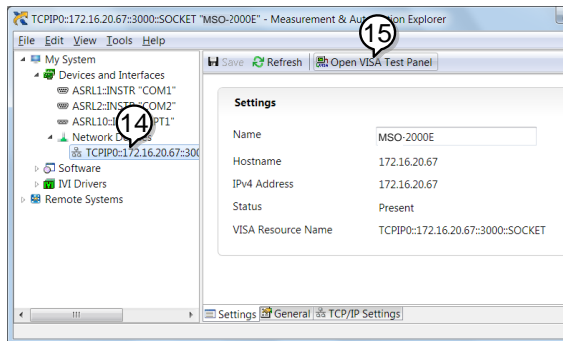

16. Click on the *Configuration* icon.
17. Select the *I/O Settings* tab.
18. Mark the *Enable Termination Character* checkbox.
Make sure the termination character is a line feed (/n, value: xA).
19. Click *Apply Changes*.

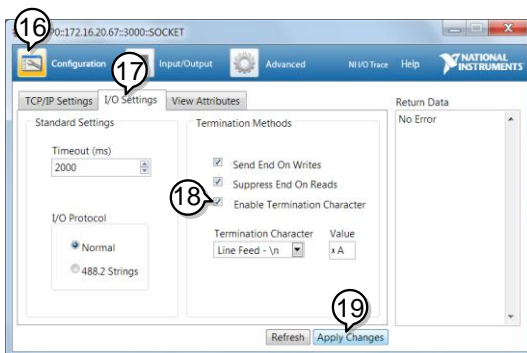

20. Click the *Input/Output* icon.
21. Make sure **IDN?* query is selected in the *Select or Enter Command* drop box.
22. Click on *Query*.
23. The manufacturer, model number, serial number and firmware version will be displayed in the buffer. For example:
GW,MSO-2202E,PXXXXXX,V1.00

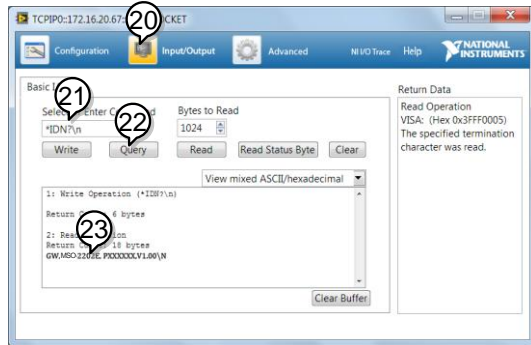

SHORT :TIM:SCAL? :TIM:SCAL?

Command format :TIMbase:SCALE <NR3>LF

1: command header
 2: single space
 3: parameter
 4: message terminator

Parameter	Type	Description	Example
	<Boolean>	boolean logic	0, 1
	<NR1>	Integers	0, 1, 2, 3
	<NR2>	floating point	0.1, 3.14, 8.5
	<NR3>	floating point with an exponent	4.5e-1, 8.25e+1
	<NRf>	any of NR1, 2, 3	1, 1.5, 4.5e-1

Message terminator LF line feed code

Note Commands are non-case sensitive.

List of Commands in Functional Order

Common	*IDN?	36
	*LRN?	36
	*SAV	37
	*RCL	37
	*RST	38
	*CLS	38
	*ESE	38
	*ESR	39
	*OPC	39
	*SRE	40
*STB	40	
Acquisition	:ACQuire:AVERAge	42
	:ACQuire:MODE	43
	:ACQuire<X>:MEMory?	43
	:ACQuire:FILTer:SOURce	45
	:ACQuire:FILTer	46
	:ACQuire:FILTer:FREQuency	46
	:ACQuire:FILTer:TRACking	46
	:ACQuire<X>:STATe?	47
	:ACQuire:INTERpolation	47
	:ACQuire:RECOrdlength	47
:HEADer	48	
Autoscale	:AUTOSet	49
	:AUTORSET:MODE	49

Vertical Scale	:CHANnel<X>:BWLimit.....	50
	:CHANnel<X>:COUPling	51
	:CHANnel<X>:DESKew	51
	:CHANnel<X>:DISPlay	51
	:CHANnel<X>:EXPand	52
	:CHANnel<X>:IMPedance?.....	52
	:CHANnel<X>:INVert	53
	:CHANnel<X>:POSition	53
	:CHANnel<X>:PROBe:RATio	54
	:CHANnel<X>:PROBe:TYPe.....	54
	:CHANnel<X>:SCALE	54
<hr/>		
Math	:MATH:DISP	56
	:MATH:TYPe.....	57
	:MATH:DUAL:SOURce<X>	57
	:MATH:DUAL:OPERator	57
	:MATH:DUAL:POSition.....	58
	:MATH:DUAL:SCALE.....	58
	:MATH:FFT:SOURce	59
	:MATH:FFT:MAG	59
	:MATH:FFT:WINDow.....	59
	:MATH:FFT:POSition	60
	:MATH:FFT:SCALE	60
	:MATH:FFT:HORizontal:SCALE.....	61
	MATH:FFT:HORizontal:POSition.....	61
	:MATH:DEFine	61
	MATHVAR?	62
	MATHVAR:VAR<X>	63
	:MATH:ADVanced:POSition	63
	:MATH:ADVanced:SCALE	63
<hr/>		
Cursor	:CURSor:MODE	66
	:CURSor:SOURce.....	66
	:CURSor:HUNI	67
	:CURSor:HUSE	67
	:CURSor:VUNI	68

	:CURSor:VUSE	68
	:CURSor:DDT	68
	:CURSor:H1Position	69
	:CURSor:H2Position	69
	:CURSor:HDELta	70
	:CURSor:V1Position.....	70
	:CURSor:V2Position.....	70
	:CURSor:VDELta	71
	:CURSor:XY:RECTangular:X:POSition<X>	71
	:CURSor:XY:RECTangular:X:DELta	71
	:CURSor:XY:RECTangular:Y:POSition<X>	72
	:CURSor:XY:RECTangular:Y:DELta	72
	:CURSor:XY:POLar:RADIUS:POSition<X>.....	72
	:CURSor:XY:POLar:RADIUS:DELta	73
	:CURSor:XY:POLar:THETA:POSition<X>	73
	:CURSor:XY:POLar:THETA:DELta	73
	:CURSor:XY:PRODUct:POSition<X>	74
	:CURSor:XY:PRODUct:DELta.....	74
	:CURSor:XY:RATio:POSition<X>	74
	:CURSor:XY:RATio:DELta	75
<hr/>		
Display	:DISPlay:INTensity:WAVEform.....	75
	:DISPlay:INTensity:GRATICule.....	76
	:DISPlay:INTensity:BACKLight	76
	:DISPlay:INTensity:BACKLight:AUTODim:ENABle	76
	:DISPlay:INTENSITY:BACKLight:AUTODim:TIME	77
	:DISPlay:PERSiStence	77
	:DISPlay:GRATICule	78
	:DISPlay:WAVEform.....	78
	:DISPlay:OUTPut	78

Hardcopy	:HARDcopy:START	79
	:HARDcopy:MODE	79
	:HARDcopy:PRINTINKSaver	80
	:HARDcopy:SAVEINKSaver	80
	:HARDcopy:SAVEFORMat	81
	:HARDcopy:ASSIGN.....	81
<hr/>		
Measure	:MEASure:GATing.....	83
	:MEASure:SOURce	83
	:MEASure:METHod	84
	:MEASurement:REFLevel:PERCent:HIGH	84
	:MEASurement:REFLevel:PERCent:LOW	85
	:MEASurement:REFLevel:PERCent:MID	85
	:MEASurement:REFLevel:PERCent:MID2	85
	:MEASure:FALL.....	86
	:MEASure:FOVShoot.....	86
	:MEASure:FPreshoot	87
	:MEASure:FREQuency	87
	:MEASure:NWIDth	88
	:MEASure:PDUTy	88
	:MEASure:PERiod	89
	:MEASure:PWIDth	89
	:MEASure:RISe	90
	:MEASure:ROVShoot.....	90
	:MEASure:RPreshoot.....	91
	:MEASure:PPULSE.....	92
	:MEASure:NPULSE	92
	:MEASure:PEDGE	93
	:MEASure:NEDGE	93
	:MEASure:AMPlitude.....	94
	:MEASure:MEAN	94
	:MEASure:CMean	95
	:MEASure:HIGH.....	96
	:MEASure:LOW.....	96
	:MEASure:MAX.....	97

	:MEASure:MIN	97
	:MEASure:PK2PK	98
	:MEASure:RMS	98
	:MEASure:CRMS	99
	:MEASure:AREa	100
	:MEASure:CARea	100
	:MEASure:FRRDelay	101
	:MEASure:FRFDelay.....	101
	:MEASure:FFRDelay.....	102
	:MEASure:FFFDelay.....	103
	:MEASure:LRRDelay	103
	:MEASure:LRFDelay.....	104
	:MEASure:LFRDelay.....	104
	:MEASure:LFFDelay.....	105
	:MEASure:PHAsE.....	106

Measurement	:MEASUrement:MEAS<X>:SOURCE<X>	107
	:MEASUrement:MEAS<X>:TYPe.....	108
	:MEASUrement:MEAS<X>:STATE	108
	:MEASUrement:MEAS<X>:VALue.....	109
	:MEASUrement:MEAS<X>:MAXimum	110
	:MEASUrement:MEAS<X>:MEAN	111
	:MEASUrement:MEAS<X>:MINimum	111
	:MEASUrement:MEAS<X>:STDdev	112
	:MEASUrement:STATIstics:MODE	113
	:MEASUrement:STATIstics:WEIghting	113
	:MEASUrement:STATIstics	113

Reference	:REF<X>:DISPlay.....	114
	:REF<X>:TIMebase:POSition	114
	:REF<X>:TIMebase:SCALE	115
	:REF<X>:OFFSet	115
	:REF<x>:SCALE	116

Run	:RUN	117
-----	------------	-----

Stop	:STOP	117
<hr/>		
Single	:SINGle	117
<hr/>		
Force	:FORCe.....	118
<hr/>		
Timebase	:TIMebase:EXPand	119
	:TIMebase:POSition	119
	:TIMebase:SCALE	119
	:TIMebase:MODE.....	120
	:TIMebase:WINDow:POSition	120
	:TIMebase:WINDow:SCALE	121
<hr/>		
Trigger	:TRIGger:FREQUency.....	124
	:TRIGger:TYPe	124
	:TRIGger:SOURce	125
	:TRIGger:COUPLE.....	125
	:TRIGger:NREJ	126
	:TRIGger:MODE.....	126
	:TRIGger:HOLDoff.....	126
	:TRIGger:LEVel.....	127
	:TRIGger:HLEVel	127
	:TRIGger:LLEVel.....	128
	:TRIGger:EDGE:SLOP	128
	:TRIGger:DElay:SLOP	128
	:TRIGger:DElay:TYPe.....	129
	:TRIGger:DElay:TIME.....	129
	:TRIGger:DElay:EVENT.....	130
	:TRIGger:DElay:LEVel	130
	:TRIGger:PULSEWidth:POLarity	130
	:TRIGger:RUNT:POLarity	131
	:TRIGger:RUNT:WHEn.....	131
	:TRIGger:RUNT:TIME	132
:TRIGger:RISEFall:SLOP	132	
:TRIGger:RISEFall:WHEn	132	

:TRIGger:RISEFall:TIME.....	133
:TRIGger:VIDeo:TYPe	134
:TRIGger:VIDeo:FIELD	134
:TRIGger:VIDeo:LINE.....	135
:TRIGger:VIDeo:POLarity	135
:TRIGger:PULSe:WHEn	135
:TRIGger:PULSe:TIME	136
:TRIGger:TIMEOut:WHEn	136
:TRIGger:TIMEOut:TIMER	137
:TRIGger:ALTErnate	137
:TRIGger:STATE	138
:TRIGger:EXTErnal:PROBe:TYPe.....	138
:TRIGger:EXTErnal:PROBe:RATio	139
:TRIGger:BUS:TYPe	139
:TRIGger:BUS:THReshold:CH<x>	140
:TRIGger:BUS:B1:I2C:CONDition	140
:TRIGger:BUS:B1:I2C:ADDReSS:MODE.....	141
:TRIGger:BUS:B1:I2C:ADDReSS:TYPe.....	141
:TRIGger:BUS:B1:I2C:ADDReSS:VALue	142
:TRIGger:BUS:B1:I2C:ADDReSS:DIRectioN.....	142
:TRIGger:BUS:B1:I2C:DATA:SIZE	143
:TRIGger:BUS:B1:I2C:DATA:VALue	143
:TRIGger:BUS:B1:UART:CONDition	144
:TRIGger:BUS:B1:UART:RX:DATA:SIZE	145
:TRIGger:BUS:B1:UART:RX:DATA:VALue	145
:TRIGger:BUS:B1:UART:TX:DATA:SIZE.....	146
:TRIGger:BUS:B1:UART:TX:DATA:VALue	146
:TRIGger:BUS:B1:SPI:CONDition	147
:TRIGger:BUS:B1:SPI:DATA:SIZE	148
:TRIGger:BUS:B1:SPI:DATA:MISO:VALue	148
:TRIGger:BUS:B1:SPI:DATA:MOSI:VALue	149
:TRIGger:BUS:B1:CAN:CONDition	150
:TRIGger:BUS:B1:CAN:FRAMeType	150
:TRIGger:BUS:B1:CAN:IDentifier:MODE.....	151
:TRIGger:BUS:B1:CAN:IDentifier:VALue	151

	:TRIGger:BUS:B1:CAN:IDentifier:DIRection	152
	:TRIGger:BUS:B1:CAN:DATA:QUALifier	152
	:TRIGger:BUS:B1:CAN:DATA:SIZE	153
	:TRIGger:BUS:B1:CAN:DATA:VALue	154
	:TRIGger:BUS:B1:LIN:CONDition	154
	:TRIGger:BUS:B1:LIN:DATA:QUALifier	155
	:TRIGger:BUS:B1:LIN:DATA:SIZE	156
	:TRIGger:BUS:B1:LIN:DATA:VALue	156
	:TRIGger:BUS:B1:LIN:ERRTYPE	157
	:TRIGger:BUS:B1:LIN:IDentifier:VALue	158
	:TRIGger:LOGic:INPut:CLOCK:SOURce	158
	:TRIGger:LOGic:INPut:CLOCK:EDGE	159
	:TRIGger:LOGic:FUNCTion	159
	:TRIGger:LOGic:PATtern	160
	:TRIGger:LOGic:PATtern:INPut:D<x>	160
	:TRIGger:LOGic:PATtern:DELTatime	161
	:TRIGger:LOGic:PATtern:WHEn	161
<hr/>		
System	:SYSTem:LOCK	163
commands	:SYSTem:ERRor	163
<hr/>		
Save/Recall	:RECALL:SETUp	164
	:RECALL:WAVEform	164
	:SAVE:IMAGe	165
	:SAVE:IMAGe:FILEFormat	165
	:SAVE:IMAGe:INKSaver	166
	:SAVE:SETUp	166
	:SAVE:WAVEform	167
	:SAVE:WAVEform:FILEFormat	168
<hr/>		
Ethernet	:ETHERnet:DHCP	169
Commands		
<hr/>		
Time Commands	:DATE	170
<hr/>		
Bus Decode	:BUS1	172
Commands	:BUS1:STATE	172

:BUS1:TYPE	172
:BUS1:INPut	173
:BUS1:I2C:ADDRes:RWINClude	173
:BUS1:I2C:SCLK:SOURce	174
:BUS1:I2C:SDA:SOURce	174
:BUS1:UART:BITRate	174
:BUS1:UART:DATABits	175
:BUS1:UART:PARItY	175
:BUS1:UART:PACKEt	175
:BUS1:UART:EOFPAcket	176
:BUS1:UART:TX:SOURce	176
:BUS1:UART:RX:SOURce	177
:BUS1:SPI:SCLK:POLARity	177
:BUS1:SPI:SS:POLARity	177
:BUS1:SPI:WORDSize	178
:BUS1:SPI:BITORder	178
:BUS1:SPI:SCLK:SOURce	178
:BUS1:SPI:SS:SOURce	179
:BUS1:SPI:MOSI:SOURce	179
:BUS1:SPI:MISO:SOURce	179
:BUS1:DISPlay:FORMAt	180
:LISTer:DATA	180
:BUS1:CAN:SOURce	181
:BUS1:CAN:PROBe	181
:BUS1:CAN:SAMPLEpoint	181
:BUS1:CAN:BITRate	182
:BUS1:LIN:BITRate	183
:BUS1:LIN:IDFORmat	183
:BUS1:LIN:POLARity	183
:BUS1:LIN:SAMPLEpoint	183
:BUS1:LIN:SOURce	184
:BUS1:LIN:STANDard	184
<hr/>	
Mark Commands :MARK	185
:MARK:CREATE	185

	:MARK:DELEte	186
<hr/>		
Search	:SEARCH:COpy	188
Commands	:SEARCH:StATE	189
	:SEARCH:TOtAL	189
	:SEARCH:TRIGger:TYPe	189
	:SEARCH:TRIGger:SOuRce.....	190
	:SEARCH:TRIGger:EDGE:SLOP	190
	:SEARCH:TRIGger:LEVel	191
	:SEARCH:TRIGger:HLEVel	191
	:SEARCH:TRIGger:LLEVel	192
	:SEARCH:TRIGger:PULSEWidth:POLarity	192
	:SEARCH:TRIGger:RUnt:POLarity	193
	:SEARCH:TRIGger:RISEFall:SLOP	193
	:SEARCH:TRIGger:PULSe:WHEn.....	194
	:SEARCH:TRIGger:PULSe:TIME.....	194
	:SEARCH:TRIGger:RUnt:WHEn	195
	:SEARCH:TRIGger:RUnt:TIME	195
	:SEARCH:TRIGger:RISEFall:WHEn	196
	:SEARCH:TRIGger:RISEFall:TIME	196
	:SEARCH:TRIGger:BUS:TYPe.....	197
	:SEARCH:TRIGger:BUS:B1:I2C:CONDition	197
	:SEARCH:TRIGger:BUS:B1:I2C:ADDReSS:MODe	198
	:SEARCH:TRIGger:BUS:B1:I2C:ADDReSS:TYPe	198
	:SEARCH:TRIGger:BUS:B1:I2C:ADDReSS:VALue.....	199
	:SEARCH:TRIGger:BUS:B1:I2C:ADDReSS:DIRection200	
	:SEARCH:TRIGger:BUS:B1:I2C:DATA:SIze	200
	:SEARCH:TRIGger:BUS:B1:I2C:DATA:VALue	201
	:SEARCH:TRIGger:BUS:B1:UART:CONDition.....	202
	:SEARCH:TRIGger:BUS:B1:UART:RX:DATA:SIze	203
	:SEARCH:TRIGger:BUS:B1:UART:RX:DATA:VALue..	203
	:SEARCH:TRIGger:BUS:B1:UART:TX:DATA:SIze	204
	:SEARCH:TRIGger:BUS:B1:UART:TX:DATA:VALue..	204
	:SEARCH:TRIGger:BUS:B1:SPI:CONDition.....	205
	:SEARCH:TRIGger:BUS:B1:SPI:DATA:SIze.....	206

	:SEARCH:TRIGger:BUS:B1:SPI:DATa:MISO:VALue	.206
	:SEARCH:TRIGger:BUS:B1:SPI:DATa:MOSI:VALue	.207
	:SEARCH:TRIGger:BUS:B1:CAN:CONDition208
	:SEARCH:TRIGger:BUS:B1:CAN:FRAMeType209
	SEARCH:TRIGger:BUS:B1:CAN:IDentifier:MODE	...209
	:SEARCH:TRIGger:BUS:B1:CAN:IDentifier:VALue	...210
	:SEARCH:TRIGger:BUS:B1:CAN:IDentifier:DIRection	210
	:SEARCH:TRIGger:BUS:B1:CAN:DATa:QUALifier211
	:SEARCH:TRIGger:BUS:B1:CAN:DATa:SIZE212
	:SEARCH:TRIGger:BUS:B1:CAN:DATa:VALue212
	:SEARCH:TRIGger:BUS:B1:LIN:CONDition213
	:SEARCH:TRIGger:BUS:B1:LIN:DATa:QUALifier214
	:SEARCH:TRIGger:BUS:B1:LIN:DATa:SIZE215
	:SEARCH:TRIGger:BUS:B1:LIN:DATa:VALue215
	:SEARCH:TRIGger:BUS:B1:LIN:ERRTYPE216
	:SEARCH:TRIGger:BUS:B1:LIN:IDentifier:VALue217
	:SEARCH:FFTPeak:METHod217
	:SEARCH:FFTPeak:METHod:MPEak218
	:SEARCH:FFTPeak:SINFo219
<hr/>		
Digital	:D<x>:DISPlay220
Commands	:D<x>:POSition220
	:DISPlay:DIGital:HEIght221
	:DIGital:GROUP<x>:THReshold221
	:DIGital:ANALog:A<x>:DISPlay222
	:DIGital:ANALog:A<x>:RATio223
	:DIGital:ANALog:A<x>:POSition223
	:D<x>:MEMory223
	:DIGital:MEMory225
<hr/>		
Label Commands	:CHANnel<X>:LABel228
	:CHANnel<X>:LABel:DISPlay229
	:REF<X>:LABel229
	:REF<X>:LABel:DISPlay230
	:BUS1:LABel231

	:BUS1:LABel:DISPlay	231
	:D<x>:LABel	232
	:D<x>:LABel:DISPlay	233
	:DIGital:ANALog:A<x>:LABel	233
	:DIGital:ANALog:A<x>:LABel:DISPlay	234
	:SET<X>:LABel	235
<hr/>		
Segment	:SEGMENTS:STATE	236
Commands	:SEGMENTS:CURRENT	237
	:SEGMENTS:TOTALNUM	237
	:SEGMENTS:TIME	238
	:SEGMENTS:DISPALL	238
	:SEGMENTS:MEASURE:MODE	238
	:SEGMENTS:MEASURE:PLOT:SOURCE	239
	:SEGMENTS:MEASURE:PLOT:DIVIDE	239
	:SEGMENTS:MEASURE:PLOT:SELECT	240
	:SEGMENTS:MEASURE:PLOT:RESULTS	240
	:SEGMENTS:MEASURE:TABLE:SOURCE	241
	:SEGMENTS:MEASURE:TABLE:SELECT	241
	:SEGMENTS:MEASURE:TABLE:LIST	242
	:SEGMENTS:MEASURE:TABLE:SAVE	242
	:SEGMENTS:SAVE	242
	:SEGMENTS:SAVE:SOURCE	243
	:SEGMENTS:SAVE:SELECT:START	243
	:SEGMENTS:SAVE:SELECT:END	244
<hr/>		
DVM Commands	:DVM:STATE	245
	:DVM:SOURCE	245
	:DVM:MODE	246
	:DVM:VALUE	246
<hr/>		
Go-NoGo	:GONOGO:CLEAR	247
Commands	:GONOGO:EXECUTE	247
	:GONOGO:FUNCTION	248
	:GONOGO:NGCOUNT	248

	:GONogo:NGDefine	248
	:GONogo:SOURce	249
	:GONogo:VIOLation	249
	:GONogo:SCRipt	249
	:TEMPlate:MODE	250
	:TEMPlate:MAXimum	250
	:TEMPlate:MINimum	250
	:TEMPlate:POSition:MAXimum	251
	:TEMPlate:POSition:MINimum	251
	:TEMPlate:SAVe:MAXimum	251
	:TEMPlate:SAVe:MINimum	252
	:TEMPlate:TOLerance	252
	:TEMPlate:SAVe:AUTO	252

AWG Commands	:AWG<x>:AMPlitude	254
	:AWG<x>:FREQuency	254
	:AWG<x>:FUNCTion	255
	:AWG<x>:OFFSet	256
	:AWG<x>:OUTPut:LOAD:IMPEDance	256
	:AWG<x>:OUTPut:STATE	256
	:AWG<x>:PHase	257
	:AWG<x>:PULSe:DUTYcycle	257
	:AWG<x>:RAMP:SYMmetry	257
	:AWG<x>:MODulation:STATE	258
	:AWG<x>:MODulation:TYPE	258
	:AWG<x>:MODulation:AM:DEPth	258
	:AWG<x>:MODulation:AM:FREQ	259
	:AWG<x>:MODulation:AM:SHApe	259
	:AWG<x>:MODulation:AM:PHase	259
	:AWG<x>:MODulation:AM:DUTYcycle	260
	:AWG<x>:MODulation:AM:SYMmetry	260
	:AWG<x>:MODulation:AM:RATE	260
	:AWG<x>:MODulation:FM:DEV	261
	:AWG<x>:MODulation:FM:FREQ	261
	:AWG<x>:MODulation:FM:SHApe	262

:AWG<x>:MODulation:FM:PHase	262
:AWG<x>:MODulation:FM:DUTYcycle.....	263
:AWG<x>:MODulation:FM:SYMmetry	263
:AWG<x>:MODulation:FM:RATE.....	263
:AWG<x>:MODulation:FSK:FREQ	264
:AWG<x>:MODulation:FSK:RATE.....	264
:AWG<x>:SWEep:STATE	265
:AWG<x>:SWEep:TYPe	265
:AWG<x>:SWEep:START	265
:AWG<x>:SWEep:STOP	266
:AWG<x>:SWEep:TIME.....	266
:AWG<x>:SWEep:SPAN	266
:AWG<x>:SWEep:CENTer	267
:AWG<x>:ARBitrary:EDIT:NUMPOINT	267
:AWG<x>:ARBitrary:EDIT:FUNCTion	267
:AWG<x>:ARBitrary:SAVe:WAVEform.....	268
:AWG<x>:ARBitrary:LOAD:WAVEform.....	268
:AWG<x>:ARBitrary:EDIT:COpy	269
:AWG<x>:ARBitrary:EDIT:CLear	269
:AWG<x>:ARBitrary:EDIT:LINE	270
:AWG<x>:ARBitrary:EDIT:SCALE	270
:AWG<x>:ARBitrary:EDIT:POINT.....	270
:AWG<x>:ARBitrary:EDIT:POINT:ADD.....	271
:AWG<x>:ARBitrary:EDIT:POINT:DELEte	271

Data Logging	:DATALOG:STATE	272
Commands	:DATALOG:SOURce	272
	:DATALOG:SAVe	273
	:DATALOG:INTerval.....	273
	:DATALOG:DURation.....	274

Remote Disk	:REMOTEDisk:IPADDRESS.....	275
Commands	:REMOTEDisk:PATHName	275
	:REMOTEDisk:USERName	275
	:REMOTEDisk:PASSWord	276

:REMOTEDisk:MOUNT.....	276
:REMOTEDisk:AUTOMount.....	277

C COMMAND DETAILS

The Command details chapter shows the detailed syntax, equivalent panel operation, and example for each command. For the list of all commands, see page 19.

Common Commands	36
Acquisition Commands	42
Autoscale Commands	49
Vertical Commands	50
Math Commands	56
Cursor Commands	65
Display Commands	75
Hardcopy Commands.....	79
Measure Commands	82
Measurement Commands	107
Reference Commands	114
Run Command	117
Stop Command	117
Single Command.....	117
Force Command.....	118
Timebase Commands.....	119
Trigger Commands.....	122
System Commands	163
Save/Recall Commands.....	164
Ethernet Commands	169
Time Commands.....	170
Bus Decode Commands	171
Mark Commands.....	185
Search Commands	187

Digital Commands	220
Label Commands	228
Segment Commands	236
DVM Commands	245
Go_NoGo Commands	247
AWG Commands	253
Data Logging Commands	272
Remote Disk Commands	275

Common Commands

*IDN?	36
*LRN?	36
*SAV	37
*RCL	37
*RST	38
*CLS	38
*ESE	38
*ESR	39
*OPC	39
*SRE	40
*STB	40

*IDN?

→ Query

Description	Returns the manufacturer, model, serial number and version number of the unit.
Syntax	*IDN?
Example	*IDN? GW,MSO-2074E,PXXXXXX,V1.XX

*LRN?

→ Query

Description	Returns the oscilloscope settings as a data string.
Syntax	*LRN?
Example	*LRN? :DISPlay:WAVEform VECTOR;PERSistence 2.400E-01; INTensity:WAVEform 50;INTensity:GRATicule 50;GRATicule FULL;:CHANnel CH1:DISPlay ON;BWLimit FULL;COUPling DC;INVert OFF;POSition -1.600E+00;PROBe:RATio

1.000e+01;PROBe:TYPe VOLTAGE;SCALe 2.000E+01;IMPedance 1E+6;EXPand GROUND;;CHANnel CH2:DISPlay ON;BWLimit FULL;COUPLing DC;INVert OFF;POSition 0.000E+00;PROBe:RATio 1.000e+01;PROBe:TYPe VOLTAGE;SCALe 2.000E+00;IMPedance 1E+6;EXPand GROUND;;CHANnel CH3:DISPlay OFF;BWLimit FULL;COUPLing DC;INVert OFF;POSition 0.000E+00;PROBe:RATio 1.000e+01;PROBe:TYPe VOLTAGE;SCALe 1.000E+00;IMPedance 1E+6;EXPand GROUND;;CHANnel CH4:DISPlay OFF;BWLimit FULL;COUPLing DC;INVert OFF;POSition 0.000E+00;PROBe:RATio 1.000e+01;PROBe:TYPe VOLTAGE;SCALe 1.000E+00;IMPedance 1E+6;EXPand GROUND;;MATH:TYPe FFT;DISP OFF;DUAL:SOURce1 CH1;SOURce2 CH2;OPERator MUL;POSition 0.000E+00;SCALe ?;FFT:SOURce CH1;MAG DB;WINDow HANNING;POSition 2.800E-01;SCALe 2.000E+01;MATH:ADVanced:OPERator DIFF;ADVanced:SOURce CH1;ADVanced:EDIT: SOURce1 CH1;ADVanced:EDIT:S

***SAV**



Description Saves the current panel settings to the selected memory number(setup 1 ~ 20).

Syntax *SAV {1 | 2 | 3 |... | 20}

Example *SAV 1
Saves the current panel settings to Set 1.

***RCL**



Description Recalls a set of panel settings.

Syntax *RCL {1 | 2 | 3 |... | 20}

Example *RCL 1
Recalls the selected setup from Set 1.

***RST**

Set →

Description Resets the MSO-2000E/2000EA (recalls the default panel settings).

Syntax *RST

***CLS**

Set →

Description Clears the error queue.

Syntax *CLS

***ESE**

Set →

→ Query

Description Sets or queries the Standard Event Status Enable register.

Syntax *ESE <NR1>

Query Syntax *ESE?

Return parameter <NR1> 0~255

Bit Weight	Bit#	Weight	Event	Description
	0	1	OPC	Operation Complete Bit
	1	2	RQC	Not used
	2	4	QYE	Query Error
	3	8	DDE	Device Error
	4	16	EXE	Execution Error
	5	32	CME	Command Error
	6	64	URQ	User Request
	7	128	PON	Power On

Example *ESE?

>4

Indicates that there is a query error.

***ESR**

→ **Query**

Description Queries the Standard Event Status (Event) register. The Event Status register is cleared after it is read.

Query Syntax *ESR?

Return parameter <NR1> 0~255

Bit Weight	Bit#	Weight	Event	Description
	0	1	OPC	Operation Complete Bit
	1	2	RQC	Not used
	2	4	QYE	Query Error
	3	8	DDE	Device Error
	4	16	EXE	Execution Error
	5	32	CME	Command Error
	6	64	URQ	User Request
	7	128	PON	Power On

Example *ESR?
 >4
 Indicates that there is a query error.

Set →

***OPC**

→ **Query**

Description The *OPC command sets the OPC bit (bit0) of the Standard Event Status Register when all current commands have been processed.
 The *OPC? Query returns 1 when all the outstanding commands have completed.

Syntax *OPC

Query Syntax *OPC?

Return parameter 1 Returns 1 when all the outstanding commands have completed.

Set →

→ Query

***SRE**

Description Sets or queries the Service Request Enable register. The Service Request Enable register determines which registers of the Status Byte register are able to generate service requests.

Syntax *SRE <NR1>

Query Syntax *SRE?

Parameter/Return parameter <NR1> 0~255

Bit Weight	Bit#	Weight	Event	Description
	0	1		Not used
	1	2		Not used
	2	4		Not used
	3	8		Not used
	4	16	MAV	Message Available Bit
	5	32	ESB	Event Status Bit
	6	64	MSS	Master Summary Bit
	6	64	RQS	Request Service Bit
	7	128		Not used

Example *SRE?
>48
Indicates that the MAVB and ESB bit are both set.

***STB**

→ Query

Description Queries the bit sum of the Status Byte register with MSS (Master summary Status) replacing the RQS bit (bit 6).

Query Syntax *STB?

Return parameter <NR1> 0 ~ 255

Bit Weight	Bit#	Weight	Event	Description
	0	1		Not used
	1	2		Not used
	2	4		Not used
	3	8		Not used
	4	16	MAV	Message Available Bit
	5	32	ESB	Event Status Bit
	6	64	MSS	Master Summary Bit
	6	64	RQS	Request Service Bit
	7	128		Not used

Example *STB?
 >16
 Indicates that the MAV bit is set.

Acquisition Commands

:ACquire:AVERage	42
:ACquire:MODE	43
:ACquire<X>:MEMory?	43
:ACquire:FILTer:SOURce	45
:ACquire:FILTer	46
:ACquire:FILTer:FREQuency.....	46
:ACquire:FILTer:TRACking.....	46
:ACquire<X>:STATe?	47
:ACquire:INTERpolation	47
:ACquire:RECOrdlength.....	47
:HEADer	48

:ACquire:AVERage

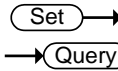

Description	Selects or returns the number of waveform acquisitions that are averaged in the average acquisition mode.
Syntax	:ACquire:AVERage {<NR1> ?}
Related Commands	:ACquire:MODE
Parameter	<NR1> 2, 4, 8 ,16, 32, 64, 128, 256
Note	Before using this command, select the average acquisition mode. See the example below.
Example	:ACquire:MODE AVERage :ACquire:AVERage 2 Selects the average acquisition mode, and sets the average number to 2.

Set →
 → Query

Description	Selects or returns the acquisition mode.						
Syntax	:ACquire:MODE {SAMPLE PDETECT AVERage ?}						
Related Commands	:ACquire:AVERage						
Parameter	<table style="width: 100%; border-collapse: collapse;"> <tr> <td style="width: 15%; border-right: 1px solid gray;">SAMPLE</td> <td>Sample mode sampling</td> </tr> <tr> <td style="border-right: 1px solid gray;">PDETECT</td> <td>Peak detect sampling</td> </tr> <tr> <td style="border-right: 1px solid gray;">AVERage</td> <td>Average sampling mode</td> </tr> </table>	SAMPLE	Sample mode sampling	PDETECT	Peak detect sampling	AVERage	Average sampling mode
SAMPLE	Sample mode sampling						
PDETECT	Peak detect sampling						
AVERage	Average sampling mode						
Example	:ACquire:MODE PDETECT Sets the sampling mode to peak detection.						

→ Query

Description	Returns the data in acquisition memory for the selected channel as a header + raw data.				
Syntax	:ACquire<X>:MEMory?				
Related Commands	:ACquire:RECOrdlength :HEADer				
Parameter	<X> Channel number (1 to 4)				
Return parameter	<table style="width: 100%; border-collapse: collapse;"> <tr> <td style="width: 15%; border-right: 1px solid gray;"><string></td> <td>Returns acquisition settings followed by raw waveform block data.</td> </tr> <tr> <td style="border-right: 1px solid gray;"><waveform block data></td> <td> <string> Returns the acquisition settings for the selected channel. Format: parameter(1),setting(1);parameter(2),setting(2)...parameter(n),setting(n);Waveform Data; <waveform block data> Header followed by the raw waveform data. </td> </tr> </table>	<string>	Returns acquisition settings followed by raw waveform block data.	<waveform block data>	<string> Returns the acquisition settings for the selected channel. Format: parameter(1),setting(1);parameter(2),setting(2)...parameter(n),setting(n);Waveform Data; <waveform block data> Header followed by the raw waveform data.
<string>	Returns acquisition settings followed by raw waveform block data.				
<waveform block data>	<string> Returns the acquisition settings for the selected channel. Format: parameter(1),setting(1);parameter(2),setting(2)...parameter(n),setting(n);Waveform Data; <waveform block data> Header followed by the raw waveform data.				

Format:

Header: The header (in ASCII) encodes the number of bytes for the header followed by the number of data points in bytes for the raw data.

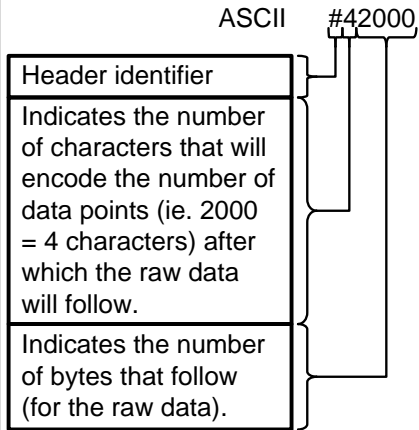

Raw Data:

Each two bytes (in hex) encodes the vertical data of a data point. The data is signed hex data (2's complement, -32768 ~ 32767).

Waveform Raw Data Example:

Header raw data.....

Hex:

23 34 32 30 30 30 00 1C 00 1B 00 1A 00
1A 00 1B

ASCII/Decimal:

#42000 28 27 26 26 27

The actual value of a data point can be calculated with the following formula:
(Decimal value of hex data/AD Factor) * vertical scale.

Note: AD Factor is fixed as 25. The vertical scale is returned with the

acquisition settings that precede the raw data.

For example if the raw data for a point is 001C (=28 decimal) then,
 $(28/25) \times 0.5 = 0.56V$

Example :ACQuire1:MEMory?
 Format,2.0E;Memory Length,10000;IntpDistance,0;
 Trigger Address,4999;Trigger Level,1.160E+01;
 Source,CH1;Vertical Units,V;Vertical Units
 Div,0;Vertical Units Extend
 Div,15;Label,ACK ;Probe Type,0;Probe
 Ratio,1.000e+01;Vertical Scale,5.000e+00;Vertical
 Position,-1.100e+01;Horizontal Units,S;Horizontal
 Scale,5.000E-04;Horizontal Position,0.000E+00;
 Horizontal Mode,Main;SincET Mode,Real
 Time;Sampling Period,5.000e-07;Horizontal Old
 Scale,5.000E-04;Horizontal Old Position,0.000E+00;
 Firmware,V0.99b8;Time,02-Oct-14 17:00:43;
 Waveform Data;
 #520000.....follows waveform block
 data in hex.....

Set →

→ Query

:ACQuire:FILTer:SOURce

Description	Returns the source of the filter.
Syntax	:ACQuire:FILTer:SOURce {CH1 CH2 CH3 CH4 ?}
Parameter/ Return parameter	CH1 ~ CH4 Source channel
Example	:ACQuire:FILTer:SOURce? CH1 Sets the filter source to CH1.

Set →
→ Query

:ACQUIRE:FILTER

Description	Turns the filter on/off or queries its status.	
Syntax	:ACQUIRE:FILTER {ON OFF ?}	
Parameter/ Return parameter	ON	Filter on.
	OFF	Filter off.
Example	:ACQUIRE:FILTER? OFF Indicates that the filter is turned off.	

Set →
→ Query

:ACQUIRE:FILTER:FREQUENCY

Description	Sets or queries the filter frequency.	
Syntax	:ACQUIRE:FILTER:FREQUENCY {DEFAULT <NRf> ?}	
Parameter/ Return parameter	DEFAULT	Sets the filter frequency to the default.
	<NRf>	Manually sets the filter frequency. (1Hz ~ 500MHz)
Example	:ACQUIRE:FILTER:FREQUENCY 1 Sets the filter frequency to 1Hz.	

Set →
→ Query

:ACQUIRE:FILTER:TRACKING

Description	Turns filter tracking on/off or queries its state.	
Syntax	:ACQUIRE:FILTER:TRACKING {ON OFF ?}	
Parameter/ Return parameter	OFF	Tracking off
	ON	Tracking on
Example	:ACQUIRE:FILTER:TRACKING ON Turns filter tracking on.	

:ACquire<X>:STATe? → Query

Description	Returns the status of waveform data.	
Syntax	:ACquire<X>:STATe?	
Parameter	<X>	Channel number (1 to 4)
Return parameter	0	Raw data is not ready
	1	Raw data is ready
Example	:ACquire1:STATe? 0 Returns 0. Channel 1's raw data is not ready. <i>Note: If the oscilloscope changes the acquisition status from STOP to RUN, the status will be reset as zero.</i>	

Set →

:ACquire:INTERpolation → Query

Description	Selects or returns the interpolation mode.	
Syntax	:ACquire:INTERpolation {ET SINC ?}	
Parameter/Return parameter	ET	Equivalent Time interpolation. The MSO-2000E/2000EA doesn't support ET.
	SINC	Sets to SIN(X)/X interpolation
Example	:ACquire:INTERpolation? >SINC Returns SINC as the interpolation mode.	

Set →

:ACquire:RECOrdlength → Query

Description	Sets or queries the record length.	
Syntax	:ACquire:RECOrdlength {<NRf> ?}	
Parameter/Return parameter	<NRf>	Record length. Settable record length: (1e+3 1e+4 1e+5 1e+6 1e+7)

Example :ACQuire:RECOrdlength 1e+3
Sets the record length to 1000 points.

:HEADer

Description Configures whether the returned data of the :ACQuire:MEM query will contain header information or not. It is set to ON by default.

Syntax :HEADer {OFF | ON | ?}

Related Commands :ACQuire<X>:MEMory?

Parameter	ON	Add header information.
	OFF	Don't add header information.

Return parameter Returns the configuration (ON, OFF) for the selected channel.

Example :HEADer ON

Autoscale Commands

:AUTOSet	49
:AUTORSET:MODE	49

:AUTOSet



Description Runs the Autoset function to automatically configure the horizontal scale, vertical scale, and trigger according to the input signal.

Syntax :AUTOSet

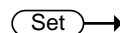

:AUTORSET:MODE

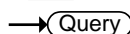

Description Sets the Autoset mode or queries its state.

Syntax :AUTORSET:MODE {FITScreen | ACPriority | ?}

Related Commands :AUTOSet

Parameter/Return parameter	FITScreen	Fit Screen mode
	ACPriority	AC priority mode

Example :AUTORSET?
FITSREEN

Vertical Commands

:CHANnel<X>:BWLimit.....	50
:CHANnel<X>:COUPling	51
:CHANnel<X>:DESKew	51
:CHANnel<X>:DISPlay	51
:CHANnel<X>:EXPand	52
:CHANnel<X>:IMPedance?.....	52
:CHANnel<X>:INVert	53
:CHANnel<X>:POSition	53
:CHANnel<X>:PROBe:RATio	54
:CHANnel<X>:PROBe:TYPe.....	54
:CHANnel<X>:SCALE	54

:CHANnel<X>:BWLimit



Description	Sets or returns the bandwidth limit on/off.	
Syntax	:CHANnel<X>:BWLimit {FULL <NR3> ?}	
Parameter	<X>	Channel 1,2,3,4
	FULL	Full bandwidth
	<NR3>	Sets the bandwidth limit to a pre-defined bandwidth.
		100E+6: 100MHz 20E+6: 20MHz
Return Parameter	<NR3>	Returns the bandwidth.
	Full	Full bandwidth
Example	:CHANnel1:BWLimit 2.000E+07 Sets the channel 1 bandwidth to 20MHz.	

:CHANnel<X>:COUPling
 →
 →

Description	Selects or returns the coupling mode.	
Syntax	CHANnel<X>:COUPling {AC DC GND ?}	
Parameter	<X>	Channel 1,2,3,4
	AC	AC coupling
	DC	DC coupling
	GND	Ground coupling
Return parameter	Returns the coupling mode.	
Example	:CHANnel1:COUPling DC Sets the coupling to DC for Channel 1.	

:CHANnel<X>:DESKew
 →
 →

Description	Sets the deskew time in seconds.	
Syntax	:CHANnel<X>:DESKew { <NR3> ?}	
Parameter	<X>	Channel 1,2,3,4
	<NR3>	Deskew time: -5.00E -11 to 5.00E-11 -50ns to 50 ns. (10 ps /step)
Return parameter	<NR3>	Returns the deskew time.
Example	:CHANnel1:DESKew 1.300E-9 Sets the deskew time to 1.3 nano seconds.	

:CHANnel<X>:DISPlay
 →
 →

Description	Turns a channel on/off or returns its status.	
Syntax	:CHANnel<X>:DISPlay {OFF ON ?}	
Parameter	<X>	Channel 1,2,3,4
	OFF	Channel off
	ON	Channel on

Return Parameter	ON	Channel is on
	OFF	Channel is off

Example :CHANnel1:DISPlay ON
Turns on Channel 1

Set →

→ Query

:CHANnel<X>:EXPand

Description Sets Expand By Ground or Expand By Center for a channel or queries its status.

Syntax :CHANnel<X>:EXPand {GND | CENTER | ?}

Parameter	<X>	Channel 1,2,3,4
	GND	Ground
	CENTER	Center

Return parameter	GND	Expand By Ground
	CENTER	Expand By Center

Example :CHANnel1:EXPand GND
Sets Channel 1 to Expand By Ground.

:CHANnel<X>:IMPedance?

→ Query

Description Returns the impedance of the oscilloscope. (The impedance of the MSO-2000E/2000EA is fixed at 1MΩ)

Syntax :CHANnel<X>:IMPedance?

Parameter	<x>	Channel
	1/2/3/4	CH1/2/3/4

Return parameter <NR3> Returns the impedance value.

Example :CHANnel1:IMPedance?
1.000000E+06
The impedance is 1M ohms.

:CHANnel<X>:INVert



Description	Inverts a channel or returns its status.	
Syntax	:CHANnel<X>:INVert {OFF ON ?}	
Parameter	<X>	Channel 1, 2, 3, 4
	OFF	Invert off
	ON	Invert on
Return parameter	ON	Invert on
	OFF	Invert off
Example	:CHANnel1:INVert ON Inverts Channel 1	

:CHANnel<X>:POSition



Description	Sets or returns the position level for a channel.	
Note	<p>The vertical position will only be set to closest allowed value. The position level range depends on the vertical scale.</p> <p>The scale must first be set before the position can be set.</p>	
Syntax	:CHANnel<X>:POSition { <NRf> ?}	
Parameter	<X>	Channel 1, 2, 3, 4
	<NRf>	Position. Range depends on the vertical scale.
Return parameter	<NR3>	Returns the position value.
Example 1	:CHANnel1:POSition 2.4E-3 Sets the Channel 1 position to 2.4mV/mA	
Example 2	:CHANnel1:POSition? 2.4E-3 Returns 2.4mV as the vertical position.	

		(Set) →
		→ (Query)
:CHANnel<X>:PROBe:RATio		
Description	Sets or returns the probe attenuation factor.	
Syntax	:CHANnel<X>:PROBe:RATio { <NRf> ?}	
Related Commands	:CHANnel<X>:PROBe:TYPE	
Parameter	<X>	Channel 1, 2, 3, 4
	<NRf>	Probe attenuation factor
Return parameter	<NR3>	Returns the probe factor
Example	:CHANnel1:PROBe:RATio 1.00E+0 Sets the Channel 1 probe attenuation factor to 1x	

		(Set) →
		→ (Query)
:CHANnel<X>:PROBe:TYPE		
Description	Sets or returns the probe type (voltage/current).	
Syntax	:CHANnel<X>:PROBe:TYPE { VOLTage CURRent ?}	
Related Commands	:CHANnel<X>:PROBe:RATio	
Parameter	<X>	Channel 1, 2, 3, 4
	VOLTage	Voltage
	CURRent	Current
Return parameter	Returns the probe type.	
Example	:CHANnel1:PROBe:TYPE VOLTage Sets the Channel 1 probe type to voltage.	

		(Set) →
		→ (Query)
:CHANnel<X>:SCALE		
Description	Sets or returns the vertical scale. The scale depends on the probe attenuation factor. Note the probe attenuation factor should be set before the scale.	

Syntax	:CHANnel<X>:SCALE { <NRf> ?}	
Parameter	<X>	Channel 1, 2, 3, 4
	<NRf>	Vertical scale: 2e-3 to 1e+1 2mV to 10V (Probe x1)
Return parameter	<NR3>	Returns the vertical scale in volts or amps.
Example	:CHANnel1:SCALE 2.00E-2	
	Sets the Channel 1 vertical scale to 20mV/div	

Math Commands

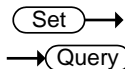

:MATH:DISP	56
:MATH:TYPe	57
:MATH:DUAL:SOURce<X>	57
:MATH:DUAL:OPERator	57
:MATH:DUAL:POSition	58
:MATH:DUAL:SCALe	58
:MATH:FFT:SOURce	59
:MATH:FFT:MAG	59
:MATH:FFT:WINDow	59
:MATH:FFT:POSition	60
:MATH:FFT:SCALe	60
:MATH:FFT:HORizontal:SCALe	61
MATH:FFT:HORizontal:POSition	61
:MATH:DEFine	61
MATHVAR?	62
MATHVAR:VAR<X>	63
:MATH:ADVanced:POSition	63
:MATH:ADVanced:SCALe	63

:MATH:DISP

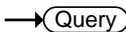

Description	Turns the math display on or off on the screen.	
Syntax	:MATH:DISP {OFF ON ?}	
Parameter/ Return parameter	OFF	Math is not displayed on screen
	ON	Math is displayed on screen
Example	:MATH:DISP OFF Math is off.	

		
		
<hr/>		
:MATH:TYPE		
Description	Queries or sets the Math type to FFT, Advanced Math or to dual channel math operations	
Syntax	:MATH:TYPE { DUAL ADVanced FFT ? }	
Related Commands	:MATH:DISP	
Parameter	DUAL	Dual channel operations
	ADVanced	Advanced math operations
	FFT	FFT operations
Return parameter	Returns the math type.	
Example	:MATH:TYPE DUAL Sets the Math type to dual channel math operation.	

		
		
<hr/>		
:MATH:DUAL:SOURce<X>		
Description	Sets the dual math source for source 1 or 2.	
Syntax	:MATH:DUAL:SOURce<X> { CH1 CH2 CH3 CH4 REF1 REF2 REF3 REF4 ? }	
Parameter	<X>	Source number 1 or 2
	CH1~4	Channel 1 to 4
	REF1~4	Reference waveforms 1 to 4
Return parameter	Returns the source for the source 1 or 2.	
Example	:MATH:DUAL:SOURce1 CH1 Sets source1 as channel 1.	

		
		
<hr/>		
:MATH:DUAL:OPERator		
Description	Sets the math operator for dual math operations.	

Syntax	:MATH:DUAL:OPERator {PLUS MINUS MUL DIV ?}	
Parameter	PLUS	+ operator
	MINUS	- operator
	MUL	× operator
	DIV	÷ operator
Return parameter	Returns operator type.	
Example	:MATH:DUAL:OPERator PLUS Sets the math operator as plus (+).	

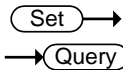

:MATH:DUAL:POSition

Description	Sets the vertical position of the displayed math result expressed by unit/division.	
Syntax	:MATH:DUAL:POSition {<NRf> ? }	
Parameter	<NRf>	Vertical position Depends on the vertical scale (Unit/Div)
Return parameter	<NR3>	Returns the vertical position.
Example	:MATH:DUAL:POSition 1.0E+0 Sets the vertical position to 1.00 unit/div.	

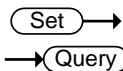

:MATH:DUAL:SCALe

Description	Sets the vertical scale of the displayed math result.	
Syntax	:MATH:DUAL:SCALe {<NRf> ? }	
Parameter	<NRf>	Vertical scale
Return parameter	<NR3>	Returns the scale.
Example	:MATH:DUAL:SCALe 2.0E-3 Sets the vertical scale to 2mV/2mA.	

:MATH:FFT:SOURce



Description	Sets and queries the FFT math source.	
Syntax	:MATH:FFT:SOURce { CH1 CH2 CH3 CH4 REF1 REF2 REF3 REF4 ? }	
Related commands	:MATH:ADVanced:EDIT:SOURce<X> :MATH:ADVanced:EDIT:OPERator	
Parameter	CH1~4	Channel 1 to 4
	REF1~4	Reference waveform 1 to 4
Return parameter	Returns the FFT source.	
Example	:MATH:FFT:SOURce CH1 Sets the FFT math source as channel 1.	

:MATH:FFT:MAG



Description	Sets FFT vertical units as linear or decibels.	
Syntax	:MATH:FFT:MAG {LINEAR DB ?}	
Parameter	LINEAR	Linear units (Vrms)
	DB	Logarithmic units (dB)
Return parameter	Returns the FFT vertical units.	
Example	:MATH:FFT:MAG DB Sets FFT vertical units to dB.	

:MATH:FFT:WINDow



Description	Sets the windowing filter used for the FFT function.	
Syntax	:MATH:FFT:WINDow {RECTangular HAMming HANning BLAckman ?}	
Parameter	RECTangular	Rectangular window

HAMming	Hamming window
HANning	Hanning window
BLAckman	Blackman window

Return parameter Returns the FFT window.

Example :MATH:FFT:WINDow HAMming
Sets the FFT window filter to hamming.

Set →

→ Query

:MATH:FFT:POSition

Description Sets the vertical position of the displayed FFT result.

Syntax MATH:FFT:POSition { <NRf> | ? }

Parameter <NRf> Vertical position: -12e+0 to +12e+0 (12 units/division to +12 units/division.)

Return parameter <NR3> Returns the vertical position.

Example :MATH:FFT:POSition -2e-1
Sets the FFT position to -0.2 divisions.

Set →

→ Query

:MATH:FFT:SCALE

Description Sets the vertical scale of the displayed FFT result.

Syntax :MATH:FFT:SCALE {<NRf> | ?}

Parameter <NRf> Vertical scale:
Linear: 2e-3 to 1e+3 (2mV~1kV)
dB: 1e+0 to 2e+1 (1~20dB)

Return parameter <NR3> Returns vertical scale.

Example :MATH:FFT:SCALE 1.0e+0
Sets the scale to 1dB.

Set →
 → Query

:MATH:FFT:HORizontal:SCALE

Description	Sets or queries the zoom scale for FFT math.	
Syntax	:MATH:FFT:HORizontal:SCALE {<NRf> ?}	
Parameter	<NRf>	Zoom scale: 1 to 20 times
Return parameter	<NR3>	Returns zoom scale.
Example	:MATH:FFT:HORizontal:SCALE 5 Sets the zoom scale to 5X.	

Set →
 → Query

MATH:FFT:HORizontal:POSition

Description	Sets the horizontal position of the displayed FFT result.	
Syntax	MATH:FFT:HORizontal:POSition { <NRf> ? }	
Parameter	<NRf>	Horizontal position: 0Hz ~ 999.9kHz
Return parameter	<NR3>	Returns the vertical position.
Example	:MATH:FFT:HORizontal:POSition 6.0e5 Sets the FFT horizontal position to 600kHz.	

Set →
 → Query

:MATH:DEFine

Description	Sets or queries the advanced math expression as a string.	
Syntax	:MATH:DEFine {<string> ?}	
Related	:MATH:DISP :MATH:TYPE	
Parameter	<string>	An expression enclosed in double quotes. Note, ensure parentheses are used correctly in the expression. The expression can contain the following parts:

Source	CH1~CH4, Ref1~Ref4
Function	Intg(, Diff(, log(, ln(, Exp(, Sqrt(, Abs(, Rad(, Deg(, sin(, cos(, tan(, asin(, acos(, atan(
Variable	VAR1, VAR2
Operator	+, -, *, /, (,), !(, <, >, <=, >=, ==, !=, , &&
Figure	0, 1, 2, 3, 4, 5, 6, 7, 8, 9, ., E
Measurement	Pk-Pk(, Max(, Min(, Amp(, High(, Low(, Mean(, CycleMean(, RMS(, CycleRMS(, Area(, CycleArea(, ROVShoot(, FOVShoot(, Freq(, Period(, Rise(, Fall(, PosWidth(, NegWidth(, Dutycycle(, FRR(, FRF(, FFR(, FFF(, LRR(, LRF(, LFR(, LFF(, Phase(

Return parameter Returns the expression as a string.

Example :MATH:DISP ON
 :MATH:TYPE ADVanced
 MATH:DEFine "CH1-CH2"
 Sets the math expression to CH1-CH2.

MATHVAR?



Description	Returns the value of the VAR1 and VAR2 variables.
Syntax	MATHVAR?
Related Commands	MATHVAR:VAR<X> MATH:DEFine
Return parameter	<string> VAR1 <NR3>; VAR2 <NR3>

Example MATHVAR?
 VAR1 1.000000E+06; VAR2 1.0E+1
 Returns the value of both variables.

Set →

→ Query

MATHVAR:VAR<X>

Description Sets or returns the VAR1 or VAR2 variables.

Syntax MATHVAR:VAR<x> {<NRf> | ?}

Related MATH:DEFine
 Commands

Parameter	<X>	1, 2 (VAR1 or VAR2)
	<NRf>	Value of VAR1/VAR2

Return parameter	<NR3>	Returns the value of VAR1/VAR2
------------------	-------	--------------------------------

Example :MATH:VAR1 6.0e4
 Sets VAR1 to 60000.

Set →

→ Query

:MATH:ADVanced:POSition

Description Sets the vertical position of the advanced math result, expressed in unit/div.

Syntax MATH:ADVanced:POSition { <NRf> | ? }

Parameter	<NRf>	Vertical position: -12e+0 to +12e+0 (12 units/division to +12 units/division.)
-----------	-------	--

Return parameter	<NR3>	Returns the vertical position.
------------------	-------	--------------------------------

Example :MATH:ADVanced:POSition 1.0e+0
 Sets the position as 1.00 unit/div.

Set →

→ Query

:MATH:ADVanced:SCALE

Description Sets or queries the vertical scale the advanced math result.

Syntax :MATH:ADVanced:SCALE {<NRf> | ?}

Parameter	<NRf>	Vertical scale
Return parameter	<NR3>	Returns the vertical scale.
Example	:MATH:ADVanced:SCALE 2.0E-3 Sets the vertical scale to 2mV/Div.	

Cursor Commands

:CURSor:MODE	66
:CURSor:SOURce.....	66
:CURSor:HUNI	67
:CURSor:HUSE	67
:CURSor:VUNI	68
:CURSor:VUSE	68
:CURSor:DDT	68
:CURSor:H1Position	69
:CURSor:H2Position	69
:CURSor:HDELta	70
:CURSor:V1Position.....	70
:CURSor:V2Position.....	70
:CURSor:VDELta	71
:CURSor:XY:RECTangular:X:POSition<X>	71
:CURSor:XY:RECTangular:X:DELta	71
:CURSor:XY:RECTangular:Y:POSition<X>	72
:CURSor:XY:RECTangular:Y:DELta	72
:CURSor:XY:POLar:RADIUS:POSition<X>.....	72
:CURSor:XY:POLar:RADIUS:DELta	73
:CURSor:XY:POLar:THETA:POSition<X>	73
:CURSor:XY:POLar:THETA:DELta	73
:CURSor:XY:PRODuct:POSition<X>	74
:CURSor:XY:PRODuct:DELta.....	74
:CURSor:XY:RATio:POSition<X>.....	74
:CURSor:XY:RATio:DELta	75

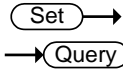

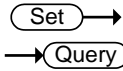

:CURSor:MODE

Description	Sets cursor mode to horizontal (H) or horizontal and vertical (HV). Note: When the cursor source is set to bus, then only the horizontal cursor is available.	
Syntax	:CURSor:MODE {OFF H HV ? }	
Parameter	OFF	Turns the cursors off.
	H	Turns the horizontal cursors on.
	HV	Turns horizontal and vertical cursors on.
Return parameter	Returns the state of the cursors (H, HV, OFF).	
Example	:CURSor:MODE OFF Turns the cursors off.	



:CURSor:SOURce

Description	Sets or queries the cursor source.	
Syntax	:CURSor:SOURce {CH1 CH2 CH3 CH4 REF1 REF2 REF3 REF4 MATH LOGic BUS1 ? }	
Parameter	CH1~CH4	Channel 1 to 4
	REF1~4	Reference waveform 1 to 4
	MATH	Math source
	LOGic	Logic source
	BUS1	Bus source
Return parameter	Returns the cursor source.	
Example	:CURSor:SOURce CH1 Turns the cursor source as channel 1.	

 									
:CURSor:HUNI									
Description	Sets or queries the units for the horizontal bar cursors.								
Syntax	:CURSor:HUNI {SEConds HERTz DEGrees PERcent ?}								
Related Commands	:CURSor:MODe								
Parameter	<table border="0"> <tr> <td>SEConds</td> <td>Sets the cursor units to time in seconds.</td> </tr> <tr> <td>HERtz</td> <td>Sets the cursor units to frequency.</td> </tr> <tr> <td>DEGrees</td> <td>Sets the cursor units to degrees.</td> </tr> <tr> <td>PERcent</td> <td>Sets the cursor units to percent.</td> </tr> </table>	SEConds	Sets the cursor units to time in seconds.	HERtz	Sets the cursor units to frequency.	DEGrees	Sets the cursor units to degrees.	PERcent	Sets the cursor units to percent.
SEConds	Sets the cursor units to time in seconds.								
HERtz	Sets the cursor units to frequency.								
DEGrees	Sets the cursor units to degrees.								
PERcent	Sets the cursor units to percent.								
Return parameter	Returns the unit type.								
Example	:CURSor:HUNI SEConds Sets the units to time in seconds.								

	
:CURSor:HUSE	
Description	Sets the current cursor position as the phase or ratio reference for the Percent or Degrees (horizontal) cursors.
Note	This command can only be used when :CURSor:HUNI is set to DEGrees or PERcent.
Syntax	:CURSor:HUSE {CURRent}
Related Commands	:CURSor:MODe :CURSor:HUNI
Parameter	CURRent Uses the current horizontal position
Example	:CURSor:HUSE CURRent.

Set →
 → Query

:CURSor:VUNI

Description	Sets or queries the units for the vertical bar cursors.	
Syntax	:CURSor:VUNI {BASE PERcent ?}	
Related Commands	:CURSor:MODE	
Parameter	BASE	Sets the vertical cursor units the same as the scope units (V or A).
	PERcent	Sets the displayed units to percent.
Return parameter	Returns the unit type.	
Example	:CURSor:VUNI BASE Sets the units to the base units.	

Set →

:CURSor:VUSE

Description	Sets the current cursor position as the ratio reference for the Percent (vertical) cursors.	
Note	This command can only be used when :CURSor:VUNI is set to PERcent.	
Syntax	:CURSor:VUSE {CURRent}	
Related Commands	:CURSor:MODE :CURSor:VUNI	
Parameter	CURRent	Uses the current vertical position
Example	:CURSor:VUSE CURRent.	

→ Query

:CURSor:DDT

Description	Returns the deltaY/deltaT (dy/dT) readout. This function is only supported if the source channels are CH1~4, Ref1~4 or Math.	
Syntax	:CURSor:DDT{?}	

Related Commands :CURSor:MODE

Return Parameter <NR3> Returns the readout in <NR3> format.

Example :CURSor:DDT?
4.00E-05

Set →

→ Query

:CURSor:H1Position

Description Sets or returns the first horizontal cursor (H1) position.

Syntax :CURSor:H1Position {<NRf> | ?}

Related Commands :CURSor:H2Position

Parameter <NRf> Horizontal position

Return parameter Returns the cursor position.

Example :CURSor:H1Position?
-1.34E-3

Returns the H1 cursor position as -1.34ms.

Set →

→ Query

:CURSor:H2Position

Description Sets or returns the second horizontal cursor (H2) position.

Syntax :CURSor:H2Position {<NRf> | ?}

Related Commands :CURSor:H1Position

Parameter <NRf> Horizontal Position

Return parameter Returns the cursor position.

Example :CURSor:H2Position 1.5E-3

Sets the H2 cursor position to 1.5ms.

:CURSor:HDELta

→ Query

Description	Returns the delta of H1 and H2.
Syntax	:CURSor:HDELta{?}
Return Parameter	<NR3> Returns the distance between two horizontal cursors.
Example	:CURSor:HDELta? 5.0E-9 Returns the horizontal delta as 5ns.

:CURSor:V1Position

Set →

→ Query

Description	Sets the first vertical cursor (V1) position.
Syntax	:CURSor:V1Position {<NRf> ?}
Parameter	<NRf> Vertical position. Depends on the vertical scale.
Return parameter	<NR3> Returns the cursor position.
Example	:CURSor:V1Position 1.6E -1 Sets the V1 cursor position to 160mA.

Set →

:CURSor:V2Position

→ Query

Description	Sets the first vertical cursor (V2) position.
Syntax	:CURSor:V2Position {<NRf> ?}
Parameter	<NRf> Vertical position. Depends on the vertical scale.
Return parameter	<NR3> Returns the cursor position.
Example	:CURSor:V2Position 1.1E-1 Sets the V2 cursor position to 110mA.

:CURSor:VDELta → Query

Description	Returns the delta of V1 and V2.	
Syntax	:CURSor:VDELta{?}	
Return Parameter	<NR3>	Returns the difference between two vertical cursors.
Example	:CURSor:VDELta? 4.00E+0 Returns the vertical delta as 4 volts.	

:CURSor:XY:RECTangular:X:POSition<X> Set →
→ Query

Description	Sets or queries the horizontal position in XY mode for the X rectangular coordinates for cursor 1 or 2.	
Syntax	:CURSor:XY:RECTangular:X:POSition<X> {<NRf> ?}	
Parameter	<X>	Cursor 1, 2
	<NRf>	Horizontal position co-ordinates
Return parameter	<NR3>	Returns the cursor position.
Example	:CURSor:XY:RECTangular:X:POSition1 4.0E-3 Sets the X-coordinate cursor 1 position to 40mV/mV.	

:CURSor:XY:RECTangular:X:DELta → Query

Description	Returns the delta value of cursor 1 and 2 on the X coordinate.	
Syntax	:CURSor:XY:RECTangular:X:DELta{?}	
Return Parameter	<NR3>	Returns the delta value of cursor 1 and 2 as <NR3>.

Example :CURSOR:XY:RECTangular:X:DELta?
80.0E-3
Returns the horizontal delta as 80mV.

Set →

:CURSOR:XY:RECTangular:Y:POSition<X> → Query

Description Sets or queries the vertical position in XY mode for the Y rectangular coordinates for cursor 1 or 2.

Syntax :CURSOR:XY:RECTangular:Y:POSition<X> {<NRf>|?}

Parameter <X> Cursor 1, 2
<NRf> Vertical position co-ordinates

Return parameter <NR3> Returns the cursor position.

Example :CURSOR:XY:RECTangular:Y:POSition1 4.0E-3
Sets the Y-coordinate cursor 1 position to 40mV/mV.

:CURSOR:XY:RECTangular:Y:DELta → Query

Description Returns the delta value of cursor 1 and 2 on the Y coordinate.

Syntax :CURSOR:XY:RECTangular:Y:DELta{?}

Return Parameter <NR3> Returns the delta value of cursor 1 and 2 as <NR3>.

Example :CURSOR:XY:RECTangular:Y:DELta?
80.0E-3
Returns the horizontal delta as 80mV.

:CURSOR:XY:POLar:RADIUS:POSition<X> → Query

Description Queries the polar radius position for the specified cursor in XY mode, where X can be either cursor 1 or 2.

Syntax	:CURSor:XY:POLar:RADIUS:POSition<X>{?}
Parameter	<X> 1, 2 (cursor 1, cursor 2)
Return Parameter	<NR3> Returns the polar radius position.
Example	:CURSor:XY:POLar:RADIUS:POSition1? 80.0E-3 Returns the polar radius position as 80.0mV.

:CURSor:XY:POLar:RADIUS:DELta → Query

Description	Returns the radius delta value of cursor 1 and 2.
Syntax	:CURSor:XY:POLar:RADIUS:DELta{?}
Return Parameter	<NR3> Returns the radius delta.
Example	:CURSor:XY:POLar:RADIUS:DELta? 31.4E-3 Returns the radius delta as 31.4mV.

:CURSor:XY:POLar:THETA:POSITION<X> → Query

Description	Queries the polar angle for the specified cursor in XY mode, where X can be either 1 or 2.
Syntax	:CURSor:XY:POLar:THETA:POSITION<X>{?}
Parameter	<X> 1, 2 (Cursor 1, Cursor 2)
Return parameter	<NR3> Returns the polar angle.
Example	:CURSor:XY:POLar:RADIUS:POSition1? 8.91E+1 Returns the polar angle for cursor1 as 89.1°.

:CURSor:XY:POLar:THETA:DELta → Query

Description	Queries the polar angle delta between cursor1 and cursor2.
-------------	--

Syntax	:CURSor:XY:POLar:THETA:DELta{?}	
Return parameter	<NR3>	Returns the theta delta between cursor1 and cursor2.
Example	:CURSor:XY:POLar:THETA:DELta? 9.10E+0 Returns the delta as 9.1°.	

:CURSor:XY:PRODUct:POSItion<X> → Query

Description	Queries the product in XY mode for the specified cursor, where x can be either 1 or 2.	
Syntax	:CURSor:XY:PRODUct:POSItion<X>{?}	
Parameter	<X>	1, 2 (Cursor 1, Cursor 2)
Return parameter	<NR3>	Returns the product value of the Cursor1 or Cursor2.
Example	:CURSor:XY:PRODUct:POSItion1? 9.44E-5 Returns the product of cursor1 as 94.4uVV.	

:CURSor:XY:PRODUct:DELta → Query

Description	Queries the product delta in XY mode.	
Syntax	:CURSor:XY:PRODUct:DELta{?}	
Return parameter	<NR3>	Returns the product delta.
Example	:CURSor:XY:PRODUct:DELta? 1.22E-5 Returns the product delta as 12.2uVV.	

:CURSor:XY:RATio:POSItion<X> → Query

Description	Queries the ratio in XY mode for the specified cursor, where x can be either cursor 1 or 2.	
-------------	---	--

Syntax	:CURSor:XY:RATio:POSition<X>{?}
Parameter	<X> 1, 2 (Cursor 1, Cursor 2)
Return parameter	<NR3> Returns the ratio.
Example	:CURSor:XY:RATio:POSition? 6.717E+1 Returns the ratio value as 6.717V/V.

:CURSor:XY:RATio:DELta → Query

Description	Queries the ratio delta in XY mode.
Syntax	:CURSor:XY:RATio:DELta{?}
Return parameter	<NR3> Returns the ratio delta.
Example	:CURSor:XY:RATio:DELta? 5.39E+1 Returns the ratio delta as 53.9V/V.

Display Commands

:DISPlay:INTensity:WAVEform.....	75
:DISPlay:INTensity:GRATICule.....	76
:DISPlay:INTensity:BACKLight	76
:DISPlay:INTensity:BACKLight:AUTODim:ENABLE	76
:DISPlay:INTENSITY:BACKLight:AUTODim:TIME	77
:DISPlay:PERSiStence	77
:DISPlay:GRATICule	78
:DISPlay:WAVEform.....	78
:DISPlay:OUTPut	78

:DISPlay:INTensity:WAVEform Set →
→ Query

Description	Sets or queries the waveform intensity level.
-------------	---

Syntax	:DISPlay:INTensity:WAVEform {<NRf> ?}
Parameter	<NRf> 0.0E+0 to 1.0E+2 (0% to 100%)
Return Parameter	<NR3> Returns the intensity.
Example	:DISPlay:INTensity:WAVEform 5.0E+1 Sets the waveform intensity to 50%.

Set →

→ Query

:DISPlay:INTensity:GRATicule

Description	Sets or queries the graticule intensity level.
Syntax	:DISPlay:INTensity:GRATicule {<NRf> ?}
Parameter	<NRf> 1.0E+0 to 1.0E+2 (10% to 100%)
Return Parameter	<NR3> Returns the graticule intensity.
Example	:DISPlay:INTensity:GRATicule 5.0E+1 Sets the graticule intensity to 50%.

Set →

→ Query

:DISPlay:INTensity:BACKLight

Description	Sets or queries the intensity of the backlight display.
Syntax	:DISPlay:INTensity:BACKLight {<NRf> ?}
Parameter	<NRf> 1.0E+0 to 1.0E+2 (10% to 100%)
Return Parameter	<NR3> Returns the backlight intensity.
Example	:DISPlay:INTensity:BACKLight 5.0E+1 Sets the backlight intensity to 50%.

Set →

→ Query

**:DISPlay:INTensity:BACKLight:AUTODim
:ENABLE**

Description	Sets or queries the display auto-dim function.
Syntax	:DISPlay:INTensity:BACKLight:AUTODim:ENABLE {OFF ON ?}

Parameter/	OFF	Turn auto-dim on.
Return parameter	ON	Turn auto-dim off.

Example :DISPlay:INTensity:BACKLight:AUTODim:ENABLE ON
Turns the auto-dim function on.

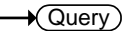
:DISPlay:INTENSITY:BACKLight:AUTODim 
:TIME 

Description Sets or queries the display auto-dim time.

Syntax :DISPlay:INTensity:BACKLight:AUTODim:TIME
{ <NR1> | ? }

Parameter/	<NR1>	1 ~ 180 minutes. Time in minutes.
Return parameter		

Example :DISPlay:INTensity:BACKLight:AUTODim:TIME 10
Sets the auto-dim time to 10 minutes.

:DISPlay:PERSistence 

Description Sets or queries the waveform persistence level.

Syntax :DISPlay:PERSistence { INFInite | OFF | <NRf> | ? }





Parameter	<NRf>	1.6E-2 ~ 4.0E+0. (16mS to 10S) Range(1.6E-2, 30E-3, 60E-3, 120E-2, 240E-3, 500E-3, 750E-3, 1, 1.5,2,...,9.5,10
	INFInite	Infinite persistence
	OFF	No persistence

Return Parameter	<NR3>	Returns the persistence time.
	INFInite	Infinite persistence
	OFF	No persistence

Example :DISPlay:PERSistence 2.0E+0
Sets the persistence to 2 seconds.

:DISPlay:GRATicule

Set →
→ Query

Description	Sets or queries graticule display type.			
Syntax	:DISPlay:GRATicule {FULL GRID CROSSs FRAMe ?}			
Parameter	FULL		CROSSs	
	FRAMe		GRID	

Return parameter Returns the graticule type.

Example :DISPlay:GRATicule FULL
Sets the graticule to .

Set →
→ Query

:DISPlay:WAVEform

Description Sets or queries whether the waveforms are drawn as vectors or dots.

Syntax :DISPlay:WAVEform {VECTor | DOT | ?}

Parameter	VECTor	Vectors
	DOT	Dots

Return parameter Returns VECTOR or DOT.

Example :DISPlay:WAVEform VECTor
Sets the waveform to vectors.

:DISPlay:OUTPut

→ Query

Description Returns the screen image as a 16 bit RGB run length encoded image.

Syntax :DISPlay:OUTPut{?}

Return parameter Format: header+data+LF

For example assuming the image data size is 60072 bytes then the following would be returned:

#560072<[count] [color] [count] [color]..... ><LF>

Where #560072 is the header, each [count] and [color] data are 2 bytes and <LF> is a line feed character.

Hardcopy Commands

:HARDcopy:START	79
:HARDcopy:MODE	79
:HARDcopy:PRINTINKSaver	80
:HARDcopy:SAVEINKSaver	80
:HARDcopy:SAVEFORMat	81
:HARDcopy:ASSIGN	81

:HARDcopy:START



Description	Executing the HARDcopy:START command is the equivalent of pressing the Hardcopy key on the front panel.
Syntax	:HARDcopy:START
Related Commands	:HARDcopy:MODE :HARDcopy:PRINTINKSaver :HARDcopy:SAVEINKSaver :HARDcopy:SAVEFORMat :HARDcopy:ASSIGN

:HARDcopy:MODE

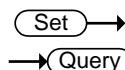

Description	Sets or queries whether hardcopy is set to print or save.
Syntax	:HARDcopy:MODE { PRINT SAVE ? }

Related Commands :HARDcopy:START

Parameter	PRINT	Print mode
	SAVE	Save mode

Return parameter Returns the mode.(PRINT/SAVE)

Example :HARDcopy:MODE PRINT
Sets hardcopy to print.

Set →

→ Query

:HARDcopy:PRINTINKSaver

Description Sets Inksaver On or Off for printing.

Syntax :HARDcopy:PRINTINKSaver { OFF | ON | ? }

Related Commands :HARDcopy:START
:HARDcopy:MODE

Parameter	ON	Inksaver ON
	OFF	Inksaver OFF

Return parameter Returns the print Ink Saver mode.(ON/OFF)

Example :HARDcopy:PRINTINKSaver ON
Sets Ink Saver to ON for printing.

Set →

→ Query

:HARDcopy:SAVEINKSaver

Description Sets Inksaver On or Off for saving screen images.

Syntax :HARDcopy:SAVEINKSaver { OFF | ON | ? }

Related Commands :HARDcopy:START
:HARDcopy:MODE

Parameter	ON	Inksaver ON
	OFF	Inksaver OFF

Return parameter Returns the screen image Ink Saver mode (ON/OFF).

Example :HARDcopy:SAVEINKSaver ON
Sets Inksaver to ON for saving screen images.

:HARDcopy:SAVEFORMat



Description	Sets or queries the image save file type.				
Syntax	:HARDcopy:SAVEFORMat { PNG BMP ? }				
Related Commands	:HARDcopy:START :HARDcopy:MODE				
Parameter	<table border="0"> <tr> <td style="background-color: #cccccc;">PNG</td> <td>PNG file format</td> </tr> <tr> <td style="background-color: #cccccc;">BMP</td> <td>BMP file format</td> </tr> </table>	PNG	PNG file format	BMP	BMP file format
PNG	PNG file format				
BMP	BMP file format				
Return parameter	Returns the image file format (PNG/BMP).				
Example	:HARDcopy:SAVEFORMat PNG Sets the file format to PNG.				

:HARDcopy:ASSIGN



Description	Sets or queries what file type the hardcopy key has been assigned to save.								
Syntax	:HARDcopy:ASSIGN {IMAGe WAVEform SETUp ALL ?}								
Related Commands	:HARDcopy:START :HARDcopy:MODE								
Parameter	<table border="0"> <tr> <td style="background-color: #cccccc;">IMAGe</td> <td>Save image files.</td> </tr> <tr> <td style="background-color: #cccccc;">WAVEform</td> <td>Save waveforms.</td> </tr> <tr> <td style="background-color: #cccccc;">SETUp</td> <td>Save the panel setup.</td> </tr> <tr> <td style="background-color: #cccccc;">ALL</td> <td>Save All (image, waveform,setup)</td> </tr> </table>	IMAGe	Save image files.	WAVEform	Save waveforms.	SETUp	Save the panel setup.	ALL	Save All (image, waveform,setup)
IMAGe	Save image files.								
WAVEform	Save waveforms.								
SETUp	Save the panel setup.								
ALL	Save All (image, waveform,setup)								
Return parameter	Returns the file type. (IMAGE/WAVEFORM/SETUP/ALL)								
Example	:HARDcopy:ASSIGN IMAGE. Set the hardcopy key to save image files.								

Measure Commands

:MEASure:GATing.....	83
:MEASure:SOURce	83
:MEASure:METHod	84
:MEASUrement:REFLevel:PERCent:HIGH	84
:MEASUrement:REFLevel:PERCent:LOW	85
:MEASUrement:REFLevel:PERCent:MID	85
:MEASUrement:REFLevel:PERCent:MID2	85
:MEASure:FALL.....	86
:MEASure:FOVShoot.....	86
:MEASure:FPreshoot	87
:MEASure:FREQuency.....	87
:MEASure:NWIDth	88
:MEASure:PDUTy	88
:MEASure:PERiod	89
:MEASure:PWIDth	89
:MEASure:RISe	90
:MEASure:ROVShoot.....	90
:MEASure:RPreshoot.....	91
:MEASure:PPULSE.....	92
:MEASure:NPULSE.....	92
:MEASure:PEDGE	93
:MEASure:NEDGE	93
:MEASure:AMPlitude.....	94
:MEASure:MEAN	94
:MEASure:CMEan	95
:MEASure:HIGH	96
:MEASure:LOW.....	96
:MEASure:MAX.....	97
:MEASure:MIN	97
:MEASure:PK2PK.....	98
:MEASure:RMS	98
:MEASure:CRMS.....	99

:MEASure:AREa	100
:MEASure:CARea	100
:MEASure:FRRDelay	101
:MEASure:FRFDelay.....	101
:MEASure:FFRDelay.....	102
:MEASure:FFFDelay.....	103
:MEASure:LRRDelay	103
:MEASure:LRFDelay.....	104
:MEASure:LFRDelay.....	104
:MEASure:LFFDelay.....	105
:MEASure:PHAsE.....	106

:MEASure:GATing

Set →

→ Query

Description	Sets or queries the measurement gating.	
Syntax	:MEASure:GATing { OFF SCREEn CURSor ? }	
Parameter	OFF	Full record
	SCREEn	Gating set to screen width
	CURSor	Gating between cursors
Return parameter	Returns the gating. (OFF, SCREEN, CURSOR)	
Example	:MEASure:GATing OFF Turns gating off (full record).	

:MEASure:SOURce

Set →

→ Query

Description	Sets or queries the measurement source for source1 or source2.	
Syntax	:MEASure:SOURce<X> { CH1 CH2 CH3 CH4 MATH ? }	
Parameter	<X>	Source1 or source2
	CH1~CH4	Channel 1 to 4

MATH Math

Return parameter Returns the source (CH1, CH2, CH3, CH4, MATH)

Example :MEASure:SOURce1 CH1
Sets source1 to channel 1.

:MEASure:METHOD

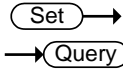

Description Sets or queries the method used to determine the High-Low measurement values.

Syntax :MEASure:METHOD { AUTO | HISTogram | MINMax | ? }

Parameter	AUTO	Set to auto.
	HISTogram	Set to the Histogram method.
	MINMax	Set to the Min-Max method.

Return parameter Returns the measurement method (AUTO, HISTOGRAM, MINMAX)

Example :MEASure:METHOD: AUTO
Set the measurement method to auto.

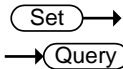

:MEASUrement:REFLevel:PERCent:HIGH

Description Sets or queries the high reference level as a percentage.

Syntax :MEASUrement:REFLevel:PERCent:HIGH {<NRF> | ?}

Parameter	<NRF>	0 - 100%
-----------	-------	----------

Return parameter Returns the high reference level

Example :MEASUrement:REFLevel:PERCent:HIGH 50.1
Set the high reference level to 50.1%.

:MEASUrement:REFLevel:PERCent:LOW



Description	Sets or queries the low reference level as a percentage.
Syntax	:MEASUrement:REFLevel:PERCent:LOW {<NRf> ?}
Parameter	<NRf> 0 - 100%
Return parameter	Returns the low reference level.
Example	:MEASUrement:REFLevel:PERCent:LOW 40.1 Set the low reference level to 40.1%.

:MEASUrement:REFLevel:PERCent:MID



Description	Sets or queries the first mid reference level as a percentage.
Syntax	:MEASUrement:REFLevel:PERCent:MID {<NRf> ?}
Parameter	<NRf> 0 - 100%
Return parameter	Returns the mid reference level.
Example	:MEASUrement:REFLevel:PERCent:MID 50 Set the mid reference level to 50%.

:MEASUrement:REFLevel:PERCent:MID2



Description	Sets or queries the second mid reference level as a percentage.
Syntax	:MEASUrement:REFLevel:PERCent:MID2 {<NRf> ?}
Parameter	<NRf> 0 - 100%
Return parameter	Returns the mid reference level of the second source.
Example	:MEASUrement:REFLevel:PERCent:MID2 50 Set the mid reference level to 50%.

:MEASure:FALL

→ **Query**

Description	Returns the fall time measurement result.	
Syntax	:MEASure:FALL{?}	
Related Commands	:MEASure:SOURce<X>	
Return parameter	<NR3>	
	Chan Off	Indicates the source channel is not activated.
Note	Before using this command, select the measurement channel. See the example below.	
Example	:MEASure:SOURce1 CH1 :MEASure:FALL? Selects Channel 1 as the source, and then measures the fall time.	

:MEASure:FOVShoot

→ **Query**

Description	Returns the fall overshoot amplitude.	
Syntax	:MEASure:FOVShoot{?}	
Related Commands	:MEASure:SOURce<X>	
Return parameter	<NR3>	Returns the fall overshoot as a percentage
	Chan Off	Indicates the source channel is not activated.
Note	Before using this command, select the measurement channel. See the example below.	

Example :MEASure:SOURce1 CH1
 :MEASure:FOVShoot?
 1.27E+0
 Selects Channel 1, and then measures the fall overshoot.

:MEASure:FPReshoot → Query

Description Returns fall preshoot amplitude.

Syntax :MEASure:FPReshoot{?}

Related Commands :MEASure:SOURce<X>

Returns Returns the fall preshoot as <NR3>.

Return parameter	<NR3>	Returns the fall preshoot as a percentage.
	Chan Off	Indicates the source channel is not activated.

Note Before using this command, select the measurement channel. See the example below.

Example :MEASure:SOURce1 CH1
 :MEASure:FPReshoot?
 Selects Channel 1, and then measures the fall preshoot.

:MEASure:FREQuency → Query

Description Returns the frequency value.

Syntax :MEASure:FREQuency{?}

Related Commands :MEASure:SOURce<X>

Return parameter	<NR3>	Returns the frequency in Hz.
	Chan Off	Indicates the source channel is not activated.

Note Before using this command, select the measurement channel. See the example below.

Example :MEASure:SOURce1 CH1
 :MEASure:FREQuency?
 >1.0E+3
 Selects Channel 1, and then measures the frequency.

:MEASure:NWIDth → Query

Description Returns the first negative pulse width timing.

Syntax :MEASure:NWIDth{?}

Related Commands :MEASure:SOURce<X>

Return parameter	<NR3>	Returns the negative pulse width in seconds.
	Chan Off	Indicates the source channel is not activated.

Note Before using this command, select the measurement channel. See the example below.

Example :MEASure:SOURce1 CH1
 :MEASure:NWIDth?
 4.995E-04
 Selects Channel 1, and then measures the negative pulse width.

:MEASure:PDUTy → Query

Description Returns the positive duty cycle ratio as percentage.

Syntax :MEASure:PDUTy{?}

Related commands :MEASure:SOURce<X>

Return parameter	<NR3>	Returns the positive duty ratio.
------------------	--------------------	----------------------------------

Chan Off	Indicates the source channel is not activated.
----------	--

Note Before using this command, select the measurement channel. See the example below.

Example :MEASure:SOURce1 CH1
 :MEASure:PDUTy?
 5.000E+01
 Selects Channel 1, and then measures the positive duty cycle.

:MEASure:PERiod → Query

Description Returns the period.

Syntax :MEASure:PERiod{?}

Related Commands :MEASure:SOURce<X>

Return parameter <NR3>	Returns the period.
Chan Off	Indicates the source channel is not activated.

Note Before using this command, select the measurement channel. See the example below.

Example :MEASure:SOURce1 CH1
 :MEASure:PERiod?
 1.0E-3
 Selects Channel 1, and then measures the period.

:MEASure:PWIDth → Query

Description Returns the first positive pulse width.

Syntax :MEASure:PWIDth{?}

Related Commands :MEASure:SOURce<X>

Return parameter	<NR3>	Returns the positive pulse width.
	Chan Off	Indicates the source channel is not activated.
Note	Before using this command, select the measurement channel. See the example below.	
Example	<pre>:MEASure:SOURce1 CH1 :MEASure:PWIDth? 5.0E-6</pre> Selects Channel 1, and then measures the positive pulse width.	

:MEASure:RISe → Query

Description	Returns the first pulse rise time.	
Syntax	:MEASure:RISe{?}	
Related Commands	:MEASure:SOURce<X>	
Return parameter	<NR3>	Returns the rise time.
	Chan Off	Indicates the source channel is not activated.
Note	Before using this command, select the measurement channel. See the example below.	
Example	<pre>:MEASure:SOURce1 CH1 :MEASure:RISe? 8.5E-6</pre> Selects Channel 1, and then measures the rise time.	

:MEASure:ROVShoot → Query

Description	Returns the rising overshoot over the entire waveform in percentage.	
Syntax	:MEASure:ROVShoot{?}	

Related Commands	:MEASure:SOURce<X>	
Return parameter	<NR3>	Returns the overshoot.
	Chan Off	Indicates the source channel is not activated.
Note	Before using this command, select the measurement channel. See the example below.	
Example	:MEASure:SOURce1 CH1 :MEASure:ROVShoot? 5.00E+00 Selects Channel 1, and then measures the rise overshoot.	

:MEASure:RPReshoot → Query

Description	Returns rising preshoot over the entire waveform in percentage.	
Syntax	:MEASure:RPReshoot{?}	
Related Commands	:MEASure:SOURce<X>	
Return parameter	<NR3>	Returns the rising preshoot.
	Chan Off	Indicates the source channel is not activated.
Note	Before using this command, select the measurement channel. See the example below.	
Example	:MEASure:SOURce1 CH1 :MEASure:RPReshoot? 2.13E-2 Selects Channel 1, and then measures the rise preshoot.	

:MEASure:PPULSE

→ **Query**

Description	Returns the number of positive pulses.	
Syntax	:MEASure:PPULSE{?}	
Related Commands	:MEASure:SOURce<X>	
Return parameter	<NR3>	Returns the number of positive pulses.
	Chan Off	Indicates the source channel is not activated.
Note	Before using this command, select the measurement channel. See the example below.	
Example	:MEASure:SOURce1 CH1	
	:MEASure:PPULSE?	
	6.000E+00	
	Selects Channel 1, and then measures the number of positive pulses.	

:MEASure:NPULSE

→ **Query**

Description	Returns the number of negative pulses.	
Syntax	:MEASure:NPULSE{?}	
Related Commands	:MEASure:SOURce<X>	
Return parameter	<NR3>	Returns the number of negative pulses.
	Chan Off	Indicates the source channel is not activated.

Note Before using this command, select the measurement channel. See the example below.

Example :MEASure:SOURce1 CH1
 :MEASure:NPULSE?
 4.000E+00
 Selects Channel 1, and then measures the number of negative pulses.

:MEASure:PEDGE → Query

Description Returns the number of positive edges.

Syntax :MEASure:PEDGE{?}

Related Commands :MEASure:SOURce<X>

Return parameter	<NR3>	Returns the number of positive edges.
	Chan Off	Indicates the source channel is not activated.

Note Before using this command, select the measurement channel. See the example below.

Example :MEASure:SOURce1 CH1
 :MEASure:PEDGE?
 1.100E+01
 Selects Channel 1, and then measures the number of positive edges.

:MEASure:NEDGE → Query

Description Returns the number of negative edges.

Syntax :MEASure:NEDGE{?}

Related Commands :MEASure:SOURce<X>

Return parameter	<NR3>	Returns the number of negative edges.
------------------	--------------------	---------------------------------------

Chan Off	Indicates the source channel is not activated.
----------	--

Note Before using this command, select the measurement channel. See the example below.

Example :MEASure:SOURce1 CH1
 :MEASure:NEDGE?
 1.100E+01
 Selects Channel 1, and then measures the number of negative edges.

:MEASure:AMplitude → Query

Description Returns the amplitude difference between the Vhigh-Vlow.

Syntax :MEASure:AMplitude{?}

Related Commands :MEASure:SOURce<X>

Return parameter <NR3>	Returns the amplitude.
Chan Off	Indicates the source channel is not activated.

Note Before using this command, select the measurement channel. See the example below.

Example :MEASure:SOURce1 CH1
 :MEASure:AMplitude?
 3.76E-3
 Selects Channel 1, and then measures the amplitude.

:MEASure:MEAN → Query

Description Returns the mean voltage/current of one or more full periods.

Syntax :MEASure:MEAN{?}

Related Commands	:MEASure:SOURce<X>	
Return parameter	<NR3>	Returns the mean.
	Chan Off	Indicates the source channel is not activated.
Note	Before using this command, select the measurement channel. See the example below.	
Example	:MEASure:SOURce1 CH1 :MEASure:MEAN? 1.82E-3 Selects Channel 1, and then measures the mean value.	

:MEASure:CMEan → Query

Description	Returns the mean voltage/current of one full period.	
Syntax	:MEASure:CMEan{?}	
Related Commands	:MEASure:SOURce<X>	
Return parameter	<NR3>	Returns the cyclic mean.
	Chan Off	Indicates the source channel is not activated.
Note	Before using this command, select the measurement channel. See the example below.	
Example	:MEASure:SOURce1 CH1 :MEASure:CMEan? 9.480E-01 Selects Channel 1, and then measures the mean value of the first period.	

:MEASure:HIGH

→ Query

Description	Returns the global high voltage/current.	
Syntax	:MEASure:HIGH{?}	
Related Commands	:MEASure:SOURce<X>	
Return parameter	<NR3>	Returns the high value.
	Chan Off	Indicates the source channel is not activated.
Note	Before using this command, select the measurement channel. See the example below.	
Example	:MEASure:SOURce1 CH1	
	:MEASure:HIGH?	
	3.68E-3	
	Selects Channel 1, and then measures the high voltage/current.	

:MEASure:LOW

→ Query

Description	Returns the global low voltage/current.	
Syntax	:MEASure:LOW{?}	
Related Commands	:MEASure:SOURce<X>	
Return parameter	<NR3>	Returns the global low value.
	Chan Off	Indicates the source channel is not activated.
Note	Before using this command, select the measurement channel. See the example below.	

Example :MEASure:SOURce1 CH1
 :MEASure:LOW?
 1.00E-0
 Selects Channel 1, and then measures the low current/voltage.

:MEASure:MAX → Query

Description Returns the maximum amplitude.

Syntax :MEASure:MAX{?}

Related Commands :MEASure:SOURce<X>

Return parameter	<NR3>	Returns the maximum amplitude.
	Chan Off	Indicates the source channel is not activated.

Note Before using this command, select the measurement channel. See the example below.

Example :MEASure:SOURce1 CH1
 :MEASure:MAX?
 1.90E-3
 Selects Channel 1, and then measures the maximum amplitude.

:MEASure:MIN → Query

Description Returns the minimum amplitude.

Syntax :MEASure:MIN{?}

Related Commands :MEASure:SOURce<X>

Return parameter	<NR3>	Returns the minimum amplitude.
	Chan Off	Indicates the source channel is not activated.

Note Before using this command, select the measurement channel. See the example below.

Example :MEASure:SOURce1 CH1
 :MEASure:MIN?
 -8.00E-3
 Selects Channel 1, and then measures the minimum amplitude.

:MEASure:PK2PK → Query

Description Returns the peak-to-peak amplitude (difference between maximum and minimum amplitude).

Syntax :MEASure:PK2Pk{?}

Related Commands :MEASure:SOURce<X>

Return parameter	<NR3>	Returns the voltage or current peak to peak measurement.
	Chan Off	Indicates the source channel is not activated.

Note Before using this command, select the measurement channel. See the example below.

Example :MEASure:SOURce1 CH1
 :MEASure:PK2Pk?
 2.04E-1
 Selects Channel 1, and then measures the peak-to-peak amplitude.

:MEASure:RMS → Query

Description Returns the root-mean-square voltage/current of one or more full periods.

Syntax :MEASure:RMS{?}

Related Commands	:MEASure:SOURce<X>	
Return parameter	<NR3>	Returns the RMS value.
	Chan Off	Indicates the source channel is not activated.
Note	Before using this command, select the measurement channel. See the example below.	
Example	:MEASure:SOURce1 CH1 :MEASure:RMS? 1.31E-3 Selects Channel 1, and then measures the RMS voltage/current.	

:MEASure:CRMS → Query

Description	Returns the root-mean-square voltage/current of one full periods.	
Syntax	:MEASure:CRMS{?}	
Related Commands	:MEASure:SOURce<X>	
Return parameter	<NR3>	Returns the CRMS value.
	Chan Off	Indicates the source channel is not activated.
Note	Before using this command, select the measurement channel. See the example below.	
Example	:MEASure:SOURce1 CH1 :MEASure:CRMS? 1.31E-3 Selects Channel 1, and then measures the CRMS voltage/current.	

:MEASure:AREa

→ **Query**

Description	Returns the voltage/current area over one or more full periods.	
Syntax	:MEASure:AREa{?}	
Related Commands	:MEASure:SOURce<X>	
Return parameter	<NR3>	Returns the area value.
	Chan Off	Indicates the source channel is not activated.
Note	Before using this command, select the measurement channel. See the example below.	
Example	:MEASure:SOURce1 CH1 :MEASure:AREa? 1.958E-03 Selects Channel 1, and then measures the area.	

:MEASure:CARea

→ **Query**

Description	Returns the voltage/current area over one full period.	
Syntax	:MEASure:CARea{?}	
Related Commands	:MEASure:SOURce<X>	
Return parameter	<NR3>	Returns the area value.
	Chan Off	Indicates the source channel is not activated.
Note	Before using this command, select the measurement channel. See the example below.	

Example :MEASure:SOURce1 CH1
 :MEASure:CARea?
 1.958E-03
 Selects Channel 1, and then measures the area.

:MEASure:FRRDelay → Query

Description Returns the delay between the first rising edge of source1 and the first rising edge of source2.

Syntax :MEASure:FRRDelay{?}

Related Commands :MEASure:SOURce<X>

Return parameter	<NR3>	Returns the delay.
	Chan Off	Indicates the source channel is not activated.

Note Select the two source channels before entering this command.

Example :MEASure:SOURce1 CH1
 :MEASure:SOURce2 CH2
 :MEASure:FRRDelay?
 -4.68E-6
 Select channel 1 and 2 as source1/2, and then measure FRR.

:MEASure:FRFDelay → Query

Description Returns the delay between the first rising edge of source1 and the first falling edge of source2.

Syntax :MEASure:FRFDelay{?}

Related Commands :MEASure:SOURce<X>

Return parameter	<NR3>	Returns the delay.
------------------	--------------------	--------------------

Chan Off	Indicates the source channel is not activated.
----------	--

Note Select the two source channels before entering this command.

Example :MEASure:SOURce1 CH1
 :MEASure:SOURce2 CH2
 :MEASure:FRFDelay?
 3.43E-6
 Select channel 1 and 2 as source1/2, and then measures FRF.

:MEASure:FFRDelay → Query

Description Returns the delay between the first falling edge of source1 and the first rising edge of source2.

Syntax :MEASure:FRRDelay{?}

Related Commands :MEASure:SOURce<X>

Return parameter <NR3> Returns the delay.

Chan Off	Indicates the source channel is not activated.
----------	--

Note Select the two source channels before entering this command.

Example :MEASure:SOURce1 CH1
 :MEASure:SOURce2 CH2
 :MEASure:FRRDelay?
 -8.56E-6
 Select channel 1 and 2 as delay source1/2, and then measure FFR.

:MEASure:FFFDelay → Query

Description Returns the delay between the first falling edge of source1 and the first falling edge of source2.

Syntax :MEASure:FFFDelay{?}

Related Commands :MEASure:SOURce<X>

Return parameter	<NR3>	Returns the delay.
	Chan Off	Indicates the source channel is not activated.

Note Select the two source channels before entering this command.

Example

```
:MEASure:SOURce1 CH1
:MEASure:SOURce2 CH2
:MEASure:FFFDelay?
-8.89E-6
```

Select channel 1 and 2 as delay source1/2, and then measure FFF.

:MEASure:LRRDelay → Query

Description Returns the delay between the first rising edge of source1 and the last rising edge of source2.

Syntax :MEASure:LRRDelay{?}

Related Commands :MEASure:SOURce<X>

Return parameter	<NR3>	Returns the delay.
	Chan Off	Indicates the source channel is not activated.

Note Select the two source channels before entering this command.

Example :MEASure:SOURce1 CH1
 :MEASure:SOURce2 CH2
 :MEASure:LRRDelay?
 -8.89E-6
 Select channel 1 and 2 as delay source1/2, and then measure LRR.

:MEASure:LRFDelay → Query

Description Returns the delay between the first rising edge of source1 and the last rising edge of source2.

Syntax :MEASure:LRFDelay{?}

Related Commands :MEASure:SOURce<X>

Return parameter	<NR3>	Returns the delay.
	Chan Off	Indicates the source channel is not activated.

Note Select the two source channels before entering this command.

Example :MEASure:SOURce1 CH1
 :MEASure:SOURce2 CH2
 :MEASure:LRFDelay?
 -4.99E-6
 Select channel 1 and 2 as delay source1/2, and then measure LRF.

:MEASure:LFRDelay → Query

Description Returns the delay between the first falling edge of source1 and the last rising edge of source2.

Syntax :MEASure:LFRDelay{?}

Related Commands :MEASure:SOURce<X>

Return parameter	<NR3>	Returns the delay.
	Chan Off	Indicates the source channel is not activated.
Note	Select the two source channels before entering this command.	
Example	<pre>:MEASure:SOURce1 CH1 :MEASure:SOURce2 CH2 :MEASure:LFRDelay? -9.99E-6</pre> <p>Select channel 1 and 2 as delay source1/2, and then measure LFR.</p>	

:MEASure:LFFDelay → Query

Description	Returns the delay between the first falling edge of source1 and the last falling edge of source2.	
Syntax	:MEASure:LFFDelay{?}	
Related Commands	:MEASure:SOURce<X>	
Return parameter	<NR3>	Returns the delay.
	Chan Off	Indicates the source channel is not activated.
Note	Select the two source channels before entering this command.	
Example	<pre>:MEASure:SOURce1 CH1 :MEASure:SOURce2 CH2 :MEASure:LFFDelay? -9.99E-6</pre> <p>Select channel 1 and 2 as delay source1/2, and then measure LFF.</p>	

:MEASure:PHase

→ **Query**

Description	Returns the phase between source 1 and source 2.	
Syntax	:MEASure:PHase{?}	
Related Commands	:MEASure:SOURce<X>	
Return parameter	<NR3>	Returns the phase difference.
	Chan Off	Indicates the source channel is not activated.
Note	Select the two source channels before entering this command.	
Example	<pre>:MEASure:SOURce1 CH1 :MEASure:SOURce2 CH2 :MEASure:PHase? 4.50E+01</pre> <p>Select channel 1 and 2 as phase source1/2, and then measure the phase in degrees.</p>	

Measurement Commands

:MEASUrement:MEAS<X>:SOURCE<X>	107
:MEASUrement:MEAS<X>:TYPE	108
:MEASUrement:MEAS<X>:STATE	108
:MEASUrement:MEAS<X>:VALue	109
:MEASUrement:MEAS<X>:MAXimum	110
:MEASUrement:MEAS<X>:MEAN	111
:MEASUrement:MEAS<X>:MINimum	111
:MEASUrement:MEAS<X>:STDdev	112
:MEASUrement:STATIstics:MODE	113
:MEASUrement:STATIstics:WEIghting	113
:MEASUrement:STATIstics	113

:MEASUrement:MEAS<X>:SOURCE<X>  

Description	Sets or queries the measurement source for a selected automatic measurement. This is a statistics related command.	
Syntax	:MEASUrement:MEAS<X>:SOURCE<X> { CH1 CH2 CH3 CH4 MATH D0 D1 D2 D3 D4 D5 D6 D7 D8 D9 D10 D11 D12 D13 D14 D15 ? }	
Related commands	:MEASUrement:MEAS<X>:TYPE	
Parameter	MEAS<X>	The automatic measurement number from 1 to 8.
	SOURCE<X>	SOURCE1: the source for all single channel measurements.
	SOURCE<X>	SOURCE2: the source for all delay or phase measurements.
	CH1 to CH4	Channel 1, 2, 3, 4
	MATH	Math source
	D0~D15	Digital source D0~D15

Return parameter	CH1 to CH4	Channel 1, 2, 3, 4
	MATH	Math source

Example :MEASUrement:MEAS1:SOURCE1?
>CH1
Returns the (first) source for measurement 1.

:MEASUrement:MEAS<X>:TYPE Set →
→ Query

Description Sets or queries the measurement type for a selected automatic measurement. This is a statistics related command.

Syntax :MEASUrement:MEAS<X>:TYPE
 {PK2pk | MAXimum | MINIMUM | AMPLitude | HIGH | LOW | MEAN | CMEan | RMS | CRM s | AREa | CARea | ROVShoot | FOVShoot | RPReshoot | FPReshoot | FREQuency | PERIod | RISE | FALL | PWIdth | NWIdth | PDUTy | PPULSE | NPULSE | PEDGE | NEDGE | FRRDelay | FRFDelay | FFRDelay | FFFDelay | LRRDelay | LRFDelay | LFRDelay | LFFDelay | PHAse | ?}

Related commands :MEASUrement:MEAS<X>:SOURCE<X>

Parameter	MEAS<X>	The automatic measurement number from 1 to 8.
-----------	---------	---

Return parameter Returns the measurement type

Example :MEASUrement:MEAS1:TYPE RMS
Sets measurement 1 to RMS measurement.

:MEASUrement:MEAS<X>:STATE Set →
→ Query

Description Sets or queries the state of a selected measurement. This is a statistics related command.

Syntax :MEASUrement:MEAS<X>:STATE { ON | OFF | 1 | 0 | ? }

Related commands	:MEASUrement:MEAS<X>:SOURce<X> :MEASUrement:MEAS<X>:TYPE	
Parameter	MEAS<X>	The automatic measurement number from 1 to 8.
	ON/1	Turn the measurement on.
	OFF/0	Turn the measurement off.
Return parameter	0	Measurement is off.
	1	Measurement is on.
Example	:MEASUrement:MEAS1:STATE 1 Turns measurement 1 on.	

:MEASUrement:MEAS<X>:VALue → Query

Description	Returns the measurement results for the selected measurement. This is a statistics related command.	
Syntax	:MEASUrement:MEAS<X>:VALue?	
Related Commands	:MEASure:SOURce<X>	
Parameter	MEAS<X>	The automatic measurement number from 1 to 8.
Return parameter	<NR3>	Returns the measurement for the selected measurement number.
Note	The measurement source(s), measurement number, measurement type and measurement state must first be set before a measurement result can be returned.	

Example :MEASUrement:MEAS1:SOUrce1 CH1
 :MEASUrement:MEAS1:TYPe PK2PK
 :MEASUrement:MEAS1:STATE ON
 :MEASUrement:MEAS1:VALue?
 5.000E+0

Selects channel 1 as the source for measurement 1, sets measurement 1 to peak to peak measurement and then turns on the measurement. The result returns the peak to peak measurement.

:MEASUrement:MEAS<X>:MAXimum → **Query**

Description Returns the maximum measurement results for the selected measurement from the last time the statistics were reset. This is a statistics related command.

Syntax :MEASUrement:MEAS<X>:MAXimum?

Related Commands :MEASUrement:STATIstics:MODE

Parameter	MEAS<X>	The automatic measurement number from 1 to 8.
-----------	---------	---

Return parameter	<NR3>	Returns the measurement for the selected measurement number.
------------------	-------	--

Example :MEASUrement:MEAS3:SOUrce1 CH1
 :MEASUrement:MEAS3:TYPe PK2PK
 :MEASUrement:MEAS3:STATE ON
 :MEASUrement:STATIstics:MODE ON
 :MEASUrement:MEAS3:MAXimum?
 2.800E-02

Returns the maximum measurement result for measurement number 3.

:MEASUrement:MEAS<X>:MEAN → Query

Description Returns the mean measurement results for the selected measurement from the last time the statistics were reset. This is a statistics related command.

Syntax :MEASUrement:MEAS<X>:MEAN?

Related Commands :MEASUrement:STATIstics:MODE

Parameter	MEAS<X>	The automatic measurement number from 1 to 8.
------------------	---------	---

Return parameter	<NR3>	Returns the measurement for the selected measurement number.
-------------------------	-------	--

Example

```
:MEASUrement:MEAS3:SOUrce1 CH1
:MEASUrement:MEAS3:TYPe PK2PK
:MEASUrement:MEAS3:STATE ON
:MEASUrement:STATIstics:MODE ON
:MEASUrement:MEAS3:MEAN?
2.090E-02
```

Returns the mean measurement result for measurement number 3.

:MEASUrement:MEAS<X>:MINIum → Query

Description Returns the minimum measurement results for the selected measurement from the last time the statistics were reset. This is a statistics related command.

Syntax :MEASUrement:MEAS<X>:MINIum?

Related Commands :MEASUrement:STATIstics:MODE

Parameter	MEAS<X>	The automatic measurement number from 1 to 8.
------------------	---------	---

Return parameter	<NR3>	Returns the measurement for the selected measurement number.
------------------	-------	--

Example

```
:MEASUrement:MEAS3:SOUrce1 CH1
:MEASUrement:MEAS3:TYPe PK2PK
:MEASUrement:MEAS3:STATE ON
:MEASUrement:STATIstics:MODE ON
:MEASUrement:MEAS3:MINIumum?
1.600E-02
```

Returns the minimum measurement result for measurement number 3.

:MEASUrement:MEAS<X>:STDdev → Query

Description

Returns the standard deviation for the selected measurement from the last time the statistics were reset. This is a statistics related command.

Syntax

```
:MEASUrement:MEAS<X>:STDdev?
```

Related Commands

```
:MEASUrement:STATIstics:MODE
```

Parameter	MEAS<X>	The automatic measurement number from 1 to 8.
-----------	---------	---

Return parameter	<NR3>	Returns the measurement for the selected measurement number.
------------------	-------	--

Example

```
:MEASUrement:MEAS3:SOUrce1 CH1
:MEASUrement:MEAS3:TYPe PK2PK
:MEASUrement:MEAS3:STATE ON
:MEASUrement:STATIstics:MODE ON
:MEASUrement:MEAS3:STDdev?
1.530E-03
```

Returns the standard deviation for measurement number 3.

:MEASUREMENT:STATISTICS:MODE (Set) →
→ (Query)

Description	Puts the statics measurement results on the display or queries whether the statistics are displayed.	
Syntax	:MEASUREMENT:STATISTICS:MODE {OFF ON ?}	
Related commands	:MEASUREMENT:STATISTICS	
Parameter/ Return parameter	ON	Display the statistics on the screen.
	OFF	Remove the statistics from the screen
Example	:MEASUREMENT:STATISTICS:MODE ON Displays statistics on the screen.	

:MEASUREMENT:STATISTICS:WEIGHTING (Set) →
→ (Query)

Description	Sets and queries the number of samples (weighting) used for the statistics calculations.	
Syntax	:MEASUREMENT:STATISTICS:WEIGHTING { <NR1> ? }	
Parameter/ Return parameter	<NR1>	Number of samples (2~1000)
Example	:MEASUREMENT:STATISTICS:WEIGHTING 5 Sets the number of samples to 5.	

:MEASUREMENT:STATISTICS (Set) →

Description	Resets the statics calculations. This command will clear all the currently accumulated measurements.
Syntax	:MEASUREMENT:STATISTICS {RESET}

Reference Commands

:REF<X>:DISPlay	114
:REF<X>:TIMebase:POSition	114
:REF<X>:TIMebase:SCALe	115
:REF<X>:OFFSet	115
:REF<x>:SCALe	116

:REF<X>:DISPlay



Description Sets or queries whether a reference waveform will be shown on the display. A reference waveform must first be saved before this command can be used.

Syntax :REF<x>:DISPlay { OFF| ON| ? }

Parameter	<X>	Reference waveform 1, 2, 3, 4.
	OFF	Turns the selected reference waveform off
	ON	Turns the selected reference waveform on

Return parameter Returns the status of the selected reference waveform. (OFF, ON).

Example :REF1:DISPlay ON
Turns on reference1 (REF 1) on the display.

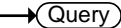
:REF<X>:TIMebase:POSition



Description Sets or returns the selected reference waveform time base position.

Syntax :REF<X>:TIMebase:POSition { <NRF> | ? }

Related commands :REF<X>:DISPlay

Parameter	<X>	Reference waveform 1, 2, 3, 4.
	<NRf>	Horizontal co-ordinates
Return parameter	<NR3>	Returns the reference waveform position
Example	:REF1:TIMEbase:POSition -5.000E-5 Selects reference 1, and then sets the horizontal position to -50us.	

:REF<X>:TIMEbase:SCALE (Set) →
→ (Query)

Description	Sets or returns the selected reference waveform time base scale.	
Syntax	:REF<X>:TIMEbase:SCALE { <NRf> ?}	
Related commands	:REF<X>:DISPlay	
Parameter	<X>	Reference waveform 1, 2, 3, 4.
	<NRf>	Horizontal scale
Return parameter	<NR3>	Returns the reference waveform scale.
Example	:REF1:TIMEbase:SCALE 5.00E-4 Selects reference 1, and then sets the horizontal scale to 500us/div.	

:REF<X>:OFFSet (Set) →
→ (Query)

Description	Sets or returns the selected reference waveform vertical position (offset).	
Syntax	:REF<X>:OFFSet { <NRf> ?}	
Related commands	:REF<X>:DISPlay	
Parameter	<X>	Reference waveform 1, 2, 3, 4.
	<NRf>	Vertical offset

Return parameter <NR3> Returns the reference waveform vertical position.

Example :REF1:OFFSet -5.000E-2
 Selects reference 1, and then sets the vertical position to -50mV/mA.

:REF<x>:SCALE

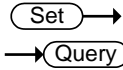

Description Sets or returns the selected reference waveform vertical scale.

Syntax :REF<X>:SCALE { <NRf> | ? }

Related commands :REF<X>:DISPlay

Parameter <X> Reference waveform 1, 2, 3, 4.
 <NRf> Vertical scale

Return parameter <NR3> Returns the reference waveform vertical scale.

Example :REF1:SCALE 5.000E-2
 Selects reference 1, and then sets the vertical scale to 50mV | mA/div.

Run Command

:RUN



Description	The run command allows the oscilloscope to continuously make acquisitions (equivalent to pressing the Run key on the front panel).
-------------	--

Syntax	:RUN
--------	------

Stop Command

:STOP



Description	The stop command stops the oscilloscope making further acquisitions (equivalent to pressing the Stop key on the front panel).
-------------	---

Syntax	:STOP
--------	-------

Single Command

:SINGle



Description	The single command allows the oscilloscope to capture a single acquisition when trigger conditions have been fulfilled (equivalent to pressing the Single key on the front panel).
-------------	--

Syntax	:SINGle
--------	---------

Force Command

:FORCe



Description	The Force command forces an acquisition (equivalent to pressing the Force-Trig key on the front panel).
-------------	---

Syntax	:FORCe
--------	--------

Timebase Commands

:TIMebase:EXPand	119
:TIMebase:POSition	119
:TIMebase:SCALe.....	119
:TIMebase:MODE	120
:TIMebase:WINDow:POSition	120
:TIMebase:WINDow:SCALe	121

:TIMebase:EXPand

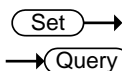

Description Sets or queries the horizontal expansion mode.

Syntax :TIMebase:EXPand {CENTer|TRIGger|?}

Parameter/Return parameter	CENTer	Expand from the center of the display.
	TRIGger	Expand from the trigger point.

Example :TIMebase:EXPand TRIGger
Sets the expansion point to the trigger point.

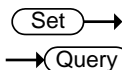

:TIMebase:POSition

Description Sets or queries the horizontal position.

Syntax :TIMebase:POSition {<NRf> | ?}

Parameter	<NRf>	Horizontal position
Return parameter	<NR3>	Returns the horizontal position

Example :TIMebase:POSition 5.00E-4
Sets the horizontal position as 500us.

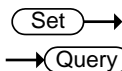

:TIMebase:SCALe

Description Sets or queries the horizontal scale.

Syntax	:TIMebase:SCALe {<NRf> ?}	
Parameter	<NRf>	Horizontal scale
Return parameter	<NR3>	Returns the horizontal scale.
Example	:TIMebase:SCALe 5.00E-2 Sets the horizontal scale to 50ms/div.	

Set →

:TIMebase:MODE

→ Query

Description	Sets or queries the time base mode. The time base mode determines the display view window on the scope.	
Syntax	:TIMebase:MODE {MAIN WINDow XY ?}	
Parameter	MAIN	Sets the time base mode to the main screen.
	WINDow	Sets the time base mode to the zoom window.
	XY	Sets the time base mode to the XY display.
Return parameter	Returns the time base mode (MAIN, WINDOW, XY)	
Example	:TIMebase:MODE MAIN Sets the time base mode to the main mode.	

Set →

:TIMebase:WINDow:POSition

→ Query

Description	Sets or queries the zoom horizontal position.	
Syntax	:TIMebase:WINDow:POSition {<NRf> ?}	
Related commands	:TIMebase:MODE	
Parameter	<NRf>	Horizontal position for zoom window
Return parameter	<NR3>	Returns the zoom horizontal position.

Example :TIMebase:WINDow:POSition 2.0E-3
 Sets the zoom horizontal position as 20ms.

:TIMebase:WINDow:SCALE 

Description	Sets or queries the zoom horizontal scale.	
Note	If the oscilloscope is under “ZOOM” mode, the main timebase function will be disabled and cannot be modified.	
Syntax	:TIMebase:WINDow:SCALE {<NRf> ?}	
Related commands	:TIMebase:MODE	
Parameter	<NRf>	Zoom horizontal scale. The range will depend on the time base.
Return parameter	<NR3>	Returns the zoom horizontal scale.
Example	:TIMebase:WINDow:SCALE 2.0E-3 Sets the zoom horizontal scale to 2ms.	

Trigger Commands

:TRIGger:FREQuency.....	124
:TRIGger:TYPe	124
:TRIGger:SOURce	125
:TRIGger:COUPle.....	125
:TRIGger:NREJ	126
:TRIGger:MODe.....	126
:TRIGger:HOLDoff.....	126
:TRIGger:LEVel.....	127
:TRIGger:HLEVel	127
:TRIGger:LLEVel.....	128
:TRIGger:EDGe:SLOP.....	128
:TRIGger:DElay:SLOP	128
:TRIGger:DElay:TYPe.....	129
:TRIGger:DElay:TIMe.....	129
:TRIGger:DElay:EVENT.....	130
:TRIGger:DElay:LEVel	130
:TRIGger:PULSEWidth:POLarity	130
:TRIGger:RUNT:POLarity	131
:TRIGger:RUNT:WHEn.....	131
:TRIGger:RUNT:TIMe.....	132
:TRIGger:RISEFall:SLOP.....	132
:TRIGger:RISEFall:WHEn	132
:TRIGger:RISEFall:TIMe	133
:TRIGger:VIDeo:TYPe	134
:TRIGger:VIDeo:FIELD	134
:TRIGger:VIDeo:LINE	135
:TRIGger:VIDeo:POLarity	135
:TRIGger:PULSe:WHEn	135
:TRIGger:PULSe:TIMe	136
:TRIGger:TIMEOut:WHEn.....	136
:TRIGger:TIMEOut:TIMER	137
:TRIGger:ALTErnate	137

:TRIGger:STATe	138
:TRIGger:EXTERnal:PROBe:TYPe	138
:TRIGger:EXTERnal:PROBe:RATio	139
:TRIGger:BUS:TYPe	139
:TRIGger:BUS:THReshold:CH<x>	140
:TRIGger:BUS:B1:I2C:CONDition	140
:TRIGger:BUS:B1:I2C:ADDRes:MODE	141
:TRIGger:BUS:B1:I2C:ADDRes:TYPe	141
:TRIGger:BUS:B1:I2C:ADDRes:VALue	142
:TRIGger:BUS:B1:I2C:ADDRes:DIRection	142
:TRIGger:BUS:B1:I2C:DATA:SIZE	143
:TRIGger:BUS:B1:I2C:DATA:VALue	143
:TRIGger:BUS:B1:UART:CONDition	144
:TRIGger:BUS:B1:UART:RX:DATA:SIZE	145
:TRIGger:BUS:B1:UART:RX:DATA:VALue	145
:TRIGger:BUS:B1:UART:TX:DATA:SIZE	146
:TRIGger:BUS:B1:UART:TX:DATA:VALue	146
:TRIGger:BUS:B1:SPI:CONDition	147
:TRIGger:BUS:B1:SPI:DATA:SIZE	148
:TRIGger:BUS:B1:SPI:DATA:MISO:VALue	148
:TRIGger:BUS:B1:SPI:DATA:MOSI:VALue	149
:TRIGger:BUS:B1:CAN:CONDition	150
:TRIGger:BUS:B1:CAN:FRAMeType	150
:TRIGger:BUS:B1:CAN:IDentifier:MODE	151
:TRIGger:BUS:B1:CAN:IDentifier:VALue	151
:TRIGger:BUS:B1:CAN:IDentifier:DIRection	152
:TRIGger:BUS:B1:CAN:DATA:QUALifier	152
:TRIGger:BUS:B1:CAN:DATA:SIZE	153
:TRIGger:BUS:B1:CAN:DATA:VALue	154
:TRIGger:BUS:B1:LIN:CONDition	154
:TRIGger:BUS:B1:LIN:DATA:QUALifier	155
:TRIGger:BUS:B1:LIN:DATA:SIZE	156
:TRIGger:BUS:B1:LIN:DATA:VALue	156
:TRIGger:BUS:B1:LIN:ERRTYPe	157
:TRIGger:BUS:B1:LIN:IDentifier:VALue	158

:TRIGger:LOGic:INPut:CLOCK:SOURce..... 158
 :TRIGger:LOGic:INPut:CLOCK:EDGe..... 159
 :TRIGger:LOGic:FUNcTion 159
 :TRIGger:LOGic:PATtern 160
 :TRIGger:LOGic:PATtern:INPut:D<x> 160
 :TRIGger:LOGic:PATtern:DELtAtime..... 161
 :TRIGger:LOGic:PATtern:WHEn 161

:TRIGger:FREQUency → Query

Description	Queries the trigger frequency.
Syntax	:TRIGger:FREQUency{?}
Return parameter	<NR3> Returns the trigger frequency.
Example	:TRIGger:FREQUency? 1.032E+3 Returns the trigger frequency.

Set →

:TRIGger:TYPE → Query

Description	Sets or queries the trigger type.
Syntax	:TRIGger:TYPE {EDGE DELay PULSEwidth VIDeo RUNT RISEFall LOGic BUS TIMEOut ? }
Parameter	EDGE Edge trigger DELay Delay trigger PULSEwidth Pulse width trigger VIDeo Video trigger RUNT Runt trigger RISEFall Rise and fall trigger LOGic Logic trigger BUS Bus trigger

TIMEOut Timeout trigger

Return parameter Returns the trigger type.

Example :TRIGger:TYPe EDGE
Sets the trigger type to edge.

Set →

→ Query

:TRIGger:SOURce

Description Sets or queries the trigger source.

Syntax :TRIGger:SOURce
{ CH1 | CH2 | CH3 | CH4 | EXT | LINe | D0 | D1 | D2 | D3 | D4 | D5 | D6 | D7 | D8 | D9 | D10 | D11 | D12 | D13 | D14 | D15 | ? }

Parameter	CH1 to CH4	Channel 1 to channel 4
	EXT	External source
	LINe	AC Line
	D0~D15	Digital channels D0~D15

Return parameter Returns the trigger source.

Example :TRIGger:SOURce CH1
Sets the trigger source to channel 1.

Set →

→ Query

:TRIGger:COUPlE

Description Sets or queries the trigger coupling.

Note Applicable for edge and delay triggers only.

Syntax :TRIGger:COUPlE {AC | DC | HF | LF | ?}

Parameter	AC	AC mode
	DC	DC mode
	HF	High frequency rejection
	LF	Low frequency rejection

Return parameter Returns the trigger coupling.

Example :TRIGger:COUPle AC
Sets the trigger coupling to AC.

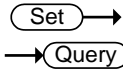

:TRIGger:NREJ

Description	Sets or queries noise rejection status.	
Syntax	:TRIGger:NREJ {OFF ON ?}	
Parameter	OFF	Turns noise rejection off
	ON	Turns noise rejection on

Return parameter Returns the noise rejection status (ON, OFF).

Example :TRIGger:NREJ ON
Turns noise rejection on.

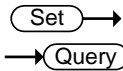

:TRIGger:MODE

Description	Sets or queries the trigger mode.	
Syntax	:TRIGger:MODE {AUTo NORMAl ?}	
Parameter	AUTo	Auto trigger (Untriggered roll)
	NORMAl	Normal trigger

Return parameter Returns the trigger mode.

Example :TRIGger:MODE NORMAl
Sets the trigger mode to normal.

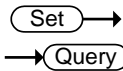

:TRIGger:HOLDoff

Description	Sets or queries the holdoff time.	
Syntax	:TRIGger:HOLDoff {<NRf> ?}	
Parameter	<NRf>	Holdoff time
Return parameter	<NR3>	Returns the trigger holdoff time.

Example :TRIGger:HOLDoff 1.00E-8
Sets the trigger holdoff time to 10ns.

:TRIGger:LEVel

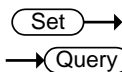

Description Sets or queries the level.

Note Not applicable to Pulse Runt and Rise & Fall triggers.

Syntax :TRIGger:LEVel {TTL | ECL | SETTO50 | <NRf> | ?}

Related commands :TRIGger:TYPE

Parameter	<NRf>	Trigger level value.
	TTL	Sets the trigger level to TTL.
	ECL	Sets the trigger level to ECL.
	SETTO50	Sets the trigger level to the User level (50% by default).

Return parameter <NR3> Returns the trigger level.

Example1 :TRIGger:LEVel TTL
Sets the trigger to TTL.

Example2 :TRIGger:LEVel 3.30E-1
Sets the trigger level to 330mV/mA.

:TRIGger:HLEVel

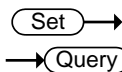

Description Sets or queries the high trigger level.

Note Applicable for Rise and Fall/Pulse Runt triggers.

Syntax :TRIGger:HLEVel {<NRf> | ?}

Related commands :TRIGger:TYPE

Parameter	<NRf>	High level value.
Return parameter	<NR3>	Returns the trigger high level.

Example :TRIGger:HLEVel 3.30E-1
 Sets the trigger high level to 330mV/mA.

Set →

:TRIGger:LLEVel

→ Query

Description Sets or queries the low trigger level.

Note Applicable for Rise and Fall/Pulse Runt triggers.

Syntax :TRIGger:LLEVel {<NRf> | ?}

Related commands :TRIGger:TYPe

Parameter	<NRf>	Low level value.
Return parameter	<NR3>	Returns the trigger low level.

Example :TRIGger:LLEVel -3.30E-3
 Sets the trigger low level to -330mV/mA.

Set →

:TRIGger:EDGE:SLOP

→ Query

Description Sets or queries the trigger slope.

Syntax :TRIGger:EDGE:SLOP {RISe | FALL | EITHer | ?}

Related commands :TRIGger:TYPe

Parameter	RISe	Rising slope
	FALL	Falling slope
	EITHer	Either rising or falling slope

Return parameter Returns the trigger slope.

Example :TRIGger:EDGE:SLOP FALL
 Sets the trigger slope to falling.

Set →

:TRIGger:DELaY:SLOP

→ Query

Description Sets or queries the trigger slope for the delay trigger.

Syntax :TRIGger:DElay:SLOP {RISe | FALL | EITHer | ? }

Related commands :TRIGger:TYPE

Parameter	RISe	Rising slope
	FALL	Falling slope
	EITHer	Either rising or falling slope

Return parameter Returns the trigger slope.

Example :TRIGger:DElay:SLOP FALL
Sets the trigger slope to falling.

:TRIGger:DElay:TYPE

Set →

→ Query

Description Sets or queries the trigger delay type.

Syntax :TRIGger:DElay:TYPE {TIME | EVENT | ? }

Related commands :TRIGger:TYPE

Parameter	TIME	Sets the delay type to time.
	EVENT	Sets the delay type to event.

Return parameter Returns the trigger delay type.

Example :TRIGger:DElay:TYPE TIME
Sets the delay type to time delay.

:TRIGger:DElay:TIME

Set →

→ Query

Description Sets or queries the delay time value.

Syntax :TRIGger:DElay:TIME {<NRf> | ? }

Related commands :TRIGger:DElay:TYPE

Parameter	<NRf>	Delay time (1.00E-8~1.00E+1)
-----------	-------	------------------------------

Return parameter <NR3> Returns the delay time.

Example :TRIGger:DElay:TIME 1.00E-6
Sets the delay time to 1us.

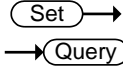

:TRIGger:DElay:EVENT

Description Sets or queries the number of events for the event delay trigger.

Syntax :TRIGger:DElay:EVENT {<NR1> | ?}

Related commands :TRIGger:DElay:TYPE

Parameter <NR1> 1~65535 events

Return parameter <NR1> Returns the number of events.

Example :TRIGger:DElay:EVENT 2
Sets the number of events to 2.

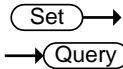

:TRIGger:DElay:LEVel

Description Sets or queries the trigger delay level.

Syntax :TRIGger:DElay:LEVel {<NRf> | ?}

Parameter <NRf> Delay trigger level

Return parameter <NR3> Returns the delay trigger.

Example :TRIGger:DElay:LEVel 5.00E-3
Sets the delay trigger level to 5mV/mA.

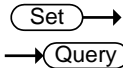

:TRIGger:PULSEWidth:POLarity

Description Sets or queries the pulse width trigger polarity.

Syntax :TRIGger:PULSEWidth:POLarity
{POSitive | NEGative | ?}

Related commands :TRIGger:TYPe

Parameter	POSitive	Positive polarity
	NEGative	Negative polarity

Return parameter Returns the pulse width polarity.

Example :TRIGger:PULSEWidth:POLarity POSitive
Sets the pulse width polarity to positive.

Set →

→ Query

:TRIGger:RUNT:POLarity

Description Sets or queries the Pulse Runt trigger polarity.

Syntax :TRIGger:RUNT:POLarity { POSitive | NEGative | EITher | ? }

Related commands :TRIGger:TYPe

Parameter	POSitive	Positive polarity
	NEGative	Negative polarity
	EITher	Positive or negative polarity

Return parameter Returns the pulse runt trigger polarity.

Example :TRIGger:RUNT:POLarity POSitive
Sets the Pulse Runt trigger polarity to positive.

Set →

→ Query

:TRIGger:RUNT:WHEn

Description Sets or queries the Pulse Runt trigger conditions.

Syntax :TRIGger:RUNT:WHEn { MOREthan | LESSthan | Equal | UNEQual | ? }

Related commands :TRIGger:TYPe
:TRIGger:RUNT:TIME

Parameter	MOREthan	>
	LESSthan	<

Equal =
 UNEQual ≠

Return parameter Returns the pulse runt trigger condition.

Example :TRIGger:RUNT:WHEn UNEQual
 Sets the Pulse Runt trigger condition to unequal (≠).

Set →
 → Query

:TRIGger:RUNT:TIME

Description Sets or queries the Pulse Runt trigger time.

Syntax :TRIGger:RUNT:TIME {<NRf> | ? }

Related commands :TRIGger:TYPe
 :TRIGger:RUNT:WHEn

Parameter <NRf> Pulse runt time (4nS to 10S)

Return Parameter <NR3> Returns the runt time in seconds.

Example :TRIGger:RUNT:TIME 4.00E-5
 Sets the runt time to 40.0uS.

Set →
 → Query

:TRIGger:RISEFall:SLOP

Description Sets or queries the Rise & Fall slope.

Syntax :TRIGger:RISEFall:SLOP {RISe | FALL | EITHer | ? }

Parameter RISe Rising slope
 FALL Falling slope
 EITHer Either rising or falling slope

Return parameter Returns the rise & fall slope.

Example :TRIGger:RISEFall:SLOP RISe
 Sets the Rise & Fall slope to rising.

Set →
 → Query

:TRIGger:RISEFall:WHEn

Description	Sets or queries the rise/fall trigger conditions.
Syntax	:TRIGger:RISEFall:WHEn {MOREthan LESSthan EQual UNEQual ? }
Related commands	:TRIGger:TYPE :TRIGger:RISEFall:TIME
Parameter	MOREthan > LESSthan < Equal = UNEQual ≠
Return parameter	Returns the rise/fall trigger condition.
Example	:TRIGger:RISEFall:WHEn UNEQual Sets the Rise and Fall trigger condition to unequal (≠).

:TRIGger:RISEFall:TIME

Description	Sets or queries the Rise and Fall time.
Syntax	:TRIGger:RISEFall:TIME {<NRf> ? }
Related commands	:TRIGger:TYPE :TRIGger:RISEFall:WHEn
Parameter	<NRf> Rise and Fall time (4nS to 10S)
Return Parameter	<NR3> Returns the rise and fall time in seconds.
Example	:TRIGger:RISEFall:TIME 4.00E-5 Sets the trigger rise & fall to 40.0us.

Set →

→ Query

:TRIGger:VIDeo:TYPe

Description	Sets or queries the video trigger type.	
Syntax	:TRIGger:VIDeo:TYPe {NTSC PAL SECam EDTV480P EDTV576P HDTV720P HDTV1080I HDTV1080P ? }	
Related commands	:TRIGger:TYPe	
Parameter	NTSC	NTSC
	PAL	PAL
	SECam	SECAM
	EDTV480P	Extra definition TV 480P
	EDTV576P	Extra definition TV 576P
	HDTV720P	High definition TV 720P
	HDTV1080I	High definition TV 1080i
	HDTV1080P	High definition TV 1080P
Return parameter	Returns the video trigger type.	
Example	:TRIGger:VIDeo:TYPe NTSC Sets the video trigger to NTSC.	

Set →

→ Query

:TRIGger:VIDeo:FIELD

Description	Sets or queries the video trigger field.	
Syntax	:TRIGger:VIDeo:FIELD { FIELD1 FIELD2 ALLFields ALLLines ? }	
Related commands	:TRIGger:TYPe	
Parameter	FIELD1	Trigger on field 1
	FIELD2	Trigger on field 2
	ALLFields	Trigger on all fields

ALLLines Trigger on all lines

Return parameter Returns the video trigger field.

Example :TRIGger:VIDeo:FIELD ALLFields
Sets the video trigger to trigger on all fields.

:TRIGger:VIDeo:LINE

Set →

→ Query

Description Sets or queries the video trigger line.

Syntax :TRIGger:VIDeo:LINE {<NR1> | ?}

Related commands :TRIGger:TYPE

Parameter <NR1> Video line

Return parameter <NR3> Returns the video trigger line.

Example :TRIGger:VIDeo:LINE 1
Sets the video trigger to line 1.

Set →

→ Query

:TRIGger:VIDeo:POLarity

Description Sets or queries the video trigger polarity.

Syntax :TRIGger:VIDeo:POLarity { POSitive | NEGative | ? }

Related commands :TRIGger:TYPE

Parameter POSitive Positive polarity

NEGative Negative polarity

Return parameter Returns the video trigger polarity.

Example :TRIGger:VIDeo:POLarity POSitive
Sets the video trigger polarity to positive.

Set →

→ Query

:TRIGger:PULSe:WHEn

Description Sets or queries the pulse width trigger conditions.

Syntax	:TRIGger:PULSe:WHEn { MOREthan LESSthan EQual UNEQual ? }
Related commands	:TRIGger:TYPe :TRIGger:PULSe:TIME
Parameter	MORE than > LESSthan < EQual = UNEQual ≠
Return parameter	Returns the pulse width trigger conditions.

Example :TRIGger:PULSe:WHEn UNEQual
Sets the trigger pulse width conditions to not equal to (≠).

:TRIGger:PULSe:TIME



Description	Sets or queries the pulse width time.
Syntax	:TRIGger:PULSe:TIME {<NRf> ?}
Related commands	:TRIGger:TYPe :TRIGger:PULSe:WHEn
Parameter	<NRf> Pulse width time (4ns~10s)
Return parameter	<NR3> Returns the pulse width time in seconds.

Example :TRIGger:PULSe:TIME 4.00E-5
Sets the trigger pulse width to 40.0us.

:TRIGger:TIMEOut:WHEn



Description	Sets or queries the timeout trigger condition.
Syntax	:TRIGger:TIMEOut:WHEn {HIGH LOW EITHer ?}

Related commands	:TRIGger:TIMEOut:TIMER	
Parameter	HIGH	Signal is high.
	LOW	Signal is low.
	EITHer	Signal is high or low.
Return parameter	Returns the timeout condition (HIGH, LOW, EITHER).	
Example1	:TRIGger:TIMEOut:WHEn LOW Sets the timeout condition to low.	

:TRIGger:TIMEOut:TIMER

Description	Sets or returns timeout trigger time.	
Syntax	:TRIGger:TIMEOut:TIMER {<NRf> ? }	
Related commands	:TRIGger:TIMEOut:WHEn	
Parameter	<NRf>	Timeout time. (4nS to 10S).
Return parameter	Returns the timeout time as <NR3>.	
Example	:TRIGger:TIMEOut:TIMER? 8.960e-05	

:TRIGger:ALTErnate

Description	Sets alternating between source triggers on or off or queries its state.	
Syntax	:TRIGger:ALTErnate {OFF ON ?}	
Parameter	OFF	Alternate off
	ON	Alternate on
Return parameter	Returns the Alternate trigger status (ON, OFF).	
Example	:TRIGger:ALTErnate ON Turns on alternating between source triggers.	

:TRIGger:STATe

→ Query

Description	Returns the current state of the triggering system.	
Syntax	:TRIGger:STATe?	
Return parameter	*ARMED	Indicates that the oscilloscope is acquiring pretrigger information.
	*AUTO	Indicates that the oscilloscope is in the automatic mode and acquires data even in the absence of a trigger.
	*READY	Indicates that all pretrigger information has been acquired and that the oscilloscope is ready to accept a trigger.
	*SAVE	Indicates that the oscilloscope is in save mode and is not acquiring data.
	*TRIGGER	Indicates that the oscilloscope triggered and is acquiring the post trigger information.

Example :TRIGger:STATe?
 AUTO
 The trigger is in auto mode.

Set →

:TRIGger:EXTERnal:PROBE:TYPE

→ Query

Description	Sets or queries the external probe type.	
Syntax	:TRIGger:EXTERnal:PROBE:TYPE { VOLTage CURRent ? }	
Related commands	:TRIGger:EXTERnal:PROBE:RATio	
Parameter	VOLTage	Voltage
	CURRent	Current

Return parameter Returns the probe type.

Example :TRIGger:EXTERnal:PROBe:TYPe?
CURRENT

:TRIGger:EXTERnal:PROBE:RATio (Set) →
← (Query)

Description Sets or queries the external probe ratio (attenuation).

Syntax :TRIGger:EXTERnal:PROBE:RATio {<NRf> | ?}

Related commands :TRIGger:EXTERnal:PROBe:TYPe

Parameter <NRf> External probe attenuation factor.

Return parameter <NR3> Returns the probe attenuation factor.

Example :TRIGger:EXTERnal:PROBE:RATio?
5.000000e+01

:TRIGger:BUS:TYPe → (Query)

Description Returns the current bus type.

Syntax :TRIGger:BUS:TYPe?

Return parameter	I2C	I ² C mode
	SPI	SPI mode
	UART	UART mode
	CAN	CAN mode
	LIN	LIN mode

Example :TRIGger:BUS:TYPe?
UART

:TRIGger:BUS:THReshold:CH<X>



Description	Sets or queries the threshold level for the selected channel.	
Syntax	:TRIGger:BUS:THReshold:CH<X> {<NR3> ?}	
	<X>	CH1 ~ CH4
	<NR3>	Threshold level
Return Parameter	<NR3>	Returns the threshold level
Example	:TRIGger:BUS:THReshold:CH1 1 Sets the CH1 threshold to 1V.	

:TRIGger:BUS:B1:I2C:CONDition



Description	Sets or queries the I ² C trigger conditions.	
Syntax	:TRIGger:BUS:B1:I2C:CONDition {START STOP REPEATstart ACKMISS ADDRess DATA ADDRANDDATA ? }	
Parameter	START	Set Start as the I ² C trigger condition.
	STOP	Set Stop as the I ² C trigger condition.
	REPEATstart	Set Repeat of Start as the I ² C trigger condition.
	ACKMISS	Set Missing Acknowledgement as the I ² C trigger condition.
	ADDRess	Set Address as the I ² C trigger condition.
	DATA	Set Data as the I ² C trigger condition.
	ADDRANDDATA	Set Address and Data as the I ² C trigger condition.

Return parameter Returns the I²C bus trigger condition.

Example :TRIGger:BUS:B1:I2C:CONDition ADDRess
Set Address as the I2C trigger condition.

:TRIGger:BUS:B1:I2C:ADDRess:MODE  

Description Sets or queries the I²C addressing mode (7 or 10 bits).

Syntax :TRIGger:BUS:B1:I2C:ADDRess:MODE {ADDR7 | ADDR10 | ? }

Related commands :TRIGger:BUS:B1:I2C:CONDition

Parameter	ADDR7	7 bit addressing
	ADDR10	10 bit addressing

Return Parameter	0	7 bit addressing
	1	10 bit addressing

Example :TRIGger:BUS:B1:I2C:ADDRess:MODE?
0
The addressing mode is currently set to 7 bits.

:TRIGger:BUS:B1:I2C:ADDRess:TYPE  

Description Sets the I²C bus address type, or queries what the setting is.

Syntax :TRIGger:BUS:B1:I2C:ADDRess:TYPE {GENeralcall | STARtbyte | HSmode | EEPROM | CBUS | ? }

Related commands :TRIGger:BUS:B1:I2C:CONDition

Parameter	GENeralcall	Set a general call address (0000 000 0).
	STARtbyte	Set a start byte address. (0000 000 1)
	HSmode	Set a high-speed mode address. (0000 1xx x)

EEPROM	Set an EEPROM address. (1010 xxx x)
CBUS	Set a CBUS address. (0000 001 x)

Return Parameter Returns the address type

Example :TRIGger:BUS:B1:I2C:ADDRess:TYPe?
CBUS

:TRIGger:BUS:B1:I2C:ADDRess:VALue  

Description Sets or queries the I²C bus address value when the I²C bus is set to trigger on Address or Address/Data.

Syntax :TRIGger:BUS:B1:I2C:ADDRess:VALue {<string> | ? }

Related commands :TRIGger:BUS:B1:I2C:ADDRess:MODE

Parameter	<sting>	7/10 characters, must be enclosed in double quotes, "string". x = don't care 1 = binary 1 0 = binary 0
-----------	---------	---

Return Parameter Returns the address value.

Example1 :TRIGger:BUS:B1:I2C:ADDRess:MODE ADDR7
:TRIGger:BUS:B1:I2C:ADDRess:VALue "xxx0101"
Sets the address to XXX0101

Example 2 :TRIGger:BUS:B1:I2C:ADDRess:VALue?
XXX0101

:TRIGger:BUS:B1:I2C:ADDRess:DIRection  

Description Sets or queries the address bit as read write or don't care.

Note	This setting only applies when the I ² C trigger is set to trigger on Address or Address/Data	
Syntax	:TRIGger:BUS:B1:I2C:ADDReSS:DIRection { READ WRITE NOCARE ? }	
Related commands	:TRIGger:BUS:B1:I2C:CONDition	
Parameter	READ	Set read as the data direction.
	WRITE	Set write as the data direction.
	NOCARE	Set either as the data direction.
Return Parameter	Returns the direction (READ, WRITE, NOCARE).	
Example	:TRIGger:BUS:B1:I2C:ADDReSS:DIRection READ Sets the direction to READ.	

Set →
 → Query

Description	Sets or queries the data size in bytes for the I ² C bus.	
Note	This setting only applies when the I ² C trigger is set to trigger on Data or Address/Data	
Syntax	:TRIGger:BUS:B1:I2C:DATA:SIZE {<NR1> ? }	
Related commands	:TRIGger:BUS:B1:I2C:CONDition	
Parameter	<NR1>	Number of data bytes (1 to 5).
Return parameter	<NR1>	Returns the number of bytes.
Example	:TRIGger:BUS:B1:I2C:DATA:SIZE 3 Sets the number of bytes to 3.	

Set →
 → Query

Description	Sets or queries the triggering data value for the I ² C bus when the I ² C bus is set to trigger on Data or Address/Data.	
-------------	---	--

Syntax	:TRIGger:BUS:B1:I2C:DATA:VALue {<string> ? }	
Related commands	:TRIGger:BUS:B1:I2C:DATA:SIZE	
Parameter	<sting>	The number of characters in the string depends on the data size setting. The string must be enclosed in double quotes, "string". x = don't care 1 = binary 1 0 = binary 0

Return Parameter Returns the data value.

Example1 :TRIGger:BUS:B1:I2C:DATA:SIZE 1
:TRIGger:BUS:B1:I2C:DATA:VALue "1x1x0101"
Sets the value to XXX0101

Example 2 :TRIGger:BUS:B1:I2C:DATA:VALue?
1X1X0101

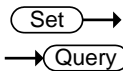

:TRIGger:BUS:B1:UART:CONDition

Description	Sets or queries the UART triggering condition.	
Syntax	:TRIGger:BUS:B1:UART:CONDition { RXSTArt RXDATA RXENDPacket TXSTArt TXDATA TXENDPacket TXPARItYerr RXPARItYerr ? }	
Parameter	RXSTArt	Set trigger on the RX Start Bit.
	RXDATA	Set trigger on RX Data.
	RXENDPacket	Set trigger on the RX End of Packet condition.
	RXPARItYerr	Set trigger on RX Parity error condition.
	TXSTArt	Set trigger on the TX Start Bit.
	TXDATA	Set trigger on TX Data.

TXENDPacket	Set trigger on the TX End of Packet condition.
TXPARIttyerr	Set trigger on TX Parity error condition.

Return Parameter Returns the triggering condition.

Example :TRIGger:BUS:B1:UART:CONDition TXDATA
Sets the UART bus to trigger on Tx Data.

:TRIGger:BUS:B1:UART:RX:DATA:SIZE (Set) →
→ (Query)

Description Sets or queries the number of bytes for UART data.

Note This setting only applies when the UART trigger is set to trigger on Rx Data

Syntax :TRIGger:BUS:B1:UART:RX:DATA:SIZE {<NR1> | ?}

Related commands :TRIGger:BUS:B1:UART:CONDition

Parameter <NR1> Number of bytes (1 to 10).

Return parameter <NR1> Returns the number of bytes.

Example :TRIGger:BUS:B1:UART:RX:DATA:SIZE 5
Sets the number of bytes to 5.

:TRIGger:BUS:B1:UART:RX:DATA:VALue (Set) →
→ (Query)

Description Sets or queries the triggering data value for the UART bus when the bus is set to trigger on Rx Data.

Syntax :TRIGger:BUS:B1:UART:RX:DATA:VALue {<string> | ?}

Related commands :TRIGger:BUS:B1:UART:RX:DATA:SIZE

Parameter <sting> The number of characters in the string depends on the data size setting. The string must be enclosed in double quotes, "string".

Related commands	:TRIGger:BUS:B1:UART:TX:DATA:SIZE	
Parameter	<string>	The number of characters in the string depends on the data size setting. The string must be enclosed in double quotes, "string". x = don't care 1 = binary 1 0 = binary 0

Return Parameter Returns the data value.

Example 1 :TRIGger:BUS:B1:UART:CONDition TXDATA
:TRIGger:BUS:B1:UART:TX:DATA:SIZE 1
:TRIGger:BUS:B1:UART:TX:DATA:VALue "1x1x0101"
Sets the value to 1x1x0101

Example 2 :TRIGger:BUS:B1:UART:TX:DATA:VALue?
1X1X0101

:TRIGger:BUS:B1:SPI:CONDition  

Description	Sets or queries the SPI triggering condition.	
Syntax	:TRIGger:BUS:B1:SPI:CONDition {SS MISO MOSI MISOMOSI ? }	
Parameter	SS	Set to trigger on the Slave Selection condition.
	MISO	Set to trigger on the Master-In Slave-Out condition.
	MOSI	Set to trigger on the Master-Out Slave-In condition.
	MISOMOSI	Set to trigger on the Master-In Slave-Out and Master-Out Slave-In conditions.

Return Parameter Returns the triggering condition.

Example :TRIGger:BUS:B1:SPI:CONDition MISO
Sets the SPI bus to trigger on MISO.

:TRIGger:BUS:B1:SPI:DATA:SIZE (Set) →
→ (Query)

Description	Sets or queries the number of words for SPI data.	
Note	This setting only applies when the SPI trigger is set to trigger on MISO, MOSI or MISO/MOSI	
Syntax	:TRIGger:BUS:B1:SPI:DATA:SIZE {<NR1> ?}	
Related commands	:TRIGger:BUS:B1:SPI:CONDition	
Parameter	<NR1>	Number of words (1 to 32).
Return parameter	<NR1>	Returns the number of words.
Example	:TRIGger:BUS:B1:SPI:DATA:SIZE 10 Sets the number of words to 10.	

:TRIGger:BUS:B1:SPI:DATA:MISO:VALue (Set) →
→ (Query)

Description	Sets or queries the triggering data value for the SPI bus when the bus is set to trigger on MISO or MISO/MOSI.	
Syntax	:TRIGger:BUS:B1:SPI:DATA:MISO:VALue {<string> ?}	
Related commands	:TRIGger:BUS:B1:SPI:DATA:SIZE	
Parameter	<sting>	The number of characters in the string depends on the data size setting. The string must be enclosed in double quotes, "string". x = don't care 1 = binary 1 0 = binary 0

Return Parameter Returns the data value.

Example1 :TRIGger:BUS:B1:SPI:CONDition MISO
 :TRIGger:BUS:B1:SPI:DATA:SIZE 2
 :TRIGger:BUS:B1:SPI:DATA:MISO:VALue "1x1x0101"
 Sets the value to 1x1x0101

Example 2 :TRIGger:BUS:B1:SPI:DATA:MISO:VALue?
 1X1X0101

:TRIGger:BUS:B1:SPI:DATA:MOSI:VALue 

Description Sets or queries the triggering data value for the SPI bus when the bus is set to trigger on MOSI or MISO/MOSI.

Syntax :TRIGger:BUS:B1:SPI:DATA:MOSI:VALue {<string> | ? }

Related commands :TRIGger:BUS:B1:SPI:DATA:SIZE

Parameter	<string>	The number of characters in the string depends on the data size setting. The string must be enclosed in double quotes, "string". x = don't care 1 = binary 1 0 = binary 0
-----------	----------	--

Return Parameter Returns the data value.

Example1 :TRIGger:BUS:B1:SPI:CONDition MOSI
 :TRIGger:BUS:B1:SPI:DATA:SIZE 2
 :TRIGger:BUS:B1:SPI:DATA:MOSI:VALue "1x1x0101"
 Sets the value to 1x1x0101

Example2 :TRIGger:BUS:B1:SPI:DATA:MOSI:VALue?
 1X1X0101

:TRIGger:BUS:B1:CAN:CONDition



Description	Sets or returns the CAN trigger condition.	
Syntax	:TRIGger:BUS:B1:CAN:CONDition {SOF FRAMeType IDentifier DATA IDANDDATA EOF ACKMISS STUFFERR ?}	
Parameter/ Return parameter	SOF	Triggers on a start of frame
	FRAMeType	Triggers on the type of frame
	IDentifier	Triggers on a matching identifier
	DATA	Triggers on matching data
	IDANDDATA	Triggers on matching identifier and data field
	EOF	Triggers on the end of frame
	ACKMISS	Triggers on a missing acknowledge
	STUFFERR	Triggers on a bit stuffing error

Example1 :TRIGger:BUS:B1:CAN:CONDition SOF
Triggers on a start of frame.

Example2 :TRIGger:BUS:B1:CAN:CONDition?
>SOF

:TRIGger:BUS:B1:CAN:FRAMeType



Description	Sets or returns the frame type for a CAN FRAMeType trigger.	
Syntax	:TRIGger:BUS:B1:CAN:FRAMeType {DATA REMote ERRor OVERLoad ?}	
Parameter/ Return parameter	DATA	Sets the frame type to data frame
	REMote	Sets the frame type to remote frame
	ERRor	Sets the frame type to error frame
	OVERLoad	Sets the frame type to overload

Example :TRIGger:BUS:B1:CAN:FRAMeType DATA
Sets the frame type to DATA.

:TRIGger:BUS:B1:CAN:IDentifier:MODE  

Description Sets or returns the CAN identifier mode for the bus.

Syntax :TRIGger:BUS:B1:CAN:IDentifier:MODE {STANDard|EXTended|?}

Parameter/	STANDard	Standard addressing mode
Return parameter	EXTended	Extended addressing mode

Example :TRIGger:BUS:B1:CAN:IDentifier:MODE?>STANDARD
Returns the addressing mode.

:TRIGger:BUS:B1:CAN:IDentifier:VALue  

Description Sets or returns the identifier string used for the CAN trigger.
Note: Only applicable when the trigger condition is set to ID or IDANDDATA.

Syntax :TRIGger:BUS:B1:CAN:IDentifier:VALue {<string>|?}

Related Commands :TRIGger:BUS:B1:CAN:IDentifier:MODE

Parameter/	<string>	The size of the string depends on the data size setting. The string must be enclosed in double quotes, "string". String contents: x = don't care 1 = binary 1 0 = binary 0
Return parameter		

```
Example      :TRIGger:BUS:B1:CAN:CONDition ID
              :TRIGger:BUS:B1:CAN:IDentifier:MODE STANDARD
              :TRIGger:BUS:B1:CAN:IDentifier:VALue
              "01100X1X01X"
              :TRIGger:BUS:B1:CAN:IDentifier:VALue?
              >01100X1X01X
```

Set →

```
:TRIGger:BUS:B1:CAN:IDentifier:DIRection → Query
```

Description Sets or queries the address bit as read, write or don't care.

Syntax :TRIGger:BUS:B1:CAN:IDentifier:DIRection
{READ|WRITE|NOCARE|?}

Parameter/ Return parameter	READ	Sets read as the data direction
	WRITE	Sets write as the data direction
	NOCARE	Sets either as the data direction

Example1 :TRIGger:BUS:B1:CAN:IDentifier:DIRection?
>WRITE

Example2 :TRIGger:BUS:B1:CAN:IDentifier:DIRection READ
:TRIGger:BUS:B1:CAN:IDentifier:DIRection?
> READ

Set →

```
:TRIGger:BUS:B1:CAN:DATA:QUALifier → Query
```

Description Sets or returns the CAN data qualifier.
Note: Only applicable when the triggering condition is set to DATA or IDANDDATA.

Syntax :TRIGger:BUS:B1:CAN:DATA:QUALifier
{LESSthan|MOREthan|Equal|UNEQual|LESSEQual|M
OREEQual|?}

Parameter/ Return parameter	LESSthan	Triggers when the data is less than the qualifier value.
--	----------	--

MOREthan	Triggers when the data is greater than the qualifier value.
EQual	Triggers when the data is equal to the qualifier value.
UNEQual	Triggers when the data is not equal to the qualifier value.
LESSEQual	Triggers when the data is less than or equal to the qualifier value.
MOREEQual	Triggers when the data is more than or equal to the qualifier value.

Example :TRIGger:BUS:B1:CAN:DATA:QUALifier?
 >EQUAL
 :TRIGger:BUS:B1:CAN:DATA:QUALifier MOREthan
 :TRIGger:BUS:B1:CAN:DATA:QUALifier?
 >MOREthan

:TRIGger:BUS:B1:CAN:DATA:SIZE (Set) →
 → (Query)

Description Sets or returns the length of the data string in bytes for a CAN trigger.
 Note: Only applicable when the condition is set to DATA or IDANDDATA.

Syntax :TRIGger:BUS:B1:CAN:DATA:SIZE {<NR1>|?}

Parameter/ Return parameter <NR1> 1~8 (bytes)

Example :TRIGger:BUS:B1:CAN:DATA:SIZE?
 >1
 :TRIGger:BUS:B1:CAN:DATA:SIZE 2
 :TRIGger:BUS:B1:CAN:DATA:SIZE?
 >2

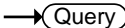
		 
:TRIGger:BUS:B1:CAN:DATA:VALue		
Description	Sets or returns the binary data string to be used for a CAN trigger. Note: Only applicable when the condition is set to DATA or IDANDDATA.	
Related Commands	:TRIGger:BUS:B1:CAN:DATA:SIZE	
Syntax	:TRIGger:BUS:B1:CAN:DATA:VALue {<string> ?}	
Parameter/ Return parameter	<string>	The size of the string depends on the data size setting. The string must be enclosed in double quotes, "string". String contents: x = don't care 1 = binary 1 0 = binary 0
Example	:TRIGger:BUS:B1:CAN:DATA:SIZE 1 :TRIGger:BUS:B1:CAN:DATA:VALue "01010X1X" :TRIGger:BUS:B1:CAN:DATA:VALue? >01010X1X	

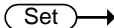
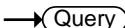
		 
:TRIGger:BUS:B1:LIN:CONDition		
Description	Sets or returns the LIN trigger condition.	
Syntax	:TRIGger:BUS:B1:LIN:CONDition {SYNCField IDentifier DATA IDANDDATA WAKEup SLEEP ERRor ?}	
Parameter/ Return parameter	SYNCField	Sets the LIN trigger condition to the sync field.
	IDentifier	Sets the LIN trigger condition to identifier field.

DATA	Sets the LIN trigger condition to the data field.
IDANDDATA	Sets the LIN trigger condition to identifier and data field
WAKEup	Sets the LIN trigger condition to wake up.
SLEEP	Sets the LIN trigger condition to sleep.
ERRor	Sets the LIN trigger condition to error.

Example :TRIGger:BUS:B1:LIN:CONDition?
 >IDANDDATA
 :TRIGger:BUS:B1:LIN:CONDition DATA
 :TRIGger:BUS:B1:LIN:CONDition?
 >DATA

:TRIGger:BUS:B1:LIN:DATA:QUALifier 

Description Sets or returns the LIN data qualifier.
 Note: Only applicable when the trigger condition is set to DATA or IDANDDATA.

Syntax :TRIGger:BUS:B1:LIN:DATA:QUALifier
 {LESSthan|MOREthan|EQual|UNEQual|LESSEQual|M
 OREEQual|?}

Parameter/ Return parameter	LESSthan	Triggers when the data is less than the qualifier value.
	MOREthan	Triggers when the data is greater than the qualifier value.
	EQual	Triggers when the data is equal to the qualifier value.
	UNEQual	Triggers when the data is not equal to the qualifier value.
	LESSEQual	Triggers when the data is less than or equal to the qualifier value.

MOREEqual Triggers when the data is more than or equal to the qualifier value.

Example :TRIGger:BUS:B1:LIN:DATA:QUALifier?
>EQUAL
:TRIGger:BUS:B1:LIN:DATA:QUALifier MOREthan
:TRIGger:BUS:B1:LIN:DATA:QUALifier?
>MORETHAN

:TRIGger:BUS:B1:LIN:DATA:SIZE (Set) →
← (Query)

Description Sets or returns the length of the data string in bytes for the LIN trigger.
Note: Only applicable when the condition is set to DATA or IDANDDATA.

Syntax :TRIGger:BUS:B1:LIN:DATA:SIZE {<NR1>|?}

Parameter/ Return parameter <NR1> 1~8 (bytes)

Example :TRIGger:BUS:B1:LIN:DATA:SIZE?
>1
:TRIGger:BUS:B1:LIN:DATA:SIZE 2
:TRIGger:BUS:B1:LIN:DATA:SIZE?
>2

:TRIGger:BUS:B1:LIN:DATA:VALue (Set) →
← (Query)

Description Sets or returns the binary data string to be used for the LIN trigger.
Note: Only applicable when the condition is set to DATA or IDANDDATA.

Related Commands :TRIGger:BUS:B1:LIN:DATA:SIZE

Syntax :TRIGger:BUS:B1:LIN:DATA:VALue {<string>|?}

Parameter/ Return parameter	<string>	The size of the string depends on the data size setting. The string must be enclosed in double quotes, "string". String contents: x = don't care 1 = binary 1 0 = binary 0
--------------------------------	----------	--

Example :TRIGger:BUS:B1:LIN:DATA:SIZE 1
:TRIGger:BUS:B1:LIN:DATA:VALue "01010X1X"
:TRIGger:BUS:B1:LIN:DATA:VALue?
>01010X1X

Set →
 → Query

Description Sets or returns the error type be used for the LIN trigger.

Syntax :TRIGger:BUS:B1:LIN:ERRTYPE
{SYNC|PARItY|CHecksum|?}

Parameter/ Return parameter	SYNC	Sets the LIN error type to SYNC.
	PARItY	Sets the LIN error type to parity.
	CHecksum	Sets the LIN error type to checksum.

Example :TRIGger:BUS:B1:LIN:ERRTYPE?
>SYNC
:TRIGger:BUS:B1:LIN:ERRTYPE CHECKSUM
:TRIGger:BUS:B1:LIN:ERRTYPE?
>CHECKSUM

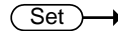

:TRIGger:BUS:B1:LIN:IDentifier:VALue

Description	Sets or returns the identifier string to be used for the LIN trigger. Note: Only applicable when the condition is set to ID or IDANDDATA.	
Syntax	:TRIGger:BUS:B1:LIN:IDentifier:VALue {<string> ?}	
Parameter/ Return parameter	<string>	The size of the string depends on the data size setting. The string must be enclosed in double quotes, "string". String contents: x = don't care 1 = binary 1 0 = binary 0
Example	:TRIGger:BUS:B1:LIN:CONDition ID :TRIGger:BUS:B1:LIN:IDentifier:VALue "00X1X01X" :TRIGger:BUS:B1:LIN:IDentifier:VALue? >01100X1X01X	



:TRIGger:LOGic:INPut:CLOCK:SOURce

Description	Sets or returns which digital channel is used as the clock source for the logic trigger. If none are selected, a pattern trigger will have to be used.	
Syntax	:TRIGger:LOGic:INPut:CLOCK:SOURce {NONE D0 D1 D2 D3 D4 D5 D6 D7 D8 D9 D10 D11 D12 D13 D14 D15 ?}	
Parameter/ Return parameter	None D0~D15	No clock source selected. A pattern trigger will have to be set. Sets one of the digital channels as the clock source.

Example :TRIG:LOG:INP:CLOCK:SOUR D0
 :TRIG:LOG:INP:CLOCK:SOUR?
 >D0

:TRIGger:LOGic:INPut:CLOCK:EDGE (Set) →

Description Sets the polarity of the clock source.

Syntax :TRIGger:LOGic:INPut:CLOCK:EDGE {RISe | FALL | EITher}

Related Commands :TRIGger:LOGic:INPut:CLOCK:SOURce

Parameter	RISe	Sets the clock source on the rising edge.
	FALL	Sets the clock source on the falling edge.
	EITher	Sets the clock source to either rising or falling edge.

Example :TRIG:LOG:INP:CLOCK:EDG RIS

(Set) →

:TRIGger:LOGic:FUNCTion → (Query)

Description Sets or queries the logical combination of the digital channels for the logic trigger.

Syntax :TRIGger:LOGic:FUNCTion{AND | NAND | NOR | OR | ?}

Related Commands :TRIGger:LOGic:PATtern:INPut:D<x>

Parameter/ Return parameter	AND	Sets the logic combination to AND.
	NAND	Sets the logic combination to NAND.
	NOR	Sets the logic combination to NOR.
	OR	Sets the logic combination to OR.

Example :TRIGger:LOGic:FUNcTION?
 >AND
 :TRIGger:LOGic:FUNcTION NAND
 Sets the logic combination of the digital channels to NAND.

:TRIGger:LOGic:PATtern → Query

Description Queries the conditions used for generating a logic pattern trigger in terms of input pattern, pattern trigger time and conditions.

Syntax :TRIGger:LOGic:PATtern?

Example :TIGger:LOGic:PATtern?
 >:TRIGGER:LOGIC:PATTERN:INPUT:D0 HIGH; D1 X;
 D2 X; D3 X; D4 X; D5 X; D6 X; D7 X; D8 X; D9 X; D10
 X; D11 X; D12 X; D13 X; D14 X; D15 X;
 :TRIGGER:LOGIC:PATTERN:WHEN TRUE;
 :TRIGGER:LOGIC:PATTERN:DELTATIME 1.000e-08;

Set →

:TRIGger:LOGic:PATtern:INPut:D<x> → Query

Description Sets or returns the logic level for the selected digital channel.

Syntax :TRIGger:LOGic:PATtern:INPut:D<x> {HIGH | LOW | X | ?}

Related Commands :TRIGger:LOGic:FUNcTION

Parameter/ Return parameter	<x>	Digital channel number 0~15.
	HIGH	Sets to logical high state.
	LOW	Sets to logical low state.
	X	Sets to "don't care" state.

Example :TRIGger:LOGic:PATtern:INPut:D0?
 >HIGH

Set →
→ Query

:TRIGger:LOGic:PATtern:DELTatime

Description	Sets or returns the pattern trigger delta time value.	
Syntax	:TRIGger:LOGic:PATtern:DELTatime {<NR3> ?}	
Related Commands	:TRIGger:LOGic:PATtern:WHEn	
Parameter/ Return parameter	<NR3>	Pattern trigger time value in seconds 1e-9 (1 ns) to 10.0e0 (10 s).
Example	:TRIG:LOG:PAT:DELT 8.960e-05 :TRIG:LOG:PAT:DELT? >8.960e-05	

Set →
→ Query

:TRIGger:LOGic:PATtern:WHEn

Description	Sets or returns the pattern logic condition on which to trigger the oscilloscope.	
Syntax	:TRIGger:LOGic:PATtern:WHEn {TRUE FALSE LESSthan MOREthan EQUAL UNEQual ?}	
Related Commands	:TRIGger:LOGic:PATtern:DELTatime	
Parameter/ Return parameter	TRUE	Triggers when the defined input pattern is met.
	FALSE	Triggers when the defined input pattern is not met.
	LESSthan	Triggers when the defined input pattern is met during a time lower than the defined delta time.
	MOREthan	Triggers when the defined input pattern is met during a time greater than the defined delta time.

EQUAL	Triggers when the defined input pattern is met during a time equal to the defined delta time.
UNEQUAL	Triggers when the defined input pattern is met during a time other than the defined delta time.

Example

```
:TRIG:LOG:PAT:DELT FALSE
:TRIG:LOG:PAT:DELT?
>FALSE
```

System Commands

:SYSTem:LOCK	163
:SYSTem:ERRor.....	163

:SYSTem:LOCK

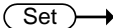

Description	Turns the panel lock on off.	
Syntax	:SYSTem:LOCK {OFF ON ? }	
Parameter	OFF	System lock off
	ON	System lock on
Return parameter	Returns the status of the panel lock (ON, OFF).	
Example	:SYSTem:LOCK ON Turns the panel lock on.	

:SYSTem:ERRor



Description	Queries the error queue. See the appendix on page 278 for details.	
Syntax	:SYSTem:ERRor?	
Return parameter	Returns the last message in the error queue.	
Example	:SYSTem:ERRor? +0, "No error."	

Save/Recall Commands

:RECALL:SETUp	164
:RECALL:WAVEform	164
:SAVE:IMAGe	165
:SAVE:IMAGe:FILEFormat.....	165
:SAVE:IMAGe:INKSaver.....	166
:SAVE:SETUp	166
:SAVE:WAVEform.....	167
:SAVE:WAVEform:FILEFormat	168

:RECALL:SETUp



Description	Recalls setup settings from memory or USB.	
Syntax	:RECALL:SETUp {S1~S20 <file path>("Disk:/xxx.SET", "USB:/xxx.SET")}	
Parameter	S1~S20	Recall Set1~Set20
	<file path>	Recall a file from the DSO internal files system or from a USB flash drive.
Example	<p>:RECALL:SETUp S1 Recalls setup setting S1 from memory.</p> <p>:RECALL:SETUp "Disk:/DS0001.SET" Recall the setup setting DS0001.SET from the internal memory.</p>	

:RECALL:WAVEform



Description	Recalls a waveform from wave1~wave20 or from file to REF1~4.	
Note	Detail CSV files cannot be recalled.	
Syntax	:RECALL:WAVEform {W<n> <file path> ("Disk:/xxx.LSF", "USB:/xxx.LSF")}, REF<X>	

Parameter	n	1~20 (Wave1~wave20)
	<file page>	Filename in file path. Example: “Disk:/xxx.LSF”, “USB:/xxx.LSF”, “Disk:/xxx.CSV”, “USB:/xxx.CSV”
	<X>	1,2,3,4 (REF1, REF2, REF3, REF4)

Example :RECALL:WAVEform W1, REF1
 Recalls the waveform stored in Wave1 to reference 1.

:SAVe:IMAGe



Description	Saves a screen image to the assigned file path with a specified filename.	
Syntax	:SAVe:IMAGe {<file path> (“Disk:/xxx.PNG”, “USB:/xxx.BMP”)}	
Related commands	:SAVe:IMAGe:FILEFormat :SAVe:IMAGe:INKSaver	
Parameter	xxx.PNG or xxx.BMP	File name (8 characters max)

Example :SAVe:IMAGe “Disk:/pic1.PNG”
 Saves a screen image named pic1.png to the root directory (Disk:/) of the scope.
 :SAVe:IMAGe “USB:/pic1.BMP”
 Saves a screen image named pic1.bmp to the root directory of the external USB flash disk.

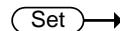

:SAVe:IMAGe:FILEFormat

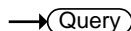

Description	Sets the file format for image.	
Syntax	:SAVe:IMAGe:FILEFormat {PNG BMP ?}	
Related commands	:SAVe:IMAGe :SAVe:IMAGe:INKSaver	

Parameter	PNG	Sets the file format to PNG
	BMP	Sets the file format to BMP
Return parameter	Returns the file format (PNG, BMP).	
Example	:SAVE:IMAGe:FILEFormat PNG Sets the image file format to PNG.	

Set →

→ Query

:SAVE:IMAGe:INKSaver

Description	Turns Ink Saver on or off.	
Syntax	:SAVE:IMAGe:INKSaver {OFF ON ?}	
Related commands	:SAVE:IMAGe :SAVE:IMAGe:FILEFormat	
Parameter	OFF	Turns Inksaver off.
	ON	Turns Inksaver on.
Return parameter	Returns Ink Saver status (ON, OFF).	
Example	:SAVE:IMAGe:INKSaver ON Turns Ink Saver on.	

:SAVE:SETUp

Set →

Description	Saves the current setup to internal memory (Set1~Set20) or the designated file path.	
Syntax	:SAVE:SETUp {<file path> ("Disk:/xxx.SET", "USB:/xxx.SET) S1~S20}	
Parameter	S1~S20	Saves the setup to Set1~Set20
	File path	Saves the setup to disk to the specified file path.

Example :SAVe:SETUp S1
 Saves the current setup to Set1 in internal memory.
 :SAVe:SETUp "Disk:/DS0001.SET"
 Saves the current setup to DS0001.SET in the root directory of the internal memory.

:SAVe:WAVEform Set →

Description Saves a waveform to internal memory or to a designated file path.

Related commands :SAVe:WAVEform:FILEFormat

Syntax :SAVe:WAVEform {CH1~REF4, REF<X> } | {CH1~REF4, W1~W20} | {CH1~ALL, file path}

Parameter	CH1~REF4, <X> W1~W20 ALL File path	CH1~CH4, Math, D0~D15, REF1~4 1,2,3,4 (REF1, REF2, REF3, REF4) Wave1~Wave20 All the displayed waveforms on screen. Saves the waveform(s) to disk or USB to the specified file path. (LSF or CSV, but note that detail CSV can't be recalled to the scope.)
------------------	---	--

Example 1 :SAVe:WAVEform CH1, REF2
 Saves the channel1 waveform to REF2.

Example 2 :SAVe:WAVEform:FILEFormat LSF
 :SAVe:WAVEform ALL, "Disk:/ALL001"
 Sets the file format to LSF. A folder named "ALL001" is created and saves all displayed waveforms to the "ALL001" directory in the LSF format.

Example 3 :SAVE:WAVEform:FILEFormat FCSV
 :SAVE:WAVEform ALL, "Disk:/ALL002"
 Sets the file format to FCSV(fast CSV format). It then saves the all channel's waveforms to the root directory (Disk:/) of the internal flash disk in the CSV format (with the filename ALL002.CSV).

Example 4 :SAVE:WAVEform:FILEFormat LSF
 :SAVE:WAVEform CH2, "Disk:/DS0003.LSF"
 Save the channel 2's waveform to the root directory (Disk:/) of the internal flash disk in the LSF format with DS0003.LSF as the filename.

:SAVE:WAVEform:FILEFormat
 →
 ←

Description	Sets the waveform savefile format.	
Syntax	:SAVE:WAVEform:FILEFormat {LSF DCSV FCSV ?}	
Parameter	LSF	Sets the file format to the MSO-2000E/2000EA's internal file format, LSF. (xxx.LSF) (no support LA)
	DCSV	Sets the file format to detail CSV. (xxx.CSV)
	FCSV	Sets the file format to fast CSV. (xxx.CSV)
Return parameter	Returns the file format (LSF , DCSV, FCSV).	

Example :SAVE:WAVEform:FILEFormat LSF
 Sets the file format to LSF.

Ethernet Commands

:ETHERnet:DHCP169

:ETHERnet:DHCP

Set →

→ Query

Description	Sets or queries the DHCP settings.	
Syntax	:ETHERnet:DHCP { OFF ON ? }	
Parameter	ON	Turns DHCP on.
	OFF	Turns DHCP off.
Example	:ETHERnet:DHCP ON Turns DHCP on.	

Time Commands

:DATE170

:DATE



Description	Sets the system date and time.	
Syntax	:DATE {<string>}	
Parameter	<string>	"YYYYMMDDhhmmss" Where: YYYY: year MM: month DD: day hh: hour mm: minute ss: second
Example	:DATE "20140802142830" Sets the time and date as: Year: 2014, Month: 08, Day: 02, Hour: 14 (2PM), Minute: 28, Second: 30.	

Bus Decode Commands

:BUS1	172
:BUS1:STATE	172
:BUS1:TYPe	172
:BUS1:INPut.....	173
:BUS1:I2C:ADDRes:RWINClude.....	173
:BUS1:I2C:SCLK:SOURce	174
:BUS1:I2C:SDA:SOURce.....	174
:BUS1:UART:BITRate.....	174
:BUS1:UART:DATABits	175
:BUS1:UART:PARItY.....	175
:BUS1:UART:PACKEt	175
:BUS1:UART:EOFPacket	176
:BUS1:UART:TX:SOURce	176
:BUS1:UART:RX:SOURce	177
:BUS1:SPI:SCLK:POLARity	177
:BUS1:SPI:SS:POLARity.....	177
:BUS1:SPI:WORDSize	178
:BUS1:SPI:BITORder	178
:BUS1:SPI:SCLK:SOURce	178
:BUS1:SPI:SS:SOURce.....	179
:BUS1:SPI:MOSI:SOURce	179
:BUS1:SPI:MISO:SOURce	179
:BUS1:DISPlay:FORMAt	180
:LISTer:DATA	180
:BUS1:CAN:SOURce.....	181
:BUS1:CAN:PROBe.....	181
:BUS1:CAN:SAMPLEpoint.....	181
:BUS1:CAN:BITRate.....	182
:BUS1:LIN:BITRate	183
:BUS1:LIN:IDFORmat	183
:BUS1:LIN:POLARity.....	183
:BUS1:LIN:SAMPLEpoint	183

:BUS1:LIN:SOURce184
 :BUS1:LIN:STANDard184

:BUS1 → Query

Description	Returns the supported BUS types.
Syntax	:BUS1?
Return Parameter	Returns the supported bus types.
Example	BUS1? I2C,SPI,UART,CAN,LIN

Set →
→ Query

:BUS1:STATE

Description	Sets or queries the state of the bus.	
Syntax	:BUS1:STATE { OFF ON ? }	
Related commands	:BUS1:TYPE	
Parameter/Return parameter	OFF	Turns the bus off.
	ON	Turns the bus on.
Example	:BUS1:STATE ON Turns the bus on.	

Set →
→ Query

:BUS1:TYPE

Description	Sets or queries the type of bus.	
Syntax	:BUS1:TYPE { UART I2C SPI PARAllel CAN LIN ? }	
Related commands	:BUS1:STATE	
Parameter/Return parameter	UART	Sets the bus to UART mode.
	I2C	Sets the bus to I ² C mode.

SPI	Sets the bus to SPI mode.
PARAllel	Sets the bus to parallel mode.
CAN	Sets the bus to CAN mode.
LIN	Sets the bus to LIN mode.

Example :BUS1:TYPe SPI
Sets the bus to SPI mode.

:BUS1:INPut

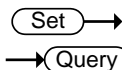

Description	Sets or returns the bus source.	
Syntax	:BUS1:INPut {ANALog DIGital ?}	
Parameter/Return parameter	ANALog	Sets the bus source as analog inputs.
	DIGital	Sets the bus source as digital inputs.

Example1 :BUS1:INPut?
>ANALOG

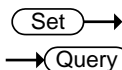

:BUS1:I2C:ADDRes:RWINClude

Description	Sets or queries whether the read/write bit is included in the I ² C address.	
Syntax	:BUS1:I2C:ADDRes:RWINClude { OFF ON ? }	
Related commands	:BUS1:STATE	
Parameter	OFF	The R/W bit is not included.
	ON	The R/W bit is included.
Return parameter	0	The R/W bit is not included.
	1	The R/W bit is included.

Example :BUS1:I2C:ADDRes:RWINClude ON
Includes the R/W bit in the I²C address.

:BUS1:I2C:SCLK:SOURce (Set) →
→ (Query)

Description	Sets or queries which channel is used for the I ² C SCLK source.
Syntax	:BUS1:I2C:SCLK:SOURce { CH1 CH2 CH3 CH4 D0 D1 D2 D3 D4 D5 D6 D7 D8 D9 D10 D11 D12 D13 D14 D15 ? }
Parameter/Return parameter	CH1 to CH4 Analog channels 1 ~ 4. D0 to D15 Digital channels D0~D15
Example	:BUS1:I2C:SCLK:SOURce CH1 Sets channel 1 as the SCLK source.

:BUS1:I2C:SDA:SOURce (Set) →
→ (Query)

Description	Sets or queries which channel is used for the I ² C SDA source.
Syntax	:BUS1:I2C:SDA:SOURce { CH1 CH2 CH3 CH4 D0 D1 D2 D3 D4 D5 D6 D7 D8 D9 D10 D11 D12 D13 D14 D15 ? }
Parameter/Return parameter	CH1 to CH4 Analog channels 1 ~ 4. D0 to D15 Digital channels D0~D15
Example	:BUS1:I2C:SDA:SOURce CH1 Sets channel 1 as the SDA source.

:BUS1:UART:BITRate (Set) →
→ (Query)

Description	Sets or queries the UART bit rate.
Syntax	:BUS1:UART:BITRate { <NR1> ? }
Parameter/Return parameter	<NR1> UART bit rate in bps

Example :BUS1:UART:BITRate?
 >2400
 :BUS1:UART:BITRate 50
 :BUS1:UART:BITRate?
 >50

:BUS1:UART:DATABits

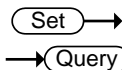

Description	Sets or queries the number UART data for bus 1.	
Syntax	:BUS1:UART:DATABits { 5 6 7 8 9 ? }	
Parameter/Return parameter	5	5 data bits in the UART frame.
	6	6 data bits in the UART frame.
	7	7 data bits in the UART frame.
	8	8 data bits in the UART frame.

Example :BUS1:UART:DATABits 7
 Sets the UART frame to 7 bits.

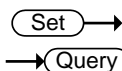

:BUS1:UART:PARITY

Description	Sets or queries the UART bus parity.	
Syntax	:BUS1:UART:PARITY { <NR1> ? }	
Parameter/Return parameter	<NR1>	0: None
		1: Odd parity
		2: Even parity

Example :BUS1:UART:PARITY 1
 Sets the parity to odd.

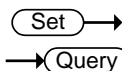

:BUS1:UART:PACKET

Description	Sets or queries the UART packet setting.	
Syntax	:BUS1:UART:PACKET {<NR1> ? }	

Parameter/Return parameter	<NR1>	0: Off 1: On
----------------------------	-------	-----------------

Example :BUS1:UART:PACKet 1
Turns UART packets on.

Set →

:BUS1:UART:EOFPacket

→ Query

Description	Sets or queries the EOF character for the UART packet setting.
-------------	--

Syntax	:BUS1:UART:EOFPacket <NR1>
--------	----------------------------

Parameter/Return parameter	<NR1>	0: NULL 1: LF (line feed) 2: CR (carriage return) 3: SP (space character) 4: FF
----------------------------	-------	---

Example :BUS1:UART:EOFPacket 2
Sets the OEF character to CR.

Set →

:BUS1:UART:TX:SOURce

→ Query

Description	Sets or queries which channel is used for the UART Tx source.
-------------	---

Syntax	:BUS1:UART:TX:SOURce { OFF CH1 CH2 CH3 CH4 D0 D1 D2 D3 D4 D5 D6 D7 D8 D9 D10 D11 D12 D13 D14 D15 ? }
--------	--

Parameter/Return parameter	OFF	Off, no Tx source
	CH1 to CH4	Analog channels CH1 to CH4
	D0 to D15	Digital channels D0 to D15

Example :BUS1:UART:TX:SOURce CH1
Sets channel 1 as the Tx source.

Set →
 → Query

:BUS1:UART:RX:SOURce

Description	Sets or queries which channel is used for the UART Rx source.	
Syntax	:BUS1:UART:RX:SOURce { OFF CH1 CH2 CH3 CH4 D0 D1 D2 D3 D4 D5 D6 D7 D8 D9 D10 D11 D12 D13 D14 D15 ? }	
Parameter/Return parameter	OFF	Off, no Rx source
	CH1 to CH4	Analog channels CH1 to CH4
	D0 to D15	Digital channels D0 to D15
Example	:BUS1:UART:RX:SOURce CH1 Sets channel 1 as the Rx source.	

Set →
 → Query

:BUS1:SPI:SCLK:POLARity

Description	Sets or queries the polarity of the SCLK line for the SPI bus.	
Syntax	:BUS1:SPI:SCLK:POLARity { FALL RISE ? }	
Parameter/Return parameter	FALL	Sets the polarity to falling edge.
	RISE	Sets the polarity to rising edge.
Example	:BUS1:SPI:SCLK:POLARity FALL Sets the polarity to falling edge.	

Set →
 → Query

:BUS1:SPI:SS:POLARity

Description	Sets or queries the polarity of the SS line for the SPI bus.	
Syntax	:BUS1:SPI:SS:POLARity { LOW HIGH ? }	
Parameter/Return parameter	LOW	Active low polarity
	HIGH	Active high polarity

Example :BUS1:SPI:SS:POLARity LOW
 Sets the SS line to active low.

Set →

→ Query

:BUS1:SPI:WORDSize

Description Sets the number of bits per word for the SPI bus.

Syntax :BUS1:SPI:WORDSize {<NR1> | ? }

Parameter/Return parameter <NR1> Bits per word (4–32)

Example :BUS1:SPI:WORDSize 4
 Sets the word size to 4 bits per word.

Set →

→ Query

:BUS1:SPI:BITORder

Description Sets or queries the bit order for the SPI bus.

Syntax :BUS1:SPI:BITORder {<NR1> | ? }

Parameter/Return parameter <NR1> 0: MSB bit first
 1: LSB bit first

Example :BUS1:SPI:BITORder?
 0
 The bit order is currently set as MSB bit first.

Set →

→ Query

:BUS1:SPI:SCLK:SOURce

Description Sets or queries which channel is used for the SPI SCLK source.

Syntax :BUS1:SPI:SCLK:SOURce { CH1 | CH2 | CH3 | CH4 | D0 | D1 | D2 | D3 | D4 | D5 | D6 | D7 | D8 | D9 | D10 | D11 | D12 | D13 | D14 | D15 | ? }

Parameter/Return parameter CH1 to CH4 Analog channels CH1 to CH4
 D0 to D15 Digital channels D0 to D15

Example :BUS1:SPI:SCLK:SOURce CH1
Sets channel 1 as the SPI SCLK source.

:BUS1:SPI:SS:SOURce  

Description Sets or queries which channel is used for the SPI SS source.

Syntax :BUS1:SPI:SS:SOURce { CH1 | CH2 | CH3 | CH4 | D0 | D1 | D2 | D3 | D4 | D5 | D6 | D7 | D8 | D9 | D10 | D11 | D12 | D13 | D14 | D15 | ? }

Parameter/Return parameter CH1 to CH4 Analog channels CH1 to CH4
D0 to D15 Digital channels D0 to D15

Example :BUS1:SPI:SS:SOURce CH1
Sets channel 1 as the SPI SS source.

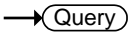
:BUS1:SPI:MOSI:SOURce  

Description Sets or queries which channel is used for the SPI MOSI source.

Syntax :BUS1:SPI:MOSI:SOURce { OFF | CH1 | CH2 | CH3 | CH4 | D0 | D1 | D2 | D3 | D4 | D5 | D6 | D7 | D8 | D9 | D10 | D11 | D12 | D13 | D14 | D15 | ? }

Parameter/Return parameter CH1 to CH4 Analog channels CH1 to CH4
D0 to D15 Digital channels D0 to D15
OFF No MOSI source.

Example :BUS1:SPI:MOSI:SOURce CH1
Sets channel 1 as the SPI MOSI source.

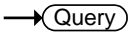
:BUS1:SPI:MISO:SOURce  

Description Sets or queries which channel is used for the SPI MISO source.

Syntax :BUS1:SPI:MISO:SOURce { OFF | CH1 | CH2 | CH3 | CH4 | D0 | D1 | D2 | D3 | D4 | D5 | D6 | D7 | D8 | D9 | D10 | D11 | D12 | D13 | D14 | D15 | ? }

Parameter/Return parameter	CH1 to CH4	Analog channels CH1 to CH4
	D0 to D15	Digital channels D0 to D15
	OFF	No MISO source.

Example :BUS1:SPI:MISO:SOURce CH1
Sets channel CH1 as the SPI MISO source.

Set →

:BUS1:DISplay:FORMAT

→ Query

Description Sets or queries the display format for the bus, either binary or hexadecimal.

Syntax :BUS1:DISplay:FORMAT { BINary | HEXadecimal | ASCII | ? }

Parameter/Return parameter	BINary	Binary format
	HEXadecimal	Hexadecimal format

Example : BUS1:DISplay:FORMAT BINary
Sets the display format to binary.

:LISTer:DATA

→ Query

Description Returns the Event Table data as a binary block data.

Syntax :LISTer:DATA?

Return Parameter Returns the event table as binary block data. The binary block data contains comma separated data with new lines at the end of each row.

:BUS1:CAN:SOURce (Set) →
→ (Query)

Description	Sets or returns the CAN input source.	
Syntax	:BUS1:CAN:SOURce { CH1 CH2 CH3 CH4 D0 D1 D2 D3 D4 D5 D6 D7 D8 D9 D10 D11 D12 D13 D14 D15 ? }	
Parameter/Return parameter	CH1 ~ CH4	Analog channel source
	D0 to D15	Digital channels D0 to D15
Example	:BUS1:CAN:SOURce? >CH1 Returns the CAN source.	

:BUS1:CAN:PROBe (Set) →
→ (Query)

Description	Sets or returns the signal type of the CAN bus.	
Syntax	:BUS1:CAN:PROBe {CANH CANL TX RX ? }	
Parameter/Return parameter	CANH	CAN-High
	CANL	CAN-Low
	TX	Transmit
	RX	Receive
Example	:BUS1:CAN:PROBe? >CANH :BUS1:CAN:PROBe CANL :BUS1:CAN:PROBe? >CANL	

:BUS1:CAN:SAMPLEpoint → (Query)

Description	Returns the sample point of the CAN bus.
Syntax	:BUS1:CAN:SAMPLEpoint?

Return Parameter Returns the sample point of the CAN bus as a percentage of the bit time.

Example :BUS1:CAN:SAMPLEpoint?
50

Returns the sample point as a percentage.

Set →

:BUS1:CAN:BITRate

→ Query

Description Sets or returns the bit rate of the CAN bus.

Syntax :BUS1:CAN:BITRate
{RATE10K|RATE20K|RATE50K|RATE125K|RATE250K|
RATE500K|RATE800K|RATE1M | <NR1> | ?}

Parameter/Return parameter	RATE10K	10 kbps
	RATE20K	20 kbps
	RATE50K	50 kbps
	RATE125K	125 kbps
	RATE250K	250 kbps
	RATE500K	500 kbps
	RATE800K	800 kbps
	RATE1M	1 Mbps
	<NR1>	CAN bit rate in bps

Example :BUS1:CAN:BITRate?
>1000000

:BUS1:CAN:BITRate rate800k
:BUS1:CAN:BITRate?
>800000

:BUS1:CAN:BITRate 25000
:BUS1:CAN:BITRate?
>25000

Set →
 → Query

:BUS1:LIN:BITRate

Description	Sets or returns the bit rate of the LIN bus.	
Syntax	:BUS1:LIN:BITRate {<NR1> ?}	
Parameter/Return parameter	<NR1>	LIN bit rate in bps.
Example	:BUS1:LIN:BITRate 9600 Sets the LIN bit rate to 9600bps.	

Set →
 → Query

:BUS1:LIN:IDFormat

Description	Sets or returns the LIN ID format.	
Syntax	:BUS1:LIN:IDFormat {NOPARity PARity ?}	
Parameter/Return parameter	NOPARity	Don't include parity bits with Id.
	PARity	Include parity bits with Id.
Example	:BUS1:LIN:IDFormat? NOPARITY Returns the ID format.	

Set →
 → Query

:BUS1:LIN:POLARity

Description	Sets or returns the LIN polarity.	
Syntax	:BUS1:LIN:POLARity {NORMAL INVerted ?}	
Parameter/Return parameter	NORMAL	Normal LIN polarity
	INVerted	Inverted LIN polarity
Example	:BUS1:LIN:POLARity? NORMAL Returns the LIN polarity.	

→ Query

:BUS1:LIN:SAMPLEpoint

Description	Returns the sample point.
Syntax	:BUS1:LIN:SAMPLEpoint?
Return Parameter	Returns the sample point of the LIN bus as a percentage.
Example	:BUS1:LIN:SAMPLEpoint? 50 Returns the sample point as a percentage.

Set →

→ Query

:BUS1:LIN:SOURce

Description	Sets or returns the LIN data source.
Syntax	:BUS1:LIN:SOURce {CH1 CH2 CH3 CH4 D0 D1 D2 D3 D4 D5 D6 D7 D8 D9 D10 D11 D12 D13 D14 D15 ? }
Parameter/Return parameter	CH1 ~ CH4 Analog channel source D0 to D15 Digital channels D0 to D15
Example	:BUS1:LIN:SOURCE? >CH1 Returns the LIN source.

Set →

→ Query

:BUS1:LIN:STANDard

Description	Sets or returns the LIN standard.
Syntax	:BUS1:LIN:STANDard {V1X V2X BOTH ?}
Parameter/Return parameter	V1X Lin standard version 1.x V2X Lin standard version 2.x BOTH Both standards
Example	:BUS1:LIN:STANDard? >BOTH Returns the LIN standard.

Mark Commands

:MARK	185
:MARK:CREATE.....	185
:MARK:DELEte	186

:MARK



Description	Move to next or previous event mark.	
Syntax	:MARK { NEXT PREvious }	
Related commands	:MARK:CREATE :MARK:DELEte	
Parameter	NEXT	Move to next mark
	PREvious	Move to previous mark
Example	:MARK NEXT Moves to the next event mark.	

:MARK:CREATE



Description	Creates a mark on the waveform at the current position or creates a mark for all the events for the current waveform.	
Syntax	:MARK:CREATE { CURREnt ALL }	
Related commands	:MARK :MARK:DELEte	
Parameter	CURREnt	Creates a mark at the current position
	ALL	Creates a mark for all the events.
Example	:MARK:CREATE CURREnt Creates a mark at the current position.	

:MARK:DELEte



Description	Deletes the current mark or all the marks on a waveform.	
Syntax	:MARK:DELEte { CURRent ALL }	
Related commands	:MARK :MARK:CREATE	
Parameter	CURRent	Deletes the current mark
	ALL	Deletes all the marks
Example	:MARK:DELEte CURRent Deletes the current mark.	

Search Commands

:SEARCH:COPIY	188
:SEARCH:STATE	189
:SEARCH:TOTAL.....	189
:SEARCH:TRIGger:TYPe	189
:SEARCH:TRIGger:SOURce.....	190
:SEARCH:TRIGger:EDGE:SLOP	190
:SEARCH:TRIGger:LEVel	191
:SEARCH:TRIGger:HLEVel	191
:SEARCH:TRIGger:LLEVel	192
:SEARCH:TRIGger:PULSEWidth:POLarity	192
:SEARCH:TRIGger:RUNT:POLarity	193
:SEARCH:TRIGger:RISEFall:SLOP.....	193
:SEARCH:TRIGger:PULSe:WHEn.....	194
:SEARCH:TRIGger:PULSe:TIMe.....	194
:SEARCH:TRIGger:RUNT:WHEn	195
:SEARCH:TRIGger:RUNT:TIMe.....	195
:SEARCH:TRIGger:RISEFall:WHEn	196
:SEARCH:TRIGger:RISEFall:TIMe	196
:SEARCH:TRIGger:BUS:TYPe	197
:SEARCH:TRIGger:BUS:B1:I2C:CONDition.....	197
:SEARCH:TRIGger:BUS:B1:I2C:ADDRes:MODE	198
:SEARCH:TRIGger:BUS:B1:I2C:ADDRes:TYPe	198
:SEARCH:TRIGger:BUS:B1:I2C:ADDRes:VALue	199
:SEARCH:TRIGger:BUS:B1:I2C:ADDRes:DIRection.....	200
:SEARCH:TRIGger:BUS:B1:I2C:DATA:SIZE.....	200
:SEARCH:TRIGger:BUS:B1:I2C:DATA:VALue.....	201
:SEARCH:TRIGger:BUS:B1:UART:CONDition.....	202
:SEARCH:TRIGger:BUS:B1:UART:RX:DATA:SIZE	203
:SEARCH:TRIGger:BUS:B1:UART:RX:DATA:VALue	203
:SEARCH:TRIGger:BUS:B1:UART:TX:DATA:SIZE	204
:SEARCH:TRIGger:BUS:B1:UART:TX:DATA:VALue	204
:SEARCH:TRIGger:BUS:B1:SPI:CONDition.....	205

:SEARCH:TRIGger:BUS:B1:SPI:DATA:SIZE.....206
 :SEARCH:TRIGger:BUS:B1:SPI:DATA:MISO:VALue.206
 :SEARCH:TRIGger:BUS:B1:SPI:DATA:MOSI:VALue.207
 :SEARCH:TRIGger:BUS:B1:CAN:CONDition208
 :SEARCH:TRIGger:BUS:B1:CAN:FRAMetype209
 SEARCH:TRIGger:BUS:B1:CAN:IDentifier:MODE ...209
 :SEARCH:TRIGger:BUS:B1:CAN:IDentifier:VALue...210
 :SEARCH:TRIGger:BUS:B1:CAN:IDentifier:DIRection210
 :SEARCH:TRIGger:BUS:B1:CAN:DATA:QUALifier ...211
 :SEARCH:TRIGger:BUS:B1:CAN:DATA:SIZE212
 :SEARCH:TRIGger:BUS:B1:CAN:DATA:VALue212
 :SEARCH:TRIGger:BUS:B1:LIN:CONDition213
 :SEARCH:TRIGger:BUS:B1:LIN:DATA:QUALifier214
 :SEARCH:TRIGger:BUS:B1:LIN:DATA:SIZE215
 :SEARCH:TRIGger:BUS:B1:LIN:DATA:VALue.....215
 :SEARCH:TRIGger:BUS:B1:LIN:ERRTYPE216
 :SEARCH:TRIGger:BUS:B1:LIN:IDentifier:VALue217
 :SEARCH:FFTPeak:METHod.....217
 :SEARCH:FFTPeak:METHod:MPEak218
 :SEARCH:FFTPeak:SINFo219

:SEARCH:COPY



Description	Copies the search settings to the trigger settings or copies the trigger settings to the search settings.	
Syntax	:SEARCH:COPY {SEARCHtotrigger TRIGgertosearch}	
Parameter	SEARCHtotrigger	Copy the search setting to the trigger settings.
	TRIGgertosearch	Copy the trigger settings to the search settings.
Example	:SEARCH:COPY SEARCHtotrigger Copies the search settings to the trigger settings.	

Set →
→ Query

:SEARCH:STATE

Description	Sets or queries whether the Search function is on or off.	
Syntax	:SEARCH:STATE { OFF ON ? }	
Parameter/Return parameter	OFF	Turn the Search function on.
	ON	Turn the Search function off.
Example	:SEARCH:STATE ON Turn Search on.	

→ Query

:SEARCH:TOTAL

Description	Returns the total number of events found from the search function.	
Syntax	:SEARCH:TOTAL?	
Return parameter	<NR1>	Number of events.
Example	:SEARCH:TOTAL? 5	

Set →
→ Query

:SEARCH:TRIGger:TYPE

Description	Sets or queries the search trigger type.	
Syntax	:SEARCH:TRIGger:TYPE { EDGe PULSEWidth RUNT RISEFall FFTPeak LOGic ? }	
Parameter/Return parameter	EDGe	Edge trigger
	PULSEWidth	Pulse width trigger
	RUNT	Runt trigger
	RISEFall	Rise and Fall trigger
	FFTPeak	FFT Peak trigger
	LOGic	Logic trigger

	BUS	Bus trigger
--	-----	-------------

Example :SEARCH:TRIGger:TYPe EDGE
Sets the search trigger to the edge type.

:SEARCH:TRIGger:SOURce (Set) →
→ (Query)

Description Sets or queries the search trigger source.

Syntax :SEARCH:TRIGger:SOURce {CH1 | CH2 | CH3 | CH4 | D0 | D1 | D2 | D3 | D4 | D5 | D6 | D7 | D8 | D9 | D10 | D11 | D12 | D13 | D14 | D15 | ? }

Parameter/Return parameter	CH1 to CH4	Channel 1 to Channel 4
	D0 to D15	Digital channels D0 to D15

Example :SEARCH:TRIGger:SOURce CH1
Sets the search trigger source as CH1.

:SEARCH:TRIGger:EDGE:SLOP (Set) →
→ (Query)

Description Sets or queries the search trigger slope.

Syntax :SEARCH:TRIGger:EDGE:SLOP { RISE | FALL | EITHER | ? }

Related commands :SEARCH:TRIGger:TYPe

Parameter	RISe	Rising slope
	FALL	Falling slope
	EITHer	Either rising or falling slope

Return parameter Returns the trigger slope.

Example :SEARCH:TRIGger:EDGE:SLOP FALL
Sets the search trigger slope to falling.

:SEARCH:TRIGger:LEVel  

Description	Sets or queries the search trigger level.	
Syntax	:SEARCH:TRIGger:LEVel {TTL ECL SETTO50 <NRf> ?}	
Related commands	:SEARCH:TRIGger:TYPe	
Parameter	<NRf>	Trigger level value
	TTL	Sets the search trigger level to TTL.
	ECL	Sets the search trigger level to ECL.
	SETTO50	Sets the search trigger level to the User level (50% by default).
Return parameter	<NR3>	Returns the trigger.
Example1	:SEARCH:TRIGger:LEVel TTL Sets the search trigger level to TTL.	
Example2	:SEARCH:TRIGger:LEVel 3.30E-1 Sets the search trigger level to 330mV/mA.	

:SEARCH:TRIGger:HLEVel  

Description	Sets or queries the high level search trigger.	
Note	Applicable for Rise and Fall/Pulse Runt search triggers.	
Syntax	:SEARCH:TRIGger:HLEVel { <NRf> ?}	
Related commands	:SEARCH:TRIGger:TYPe	
Parameter	<NRf>	High level value.
Return parameter	<NR3>	Returns the high level search trigger.
Example	:SEARCH:TRIGger:HLEVel 3.30E-1 Sets the high level search trigger to 330mV/mA.	

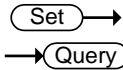

:SEARCH:TRIGger:LLEVel

Description	Sets or queries the low level search trigger.	
Note	Applicable for Rise and Fall/Pulse Runt triggers.	
Syntax	:SEARCH:TRIGger:LLEVel { <NRf> ?}	
Related commands	:SEARCH:TRIGger:TYPe	
Parameter	<NRf>	Low level value.
Return parameter	<NR3>	Returns the low level.
Example	:SEARCH:TRIGger:LLEVel -3.30E-3 Sets the low level search trigger to 330mV/mA.	

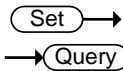

:SEARCH:TRIGger:PULSEWidth:POLarity

Description	Sets or queries the pulse width search trigger polarity.	
Syntax	:SEARCH:TRIGger:PULSEWidth:POLarity {POSitive NEGative ?}	
Related commands	:SEARCH:TRIGger:TYPe	
Parameter	POSitive	Positive polarity
	NEGative	Negative polarity
Return parameter	Returns the pulse width polarity.	
Example	:SEARCH:TRIGger:PULSEWidth:POLarity POSitive Sets the pulse width polarity to positive.	

Set →
→ Query

:SEARCH:TRIGger:RUNT:POLarity

Description	Sets or queries the Pulse Runt search trigger polarity.	
Syntax	:SEARCH:TRIGger:RUNT:POLarity {POSitive NEGative EITher ?}	
Related commands	:SEARCH:TRIGger:TYPE	
Parameter	POSitive	Positive polarity
	NEGative	Negative polarity
	EITher	Positive or negative polarity
Return parameter	Returns the pulse runt search trigger polarity.	
Example	:SEARCH:TRIGger:RUNT:POLarity POSitive Sets the Pulse Runt search trigger polarity to positive.	

Set →
→ Query

:SEARCH:TRIGger:RISEFall:SLOP

Description	Sets or queries the slope of the Rise and Fall search trigger.	
Syntax	:SEARCH:TRIGger:RISEFall:SLOP { RISE FALL EITher ? }	
Related commands	:SEARCH:TRIGger:TYPE	
Parameter	RISe	Rising slope
	FALL	Falling slope
	EITher	Either rising or falling slope
Return parameter	Returns the rise & fall slope.	
Example	:SEARCH:TRIGger:RISEFall :SLOP RISe Sets the Rise & Fall search trigger slope to rising.	

(Set) →
→ (Query)

:SEARCH:TRIGger:PULSe:WHEn

Description	Sets or queries the pulse width search trigger conditions.
Syntax	:SEARCH:TRIGger:PULSe:WHEn {MOREthan LESSthan EQual UNEQual ?}
Related commands	:SEARCH:TRIGger:TYPe :SEARCH:TRIGger:PULSe:TIMe
Parameter	MOREthan > LESSthan < EQual = UNEQual ≠
Return parameter	Returns the pulse width search trigger conditions.
Example	:SEARCH:TRIGger:PULSe:WHEn UNEQual Sets the pulse width search trigger conditions to not equal to (≠).



(Set) →
→ (Query)

:SEARCH:TRIGger:PULSe:TIMe

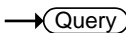
Description	Sets or queries the pulse width search trigger time.
Syntax	:SEARCH:TRIGger:PULSe:TIMe {<NRf> ?}
Related commands	:SEARCH:TRIGger:TYPe :SEARCH:TRIGger:PULSe:WHEn
Parameter	<NRf> Pulse width time (4ns~10s)
Return parameter	<NR3> Returns the pulse width time in seconds.
Example	:SEARCH:TRIGger:PULSe:TIMe 4.00E-5 Sets the pulse width search trigger to 40.0us.

:SEARCH:TRIGger:RUNT:WHEn



Description	Sets or queries the pulse runt search trigger conditions.								
Syntax	:SEARCH:TRIGger:RUNT:WHEn {MOREthan LESSthan EQual UNEQual ? }								
Related commands	:SEARCH:TRIGger:TYPE :SEARCH:TRIGger:RUNT:TIME								
Parameter	<table border="0"> <tr><td>MOREthan</td><td>></td></tr> <tr><td>LESSthan</td><td><</td></tr> <tr><td>Equal</td><td>=</td></tr> <tr><td>UNEQual</td><td>≠</td></tr> </table>	MOREthan	>	LESSthan	<	Equal	=	UNEQual	≠
MOREthan	>								
LESSthan	<								
Equal	=								
UNEQual	≠								
Return parameter	Returns the pulse runt search trigger conditions.								
Example	:SEARCH:TRIGger:RUNT:WHEn UNEQual Sets the pulse runt search trigger condition to unequal (≠).								

:SEARCH:TRIGger:RUNT:TIME



Description	Sets or queries the pulse runt search trigger time.
Syntax	:SEARCH:TRIGger:RUNT:TIME {<NRf> ? }
Related commands	:SEARCH:TRIGger:TYPE :SEARCH:TRIGger:RUNT:WHEn
Parameter	<NRf> Pulse runt time (4nS to 10S)
Return Parameter	<NR3> Returns the runt time in seconds.
Example	:SEARCH:TRIGger:RUNT:TIME 4.00E-5 Sets the pulse runt time to 40.0uS.

:SEARCH:TRIGger:RISEFall:WHEn (Set) →
→ (Query)

Description	Sets or queries the rise and fall search trigger conditions.
Syntax	:SEARCH:TRIGger:RISEFall:WHEn {MOREthan LESSthan EQual UNEQual ? }
Related commands	:SEARCH:TRIGger:TYPE :SEARCH:TRIGger:RISEFall:TIME
Parameter	MOREthan > LESSthan < Equal = UNEQual ≠
Return parameter	Returns the rise and fall search trigger condition.
Example	:SEARCH:TRIGger:RISEFall:WHEn UNEQual Sets the rise and fall search trigger condition to unequal (≠).

:SEARCH:TRIGger:RISEFall:TIME (Set) →
→ (Query)

Description	Sets or queries the rise and fall time.
Syntax	:SEARCH:TRIGger:RISEFall:TIME {<NRf> ? }
Related commands	:SEARCH:TRIGger:TYPE :SEARCH:TRIGger:RISEFall:WHEn
Parameter	<NRf> Rise and Fall time (4nS to 10S)
Return Parameter	<NR3> Returns the rise and fall time in seconds.
Example	:SEARCH:TRIGger:RISEFall:TIME 4.00E-5 Sets the trigger rise and fall time to 40.0us.

:SEARCH:TRIGger:BUS:TYPE → Query

Description	Returns the current bus type.	
Syntax	:SEARCH:TRIGger:BUS:TYPE?	
Return parameter	I2C	I2C mode
	SPI	SPI mode
	UART	UART mode
	CAN	CAN mode
	LIN	LIN mode
	PARAllel	Parallel mode
Example	:SEARCH:TRIGger:BUS:TYPE? UART	

:SEARCH:TRIGger:BUS:B1:I2C:CONDition Set →
→ Query

Description	Sets or queries the I ² C search trigger conditions.	
Syntax	:SEARCH:TRIGger:BUS:B1:I2C:CONDition {START STOP REPEATstart ACKMISS ADDRess DATA ADDRANDDATA ? }	
Parameter	START	Set Start as the I ² C search trigger condition.
	STOP	Set Stop as the I ² C search trigger condition.
	REPEATstart	Set Repeat of Start as the I ² C search trigger condition.
	ACKMISS	Set Missing Acknowledgement as the I ² C search trigger condition.
	ADDRess	Set Address as the I ² C search trigger condition.

DATA	Set Data as the I ² C search trigger condition.
ADDRANDDATA	Set Address and Data as the I ² C search trigger condition.

Return parameter Returns the I²C bus search trigger condition.

Example :SEARCH:TRIGger:BUS:B1:I2C:CONDition ADDRess
Set Address as the I²C search trigger condition.

:SEARCH:TRIGger:BUS:B1:I2C:ADDRess (Set) →
:MODE → (Query)

Description Sets or queries the I²C addressing mode (7 or 10 bits) for the search trigger.

Syntax :SEARCH:TRIGger:BUS:B1:I2C:ADDRess:MODE
{ADDR7 | ADDR10 | ? }

Related commands :SEARCH:TRIGger:BUS:B1:I2C:CONDition

Parameter	ADDR7	7 bit addressing
	ADDR10	10 bit addressing

Return Parameter	0	7 bit addressing
	1	10 bit addressing

Example :SEARCH:TRIGger:BUS:B1:I2C:ADDRess:MODE?
0
The addressing mode is current set to 7 bits.

:SEARCH:TRIGger:BUS:B1:I2C:ADDRess (Set) →
:TYPE → (Query)

Description Sets the I²C bus address type, or queries what the setting is for the search trigger.

Syntax :SEARCH:TRIGger:BUS:B1:I2C:ADDRess:TYPE
{GENeralcall | STARtbyte | HSmode | EEPROM | CBUS
| ?}

Related commands	:SEARCH:TRIGger:BUS:B1:I2C:CONDition	
Parameter	GENeralcall	Set a general call address (0000 000 0).
	STARtbyte	Set a start byte address. (0000 000 1)
	HSmode	Set a high-speed mode address. (0000 1xx x)
	EEPROM	Set an EEPROM address. (1010 xxx x)
	CBUS	Set a CBUS address. (0000 001 x)
Return Parameter	Returns the address type	
Example	:SEARCH:TRIGger:BUS:B1:I2C:ADDRes:TYPE? CBUS	

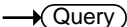
:SEARCH:TRIGger:BUS:B1:I2C:ADDRes : 
:VALue 



Description	Sets or queries the I ² C bus address value when the I ² C search trigger is set to trigger on Address or Address/Data.	
Syntax	:SEARCH:TRIGger:BUS:B1:I2C:ADDRes:VALue {<string> ? }	
Related commands	:SEARCH:TRIGger:BUS:B1:I2C:ADDRes:MODE	
Parameter	<sting>	7/10 characters, must be enclosed in double quotes "string". x = don't care 1 = binary 1 0 = binary 0
Return Parameter	Returns the address value in binary.	

Note	This setting only applies when the I ² C search trigger is set to trigger on Data or Address/Data	
Syntax	:SEARCH:TRIGger:BUS:B1:I2C:DATA:SIZE {<NR1> ? }	
Related commands	:SEARCH:TRIGger:BUS:B1:I2C:CONDition	
Parameter	<NR1>	Number of data bytes (1 to 5).
Return parameter	<NR1>	Returns the number of bytes.
Example	:SEARCH:TRIGger:BUS:B1:I2C:DATA:SIZE 3 Sets the number of bytes to 3.	



Set →

:SEARCH:TRIGger:BUS:B1:I2C:DATA:VALue → Query

Description	Sets or queries the triggering data value for the I ² C bus when the I ² C search trigger is set to trigger on Data or Address/Data.	
Syntax	:SEARCH:TRIGger:BUS:B1:I2C:DATA:VALue {<string> ? }	
Related commands	:SEARCH:TRIGger:BUS:B1:I2C:DATA:SIZE	
Parameter	<string>	The number of characters in the string depends on the data size setting. The string must be enclosed in double quotes, "string". x = don't care 1 = binary 1 0 = binary 0
Return Parameter	Returns the data value.	
Example 1	:SEARCH:TRIGger:BUS:B1:I2C:DATA:SIZE 1 :SEARCH:TRIGger:BUS:B1:I2C:DATA:VALue "1x1x0101" Sets the value to XXX0101	

:SEARCH:TRIGger:BUS:B1:UART:RX:DATA:SIZE  →
 →

Description	Sets or queries the number of bytes for UART data.	
Note	This setting only applies when the UART search trigger is set to trigger on Rx Data	
Syntax	:SEARCH:TRIGger:BUS:B1:UART:RX:DATA:SIZE {<NR1> ?}	
Related commands	:SEARCH:TRIGger:BUS:B1:UART:CONDition	
Parameter	<NR1>	Number of bytes (1 to 10).
Return parameter	<NR1>	Returns the number of bytes.
Example	:SEARCH:TRIGger:BUS:B1:UART:RX:DATA:SIZE 5 Sets the number of bytes to 5.	

:SEARCH:TRIGger:BUS:B1:UART:RX:DATA:VALue  →
 →

Description	Sets or queries the search triggering data value for the UART bus when the bus is set to trigger on Rx Data.	
Syntax	:SEARCH:TRIGger:BUS:B1:UART:RX:DATA:VALue {<string> ?}	
Related commands	:SEARCH:TRIGger:BUS:B1:UART:RX:DATA:SIZE	
Parameter	<string>	The number of characters in the string depends on the data size setting. The string must be enclosed in double quotes, "string". x = don't care 1 = binary 1 0 = binary 0

Return Parameter Returns the data value.

Example 1 :SEARCH:TRIGger:BUS:B1:UART:CONDition RXDATA
 :SEARCH:TRIGger:BUS:B1:UART:RX:DATA:SIZE 1
 :SEARCH:TRIGger:BUS:B1:UART:RX:DATA:VALue
 "1x1x0101"
 Sets the value to 1x1x0101

Example 2 :SEARCH:TRIGger:BUS:B1:UART:RX:DATA:VALue?
 1X1X0101

:SEARCH:TRIGger:BUS:B1:UART:TX:DATA (Set) →
 :SIZE → (Query)

Description Sets or queries the number of bytes for UART data.

Note This setting only applies when the UART search trigger is set to trigger on Tx Data

Syntax :SEARCH:TRIGger:BUS:B1:UART:TX:DATA:SIZE
 {<NR1> | ?}

Related commands :SEARCH:TRIGger:BUS:B1:UART:CONDition

Parameter <NR1> Number of bytes (1 to 10).

Return parameter <NR1> Returns the number of bytes.

Example :SEARCH:TRIGger:BUS:B1:UART:TX:DATA:SIZE 5
 Sets the number of bytes to 5.

:SEARCH:TRIGger:BUS:B1:UART:TX:DATA:VALue (Set) →
 VALue → (Query)

Description Sets or queries the search triggering data value for the UART bus when the bus is set to trigger on Tx Data.

Syntax :SEARCH:TRIGger:BUS:B1:UART:TX:DATA:VALue
 {<string> | ?}

Related commands :SEARCH:TRIGger:BUS:B1:UART:TX:DATA:SIZE

Parameter	<code><string></code>	The number of characters in the string depends on the data size setting. The string must be enclosed in double quotes, "string". x = don't care 1 = binary 1 0 = binary 0
-----------	-----------------------------	--

Return Parameter Returns the data value.

Example 1 :SEARCH:TRIGger:BUS:B1:UART:CONDition TXDATA
 :SEARCH:TRIGger:BUS:B1:UART:TX:DATA:SIZE 1
 :SEARCH:TRIGger:BUS:B1:UART:TX:DATA:VALue "1x1x0101"
 Sets the value to 1x1x0101

Example 2 :SEARCH:TRIGger:BUS:B1:UART:TX:DATA:VALue?
 1X1X0101

Set →

→ Query

:SEARCH:TRIGger:BUS:B1:SPI:CONDition

Description Sets or queries the SPI search triggering condition.

Syntax :SEARCH:TRIGger:BUS:B1:SPI:CONDition {SS | MISO | MOSI | MISOMOSI | ? }

Parameter	SS	Set to trigger on the Slave Selection condition.
	MISO	Set to trigger on the Master-In Slave-Out condition.
	MOSI	Set to trigger on the Master-Out Slave-In condition.
	MISOMOSI	Set to trigger on the Master-In Slave-Out and Master-Out Slave-In conditions.

Return Parameter Returns the triggering condition.

Example :SEARCH:TRIGger:BUS:B1:SPI:CONDition MISO
Sets the SPI bus to trigger on MISO.

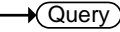
:SEARCH:TRIGger:BUS:B1:SPI:DATA:SIZE  

Description Sets or queries the number of words for SPI data for the search function.

Note This setting only applies when the SPI search trigger is set to trigger on MISO, MOSI or MISO/MOSI

Syntax :SEARCH:TRIGger:BUS:B1:SPI:DATA:SIZE {<NR1> | ?}

Related commands :SEARCH:TRIGger:BUS:B1:SPI:CONDition

Parameter <NR1> Number of words (1 to 32).

Return parameter <NR1> Returns the number of words.

Example :SEARCH:TRIGger:BUS:B1:SPI:DATA:SIZE 10
Sets the number of words to 10.

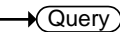
:SEARCH:TRIGger:BUS:B1:SPI:DATA:MISO:  

Description Sets or queries the search triggering data value for the SPI bus when the bus is set to trigger on MISO or MISO/MOSI.

Syntax :SEARCH:TRIGger:BUS:B1:SPI:DATA:MISO:VALue {<string> | ?}

Related commands :SEARCH:TRIGger:BUS:B1:SPI:DATA:SIZE

Parameter <string> The number of characters in the string depends on the data size setting. The string must be enclosed in double quotes, "string".

Example1 :SEARCH:TRIGger:BUS:B1:SPI:CONDition MOSI
 :SEARCH:TRIGger:BUS:B1:SPI:DATA:SIZE 2
 :SEARCH:TRIGger:BUS:B1:SPI:DATA:MOSI:VALue
 "1x1x0101"
 Sets the value to 1x1x0101

Example2 :SEARCH:TRIGger:BUS:B1:SPI:DATA:MOSI:VALue?
 1X1X0101

Set →

:SEARCH:TRIGger:BUS:B1:CAN:CONDition → Query

Description Sets or returns the CAN search trigger condition.

Syntax :SEARCH:TRIGger:BUS:B1:CAN:CONDition
 {SOF|FRAMEtype|IDentifier|DATA|IDANDDATA|EOF|
 ACKMISS|STUFFERR|?}

Parameter/ Return parameter	SOF	Sets search to trigger on a start of frame
	FRAMEtype	Sets search to trigger on the type of frame
	IDentifier	Sets search to trigger on a matching identifier
	DATA	Sets search to trigger on matching data
	IDANDDATA	Sets search to trigger on matching identifier and data field
	EOF	Sets search to trigger on the end of frame
	ACKMISS	Sets search to trigger on a missing acknowledge
	STUFFERR	Sets search to trigger on a bit stuffing error

Example1 :SEARCH:TRIGger:BUS:B1:CAN:CONDition SOF
 Triggers search on a start of frame.

Example2 :SEARCH:TRIGger:BUS:B1:CAN:CONDition?
>SOF

Set →

:SEARCH:TRIGger:BUS:B1:CAN:FRAMeType → Query

Description Sets or returns the frame type for the CAN FRAMeType search trigger.

Syntax :SEARCH:TRIGger:BUS:B1:CAN:FRAMeType
{DATA|REMOte|ERRor|OVERLoad|?}

Parameter/ Return parameter	DATA	Sets the frame type to data frame
	REMOte	Sets the frame type to remote frame
	ERRor	Sets the frame type to error frame
	OVERLoad	Sets the frame type to overload

Example :SEARCH:TRIGger:BUS:B1:CAN:FRAMeType DATA
Sets the frame type to DATA.

SEARCH:TRIGger:BUS:B1:CAN:IDentifier:
MODE

Set →

→ Query

Description Sets or returns the CAN identifier mode for the bus.

Syntax :SEARCH:TRIGger:BUS:B1:CAN:IDentifier:MODE
{STANDard|EXTended|?}

Parameter/ Return parameter	STANDard	Standard addressing mode
	EXTended	Extended addressing mode

Example :SEARCH:TRIGger:BUS:B1:CAN:IDentifier:MODE?
>STANDARD

:SEARCH:TRIGger:BUS:B1:CAN:IDentifier:MODE
EXTENDED

:SEARCH:TRIGger:BUS:B1:CAN:IDentifier:MODE?
>EXTENDED

:SEARCH:TRIGger:BUS:B1:CAN:IDentifier: VALue (Set) →
→ (Query)

Description	Sets or returns the identifier string used for the CAN search trigger. Note: Only applicable when the search trigger condition is set to ID or IDANDDATA.	
Syntax	:SEARCH:TRIGger:BUS:B1:CAN:IDentifier:VALue {<string> ?}	
Related Commands	:SEARCH:TRIGger:BUS:B1:CAN:IDentifier:MODE	
Parameter/ Return parameter	<string>	The size of the string depends on the data size setting. The string must be enclosed in double quotes, "string". String contents: x = don't care 1 = binary 1 0 = binary 0

Example

```
:SEARCH:TRIGger:BUS:B1:CAN:CONDition ID
:SEARCH:TRIGger:BUS:B1:CAN:IDentifier:MODE
STANDARD
:SEARCH:TRIGger:BUS:B1:CAN:IDentifier:VALue
"01100X1X01X"
:SEARCH:TRIGger:BUS:B1:CAN:IDentifier:VALue?
>01100X1X01X
```

:SEARCH:TRIGger:BUS:B1:CAN:IDentifier :DIRection (Set) →
→ (Query)

Description	Sets or queries the address bit as read, write or don't care.	
Syntax	:SEARCH:TRIGger:BUS:B1:CAN:IDentifier:DIRection {READ WRITE NOCARE ?}	

Parameter/ Return parameter	READ	Sets read as the data direction
	WRITE	Sets write as the data direction
	NO CARE	Sets either as the data direction

Example2 :SEARCH:TRIGger:BUS:B1:CAN:IDentifier:DIRection?
>WRITE

:SEARCH:TRIGger:BUS:B1:CAN:IDentifier:DIRection
READ

:SEARCH:TRIGger:BUS:B1:CAN:IDentifier:DIRection?
>READ

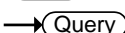
:SEARCH:TRIGger:BUS:B1:CAN:DATA: 
QUALifier 

Description Sets or returns the CAN data qualifier.
Note: Only applicable when the search triggering condition is set to DATA or IDANDDATA.

Syntax :SEARCH:TRIGger:BUS:B1:CAN:DATA:QUALifier
{LESSthan|MOREthan|EQual|UNEQual|LESSEQual|M
OREEQual|?}

Parameter/ Return parameter	LESSthan	Sets search to trigger when the data is less than the qualifier value.
	MOREthan	Sets search to trigger when the data is greater than the qualifier value.
	EQual	Sets search to trigger when the data is equal to the qualifier value.
	UNEQual	Sets search to trigger when the data is not equal to the qualifier value.
	LESSEQual	Sets search to trigger when the data is less than or equal to the qualifier value.
	MOREEQual	Sets search to trigger when the data is more than or equal to the qualifier value.

Example :SEARCH:TRIGger:BUS:B1:CAN:DATA:QUALifier?
 >EQUAL
 :SEARCH:TRIGger:BUS:B1:CAN:DATA:QUALifier
 MOREthan
 :SEARCH:TRIGger:BUS:B1:CAN:DATA:QUALifier?
 >MORETHAN

Set →

:SEARCH:TRIGger:BUS:B1:CAN:DATA:SIZE → Query

Description Sets or returns the length of the data string in bytes for the CAN search trigger.
 Note: Only applicable when the condition is set to DATA or IDANDDATA.

Syntax :SEARCH:TRIGger:BUS:B1:CAN:DATA:SIZE {<NR1>|?}

Parameter/ Return parameter <NR1> 1~8 (bytes)

Example :SEARCH:TRIGger:BUS:B1:CAN:DATA:SIZE?
 >1
 :SEARCH:TRIGger:BUS:B1:CAN:DATA:SIZE 2
 :SEARCH:TRIGger:BUS:B1:CAN:DATA:SIZE?
 >2

:SEARCH:TRIGger:BUS:B1:CAN:DATA: VALue Set →
 → Query

Description Sets or returns the binary data string to be used for the CAN search trigger.

Related Commands :SEARCH:TRIGger:BUS:B1:CAN:DATA:SIZE

Syntax :SEARCH:TRIGger:BUS:B1:CAN:DATA:VALue {<string>|?}

Parameter/ Return parameter <string> The size of the string depends on the data size setting. The string must be enclosed in double quotes, "string".

String contents:

x = don't care

1 = binary 1

0 = binary 0

Example :SEARCH:TRIGger:BUS:B1:CAN:DATA:SIZE 1
 :SEARCH:TRIGger:BUS:B1:CAN:DATA:VALue
 "01010X1X"
 :SEARCH:TRIGger:BUS:B1:CAN:DATA:VALue?
 >01010X1X

Set →

:SEARCH:TRIGger:BUS:B1:LIN:CONDition → Query

Description Sets or returns the LIN search trigger condition.

Syntax :SEARCH:TRIGger:BUS:B1:LIN:CONDition
 {SYNCField|IDentifier|DATA|IDANDDATA|WAKEup|SLEEPEP|ERRor{?}}

Parameter/ Return parameter	SYNCField	Sets the LIN search trigger condition to the sync field.
	IDentifier	Sets the LIN search trigger condition to identifier field.
	DATA	Sets the LIN search trigger condition to the data field.
	IDANDDATA	Sets the LIN search trigger condition to identifier and data field
	WAKEup	Sets the LIN search trigger condition to wake up.
	SLEEP	Sets the LIN search trigger condition to sleep.
	ERRor	Sets the LIN search trigger condition to error.

```
Example :SEARCH:TRIGger:BUS:B1:LIN:CONDition?
>IDANDDATA

:SEARCH:TRIGger:BUS:B1:LIN:CONDition DATA

:SEARCH:TRIGger:BUS:B1:LIN:CONDition?
>DATA
```

```
:SEARCH:TRIGger:BUS:B1:LIN:DATA:
QUALifier
```

Description	Sets or returns the LIN data qualifier. Note: Only applicable when the search trigger condition is set to DATA or IDANDDATA.	
Syntax	:SEARCH:TRIGger:BUS:B1:LIN:DATA:QUALifier {LESSthan MOREthan Equal UNEQual LESSEQual MOREEQual ?}	
Parameter/ Return parameter	LESSthan	Sets search to trigger when the data is less than the qualifier value.
	MOREthan	Sets search to trigger when the data is greater than the qualifier value.
	Equal	Sets search to trigger when the data is equal to the qualifier value.
	UNEQual	Sets search to trigger when the data is not equal to the qualifier value.
	LESSEQual	Sets search to trigger when the data is less than or equal to the qualifier value.
	MOREEQual	Sets search to trigger when the data is more than or equal to the qualifier value.

Example :SEARCH:TRIGger:BUS:B1:LIN:DATA:QUALifier?
 >EQUAL
 :SEARCH:TRIGger:BUS:B1:LIN:DATA:QUALifier
 MOREthan
 :SEARCH:TRIGger:BUS:B1:LIN:DATA:QUALifier?
 >MORETHAN

Set →
 → Query

Description Sets or returns the length of the data string in bytes for the LIN search trigger.
 Note: Only applicable when the condition is set to DATA or IDANDDATA.

Syntax :SEARCH:TRIGger:BUS:B1:LIN:DATA:SIZE {<NR1>|?}

Parameter/ Return parameter	<NR1>	1~8 (bytes)
--------------------------------	-------	-------------

Example :SEARCH:TRIGger:BUS:B1:LIN:DATA:SIZE?
 >1
 :SEARCH:TRIGger:BUS:B1:LIN:DATA:SIZE 2
 :SEARCH:TRIGger:BUS:B1:LIN:DATA:SIZE?
 >2

Set →
 → Query

Description Sets or returns the binary data string to be used for the LIN search trigger.
 Note: Only applicable when the condition is set to DATA or IDANDDATA.

Related Commands :SEARCH:TRIGger:BUS:B1:LIN:DATA:SIZE

Syntax :SEARCH:TRIGger:BUS:B1:LIN:DATA:VALue
 {<string>|?}

Parameter/ Return parameter	<string>	The size of the string depends on the data size setting. The string must be enclosed in double quotes, "string". String contents: x = don't care 1 = binary 1 0 = binary 0
--------------------------------	----------	--

Example

```
:SEARCH:TRIGger:BUS:B1:LIN:DATA:SIZE 1
:SEARCH:TRIGger:BUS:B1:LIN:DATA:VALue
"01010X1X"
:SEARCH:TRIGger:BUS:B1:LIN:DATA:VALue?
>01010X1X
```

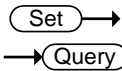

:SEARCH:TRIGger:BUS:B1:LIN:ERRTYPE

Description	Sets or returns the error type to be used for the LIN search trigger.	
Syntax	:SEARCH:TRIGger:BUS:B1:LIN:ERRTYPE {SYNC PARity Checksum ?}	
Parameter/ Return parameter	SYNC	Sets the LIN error type to SYNC.
	PARity	Sets the LIN error type to parity.
	Checksum	Sets the LIN error type to checksum.

Example

```
:SEARCH:TRIGger:BUS:B1:LIN:ERRTYPE?
>SYNC
:SEARCH:TRIGger:BUS:B1:LIN:ERRTYPE CHECKSUM
:SEARCH:TRIGger:BUS:B1:LIN:ERRTYPE?
>CHECKSUM
```

:SEARCH:TRIGger:BUS:B1:LIN:IDentifier: VALue (Set) →
→ (Query)

Description Sets or returns the identifier string to be used for the LIN search trigger.
Note: Only applicable when the condition is set to ID or IDANDDATA.

Syntax :SEARCH:TRIGger:BUS:B1:LIN:IDentifier:VALue {<string>|?}

Parameter/ Return parameter	<string>	The size of the string depends on the data size setting. The string must be enclosed in double quotes, "string". String contents: x = don't care 1 = binary 1 0 = binary 0
--	-----------------------	--

Example :SEARCH:TRIGger:BUS:B1:LIN:CONDition ID
:SEARCH:TRIGger:BUS:B1:LIN:IDentifier:VALue "00X1X01X"
:SEARCH:TRIGger:BUS:B1:LIN:IDentifier:VALue? >01100X1X01X

:SEARCH:FFTPeak:METHOD (Set) →
→ (Query)

Description Sets or returns the FFT peak method type.

Related Commands :SEARCH:TRIGger:TYPE
:SEARCH:FFTPeak:METHOD:MPEak
:SEARCH:TRIGger:LEVel

Syntax :SEARCH:FFTPeak:METHOD {MPEak | LEVel | ?}

Parameter/ Return parameter	MPEak	Sets the peak method to the Max Peak type.
	LEVEL	Sets the peak methods to the Level type.

Example

```
:SEARCH:FFTPeak:METHOD LEVEL
:SEARCH:FFTPeak:METHOD?
>LEVEL
:SEARCH:TRIGger:LEVEL?
>1.000E+00
:SEARCH:TRIGger:LEVEL 2
:SEARCH:TRIGger:LEVEL?
>2.000E+00
```

:SEARCH:FFTPeak:METHOD:MPEak



Description	Sets the active peak number (1 ~ 10) or return the frequency of the active peak number.	
Related Commands	:SEARCH:TRIGger:TYPE :SEARCH:FFTPeak:METHOD	
Syntax	:SEARCH:FFTPeak:METHOD:MPEak {<NR1> ?}	
Parameter	<NR1>	Active peak number.
Return parameter	<NR3>	Frequency of the active peak.

Example

```
:SEARCH:FFTPeak:METHOD MPEak
:SEARCH:FFTPeak:METHOD?
>MPEAK
:SEARCH:FFTPeak:METHOD:MPEak?
>1.000E+00
:SEARCH:FFTPeak:METHOD:MPEak 2
:SEARCH:FFTPeak:METHOD:MPEak?
>2.000E+00
```

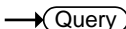
		
		
:SEARCH:FFTPeak:SINFo		
Description	Sets or returns the State Info to “Mark” or “Peak”.	
Related Commands	:SEARCH:TRIGger:TYPe	
Syntax	:SEARCH:FFTPeak:SINFo {MARK PEAK ?}	
Parameter/ Return parameter	MARK	Sets the State Info to Mark.
	PEAK	Sets the State Info to Peak.
Example	<pre> :SEARCH:FFTPeak:SINFo? >PEAK :SEARCH:FFTPeak:SINFo mark :SEARCH:FFTPeak:SINFo? >MARK </pre>	

Digital Commands

:D<x>:DISPlay	220
:D<x>:POSition	220
:DISPlay:DIGital:HEIght	221
:DIGital:GROU<x>:THReshold	221
:DIGital:ANALog:A<x>:DISPlay	222
:DIGital:ANALog:A<x>:RATio	223
:DIGital:ANALog:A<x>:POSition	223
:D<x>:MEMory	223
:DIGital:MEMory	225

:D<x>:DISPlay (Set) →
→ (Query)

Description	Turns a digital channel <x> on/off or returns its status.	
Syntax	:D<x>:DISPlay {OFF ON ?}	
Parameter / Return parameter	OFF	Turns off a digital channel
	ON	Turns on a digital channel
	D<x>	Digital channel number D0 ~ D15
Example	:D0:DISP OFF	

:D<x>:POSition (Set) →
→ (Query)

Description	Sets or returns the position level for digital channel <x>.	
Syntax	:D<x>:POSition {<NRf> ?}	
Parameter / Return parameter	D<x>	Digital channel number D0 ~ D15
	<NRf>	Vertical scale position

Example :D0:POS ?
 >1.87 DIV
 :D0:POS 0

Set →

→ Query

:DISPlay:DIGital:HEIght

Description Sets or returns the number of available digital waveform position slots.

Syntax :DISPlay:DIGital:HEIght {SMALL | MEDium | LARge | ?}

Parameter / Return parameter	SMALL	Sets the height to small mode (digital channels: 16 max)
	MEDium	Sets the height to medium mode (digital channels: 16 max)
	LARge	Sets the height to large mode (digital channels: 8 max)

Example :DIS:DIG:HEI ?
 >LARGE
 :DIS:DIG:HEI SMA

Set →

→ Query

:DIGital:GROUP<x>:THReshold

Description Sets or returns the digital threshold for a group.

Syntax :DIGital:GROUP<x> {ECL | TTL | PECL | CMOS5 | CMOS3 | CMOS2 | <NR3> | ?}

Parameter / Return parameter	ECL	Sets the threshold to a preset ECL high level (-1.3V)
	TTL	Sets the threshold to a preset TTL high level (1.4V)
	PECL	Sets the threshold to a preset PECL high level (3.7V)
	CMOS5	Sets the threshold to a preset CMOS5 (5.0V) high level (2.5V)
	CMOS3	Sets the threshold to a preset CMOS3 (3.3V) high level (1.65V)
	CMOS2	Sets the threshold to a preset CMOS2 (2.5V) high level (1.25V)
	<NR3>	Sets the threshold to a preset ECL high level (-1.3V)
	GROUP<x>	Group number 1~4 (16 channels) or 1~2 (8 channels) GROUP1: digital channels D0~D3 GROUP2: digital channels D4~D7 GROUP3: digital channels D8~D11 GROUP4: digital channels D12~D15

Example :DIG:GROUP1:THR ?
>-1.300e+00
:DIG:GROUP1:THR TTL

:DIGital:ANALog:A<x>:DISPlay



Description	Turns the analog waveform <x> on/off or returns its status.	
Syntax	:DIGital:ANALog:A<x>:DISPlay {OFF ON ?}	
Parameter / Return parameter	OFF	Turns off the analog waveform
	ON	Turns on the analog waveform
	A<x>	Analog waveform number 1~2

Example :DIG:ANA:A1:DISP OFF

:DIGital:ANALog:A<x>:RATio (Set) →
→ (Query)

Description Sets or returns the analog waveform vertical scale ratio.

Syntax :DIGital:ANALog:A<x>:RATio {<NRf> | ?}

Parameter / Return parameter	<NRf>	Vertical scale ratio (0.1, 0.2, ...1).
	A<x>	Analog waveform number 1~2

Example :DIG:ANA:A1:RAT 0.1

:DIGital:ANALog:A<x>:POSition (Set) →
→ (Query)

Description Sets or returns the analog waveform vertical scale position.

Syntax :DIGital:ANALog:A<x>:POSition {<NRf> | ?}

Parameter / Return parameter	<NRf>	Vertical scale position (0, 0.1, 0.2, ...8).
	A<x>	Analog waveform number 1~2

Example :DIG:ANA:A1:POS 4.5

:D<x>:MEMory → (Query)

Description Returns the data in acquisition memory for the selected digital channel.

Syntax :D<x>:MEMory?

Related commands :ACquire:RECOrdlength
:HEADer

Parameter	D<x>	Digital channel number D0 ~ D15
Return parameter		Returns acquisition settings followed by raw waveform block data.
	<string>	<p><string></p> <p>Returns the acquisition settings for the selected digital channel.</p> <p>Format: parameter(1),setting(1);parameter(2),setting(2)...parameter(n),setting(n);Waveform Data;</p>
	<waveform block data>	<p><waveform block data></p> <p>Header followed by the raw waveform data.</p> <p>Format: Header: The header (in ASCII) encodes the number of bytes for the header followed by the number of data points in bytes for the raw data.</p> <div style="text-align: right; margin-right: 100px;"> <p>ASCII #520000</p> </div> <p>Raw Data: Each two bytes (in hex) encodes the logical level (0 or 1) of a data point of the digital channel, i.e. logical 0 is 0x0000 and logical 1 is 0x0001.</p>

Waveform Raw Data Example:
 Header raw data.....
 Hex:
 35 32 30 30 30 30 30 30 00 00 00 00 00 00
 00 01 00 01
 ASCII/Decimal:
 #520000 0000000101
 The raw data contains 20000 bytes
 (=10000 points); point 1 is logical 0,
 point 2 is logical 0, point 3 is logical 0,
 point 4 is logical 1, point 5 is logical 1,
 etc...

Example :D1:MEM?
 FORMAT,2.0A;Display,1;Memory
 Length,10000;IntpDistance,0; Trigger Address,0;
 Threshold Used,1.400E+00;Source,D1;Vertical
 Units,V; Label1,;Firmware,V1.25b10; Horizontal
 Units,S;Horizontal Scale,1.000E-04; Horizontal
 Position,0.000E+00;Horizontal Mode,Main;SincET
 Mode,Real Time; Sampling Period,1.000E-07;Time,22-
 Sep-16 19:42:28;
 Waveform Data;
 #520000.....follows waveform block
 data.....

:DIGital:MEMory → Query

Description Returns the data in acquisition memory for all the digital channels.

Syntax :DIGital:MEMory?

Related commands :ACQuire:RECOrdlength
 :HEADer

bit is channel 0 and the most significant bit is channel 15.

Waveform Raw Data Example:

Header raw data.....

Hex:

35 32 30 30 30 30 30 00 15 00 14 00 11
00 10

ASCII/Decimal:

#520000 raw data

The raw data contains 20000 bytes (=10000 points) with the following logical level for each channels per data point:

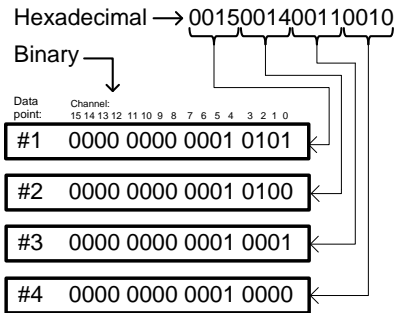

Example

```
:DIG:MEM?
Format,2.0E;Display,1111111111111111;Memory
Length,10000;IntpDistance,0;Trigger
Address,0;Threshold12_15,1.40V;Threshold8_11,1.40V
;Threshold4_7,1.40V;Threshold0_3,1.40V;Vertical
Units,V;Label15,;Label14,;Label13,;Label12,;Label11,;L
abel10,;Label9,;Label8,;Label7,;Label6,;Label5,;Label4,;
Label3,;Label2,;Label1,;Label0,;Firmware,V1.25b10;Ho
rizontal Units,S;Horizontal Scale,1.000E-04;Horizontal
Position,0.000E+00;Horizontal Mode,Main;SincET
Mode,Real Time;Sampling Period,1.000E-07;Time,22-
Sep-16 10:44:28;
Waveform Data;
#520000.....follows waveform block
data.....
```

Label Commands

:CHANnel<X>:LABel.....	228
:CHANnel<X>:LABel:DISPlay.....	229
:REF<X>:LABel.....	229
:REF<X>:LABel:DISPlay.....	230
:BUS1:LABel.....	231
:BUS1:LABel:DISPlay.....	231
:D<x>:LABel.....	232
:D<x>:LABel:DISPlay.....	233
:DIGital:ANALog:A<x>:LABel.....	233
:DIGital:ANALog:A<x>:LABel:DISPlay.....	234
:SET<X>:LABel.....	235

:CHANnel<X>:LABel

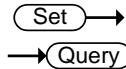

Description	Sets or returns the file label for the selected channel.	
Syntax	:CHANnel<X>:LABel {<string> ?}	
Related commands	:CHANnel<X>:LABel:DISPlay	
Parameter	<X>	Channel 1, 2, 3, 4
	<string>	The string must be no more than 8 characters and only contain alphanumeric characters in addition to period, dash and underscore characters. The string must be enclosed in double quotes, "string".
Return parameter	<string>	Returns the label for the selected channel. No return indicates that there has not been a file label assigned for the selected channel.

Example1 :CHANnel1:LABel "CH1_lab"
Sets the channel 1 label as "CH1_lab".

Example2 :CHANnel1:LABel?
CH1_lab

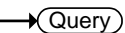
:CHANnel<X>:LABel:DISPlay  

Description Turns the label on/off for the selected channel or returns its status.

Syntax :CHANnel<X>:LABel:DISPlay { OFF | ON | ? }

Related commands :CHANnel<X>:LABel

Parameter	<X>	Channel 1, 2, 3, 4
	OFF	Turns the file label off for the selected channel.
	ON	Turns the file label on for the selected channel.

Return parameter Returns the status of the file label for the selected channel (ON, OFF).

Example :CHANnel1:LABel "CH1"
:CHANnel1:LABel:DISPlay ON
:CHANnel1:LABel:DISPlay?
ON
Sets the channel 1 label to "CH1" and then turns the label display on. The query return shows that the label is on.

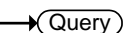
:REF<X>:LABel  

Description Sets or returns the file label for the selected reference waveform.

Syntax :REF<X>:LABel {<string> | ?}

Related commands	:REF<X>:LABel:DISPlay	
Parameter	<X>	REF 1, 2, 3, 4
	<string>	The string must be no more than 8 characters and only contain alphanumeric characters in addition to period, dash and underscore characters. The string must be enclosed in double quotes, "string".
Return parameter	<string>	Returns the label for the selected reference waveform. No return indicates that there has not been a file label assigned for the selected reference waveform.

Example1 :REF1:LABel "REF1_lab"
 Sets the REF1 label as "REF1_lab".

Example2 :REF1:LABel?
 REF1_lab



Description	Turns the label on/off for the selected reference waveform or returns its status.	
Syntax	:REF<X>:LABel:DISPlay { OFF ON ? }	
Related commands	:REF<X>:LABel	
Parameter	<X>	Reference waveform 1, 2, 3, 4
	OFF	Turns the file label off for the selected reference waveform.
	ON	Turns the file label on for the selected reference waveform.
Return parameter	Returns the status of the file label for the selected reference waveform (ON, OFF).	

Example :REF1:LABel "REF1"
 :REF1:LABel:DISPlay ON
 :REF1:LABel:DISPlay?
 ON

Sets the label for reference waveform 1 to "REF1" and then turns the label display on. The query return shows that the label is on.

:BUS1:LABel

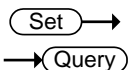

Description	Sets or returns the file label for the bus.	
Syntax	:BUS1:LABel {<string> ?}	
Related commands	:BUS1:LABel:DISPlay	
Parameter	<string>	The string must be no more than 8 characters and only contain alphanumeric characters in addition to period, dash and underscore characters. The string must be enclosed in double quotes, "string".
Return parameter	<string>	Returns the label for the bus. No return indicates that there has not been a file label assigned for bus.

Example1 :BUS1:LABel "Bus"
 Sets the bus label as "Bus".

Example2 :BUS1:LABel?
 Bus

:BUS1:LABel:DISPlay

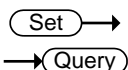

Description	Turns the label on/off for the bus or returns its status.	
Syntax	:BUS1:LABel:DISPlay { OFF ON ? }	

Related commands	:BUS1:LABel	
Parameter	OFF	Turns the file label off for the bus.
	ON	Turns the file label on for the bus.
Return parameter	Returns the status of the file label for the bus (ON, OFF).	
Example	:BUS1:LABel "Bus"	
	:BUS1:LABel:DISPlay ON	
	:BUS1:LABel:DISPlay?	
	ON	
	Sets the label for the bus to "Bus" and then turns the label display on. The query return shows that the label is on.	

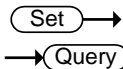

:D<x>:LABel

Description	Sets or returns the waveform label for digital channels.	
Syntax	:D<x>:LABel {<string> ?}	
Related commands	:D<x>:LABel:DISPlay	
Parameter	<x>	Digital channel number D0~D15
	<string>	The string must be no more than 8 characters and only contain alphanumeric characters in addition to period, dash and underscore characters. The string must be enclosed in double quotes, "string".
Return parameter	<string>	Returns the label for the bus. No return indicates that there has not been a file label assigned for bus.
Example	:D1:LABel "D1"	
	Sets the digital channel 1 label as "D1".	

:D<x>:LABel:DISPlay

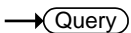

Description	Turns the label on/off for the selected digital channel or returns its status.	
Syntax	:D<x>:LABel:DISPlay { OFF ON ? }	
Related commands	:D<x>:LABel	
Parameter	OFF	Turns the file label off for the selected digital channel.
	ON	Turns the file label on for the selected digital channel.
Return parameter	Returns the status of the file label for the digital channel (ON, OFF).	

Example

```
:D1:LABel "D1"
:D1:LABel?
>D1
:D1:LABel:DISPlay ON
D1:LABel:DISPlay?
ON
```

Sets the label for the D1 channel to "D1" and then turns the label display on. The query return shows that the label is on.

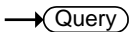
:DIGital:ANALog:A<x>:LABel



Description	Sets or returns the label for analog waveforms.	
Syntax	:DIGital:ANALog:A<x>:LABel {<string> ?}	
Related commands	:DIGital:ANALog:A<x>:LABel:DISPlay	
Parameter	<x>	Analog waveform number (1~2).

	<string>	The string must be no more than 8 characters and only contain alphanumeric characters in addition to period, dash and underscore characters. The string must be enclosed in double quotes, "string".
--	----------	--

Return parameter	<string>	Returns the label for the bus. No return indicates that there has not been a file label assigned for bus.
------------------	----------	---

Example :DIG:ANA:A1:LAB "A1"
 Sets the analog waveform 1 label as "A1".

:DIGital:ANALog:A<x>:LABel:DISPlay  

Description	Turns the label on/off for the analog waveform or returns its status.	
-------------	---	--

Syntax	:DIGital:ANALog:A<x>:LABel:DISPlay { OFF ON ? }	
--------	---	--

Related commands	:DIGital:ANALog:A<x>:LABel	
------------------	----------------------------	--

Parameter	OFF	Turns the file label off for the analog waveform.
	ON	Turns the file label on for the analog waveform.

Return parameter	Returns the status of the file label for the analog waveform (ON, OFF).	
------------------	---	--



Example :DIGital:ANALog:A1:LABel "A1"
 :DIGital:ANALog:A1:LABel:DISPlay ON
 :DIGital:ANALog:A1:LABel:DISPlay?
 ON
 Sets the label for the analog waveform to "A1" and then turns the label display on. The query return shows that the label is on.

:SET<X>:LABel 

Description	Sets or returns the file label for the selected setup.	
Syntax	:SET<X>:LABel {<string> ?}	
Related commands	:SET<X>:LABel:DISPlay	
Parameter	<X>	Setup number 1 to 20
	<string>	The string must be no more than 8 characters and only contain alphanumeric characters in addition to period, dash and underscore characters. The string must be enclosed in double quotes, "string".
Return parameter	<string>	Returns the label for the selected setup. No return indicates that there has not been a file label assigned for the selected setup.
Example1	:SET1:LABel "SET1_lab" Sets the label for setup 1 as "SET1_lab".	
Example2	:SET1:LABel? SET1_lab	

Segment Commands

:SEGMENTS:STATE	236
:SEGMENTS:CURRENT.....	237
:SEGMENTS:TOTALNUM	237
:SEGMENTS:TIME	238
:SEGMENTS:DISPALL	238
:SEGMENTS:MEASURE:MODE	238
:SEGMENTS:MEASURE:PLOT:SOURCE	239
:SEGMENTS:MEASURE:PLOT:DIVIDE.....	239
:SEGMENTS:MEASURE:PLOT:SELECT	240
:SEGMENTS:MEASURE:PLOT:RESULTS	240
:SEGMENTS:MEASURE:TABLE:SOURCE	241
:SEGMENTS:MEASURE:TABLE:SELECT.....	241
:SEGMENTS:MEASURE:TABLE:LIST	242
:SEGMENTS:MEASURE:TABLE:SAVE	242
:SEGMENTS:SAVE	242
:SEGMENTS:SAVE:SOURCE	243
:SEGMENTS:SAVE:SELECT:START	243
:SEGMENTS:SAVE:SELECT:END	244

		
:SEGMENTS:STATE		
Description	Turns the segmented memory function on/off or queries its state.	
Syntax	:SEGMENTS:STATE { OFF ON ? }	
Related commands	:RUN :STOP	
Parameter/ Return parameter	OFF	Turns the segmented memory off.
	ON	Turns the segmented memory on.
Example1	:SEGMENTS:STATE ON Turns segmented memory on.	

Set →
 → Query

:SEGMents:CURRent		
Description	Sets or queries the current segment. The total number of segments depends on the record length.	
Syntax	:SEGMents:CURRent {SETTOMIN SETTOMAX <NR1> ?}	
Related commands	:SEGMents:STATE :SEGMents:TOTAlnum	
Parameter/ Return parameter	SETTOMIN	Current segment = min segment
	SETTOMAX	Current segment = max segment
	<NR1>	1~29000
Example1	:SEGMents:CURRent 10 Sets the current segment to segment number 10.	

Set →
 → Query

:SEGMents:TOTAlnum		
Description	Sets or queries the total number of segments for the segmented memory function. The total number of segments depends on the record length.	
Syntax	:SEGMents:TOTAlnum {SETTOMIN SETTOMAX <NR1> ?}	
Related commands	:SEGMents:STATE :SEGMents:CURRent	
Parameter/ Return parameter	SETTOMIN	Sets to the minimum number
	SETTOMAX	Sets to the maximum number
	<NR1>	1~29000
Example1	:SEGMents:TOTAlnum SETTOMAX Sets the number of segments to max number (29000).	

:SEGMents:TIME → (Query)

Description	Returns the time of the current segment in relation to the first segment.
Syntax	:SEGMents:TIME?
Related commands	:SEGMents:STATE :SEGMents:CURREnt
Return parameter	The segment time as <NR3>.
Example	:SEGMents:TIME? >8.040E-03 Returns the segment time.

:SEGMents:DISPALL (Set) →
→ (Query)

Description	Sets or queries whether all the segments are displayed on the screen.
Syntax	:SEGMents:DISPALL {OFF ON ?}
Related commands	:SEGMents:STATE :SEGMents:CURREnt
Parameter/ Return parameter	OFF Turns the display all function off. ON Turns the display all function on.
Example1	:SEGMents:DISPALL ON Turns the display all function on.

:SEGMents:MEASure:MODE (Set) →
→ (Query)

Description	Sets or queries the measurement mode.
Syntax	:SEGMents:MEASure:MODE {OFF PLOT TABLE ?}
Related commands	:MEASUrement:MEAS<x>

Parameter/ Return parameter	OFF	Disables the automatic measurement function for the segments measurement.
	PLOT	Sets the measurement mode to Statistics.
	TABLE	Sets the measurement mode to a measurement list.

Example :SEGMents:MEASure:MODE?
 >PLOT

 Returns the measurement mode as Statistics.

Set →
 → Query

Description	Sets or queries the statistics source.	
Syntax	:SEGMents:MEASure:PLOT:SOURce {<NR1> ? }	
Related commands	:SEGMents:MEASure:MODE :SEGMents:MEASure:PLOT:DIVide :SEGMents:MEASure:PLOT:SElect :SEGMents:MEASure:PLOT:RESults	

Parameter/ Return parameter	<NR1>	1~8 (Automatic measurement item 1~8)
--------------------------------	-------	--------------------------------------

Example1 :SEGMents:MEASure:PLOT:SOURce 1

 Sets the source as auto measurement item 1.

Set →
 → Query

Description	Sets or queries the number of bins for the statistics function.	
Syntax	:SEGMents:MEASure:PLOT:DIVide {<NR1> ? }	
Related commands	:SEGMents:MEASure:PLOT:SOURce :SEGMents:MEASure:PLOT:SElect	

Parameter/ Return parameter	<NR1>	1~20
--------------------------------	-------	------

Example1 :SEGMents:MEASure:PLOT:DIVide 5
Sets the number of bins to 5 for the statistics function.

:SEGMents:MEASure:PLOT:SElect (Set) →
← (Query)

Description Sets or queries which bin to view the statics of.

Syntax :SEGMents:MEASure:PLOT:SElect {<NR1> | ? }

Related commands :SEGMents:MEASure:PLOT:SOURce
:SEGMents:MEASure:PLOT:DIVide

Parameter	<NR1>	1~20 (cannot exceed the number of bins)
-----------	-------	--

Return parameter Return the bin number as <NR3>.

Example1 :SEGMents:MEASure:PLOT:SElect 5
Set to bin number 5.

:SEGMents:MEASure:PLOT:RESults ← (Query)

Description Returns the results of the currently selected bin for the statistics measurement.

Note At least one automatic measurement must be turned on.

Syntax :SEGMents:MEASure:PLOT:RESults?

Related commands :SEGMents:STATE
:SEGMents:MEASure:MODE PLOT
:SEGMents:MEASure:PLOT:SOURce
:SEGMents:MEASure:PLOT:DIVide
:SEGMents:MEASure:PLOT:SElect

Return parameter Returns the statistics measurements as a string.

Example :SEGMents:STATE ON
 STOP
 :SEGMents:MEASure:MODE PLOT
 :SEGMents:MEASure:PLOT:SOURce 1
 :SEGMents:MEASure:PLOT:DIVide 10
 :SEGMents:MEASure:PLOT:SElect 1
 :SEGMents:MEASure:PLOT:RESults?
 > MAX,1.000kHz;MIN,1.000kHz;MEAN,1.000kHz;
 Bin Statistics,1 of 10;Percent,10.00%;Count,1;
 Measured,10;Unmeasured,0;Bin Range,
 1.000kHz~1.000kHz;
 Plots the results for automatic measurement #1,
 bin 1 of 10.

:SEGMents:MEASure:TABLE:SOURce
 Set →
 Query

Description Sets or queries the source of the measurement list.

Syntax :SEGMents:MEASure:TABLE:SOURce {CH1 | CH2 | CH3| CH4 | ? }

Related commands :SEGMents:MEASure:MODE
 :SEGMents:MEASure:TABLE:SElect
 :SEGMents:MEASure:TABLE:LIST

Parameter/ Return parameter CH1~CH4 Channel 1 to 4

Example1 :SEGMents:MEASure:TABLE:SOURce CH1
 Sets the source to CH1.

:SEGMents:MEASure:TABLE:SElect
 Set →
 Query

Description Sets or queries a segment to view in the measurement table.

Syntax :SEGMents:MEASure:TABLE:SElect {<NR1> | ? }

Related commands	:SEGMents:TOTAlnum
Parameter	<NR1> 1~29000
Return parameter	Returns the number of segments as <NR3>.
Example1	:SEGMents:MEASure:TABLE:SElect 10 Select segment number 10.

:SEGMents:MEASure:TABLE:LIST → Query

Description	Returns the measurement results of each segment in the list.
Syntax	:SEGMents:MEASure:TABLE:LIST?
Return parameter	Returns the measurements results as a string for each segment.
Example	:SEGMents:MEASure:TABLE:LIST? >"GW MSO-2074E, serial number PXXXXXX, version V1.11",Segment Summary : CH1, Seg.,Pk- Pk (V),Pk-Pk (V),1,8.00m,8.00m.....etc

:SEGMents:MEASure:TABLE:SAVE Set →

Description	Saves the list of segment automatic measurement results.
Syntax	:SEGMents:MEASure:TABLE:SAVE

:SEGMents:SAVE Set →

Description	Saves the segments.
Syntax	:SEGMents:SAVE
Related Commands	:SEGMents:SAVE:SOURce :SEGMents:SAVE:SElect:STARt :SEGMents:SAVE:SElect:END

Example :SEGMents:SAVe:SOURce CH1
 :SEGMents:SAVe:SElect:STARt 1
 :SEGMents:SAVe:SElect:END 10
 :SEGMents:SAVe

:SEGMents:SAVe:SOURce

Set →

→ Query

Description Sets or queries the source segment waveform to save.

Syntax :SEGMents:SAVe:SOURce {CH1 | CH2 | CH3 | CH4 | D0 | D1 | D2 | D3 | D4 | D5 | D6 | D7 | D8 | D9 | D10 | D11 | D12 | D13 | D14 | D15 | ? }

Parameter/ Return parameter	CH1~CH4	Channel 1 to 4.
	D0~D15	Digital channels D0~D15

Example :SEGMents:SAVe:SOURce CH1
 >Sets the source to CH1.

Set →

→ Query

:SEGMents:SAVe:SElect:STARt

Description Sets or queries the starting segment to save from. The number of possible segments depends on the record length.

Syntax :SEGMents:SAVe:SElect:STARt {SETTOMIN | SETTOMAX | <NR1> | ? }

Related commands :SEGMents:TOTAlnum

Parameter/ Return parameter	SETTOMIN	Sets the starting segment to min segment.
	SETTOMAX	Sets the starting segment to the max segment.
	<NR1>	Sets the segment to 1~29000

Example :SEGMents:SAVe:SELEct:STARt 2
 Sets the starting segment to segment number 2.

:SEGMents:SAVe:SELEct:END (Set) →
 → (Query)

Description Sets or queries the ending segment to save from. The number of possible segments depends on the record length.

Syntax :SEGMents:SAVe:SELEct:END
 {SETTOMIN | SETTOMAX | <NR1> | ? }

Related commands :SEGMents:TOTalnum

Parameter/ Return parameter	SETTOMIN	Sets the starting segment to min segment.
	SETTOMAX	Sets the starting segment to the max segment.
	<NR1>	Sets the segment to 1~29000.

Return parameter	<NR3>	Returns the ending segment as NR3.
------------------	-------	------------------------------------

Example :SEGMents:SAVe:SELEct:END 10
 Sets the ending segment to segment number 10.

DVM Commands

The DVM commands are only available when the optional DVM software is installed.

:DVM:STATE	245
:DVM:SOURce	245
:DVM:MODE.....	246
:DVM:VALue	246

:DVM:STATE

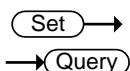

Description	Sets or queries the DVM state to on or off.	
Syntax	:DVM:STATE {OFF ON ? }	
Related commands	:DVM:SOURce :DVM:MODE	
Parameter/ Return parameter	OFF	Turns the DVM off.
	ON	Turns the DVM on.
Example	:DVM:STATE ON Turns the DVM state on.	

:DVM:SOURce

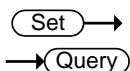

Description	Sets or queries the source of the DVM.	
Syntax	:DVM:SOURce {CH1 CH2 CH3 CH4 ?}	
Related commands	:DVM:STATE :DVM:MODE	
Parameter/ Return parameter	CH1~CH4	Channel 1 to 4.
Example	:DVM:SOURce CH1 Sets the DVM source to channel 1.	

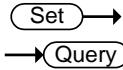

:DVM:MODE

Description	Sets or queries the DVM mode.	
Syntax	:DVM:MODE {ACRMS DC DCRMS DUTY FREQUENCY ?}	
Related commands	:DVM:SOURce :DVM:STATE	
Parameter/ Return parameter	ACRMS	Sets the mode to AC RMS
	DC	Sets the mode to DC
	DCRMS	Sets the mode to DC RMS
	DUTY	Sets the mode to AC Duty
	FREQUENCY	Sets the mode to AC frequency
Example	:DVM:MODE DUTY Sets the DVM mode to DUTY.	

:DVM:VALue



Description	Returns the measurement value of the selected mode.	
Syntax	:DVM:VALue?	
Related commands	:DVM:SOURce :DVM:STATE :DVM:MODE	
Return parameter	Returns the measurement value as <NR3>.	
Example	:DVM:VALue? >8.410E-04 Returns the measurement.	

Go_NoGo Commands

The GoNoGo APP must first be launched (or use the command, “:GONogo:SCRipt”) before any of the Go_NoGo or Template commands can be used.

:GONogo:CLEar.....	247
:GONogo:EXECute	247
:GONogo:FUNcTion.....	248
:GONogo:NGCounT.....	248
:GONogo:NGDefine.....	248
:GONogo:SOURce.....	249
:GONogo:VIOLation.....	249
:GONogo:SCRipt	249
:TEMPlate:MODe	250
:TEMPlate:MAXimum.....	250
:TEMPlate:MINimum	250
:TEMPlate:POSition:MAXimum.....	251
:TEMPlate:POSition:MINimum	251
:TEMPlate:SAVe:MAXimum	251
:TEMPlate:SAVe:MINimum	252
:TEMPlate:TOLerance.....	252
:TEMPlate:SAVe:AUTO.....	252

:GONogo:CLEar

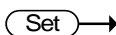

Description Clears the Go/NoGo counter.

Syntax :GONogo:CLEar

:GONogo:EXECute

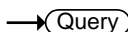
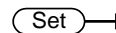

Description Enables or disables the Go/NoGo function or queries its state.

Syntax :GONogo:EXECute {OFF|ON|?}

Parameter/	OFF	Disabled
Return Parameter	ON	Enabled
Example	:GONogo:EXECute OFF Turns Go/NoGo off.	

:GONogo:FUNCTION (Set) →

Description Initializes the Go/NoGo APP. This must be run after the Go/NoGo APP has been started.

Syntax :GONogo:FUNCTION

:GONogo:NGCount → (Query)

Description Returns the Go/NoGo counter.

Syntax :GONogo:NGCount{?}

Return parameter Returns a string in the following format “number of violations,total tests”

Example :GONogo:NGCount?
> 3,25
Indicates that 3 violations occurred over 25 tests.

:GONogo:NGDefine (Set) →
→ (Query)

Description Sets the Go/NoGo “When” conditions.

Syntax :GONogo:NGDefine {EXITs|ENTers|?}

Parameter/ Return Parameter	EXITs	Sets the NoGo condition to when the input signal exceeds the limit boundary.
	ENTers	Sets the NoGo condition to when the input signal stays within the limit boundary.

Example :GONogo:NGDefine EXITs
Sets the Go/NoGo condition to EXITs.



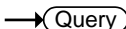

:GONogo:SOURce

Description	Sets the source for the Go/NoGo signal.	
Syntax	:GONogo:SOURce {CH1 CH2 CH3 CH4 ?}	
Parameter/ Return Parameter	CH1~CH4	
Example	:GONogo:SOURce CH1 Sets the source to CH1.	



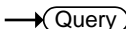

:GONogo:VIOLation

Description	Sets or returns actions for the Go/NoGo violations.	
Syntax	:GONogo:VIOLation {STOP CONTInue ?}	
Parameter/ Return Parameter	STOP	The waveform will be frozen.
	CONTInue	Ignore the violation.
Example	:GONogo:VIOLation STOP Sets violation action to STOP.	



:GONogo:SCRipt

Description	Activates/Deactivates the Go/NoGo APP or queries its state.	
Syntax	:GONogo:SCRipt {OFF ON ?}	
Parameter/ Return Parameter	ON	Turns Go/NoGo APP on.
	OFF	Turns the Go/NoGo APP off.
Example	:GONogo:SCRipt? >ON The Go/NoGo script is on.	

Set →
← Query

:TEMPlate:MODE

Description	Sets or returns the Go/NoGo template mode.	
Syntax	:TEMPlate:MODE {MAXimum MINimum AUTO ?}	
Parameter/ Return Parameter	MAXimum	Maximum template
	MINimum	Minimum template
	AUTO	Auto template
Example	:TEMPlate:MODE AUTO Sets the template mode to AUTO.	

Set →
← Query

:TEMPlate:MAXimum

Description	Defines or queries which waveform memory (REF1 or W1~W20) is set to the maximum template.	
Syntax	:TEMPlate:MAXimum {REF1 W1~W20 ?}	
Parameter/ Return Parameter	REF1	Reference one
	W1~W20	Waveform memory 1 to 20
Example	:TEMPlate:MAXimum REF1 Saves the maximum template to REF1.	

Set →
← Query

:TEMPlate:MINimum

Description	Defines or queries which waveform memory (REF1 or W1~W20) is set to the minimum template.	
Syntax	:TEMPlate:MINimum {REF2 W1~W20 ?}	
Parameter/ Return Parameter	REF2	Reference one
	W1~W20	Waveform memory 1 to 20
Example	:TEMPlate:MINimum REF2 Saves the minimum template to REF2.	

:TEMPlate:POSition:MAXimum



Description	Sets or queries the position of the maximum template.	
Syntax	:TEMPlate:POSition:MAXimum {<NR2> ?}	
Parameter	<NR2>	Desired template position (-12.0 ~ +12.0 divisions)
Return parameter	Returns the position in the following format: “<NR2>Div”	
Example	:TEMPlate:POSition:MAXimum 3.00 Sets the maximum template position to 3.00 divisions.	

:TEMPlate:POSition:MINimum



Description	Sets or queries the position of the minimum template.	
Syntax	:TEMPlate:POSition:MINimum {<NR2> ?}	
Parameter	<NR2>	Desired template position (-12.0 ~ +12.0 divisions)
Return parameter	Returns the position in the following format: “<NR2>Div”	
Example	:TEMPlate:POSition:MINimum 3.00 Sets the minimum template position to 3.00 divisions.	

:TEMPlate:SAVe:MAXimum 

Description	Saves the maximum template.	
Syntax	:TEMPlate:SAVe:MAXimum	

:TEMPlate:SAVe:MINimum

Set →

Description Saves the maximum template.

Syntax :TEMPlate:SAVe:MINimum

Set →

:TEMPlate:TOLerance

→ Query

Description Sets or queries the tolerance as a percentage.

Syntax :TEMPlate:TOLerance {<NR2>{?}}

Parameter/ Return Parameter	<NR2>	The auto tolerance range (0.4% ~ 40%)
--------------------------------	-------	---------------------------------------

Example :TEMPlate:TOLerance 10
 Sets the tolerance to 10%.

:TEMPlate:SAVe:AUTo

Set →

Description Saves the AUTO template (maximum and minimum templates).

Syntax :TEMPlate:SAVe:AUTo

AWG Commands

The Arbitrary Wave Generator is available on the MSO-2000EA only.

:AWG<x>:AMPlitude.....	254
:AWG<x>:FREQuency.....	254
:AWG<x>:FUNCtion.....	255
:AWG<x>:OFFSet.....	256
:AWG<x>:OUTPut:LOAD:IMPEDance.....	256
:AWG<x>:OUTPut:STATE.....	256
:AWG<x>:PHAsE.....	257
:AWG<x>:PULSe:DUTYcycle.....	257
:AWG<x>:RAMP:SYMmetry.....	257
:AWG<x>:MODulation:STATE.....	258
:AWG<x>:MODulation:TYPe.....	258
:AWG<x>:MODulation:AM:DEPth.....	258
:AWG<x>:MODulation:AM:FREQ.....	259
:AWG<x>:MODulation:AM:SHApe.....	259
:AWG<x>:MODulation:AM:PHAsE.....	259
:AWG<x>:MODulation:AM:DUTYcycle.....	260
:AWG<x>:MODulation:AM:SYMmetry.....	260
:AWG<x>:MODulation:AM:RATE.....	260
:AWG<x>:MODulation:FM:DEV.....	261
:AWG<x>:MODulation:FM:FREQ.....	261
:AWG<x>:MODulation:FM:SHApe.....	262
:AWG<x>:MODulation:FM:PHAsE.....	262
:AWG<x>:MODulation:FM:DUTYcycle.....	263
:AWG<x>:MODulation:FM:SYMmetry.....	263
:AWG<x>:MODulation:FM:RATE.....	263
:AWG<x>:MODulation:FSK:FREQ.....	264
:AWG<x>:MODulation:FSK:RATE.....	264
:AWG<x>:SWEep:STATE.....	265
:AWG<x>:SWEep:TYPe.....	265
:AWG<x>:SWEep:START.....	265
:AWG<x>:SWEep:STOP.....	266

:AWG<x>:SWEep:TIME..... 266
 :AWG<x>:SWEep:SPAN 266
 :AWG<x>:SWEep:CENTEr 267
 :AWG<x>:ARBItrary:EDIT:NUMPOINt 267
 :AWG<x>:ARBItrary:EDIT:FUNCTion 267
 :AWG<x>:ARBItrary:SAVe:WAVEform 268
 :AWG<x>:ARBItrary:LOAD:WAVEform 268
 :AWG<x>:ARBItrary:EDIT:COPI 269
 :AWG<x>:ARBItrary:EDIT:CLEAr 269
 :AWG<x>:ARBItrary:EDIT:LINE 270
 :AWG<x>:ARBItrary:EDIT:SCALE 270
 :AWG<x>:ARBItrary:EDIT:POINt..... 270
 :AWG<x>:ARBItrary:EDIT:POINt:ADD..... 271
 :AWG<x>:ARBItrary:EDIT:POINt:DELEte 271

:AWG<x>:AMPlitude (Set) →
→ (Query)

Description	Sets or returns the waveform amplitude.	
Syntax	:AWG<x>:AMPlitude {<NRf> ?}	
Related command	:AWG<x>:OUTPut:LOAD:IMPEDance	
Parameter/ Return parameter	<x> <NRf>	Channel number 1~2. Amplitude in Volts. (50Ω impedance 0.1~2.5V) (High Z impedance 0.2~5V)
Example	:AWG1:AMP 1	

:AWG<x>:FREQuency (Set) →
→ (Query)

Description	Sets or returns the waveform frequency.	
Syntax	:AWG<x>:FREQuency {<NRf> ?}	
Parameter/	<x>	Channel number 1~2.

Return parameter <NRF> Frequency in Hertz.

Example :AWG1:FREQ 2000

Set →

:AWG<x>:FUNction

→ Query

Description Sets or returns the type of waveform.

Syntax :AWG<x>:FUNction {ARBitrary | SINE | SQUAre | PULSe | RAMP | DC | NOISe | SINC | GAUSSian | LORENTz | EXPRise | EXPFall | HAVERSINe | CARDIac | ?}

Parameter/ Return parameter	<x>	Channel number 1~2.
	ARBitrary	Arbitrary waveform
	SINE	Sine waveform
	SQUAre	Square waveform
	PULSe	Pulse waveform
	RAMP	Ramp waveform
	DC	DC waveform
	NOISe	Noise waveform
	SINC	Sinc waveform
	GAUSSian	Gaussian waveform
	LORENTz	Lorentz waveform
	EXPRise	Exponential rise waveform
	EXPFall	Exponential fall waveform
	HAVERSINe	Haversine waveform
	CARDIac	Cardiac waveform

Example :AWG1:FUNc?>SINE

Set →
 → Query

:AWG<x>:OFFSet

Description	Sets or returns the waveform offset.	
Syntax	:AWG<x>:OFFSet {<Nrf> ?}	
Parameter/ Return parameter	<x>	Channel number 1~2.
	<Nrf>	Offset in Volts.
Example	:AWG1:OFFS	

Set →
 → Query

:AWG<x>:OUTPut:LOAd:IMPEDance

Description	Sets or returns the output termination	
Syntax	:AWG<x>:OUTPut:LOAd:IMPEDance {FIFTy HIGHZ ?}	
Parameter/ Return parameter	<x>	Channel number 1~2
	FIFTy	50 Ohm output termination
	HIGHZ	High Z output termination
Example	:AWG1:OUTP:LOA:IMPED HIGHZ Sets the output termination of channel 1 to high impedance.	

Set →
 → Query

:AWG<x>:OUTPut:STATE

Description	Sets or returns the channel output state.	
Syntax	:AWG<x>:OUTPut:STATE {OFF ON ?}	
Parameter/ Return parameter	<x>	Channel number 1~2
	OFF	Turns the channel output off
	ON	Turns the channel output on
Example	:AWG1:OUTP:STATE OFF Turns the channel 1 output off.	



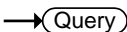

:AWG<x>:PHASe

Description	Sets or returns the channel phase.	
Syntax	:AWG<x>:PHASe {<NRf> ?}	
Parameter/ Return parameter	<x>	Channel number 1~2.
	<NRf>	Phase in degree -180~180°
Example	:AWG1:PHA 45 Sets the channel 1 phase to 45°.	





:AWG<x>:PULSe:DUTYcycle

Description	Sets or returns the pulse duty cycle.	
Syntax	:AWG<x>:PULSe:DUTYcycle {<NRf> ?}	
Parameter/ Return parameter	<x>	Channel number 1~2.
	<NRf>	Duty cycle in percentage 0.2~99.8%
Example	:AWG1:PULS:DUTY 50 Sets the channel 1 pulse duty cycle to 50%.	





:AWG<x>:RAMP:SYMmetry

Description	Sets or returns the ramp symmetry.	
Syntax	:AWG<x>:RAMP:SYMmetry {<NRf> ?}	
Parameter/ Return parameter	<x>	Channel number 1~2.
	<NRf>	Symmetry of the ramp waveform 0~100%
Example	:AWG1:RAMP:SYM 15 Sets the channel 1 ramp symmetry to 15%.	

:AWG<x>:MODulation:STATE (Set) →
→ (Query)

Description	Sets or returns the modulation state.	
Syntax	:AWG<x>:MODulation:STATE {OFF ON ?}	
Parameter/ Return parameter	<x>	Channel number 1~2.
	OFF	Sets the modulation to off.
	ON	Sets the modulation to on.
Example	:AWG1:MOD:STATE ON Turns the modulation on for channel 1.	

:AWG<x>:MODulation:TYPE (Set) →
→ (Query)

Description	Sets or returns the type of modulation.	
Syntax	:AWG<x>:MODulation:TYPE {AM FM FSK ?}	
Parameter/ Return parameter	<x>	Channel number 1~2.
	AM	Sets a AM modulation.
	FM	Sets a FM modulation.
	FSK	Sets a FSK modulation.
Example	:AWG1:MOD:TYPE AM Sets a AM modulation for channel 1.	

:AWG<x>:MODulation:AM:DEPth (Set) →
→ (Query)

Description	Sets or returns the AM modulation depth.	
Syntax	:AWG<x>:MODulation:AM:DEPth {<NRf> ?}	
Parameter/ Return parameter	<x>	Channel number 1~2.
	<NRf>	AM depth in percentage 0~120%.
Example	:AWG1:MOD:AM:DEP? >1.20000e+02	

Set →
 → Query

:AWG<x>:MODulation:AM:FREQ

Description Sets or returns the AM modulation frequency.

Syntax :AWG<x>:MODulation:AM:FREQ {<NRf> | ?}

Parameter/ Return parameter	<x>	Channel number 1~2.
	<NRf>	AM frequency in Hertz.

Example :AWG1:MOD:AM:FREQ 1000
Sets the AM frequency to 1kHz.

Set →
 → Query

:AWG<x>:MODulation:AM:SHApe

Description Sets or returns the shape of the AM modulation.

Syntax :AWG<x>:MODulation:AM:SHApe {SINE | SQUare | PULSe | RAMP | NOISe | ?}

Parameter/ Return parameter	<x>	Channel number 1~2.
	SINE	Sine wave shape.
	SQUare	Square wave shape.
	PULSe	Pulse wave shape.
	RAMP	Ramp wave shape.
	NOISe	Noise wave shape.

Example :AWG1:MOD:AM:SHA RAMP
Sets a ramp shape to the AM modulating waveform.

Set →
 → Query

:AWG<x>:MODulation:AM:PHAsE

Description Sets or returns the phase of the AM modulation (sine wave shape only).

Syntax :AWG<x>:MODulation:AM:PHAsE {<NRf> | ?}

Parameter/	<x>	Channel number 1~2.
-------------------	------------------	---------------------

Return parameter <NRf> Phase in degree -180~180°.

Example :AWG1:MOD:AM:PHA?
>-1.80000e+02

Set →

→ Query

:AWG<x>:MODulation:AM:DUTYcycle

Description Sets or returns the duty cycle of the AM modulation (pulse wave shape only).

Syntax :AWG<x>:MODulation:AM:DUTYcycle {<NRf> | ?}

Parameter/ Return parameter <x> Channel number 1~2.
<NRf> Duty cycle in percentage 2~98%.

Example :AWG1:MOD:AM:DUTY 50
Sets the duty cycle of the AM modulating waveform to 50%.

Set →

→ Query

:AWG<x>:MODulation:AM:SYMmetry

Description Sets or returns the symmetry of the AM modulation (ramp wave shape only).

Syntax :AWG<x>:MODulation:AM:SYMmetry {<NRf> | ?}

Parameter/ Return parameter <x> Channel number 1~2.
<NRf> Symmetry in percentage 0~100%.

Example :AWG1:MOD:AM:SYM 50
Sets the symmetry of the AM modulating waveform to 50%.

Set →

→ Query

:AWG<x>:MODulation:AM:RATE

Description Sets or returns the rate of the AM modulation (noise wave shape only).

Syntax :AWG<x>:MODulation:AM:RATE {RATE10M | RATE5M | RATE1M | RATE500K | RATE100K | RATE50K | RATE10K | RATE5K | RATE1K | ?}

Parameter/ Return parameter	<x>	Channel number 1~2.
	RATE10M	10MHz noise rate.
	RATE5M	5MHz noise rate.
	RATE1M	1MHz noise rate.
	RATE500K	500kHz noise rate.
	RATE100K	100kHz noise rate.
	RATE50K	50kHz noise rate.
	RATE10K	10kHz noise rate.
	RATE5K	5kHz noise rate.
	RATE1K	1kHz noise rate.

Example :AWG1:MOD:AM:RATE RATE5K
Sets the noise rate of the AM modulating waveform to 5kHz.

:AWG<x>:MODulation:FM:DEV Set →
→ Query

Description Sets or returns the deviation of the FM modulation.

Syntax :AWG<x>:MODulation:FM:DEV {<NRf> | ?}

Parameter/ Return parameter	<x>	Channel number 1~2.
	<NRf>	Frequency deviation in Hertz.

Example :AWG1:MOD:FM:DEV?
>2.000000000e+02

:AWG<x>:MODulation:FM:FREQ Set →
→ Query

Description Sets or returns the frequency of the FM modulation.

Syntax :AWG<x>:MODulation:FM:FREQ {<NRf> | ?}

Parameter/ Return parameter	<x>	Channel number 1~2.
	<NRf>	Frequency in Hertz.

Example :AWG1:MOD:FM:FREQ 1000
 Sets the frequency of the FM modulating waveform to 1kHz.

:AWG<x>:MODulation:FM:SHApe Set →
→ Query

Description	Sets or returns the shape of the FM modulation.	
Syntax	:AWG<x>:MODulation:FM:SHApe {SINE SQUare PULSe RAMP NOISe ?}	
Parameter/ Return parameter	<x>	Channel number 1~2.
	SINE	Sine wave shape.
	SQUare	Square wave shape.
	PULSe	Pulse wave shape.
	RAMP	Ramp wave shape.
	NOISe	Noise wave shape.

Example :AWG1:MOD:FM:SHA SINE
 Sets a sine shape to the FM modulation.

:AWG<x>:MODulation:FM:PHAsE Set →
→ Query

Description	Sets or returns the phase of the FM modulation (sine wave shape only).	
Syntax	:AWG<x>:MODulation:FM:PHAsE {<NRF> ?}	
Parameter/ Return parameter	<x>	Channel number 1~2.
	<NRF>	Phase in degree -180~180°.

Example :AWG1:MOD:FM:PHA 90
 Sets a 90° phase to the FM modulating waveform.

:AWG<x>:MODulation:FM:DUTYcycle
 →
 →

Description	Sets or returns the duty cycle of the FM modulation (pulse shape wave only).	
Syntax	:AWG<x>:MODulation:FM:DUTYcycle {<NRF> ?}	
Parameter/ Return parameter	<x>	Channel number 1~2.
	<NRF>	Duty cycle in percentage 1~99%.
Example	:AWG1:MOD:FM:DUTY 50 Sets the duty cycle of the FM modulating waveform to 50%.	

:AWG<x>:MODulation:FM:SYMmetry
 →
 →

Description	Sets or returns the symmetry of the FM modulation (ramp shape wave only).	
Syntax	:AWG<x>:MODulation:FM:SYMmetry {<NRF> ?}	
Parameter/ Return parameter	<x>	Channel number 1~2.
	<NRF>	Symmetry in percentage 0~100%.
Example	:AWG1:MOD:FM:SYM 50 Sets the symmetry of the FM modulating waveform to 50%.	

:AWG<x>:MODulation:FM:RATE
 →
 →

Description	Sets or returns the noise rate of the FM modulation (noise shape wave only).	
Syntax	:AWG<x>:MODulation:FM:RATE {RATE10M RATE5M RATE1M RATE500K RATE100K RATE50K RATE10K RATE5K RATE1K ?}	
Parameter/ Return parameter	<x>	Channel number 1~2.
	RATE10M	10MHz noise rate.

RATE5M	5MHz noise rate.
RATE1M	1MHz noise rate.
RATE500K	500kHz noise rate.
RATE100K	100kHz noise rate.
RATE50K	50kHz noise rate.
RATE10K	10kHz noise rate.
RATE5K	5kHz noise rate.
RATE1K	1kHz noise rate.

Example :AWG1:MOD:FM:RATE RATE5K
 Sets the noise rate of the FM modulating waveform to 5kHz.

:AWG<x>:MODulation:FSK:FREQ Set →
→ Query

Description Sets or returns the hop frequency of the FSK modulation.

Syntax :AWG<x>:MODulation:FSK:FREQ {<NRf> | ?}

Parameter/ Return parameter	<x>	Channel number 1~2.
	<NRf>	Frequency in Hertz.

Example :AWG1:MOD:FSK:FREQ 2000000
 Sets the FSK hop frequency to 2MHz.

:AWG<x>:MODulation:FSK:RATE Set →
→ Query

Description Sets or returns the FSK modulation rate.

Syntax :AWG<x>:MODulation:FSK:RATE {<NRf> | ?}

Parameter/ Return parameter	<x>	Channel number 1~2.
	<NRf>	Frequency in Hertz.

Example :AWG1:MOD:FSK:RATE 100000
 Sets the FSK rate to 100kHz.

Set →
 → Query

:AWG<x>:SWEep:STATE

Description	Sets or returns the Sweep mode state.	
Syntax	:AWG<x>:SWEep:STATE {OFF ON ?}	
Parameter/ Return parameter	<x>	Channel number 1~2.
	OFF	Sets the sweep mode to off.
	ON	Sets the sweep mode to on.
Example	:AWG1:SWE:STATE ON Turns the sweep mode to on for channel 1.	

Set →
 → Query

:AWG<x>:SWEep:TYPe

Description	Sets or returns the sweep mode type.	
Syntax	:AWG<x>:SWEep:TYPe {LINEAR LOG ?}	
Parameter/ Return parameter	<x>	Channel number 1~2.
	LINEAR	Sets the sweep mode to linear.
	LOG	Sets the sweep mode to logarithmic.
Example	:AWG1:SWE:TYP LIN Sets the sweep mode to linear for channel 1.	

Set →
 → Query

:AWG<x>:SWEep:START

Description	Sets or returns the start frequency of the sweep mode.	
Syntax	:AWG<x>:SWEep:START {<NRf> ?}	
Parameter/ Return parameter	<x>	Channel number 1~2.
	<NRf>	Start frequency in Hertz.
Example	:AWG1:SWE:START 1000 Sets the sweep mode start frequency to 1kHz.	

:AWG<x>:SWEep:STOP (Set) →
→ (Query)

Description	Sets or returns the stop frequency of the sweep mode.	
Syntax	:AWG<x>:SWEep:STOP {<NRF> ?}	
Parameter/ Return parameter	<x>	Channel number 1~2.
	<NRF>	Stop frequency in Hertz.
Example	:AWG1:SWE:STOP 500000 Sets the sweep mode stop frequency to 500kHz.	

:AWG<x>:SWEep:TIME (Set) →
→ (Query)

Description	Sets or returns the sweep time.	
Syntax	:AWG<x>:SWEep:TIME {<NRF> ?}	
Parameter/ Return parameter	<x>	Channel number 1~2.
	<NRF>	Sweep time in seconds.
Example	:AWG1:SWE:TIM 6.500e-01 Sets the sweep time to 650ms.	

:AWG<x>:SWEep:SPAN (Set) →
→ (Query)

Description	Alternatively to setting the start and stop frequencies, the span and center frequency can be set.	
Syntax	:AWG<x>:SWEep:SPAN {<NRF> ?}	
Parameter/ Return parameter	<x>	Channel number 1~2.
	<NRF>	Span of the sweep in Hertz.
Example	:AWG1:SWE:SPAN 1100 Sets the span of the sweep to 1.1kHz.	

:AWG<x>:SWEep:CENTer (Set) →
→ (Query)

Description	Alternatively to setting the start and stop frequencies, the span and center frequency can be set.	
Syntax	:AWG<x>:SWEep:CENTer {<NRf> ?}	
Parameter/ Return parameter	<x>	Channel number 1~2.
	<NRf>	Center frequency of the sweep in Hertz.
Example	:AWG1:SWE:CENT 550 Sets the center frequency of the sweep to 550Hz.	

:AWG<x>:ARBITrary:EDIT:NUMPOINT (Set) →
→ (Query)

Description	Sets or returns the number of points of an arbitrary waveform.	
Syntax	:AWG<x>:ARBITrary:EDIT:NUMPOINT {<NR1> ?}	
Parameter/ Return parameter	<x>	Channel number 1~2.
	<NR1>	Number of points
Example	:AWG1:ARB:EDIT:NUMPOIN 1500 Sets 1500 points for the arbitrary waveform.	

:AWG<x>:ARBITrary:EDIT:FUNCTion (Set) →

Description	Sets the inbuilt waveform of the arbitrary waveform.	
Syntax	:AWG<x>:ARBITrary:EDIT:FUNCTion { SINE SQUare PULSe RAMP NOISe}	
Parameter	<x>	Channel number 1~2.
	SINE	Sine wave shape.
	SQUare	Square wave shape.
	PULSe	Pulse wave shape.

RAMP	Ramp wave shape.
NOISe	Noise wave shape.

Example :AWG1:ARB:EDIT:FUNCT RAMP
Sets a ramp shape to the arbitrary waveform.

:AWG<x>:ARBitrary:SAVe:WAVEform Set →

Description	Saves an arbitrary waveform.	
Syntax	:AWG<x>:ARBitrary:SAVe:WAVEform {ARB1 ARB2 ARB3 ARB4 <file path>}	
Parameter	<x>	Channel number 1~2.
	ARB1~4	Saves the arbitrary waveform to one of the internal memory slots.
	<file path>	Saves the arbitrary waveform to disk or USB to the specified file path. Exemple: "Disk:/xxx.UAW" "USB:/xxx.UAW"

Example :AWG1:ARB:SAVE:WAVE ARB2
Saves the arbitrary waveform to ARB2.

:AWG<x>:ARBitrary:LOAd:WAVEform Set →

Description	Loads an arbitrary waveform.	
Syntax	:AWG<x>:ARBitrary:LOAd:WAVEform { ARB1 ARB2 ARB3 ARB4 <file path>}	
Parameter	<x>	Channel number 1~2.
	ARB1~4	Loads the arbitrary waveform from one of the internal memory slots.
	<file path>	Loads the arbitrary waveform from disk or USB at the specified file path. Exemple: "Disk:/xxx.UAW" "USB:/xxx.UAW"

Example :AWG1:ARB:LOA:WAVE ARB2
Loads the arbitrary waveform from ARB2.

:AWG<x>:ARBitrary:EDIT:COpy 

Description Copies a segment of an arbitrary waveform to a specific point.

Syntax :AWG<x>:ARBitrary:EDIT:COpy {<START> , <LENGth> , <PASTe>}

Parameter	<x>	Channel number 1~2.
	<START>	NR1, point at which the segment to copy starts.
	<LENGth>	NR1, length of the segment to copy.
	<PASTe>	NR1, point at which the segment is to be copied.

Example :AWG1:ARB:EDIT:COpy 5,100,106
Copies a segment of 100 points starting from point 5 of an arbitrary waveform and paste it to point 106 of this arbitrary waveform.

:AWG<x>:ARBitrary:EDIT:CLEar 

Description Deletes a segment of an arbitrary waveform

Syntax :AWG<x>:ARBitrary:EDIT:CLEar { ALL | <START> , <LENGth>}

Parameter	<x>	Channel number 1~2.
	ALL	Deletes the entire arbitrary waveform.
	<START>	NR1, point at which the segment to delete starts.
	<LENGth>	NR1, length of the segment to delete.

Example :AWG1:ARB:EDIT:CLE ALL

:AWG<x>:ARbitrary:EDIT:LINE (Set) →

Description	Creates a line on an arbitrary waveform.	
Syntax	:AWG<x>:ARbitrary:EDIT:LINE {<address1> , <data1> , address2> , <data2>}	
Parameter	<x>	Channel number 1~2.
	<address1>	NR1, the point at which the line starts.
	<data1>	NRf, the value at the starting point.
	<address2>	NR1, the point at which the line ends.
	<data2>	NRf, the value at the ending point.

Example :AWG1:ARB:EDIT:LIN 40,0.05,100,0.1
 Creates a line between point 40 at value 0.05 and point 100 at value 0.01.

:AWG<x>:ARbitrary:EDIT:SCALE (Set) →

Description	Sets the vertical scale of the arbitrary waveform.	
Syntax	:AWG<x>:ARbitrary:EDIT:SCALE {<NRf>}	
Parameter	<x>	Channel number 1~2.
	<NRf>	Scale 0.1~ 10

Example :AWG1:ARB:EDIT:SCAL 5.5

:AWG<x>:ARbitrary:EDIT:POINT (Set) →

Description	Edits a single point on an arbitrary waveform.	
Syntax	:AWG<x>:ARbitrary:EDIT:POINT {<address1> , <data1>}	
Parameter	<x>	Channel number 1~2.
	<address1>	NR1, the point to be edited.
	<data1>	NRf, the value of that point.

Example :AWG1:ARB:EDIT:POIN 20,0.2

:AWG<x>:ARBitrary:EDIT:POINt:ADD 

Description Adds the edited point to the arbitrary waveform.

Syntax :AWG<x>:ARBitrary:EDIT:POINt:ADD {<NR1>}

Parameter	<x>	Channel number 1~2.
	<NR1>	The point to be added.

Example :AWG1:ARB:EDIT:POIN:ADD 20

:AWG<x>:ARBitrary:EDIT:POINt:DELEte 

Description Adds the edited point to the arbitrary waveform.

Syntax :AWG<x>:ARBitrary:EDIT:POINt:DELEte {<NR1>}

Parameter	<x>	Channel number 1~2.
	<NR1>	The point to be deleted.

Example :AWG1:ARB:EDIT:POIN:DELE 20

Data Logging Commands

:DATALOG:STATE	272
:DATALOG:SOURce	272
:DATALOG:SAVe	273
:DATALOG:INTerval.....	273
:DATALOG:DURation.....	274

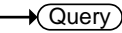
:DATALOG:STATE		 
Description	Sets or queries the state of the data logging app.	
Syntax	:DATALOG:STATE {OFF ON ?}	
Related commands	:DATALOG:SOURce :DATALOG:SAVe :DATALOG:INTerval :DATALOG:DURation	
Parameter/Return parameter	OFF	Turns the data logging off.
	ON	Turns the data logging on.
Example	:DATALOG:STATE ON Turns the data logging app on.	

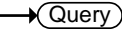
:DATALOG:SOURce		 
Description	Sets or queries the data logging source channel.	
Syntax	:DATALOG:SOURce { CH1~CH4 D0~D15 all ? }	
Related commands	:DATALOG:STATE :DATALOG:SAVe :DATALOG:INTerval :DATALOG:DURation	
Parameter/Return	CH1 ~CH4	Channel 1, 2, 3 or 4

parameter	D0~D15	Digital channels D0~D15
	all	All displayed channels.

Example :DATALOG:SOURce CH1
Sets the source to CH1.

:DATALOG:SAVe (Set) →
→ (Query)

Description Sets or queries the save format as image or waveform.

Syntax :DATALOG:SAVe {IMAGe|WAVEform|?}

Related commands :DATALOG:STATE
:DATALOG:SOURce
:DATALOG:INTerval
:DATALOG:DURation

Parameter/Return parameter	IMAGe	Save as images.
	WAVEform	Save as waveforms.

Example :DATALOG:SAVe WAVEform
Sets the save format to waveform.

:DATALOG:INTerval (Set) →
→ (Query)

Description Sets or queries the recording interval time in seconds. The interval times that can be set are dependent on the settings of the DATALOG:SOURCE and DATALOG:SAVE commands.

Syntax :DATALOG:INTerval {<NR1>|?}

Related commands :DATALOG:STATE
:DATALOG:SOURce
:DATALOG:SAVe
:DATALOG:DURation

Parameter/Return parameter	<NR1>	<p>Sets returns the interval time in discrete seconds:</p> <p>Interval time for DATALOG:SOURCE = All or DATALOG:SAVE=IMAGE: 5, 10, 15, 20, 25, 30, 35, 60, 120</p> <p>Interval time for DATALOG:SOURCE = CH1~CH4: 2, 3, 4, 5, 10, 20, 30, 60, 120</p>
----------------------------	-------	---

Example : DATALOG:INTerval 5
 Sets the recording interval to 5 seconds.

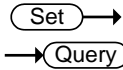

:DATALOG:DURation

Description	Sets or queries the recording duration time in minutes.
Syntax	:DATALOG:DURation {<NR1> ?}
Related commands	:DATALOG:STATE :DATALOG:SOURce :DATALOG:SAVe :DATALOG:INTerval

Parameter/Return parameter	<NR1>	<p>Sets returns the duration time in discrete minutes:</p> <p>5, 10, 15, 20, 25, 30, 60, 90, 120, 150, 180, 210, 240, 270, 300, 330, 360, 390, 420, 450, 480, 510, 540, 570, 600, 1200, 1800, 2400, 3000, 3600, 4200, 4800, 5400, 6000</p>
----------------------------	-------	--

Example : DATALOG:DURation 10
 Sets the recording duration to 10 minutes.

Remote Disk Commands

:REMOTEDisk:IPADdress	275
:REMOTEDisk:PATHName	275
:REMOTEDisk:USERName	275
:REMOTEDisk:PASSWord	276
:REMOTEDisk:MOUNT.....	276
:REMOTEDisk:AUTOMount.....	277

:REMOTEDisk:IPADdress
 Set →
 Query

Description	Sets or returns the IP address of remote disk.
Syntax	:REMOTEDisk:IPADdress {<string> ?}
Parameter/ Return parameter	<string> IP address enclosed in double quotes. Eg., 172.16.20.255
Example	:REMOTEDisk:IPADdress "172.16.20.255" Sets the remote disk IP address as 172.16.20.255.

:REMOTEDisk:PATHName
 Set →
 Query

Description	Sets or returns the file path of the remote disk.
Syntax	:REMOTEDisk:PATHName {<string> ?}
Parameter/ Return parameter	<string> File path in enclosed in double quotes eg., "remote_disk"
Example	:REMOTEDisk:PATHName "remote_disk" Sets the file path to c:/remote_disk.

:REMOTEDisk:USERName
 Set →
 Query

Description	Sets or queries the account username for the remote disk.
Syntax	:REMOTEDisk:USERName {<string> ? }

Parameter/Return parameter	<code><string></code>	User name enclosed in double quotes eg., "User_Name".
----------------------------	-----------------------------	---

Example :REMOTEDisk:USERName "User_Name"
Sets the account name as User_Name.

(Set) →

:REMOTEDisk:PASSWord

→ (Query)

Description	Sets or queries the account password for the remote disk.
-------------	---

Syntax	:REMOTEDisk:PASSWord {<string> ? }
--------	--------------------------------------

Parameter/Return parameter	<code><string></code>	Username password enclosed in double quotes eg., "Password".
----------------------------	-----------------------------	--

Example :REMOTEDisk:PASSWord "Password"
Sets the account password as Password.

(Set) →

:REMOTEDisk:MOUNT

→ (Query)

Description	Turns remote disk on/off or queries its state.
-------------	--

Syntax	:REMOTEDisk:MOUNT { OFF ON ? }
--------	------------------------------------

Parameter/Return parameter	OFF	Unmount remote disk
	ON	Mount remote disk

Example :REMOTEDisk:IPADDRESS "172.16.5.154"
:REMOTEDisk:PATHName "remote_disk"
:REMOTEDisk:USERName "guest"
:REMOTEDisk:PASSWord "password"
:REMOTEDisk:MOUNT ON
Sets the remote disk parameters and mounts the remote disk.

:REMOTEDisk:AUTOMount



Description	Turns automount on/off or queries its state. The remote disk must be configured beforehand.	
Syntax	:REMOTEDisk:AUTOMount { OFF ON ? }	
Parameter/Return parameter	OFF	Don't mount the remote disk at start up.
	ON	Automatically mount the remote disk on start up.
Example	:REMOTEDisk:AUTOMount ON Turns the automount function on.	

APPENDIX

Error messages

Description The following error messages may be returned from the :SYSTem:ERRor? query. For details see page 163.

List of error messages	Error number, "Error Description"
	+0, "No error."
	-100, "Command error"
	-101, "Invalid character"
	-102, "Syntax error"
	-103, "Invalid separator"
	-104, "Data type error"
	-105, "GET not allowed"
	-108, "Parameter not allowed"
	-109, "Missing parameter"
	-110, "Command header error"
	-111, "Header separator error"
	-112, "Program mnemonic too long"
	-113, "Undefined header"
	-114, "Header suffix out of range"
	-115, "Unexpected number of parameters"
	-120, "Numeric data error"
	-121, "Invalid character in number"
	-123, "Exponent too large"
	-124, "Too many digits"
	-128, "Numeric data not allowed"
	-130, "Suffix error"
	-131, "Invalid suffix"
	-134, "Suffix too long"
	-138, "Suffix not allowed"

- 140, "Character data error"
- 141, "Invalid character data"
- 144, "Character data too long"
- 148, "Character data not allowed"
- 150, "String data error"
- 151, "Invalid string data"
- 158, "String data not allowed"
- 160, "Block data error"
- 161, "Invalid block data"
- 168, "Block data not allowed"
- 170, "Expression error"
- 171, "Invalid expression"
- 178, "Expression data not allowed"
- 180, "Macro error"
- 181, "Invalid outside macro definition"
- 183, "Invalid inside macro definition"
- 184, "Macro parameter error"

- 200, "Execution error"
- 201, "Invalid while in local"
- 202, "Settings lost due to rtl"
- 203, "Command protected"
- 210, "Trigger error"
- 211, "Trigger ignored"
- 212, "Arm ignored"
- 213, "Init ignored"
- 214, "Trigger deadlock"
- 215, "Arm deadlock"
- 220, "Parameter error"
- 221, "Settings conflict"
- 222, "Data out of range"
- 223, "Too much data"
- 224, "Illegal parameter value"
- 225, "Out of memory"
- 226, "Lists not same length"
- 230, "Data corrupt or stale"
- 231, "Data questionable"
- 232, "Invalid format"
- 233, "Invalid version"
- 240, "Hardware error"

- 241, "Hardware missing"
- 250, "Mass storage error"
- 251, "Missing mass storage"
- 252, "Missing media"
- 253, "Corrupt media"
- 254, "Media full"
- 255, "Directory full"
- 256, "File name not found"
- 257, "File name error"
- 258, "Media protected"
- 260, "Expression error"
- 261, "Math error in expression"
- 270, "Macro error"
- 271, "Macro syntax error"
- 272, "Macro execution error"
- 273, "Illegal macro label"
- 274, "Macro parameter error"
- 275, "Macro definition too long"
- 276, "Macro recursion error"
- 277, "Macro redefinition not allowed"
- 278, "Macro header not found"
- 280, "Program error"
- 281, "Cannot create program"
- 282, "Illegal program name"
- 283, "Illegal variable name"
- 284, "Program currently running"
- 285, "Program syntax error"
- 286, "Program runtime error"
- 290, "Memory use error"
- 291, "Out of memory"
- 292, "Referenced name does not exist"
- 293, "Referenced name already exists"
- 294, "Incompatible type"

- 300, "Device-specific error"
- 310, "System error"
- 311, "Memory error"
- 312, "PUD memory lost"
- 313, "Calibration memory lost"
- 314, "Save/recall memory lost"

- 315, "Configuration memory lost"
- 320, "Storage fault"
- 321, "Out of memory"
- 330, "Self-test failed"
- 340, "Calibration failed"
- 350, "Queue overflow"
- 360, "Communication error"
- 361, "Parity error in program message"
- 362, "Framing error in program message"
- 363, "Input buffer overrun"
- 365, "Time out error"

- 400, "Query error"
- 410, "Query INTERRUPTED"
- 420, "Query UNTERMINATED"
- 430, "Query DEADLOCKED"
- 440, "Query UNTERMINATED after indefinite response"

INDEX

ACQuire	
FILTer	
TRACking	46
ACQuire	
AVERAge	42
FILTer	
FREQuency	46
FILTer	46
SOURce	45
MEMory	43
MODE	43
ACQuire	
STATe	47
ACQuire	
INTERpolation.....	47
ACQuire	
RECORDlength	47
ACQuire	
HEADer.....	48
AUTORSET	
MODE	49
AUTOSet	49
BUS1	172
CAN	
BITRate	182
PROBe	181
SAMPLepoint.....	181
SOURce	181
DISPlay	
FORMAt.....	180
I2C	
ADDRess	
RWINclude.....	173
SCLK	
SOURce.....	174
SDA	
SOURce	174
INPut.....	173
LABel.....	222, 231
DISPlay	223, 225, 231, 232, 233, 234
LIN	
BITRate	183
IDFORmat	183
POLARity	183
SAMPLepoint.....	183
SOURce	184
STANDard	184
SPI	
BITORder.....	178
MISO	
SOURce	179
MOSI	
SOURce	179
SCLK	
POLARity	177
SOURce	178
SS	
POLARity	177
SOURce	179
WORDSize	178
STATE	172
TYPE	172
UART	
BITRate	174
DATABits	175
EOFPAcket	176
PACKEt	175
PARity	175
RX	
SOURce	177
TX	
SOURce	176
CHANnel	
BWLlimit.....	50
COUPLing	51
DESKew	51
DISPlay	51
EXPand.....	52
IMPedance.....	52
INVert	53

LABel	220, 228	DATE.....	170
DISPlay	220, 229	DISPlay	
POStion	53	INTENSity	
PROBE		BACKLight	
TYPE	54	AUTODim	
PROBE		TIME	77
RATio	54	DISPlay	
SCALe	54	GRATicule	78
CLS	38	INTensity	
CURSOR		BACKLight	76
DDT	68	BACKLight	
H1Position	69	AUTODim	
H2Position	69	ENABLE	76
HDELta	70	GRATicule	76
HUNI	67	WAVEform	75
HUSE	67	OUTPut	78
MODE	66	PERSistence	77
SOURce	66	WAVEform	78
V1Position	70	DVM	
VDELta	71	MODE	246
VUNI	68	SOURce	245
VUSE	68	STATE	245
XY		VALue	246
POLar		Error list	278
RADIUS		Ethernet	
DELta	73	interface	8
POStion	72	ETHERnet	
THETA		DHCP	169
DELta	73	FORCe	118
POStion	73	GONogo	
PRODuct		CLEar	247
DELta	74	EXECute	247, 254
POStion	74	FUNction	248, 254
RATio		NGCount	248, 255, 256, 257, 258,
DELta	75	259, 260, 261, 262, 263, 264, 265,	
RATio		266, 267, 268, 269, 270	
POStion	74	NGDefine	248
RECTangular		SCRipt	249
X		SOURce	249
DELta	71	VIOLation	249
POStion	71	HARDcopy	
Y		ASSIGN	81
DELta	72	MODE	79
POStion	72	PRINTINKSaver	80
DATALOG			
DURation	274		
INTerval	273		
SAVe	273		
SOURce	272		
STATE	272		

WAVEform.....	164	Identifier	
REF		DIRection	210
DISPlay	114	MODE	209
LABEL	221, 229	VALue	210
DISPlay.....	221, 223, 230	I2C	
OFFSet.....	115	ADDRESS	
SCALE.....	116	DIRection	200
TIMEbase		MODE	198
POSITION	114	TYPE.....	198
SCALE.....	115	VALue	199
Remote control		CONDition	197
interface configuration.....	5	DATA	
REMOTEDisk		SIZE.....	200
AUTOMount.....	277	VALue	201
IPADDRESS.....	275	LIN	
MOUNT.....	276	CONDition	213
PASSWORD.....	276	DATA	
PATHName.....	275	QUALifier	214
USERName.....	275	SIZE.....	215
RST.....	38	VALue	215
RUN.....	117	ERRTYPE	216
SAV.....	37	IDENTifier	
SAVE		VALue	217
IMAGE	165	SPI	
FILEFormat.....	165	CONDition	205
INKSaver.....	166	DATA	
SETUp.....	166	MISO.....	206
WAVEform.....	167	MOSI.....	207
FILEFormat.....	168	SIZE.....	206
SEARCH		UART	
COPY	188	CONDition	202
FFTPeak		RX	
METHod	217	DATA	203
MPEak.....	218	TX	
SINFo.....	219	DATA	204
STATE	189	TYPE	197
TOTAL.....	189	EDGE	
TRIGger		SLOP.....	190
BUS		HLEVel	191
B1		LEVel	191
CAN		LLEVel.....	192
CONDition.....	208	PULSe	
DATA		TIME	194
QUALifier	211	WHEN.....	194
SIZE.....	212	PULSEWidth	
VALue	212	POLarity.....	192
FRAMEType	209	RISEFall	
		SLOP.....	193
		TIME	196
		WHEN.....	196
		RUNT	
		POLarity	193
		TIME	195
		WHEN.....	195
		SOURce.....	190
		TYPE.....	189

SEGMENTS		TIMEbase	
CURRent	237	EXPand.....	119
DISPAll	238	MODE.....	120
MEASure		POSition	119
MODE.....	238	SCALe	119
PLOT		WINDow	
DIVide.....	239	POSition.....	120
RESults.....	240	SCALe.....	121
SELect	240		
SOURce.....	239	TRIGger	
TABLe		ALTErnate.....	137
LIST	242	BUS	
SAVe	242	B1	
SELect	241	CAN	
SOURce.....	241	CONDition.....	150
SAVe	242	DATA	
SELect		QUALifier	152
END	244	SIZE.....	153
START.....	243	VALue.....	154
SOURce	243	FRAMeType	150
STATE.....	236	IDentifier	
TIME.....	238	DIRection.....	152
TOTalnum.....	237	MODE.....	151
		VALue.....	151
SET		I2C	
LABel	223, 235	ADDRESS	
SINGLE.....	117	DIRection.....	142
Socket server		MODE.....	141
function check.....	11	TYPe	141
Socket server		VALue	142
interface.....	10	CONDition	140
STOP	117	DATA	
SYSTEM		SIZE.....	143
ERRor.....	163	VALue.....	143
LOCK.....	163	LIN	
TEMPLATE		CONDition	154
MAXimum	250	DATA	
MINimum	250	QUALifier	155
MODE.....	250	SIZE.....	156
POSition		VALue	156
MAXimum	251	ERRTYPE....	157, 158, 159, 160,
MINimum	251	161	
SAVe		IDentifier	
AUTO.....	252	VALue.....	158
MAXimum	251	SPI	
MINimum	252	CONDition	147
TOLerance.....	252	DATA	
		MISO	
		VALue	148
		MOSI	
		VALue	149
		SIZE.....	148
		UART	
		CONDition.....	144
		RX	

DATA	
SIZE.....	145
VALue	145
TX	
DATA	
SIZE.....	146
VALue	146
THReshold	
CH.....	140
TYPe	139
COUPle.....	125
DELay	
EVENT.....	130
LEVel	130
SLOP.....	128
TIME.....	129
TYPe.....	129
EDGE	
SLOP.....	128
EXTERnal	
PRObe	
RATio.....	139
TYPe.....	138
FREQuency.....	124
HLEVel	127
HOLDoff.....	126
LEVel.....	127
LLEVel	128
MODE.....	126
NREJ.....	126
PULSe	
TIME	136
WHEn.....	135
PULSEWidth	
POLarity	130
RISEFall	
SLOP	132
Time.....	133
WHEn.....	132
RUNT	
POLarity	131
Time.....	132
WHEn.....	131
SOURce	125
STATe.....	138
TIMEOut	
TIMER.....	137
WHEn.....	136
TYPe.....	124
VIDeo	
FIEld	134
LINE	135
POLarity	135
TYPe.....	134
USB	
function check	6
remote control interface	5