



## SBS-H2

### Hydrogen Gas Detector Kit

*For battery charging rooms and other areas where hydrogen gas may be present*

# INSTALLATION, OPERATING & MAINTENANCE INSTRUCTIONS



**Protects Life, Property, and Profits**

*Compliant with NFPA 70E<sup>®</sup> and IEEE Recommendations*

**1-800-554-2243**

[www.sbsbattery.com](http://www.sbsbattery.com)

■ [Test@sbsbattery.com](mailto:Test@sbsbattery.com)

## Table of Contents:

<b>Description</b>	<b>Page</b>	<b>Section</b>
<i>Overview</i>	<b>3</b>	<b>1.0</b>
<i>Benefits</i>	<b>3</b>	<b>2.0</b>
<i>How It Works</i>	<b>3</b>	<b>3.0</b>
<i>Specifications</i>	<b>4</b>	<b>4.0</b>
<i>Sensor</i>	<b>4</b>	<b>5.0</b>
<i>Mounting Location</i>	<b>5</b>	<b>6.0</b>
<i>Installation</i>	<b>6</b>	<b>7.0</b>
<i>Operation</i>	<b>9</b>	<b>8.0</b>
<i>Electrical Testing</i>	<b>9</b>	<b>9.0</b>
<i>Sensor Testing</i>	<b>10</b>	<b>10.0</b>

## Part Numbers & Options:

<b><u>Part No.</u></b>	<b><u>Description</u></b>
<b>SBS-H2</b>	Hydrogen Gas Detector (Includes: Main Unit, (1) sensor & (1) 25ft cable)
<b>H2-JB</b>	Junction Box, 4 11/16" X 4 11/16" Metal, with Knockouts
<b>H2-SENSOR-25ft</b>	Additional/Replacement Hydrogen Gas Sensor with 25ft cable
<b>H2-SENSOR-50ft</b>	Additional/Replacement Hydrogen Gas Sensor with 50ft cable
<b>H2-SENSOR-100ft</b>	Additional/Replacement Hydrogen Gas Sensor with 100ft cable
<b>H2-TESTKIT</b>	Field Test Kit for SBS-H2 Sensor
<b>E190399</b>	110vac 3 Prong AC Cord, 10 Ft., 18AWG

## Warnings:

- This detector is added protection, not a substitute for prudent safety measures, where hydrogen gas is present. For large or highly-sensitive areas, you may have to use two or more detectors with 1 to 3 sensors each for increased coverage area.
- The hydrogen sensor does not provide protection from fires or hydrogen explosions. The relay contacts are intended to be connected to a safety system, enabling audible alarms, system shutdown, ventilation, or other measures to ensure safe handling and use of hydrogen gas.
- Ensure that your installation complies completely with all relevant Local, State, Federal, and OSHA safety and health regulations.
- If sensor responds, there is a risk of combustion or explosion. To avoid injury, leave area immediately.
- The hydrogen sensor is calibrated for operation in air. Tampering with the sensor or operation in other gas environments can lead to inaccurate readings and possible permanent damage if operating in a reducing atmosphere or 100% hydrogen. The hydrogen sensor is silicone resistant but uncured silicone compounds or extended exposure to silicone off gassing, or high concentrations of refrigerant gasses related to a leak, can give inaccurate readings in the sensor.

## 1.0 Overview

Hydrogen gas detectors act as monitors that provide alarms as well as control functions such as controlling exhaust fans, remote alarm and signaling, building management interfacing and more for the protection of your facility. Batteries on charge emit hydrogen gas as part of the chemical reaction of recharge.

**Concentrations of 4.1% to 75% H<sub>2</sub> mixed with air can be explosive.** Sparks or hot surfaces can ignite them. A hydrogen gas detector in your battery room will provide a warning and facilitate dissipation of hydrogen concentrations before they reach the lower explosive limit (LEL) of 4.1%.

## 2.0 Benefits

In addition to protecting your employees and your property, the detector may also reduce the following costs:

### Electricity - Heating - Air Conditioning

Instead of continuously running an exhaust fan to prevent hydrogen gas accumulation, use the detector to activate the fan only if the concentration reaches 1%.

### Insurance

Installation of a detector in areas where batteries are charged may result in a premium reduction.

## 3.0 How it Works

Should the concentration of hydrogen gas in the air surrounding the sensor reach 1% by volume, the "1% Warning" yellow LED will light and the 1% internal relay will energize. Should the hydrogen gas concentration reach 2% by volume, the "2% Alarm" red LED will flash, the strobe will flash and an alarm will sound. Either relay can be used to activate a remote exhaust fan and/or provide a dry contact closure for signaling, control or monitoring. Please review the ratings for each relay.

The SBS-H2 provides automatic operation, continuous monitoring, high sensitivity and stability, and solid state reliability. The unit uses 120/240 VAC 50/60 Hz or 12-58 VDC operating voltages, is low in cost, and easy and versatile to install.

## 4.0 Specifications

### Dimensions:

- 4.7"L x 4.7"W x 1.2"D (display only)

### Wall Mounting:

- Two 3/16" screws

### Junction Box Mounting:

- Requires 4 11/16" x 4 11/16" 2-gang junction box (**SBS Part# H2-JB**)

### Power Requirements:

- 120/220 VAC, 50/60 Hz **or**
- 12VDC Isolated or 14 to 58 VDC **NOTE: An earth ground must be supplied to the GND terminal on the AC terminal block when using the DC supply to the unit.**

### Relays:

- 1% Warning Relay, 1 Normally Open & 1 Normally Closed contact
- 2% Alarm Relay, 1 Normally Open and 1 Normally Closed contact

## 5.0 Sensor

The sensor consists of an electronic sensing element whose electrical conductivity increases when hydrogen is detected at its surface. Conductivity of the sensor is proportional to the gas concentration which is continuously monitored by the electronic alarm circuits. The sensor only monitors for hydrogen gas (H<sub>2</sub>) and will not alarm due to Hydrogen Sulfide (H<sub>2</sub>S) – which has an odor at very low concentrations.



**Hydrogen Sensor**



**25 Ft. Cable Extension**

## 6.0 Mounting Location

Hydrogen is colorless and odorless, the lightest of all gases, and thus rises. The Hydrogen Sensor, therefore, should be installed at the highest, draft-free location in the battery compartment, cabinet, or room where hydrogen gas would accumulate.

The Alarm Box can be mounted at eye level or wherever is convenient for the user.

The size of the area one sensor will protect depends upon the battery compartment or room. The detector measures hydrogen gas concentration in the air immediately surrounding the sensor. Hydrogen gas may accumulate in several areas of the battery compartment or room; therefore, individual sensors should be installed in each of these areas.

### Mounting and Power Options:



#### Wall Mountable

Integrated back mounting plate allows user to easily mount directly to any wall using (qty. 2) 3/16" screws (not included).

#### Wiring

Power and Alarm Wires can be run through the sides of the unit



#### Junction Box Mountable

Mounts to a standard, 4 11/16" x 4 11/16" 2-gang junction box (SBS Part# H2-JB).



**Hardwire**

Run AC or DC power and alarm wires through back of the unit, into the gang box and out through conduit.



**AC Cord -not included**  
**(SBS Part# E190399)**

Unit shown with 3-prong grounded AC Cord (18+ AWG)

## 7.0 Installation

Hydrogen gas has only 7% of the density of air and thus rises. Your hydrogen gas detector should be installed at the highest, draft-free location in the battery room, cabinet, or compartment where hydrogen gas would accumulate.

Carefully remove the cover by pulling it off the detector. Attach the detector to the wall, ceiling, or optional junction box using the mounting holes at the top and bottom of the detector mounting plate.

For hard wiring using conduit, the detector box will fit onto the optional junction box.

The detector has terminal blocks for connection to a single-phase 120 VAC 50/60 Hz power source, OR a +12 VDC - 58 VDC power source. The power supply inputs are redundant so the unit can use the DC input as a back up source. It also has two internal alarm relays, a 1% warning relay that is activated at 1% concentration of hydrogen gas and a 2% alarm relay that is energized at 2% concentration of hydrogen gas. The relays can be used to switch on a remote exhaust fan and/or to turn on an alarm.

For 120 VAC power, use 18 gage stranded wire minimum. For relay wires, use stranded wire. Maximum wire size for connector terminations is **14 AWG** stranded copper wire.

The detector's **1% warning relay** dry contacts are rated at 10A/250VAC, sufficient for most 1/3 HP exhaust fans. The 2% alarm relay dry contact is rated for 1A/30 VDC and 0.5A/125VAC. *Note: For higher current requirements, add an external relay.*

Locate the Sensor installation point within 25 feet, 50 ft. or 100 ft. of the detector, based on cable length, and mount the sensor. Run the supplied cable from the sensor to the detector and connect to the Sensor 1 input (labeled on the cover).

## For Installation of Additional Sensors

A maximum of three (3) sensors may be added to each alarm module. Multiple detectors can be installed to meet the space coverage requirements of your particular installation.

Locate the additional sensors installation points within 100 feet of the detector and mount the sensor. Connect the cables from the added sensors to the Sensor 2 and Sensor 3 inputs.

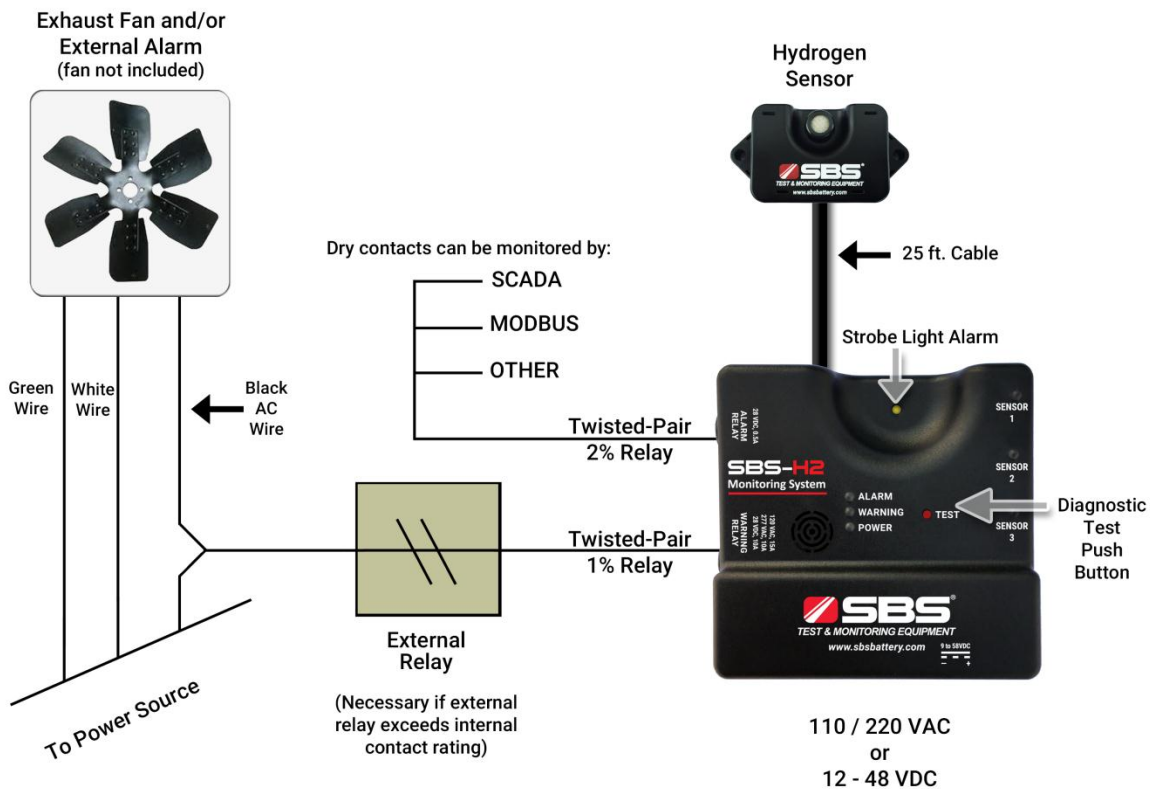

The detector has 2 internal relays. One relay energizes when the sensor detects a 1% concentration of hydrogen gas in the air surrounding it. The second relay contact energizes at a 2% concentration. The detector's 1% internal relay is rated: 15 amps at 120 volts AC; 10 amps at 250 volts AC; 10 amps at 30 volts DC; 1/3 horsepower at 125 volts AC; 1/2 horsepower at 250 volts AC. The 2% internal relay is rated: 1 amps at 30 volts DC and 0.5A and 125 volts AC.

*Note: If the load you have is higher than these relay ratings, add an external relay (shaded item in the sketch above).*

## Alarm System Electronics:

Please refer to the illustration below showing proper power and relay connection points in the detector. It is advisable to use a pair of 14 gage or smaller stranded wire for the relay contacts to help reduce any interference within the battery room that may cause false alarms.

Each of the Cat5 sensor input connections has a status indicator light which will display solid green when a sensor is connected and operating normally. During a warning or alarm condition, the sensor location which is sensing the 1% or 2% H<sub>2</sub> concentration will flash at the same rate as the yellow or red LED's of the Alarm Box status indicators.

A sensor fault is indicated by a flashing sensor status LED without a matching alarm box flashing condition.

## Terminal Connection Diagram:

### SBS-H2 WIRING POINT REFERENCE

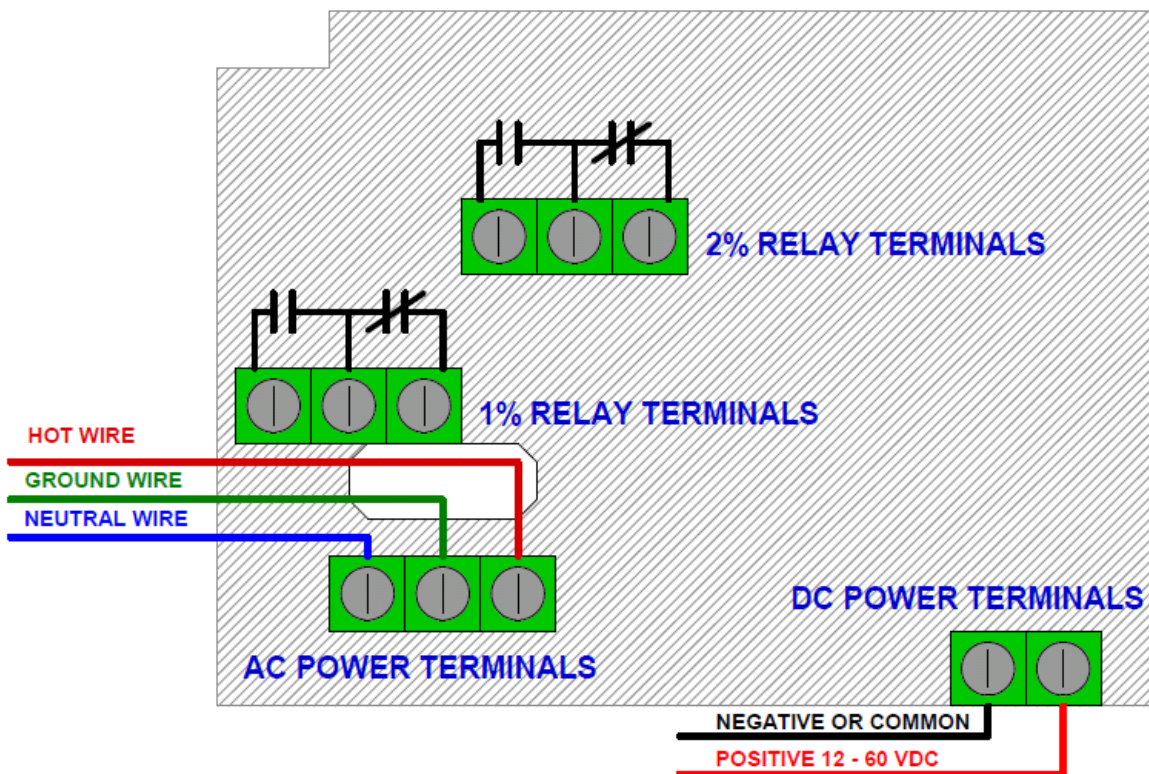



## Using the Mechanical Relays:

1. Remove the front cover of the detector by pulling straight off the body. This will reveal the inner electronics of the alarm box.
2. Locate the terminal blocks for the relays and determine which condition you would like to use the relay to be related to. Use the 1% Relay (1% H<sub>2</sub>) for the warning condition and the 2% relay (2% H<sub>2</sub>) for the alarm condition.
3. Replace the front cover on the alarm box.

## 8.0 Operation

Keep the detector on at all times. A solid green LED indicates that the detector is powered on.

**When power is first turned on, a warm up period of 30 seconds will elapse before the detector will start to function. This delay is to prevent false activation of the internal relays and alarm.**

If the concentration of hydrogen gas in the air surrounding the sensor reaches 1% by volume, the yellow LED will light and the 1% internal relay will energize (which can be used to activate a remote fan and/or alarm).

Should the concentration reach 2%, the red LED will illuminate, the audible warning alarm will sound, the strobe alarm light will flash, and the 2% internal relay will energize. The 1% relay will remain energized and the yellow LED will remain on.

When the concentration decreases below 2%, the red LED will turn off, the internal alarm will stop, the strobe will turn off, and the 2% relay will de-energize. When the concentration falls below 1%, the 1% relay will de-energize and the yellow LED will turn off.

## 9.0 Electrical Testing

A "TEST" button is located on the front of the unit. Push and hold this button for approximately 10 seconds to test the unit's electronic circuitry.

The caution and warning LEDs will light in sequence; the strobe will flash, the relays will activate whatever is connected to them and the internal warning alarm will sound.

**Note: The "TEST" button does NOT test the sensor(s) itself.**

## 10.0 Testing Sensor Calibration

The sensor and display have been calibrated at the factory for hydrogen gas and should not need adjustment at the time of installation.



***SBS Test Kit – Part# H2-TESTKIT***

The Test kit is intended for periodic testing of the functionality of the sensors and proper operation of the system. Once the sensor is installed, calibration or adjustment of the sensor is not possible. Please contact your sales representative if sensor calibration is desired or required.

The information in this sheet has been carefully reviewed and is believed to be accurate; however, no responsibility is assumed for inaccuracies. Storage Battery Systems, LLC. reserves the right to make changes without further notice to any product, datasheet, technical data bulletin, or website.

Storage Battery Systems, LLC. makes no warranty, representation of guarantee regarding the suitability of its product for any particular purpose, nor does Storage Battery Systems, LLC. assume any liability arising out of the application or use of any product and specifically disclaims any and all liability, including without limitation consequential or incidental damages. "Typical" parameters can and do vary in different applications. All operating parameters, including "Typical" must be validated for each customer application by customer's technical experts.

Storage Battery Systems, LLC. products are not designed, intended, or authorized for use as components in systems intended for surgical implant into the body, or other application intended to support or sustain life, or for any application in which the failure of the SBS product could create a situation where personal injury or death may occur.

Should buyer purchase or use SBS products for any such unintended or unauthorized application, Buyer shall indemnify and hold Storage Battery Systems, LLC. and its officers, employees, subsidiaries, affiliates, and distributors harmless against all claims, costs, damages, and expenses, and reasonable attorney fees arising out of, directly or indirectly, any claim of personal injury or death associated with such unintended or unauthorized use, even if claim alleges that Storage Battery Systems, LLC. was negligent regarding the design or manufacture of the part.

In the case of a defect in the sensor, Storage Battery Systems, LLC. shall not be liable for any damages which may result, including, but not limited to, loss of revenue, property, or life. In an event, Storage Battery Systems, LLC. shall limit liability to replacement of the defective unit. Storage Battery Systems, LLC. does not convey any license under its patent rights nor the rights of others.



N56 W16665 Ridgewood Drive  
Menomonee Falls, WI 53051

03-16-TIOMH2

**1-800-554-2243**

**[www.sbsbattery.com](http://www.sbsbattery.com)**

**[Test@sbsbattery.com](mailto:Test@sbsbattery.com)**