

Features

- Loop-powered, 4 to 20 mA transmitter
- Fast response planar aluminum oxide sensor
- Integral filtering and flow regulation
- Trouble-free indoor or outdoor mounting
- Field validation with the MMY245 moisture analyzer
- Microcontroller electronics in Type 4X/IP67 enclosure

Options

- Integrated display with user interface
- FM approved intrinsically safe/explosion-proof, Class I,II,III, Division 1 and 2, Groups A,B,C,D,E,F&G hazardous (classified) locations
- English or metric fittings
- External display available with loop-powered supply and alarm contacts

The DewPro MMY30 is a loop-powered transmitter with 4 to 20 mA output. The DewPro MMY30 is specifically designed to measure dew point or ppm in gases at line pressure or atmospheric pressure. The planar aluminum oxide sensor provides excellent corrosion resistance, longer calibration stability, quick response times, and an exceptionally low temperature coefficient. The optional integrated display with user interface provides full programming and diagnostic capability.

The DewPro MMY30 features an integral flow cell for filtration and flow regulation making it ideal for monitoring the moisture content in various process environments. Several options are available for the process connection allowing easy installation of the transmitter. Applications include desiccant air dryers, pipeline natural gas and industrial gases.

DewPro[®] MMY30

Dew Point Transmitter

DewPro MMY30 is a General Eastern product. General Eastern has joined other GE high-technology sensing businesses under a new name—GE Industrial, Sensing.



DewPro MMY30 Specifications

Sensing Element

Planar aluminum oxide sensor

Measurement Range

-130°F to 50°F (-90°C to 10°C) dew point temperature;
0 to 10, 0 to 100, 0 to 1000 ppm_v (fully adjustable with
integral display)

Recommended Recalibration Cycle

12 months, depending on the application

Calibration Accuracy

±3.6°F (±2°C) dew point at 77°F (25°C)

Maximum Sensor Relative Humidity

50% at dew point temperature > 32°F (0°C)

Operating and Storage Temperature

Process: -40°F to 122°F (-40°C to 50°C)
Electronics: -40°F to 185°F (-40°C to 85°C)

Air Bleed Off at 100 psig (7 bar)

Approximately 1 SCFH (28 sl/h)

Maximum Operating Pressure

450 psig (31 bar, 3.1 MPa)
Inlet filter: 2 micron sintered stainless steel

Helium Leak-Rate

<10⁻⁶ mbar 1/s

Output

4 to 20 mA loop-powered, 16 µA resolution

Flow Block

316 stainless steel with 1/2 in MNPT or G 1/2 thread
(DIN ISO 228)

Wrench Width for Flow Block

1-5/8 in (42 mm)

Electronics

Microcontroller operated

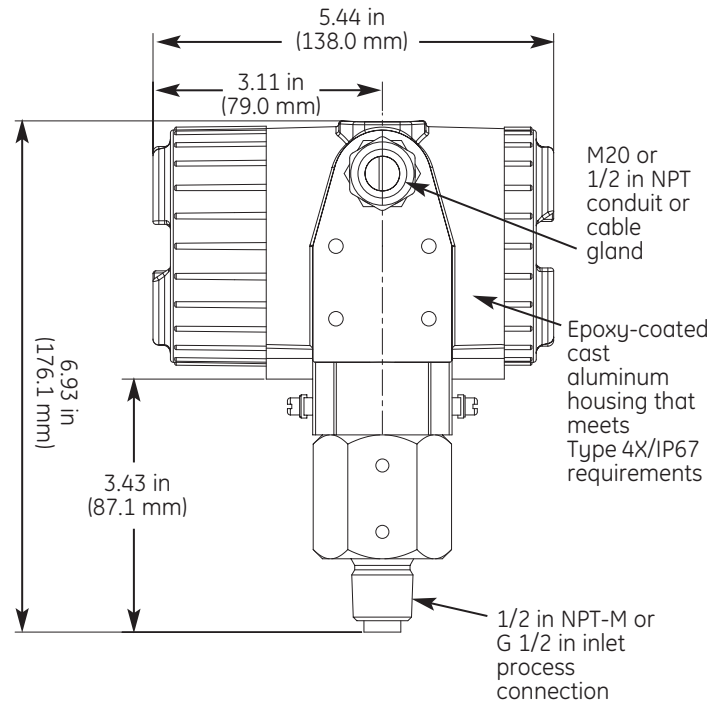

DewPro MMY30 with display option

Optional Display

Four-digit numeric display with bar graph and matrix position indication. Four user interface keys for unit selections, output adjustments and ranging.

Power Supply

24 VDC nominal, 12 to 30 VDC range

Protection

Type 4X/IP67

Weight

4.4 lb (2 kg)

European Compliance

Complies with EMC Directive 89/336/EEC and PED 97/23/EC for DN<25

Optional Certifications/Approvals

- FM IS Class I,II,III, Division 1, Groups A,B,C,D,E,F&G, T5
- FM XP-IS Class I, Division 1, Groups A,B,C&D, T5
- FM NI Class I, Division 2, Groups A,B,C&D, T4A
- DIP Class II,III, Division 1, Groups E,F&G, T5
- ATEX II 3G EEx nA IIC T4



©2005 GE. All rights reserved.
920-064A

TRANSCAT

▶ Visit us at Transcat.com!

35 Vantage Point Drive // Rochester, NY 14624 // Call 1.800.800.5001

All specifications are subject to change for product improvement without notice.
DewPro® is a registered trademark of GE. GE® is a registered trademark of General Electric Co.