

# Keysight P9241/42/43A Oscilloscopes

# Notices

© Keysight Technologies, Inc. 2005-2018

No part of this manual may be reproduced in any form or by any means (including electronic storage and retrieval or translation into a foreign language) without prior agreement and written consent from Keysight Technologies, Inc. as governed by United States and international copyright laws.

## Manual Part Number

P9241-97001

## Edition

First edition, February 2018

Available in electronic format only

Published by:  
Keysight Technologies, Inc.  
1900 Garden of the Gods Road  
Colorado Springs, CO 80907 USA

## Print History

P9241-97001, February 2018

## Warranty

**The material contained in this document is provided "as is," and is subject to being changed, without notice, in future editions. Further, to the maximum extent permitted by applicable law, Keysight disclaims all warranties, either express or implied, with regard to this manual and any information contained herein, including but not limited to the implied warranties of merchantability and fitness for a particular purpose. Keysight shall not be liable for errors or for incidental or consequential damages in connection with the furnishing, use, or performance of this document or of any information contained herein. Should Keysight and the user have a separate written agreement with warranty terms covering the material in this document that conflict with these terms, the warranty terms in the separate agreement shall control.**

## Technology License

The hardware and/or software described in this document are furnished under a license and may be used or copied only in accordance with the terms of such license.

## U.S. Government Rights

The Software is "commercial computer software," as defined by Federal Acquisition Regulation ("FAR") 2.101. Pursuant to FAR 12.212 and 27.405-3 and Department of Defense FAR Supplement ("DFARS") 227.7202, the U.S. government acquires commercial computer software under the same terms by which the software is customarily provided to the public. Accordingly, Keysight provides the Software to U.S. government customers under its standard commercial license, which is embodied in its End User License Agreement (EULA), a copy of which can be found at [www.keysight.com/find/sweula](http://www.keysight.com/find/sweula). The license set forth in the EULA represents the exclusive authority by which the U.S. government may use, modify, distribute, or disclose the Software. The EULA and the license set forth therein, does not require or permit, among other things, that Keysight: (1) Furnish technical information related to commercial computer software or commercial computer software documentation that is not customarily provided to the public; or (2) Relinquish to, or otherwise provide, the government rights in excess of these rights customarily provided to the public to use, modify, reproduce, release, perform, display, or disclose commercial computer software or commercial computer software documentation. No additional government requirements beyond those set forth in the EULA shall apply, except to the extent that those terms, rights, or licenses are explicitly required from all providers of commercial computer software pursuant to the FAR and the DFARS and are set forth specifically in writing elsewhere in the EULA. Keysight shall be under no obligation to update, revise or otherwise modify the Software. With respect to any technical data as defined by FAR 2.101, pursuant to FAR 12.211 and 27.404.2 and DFARS 227.7102, the U.S. government acquires no greater

than Limited Rights as defined in FAR 27.401 or DFAR 227.7103-5 (c), as applicable in any technical data.

## Safety Notices

This product has been designed and tested in accordance with accepted industry standards, and has been supplied in a safe condition. The documentation contains information and warnings that must be followed by the user to ensure safe operation and to maintain the product in a safe condition.

### CAUTION

A **CAUTION** notice denotes a hazard. It calls attention to an operating procedure, practice, or the like that, if not correctly performed or adhered to, could result in damage to the product or loss of important data. Do not proceed beyond a **CAUTION** notice until the indicated conditions are fully understood and met.

### WARNING

A **WARNING** notice denotes a hazard. It calls attention to an operating procedure, practice, or the like that, if not correctly performed or adhered to, could result in personal injury or death. Do not proceed beyond a **WARNING** notice until the indicated conditions are fully understood and met.

## Keysight P9241/42/43A Oscilloscopes—At a Glance

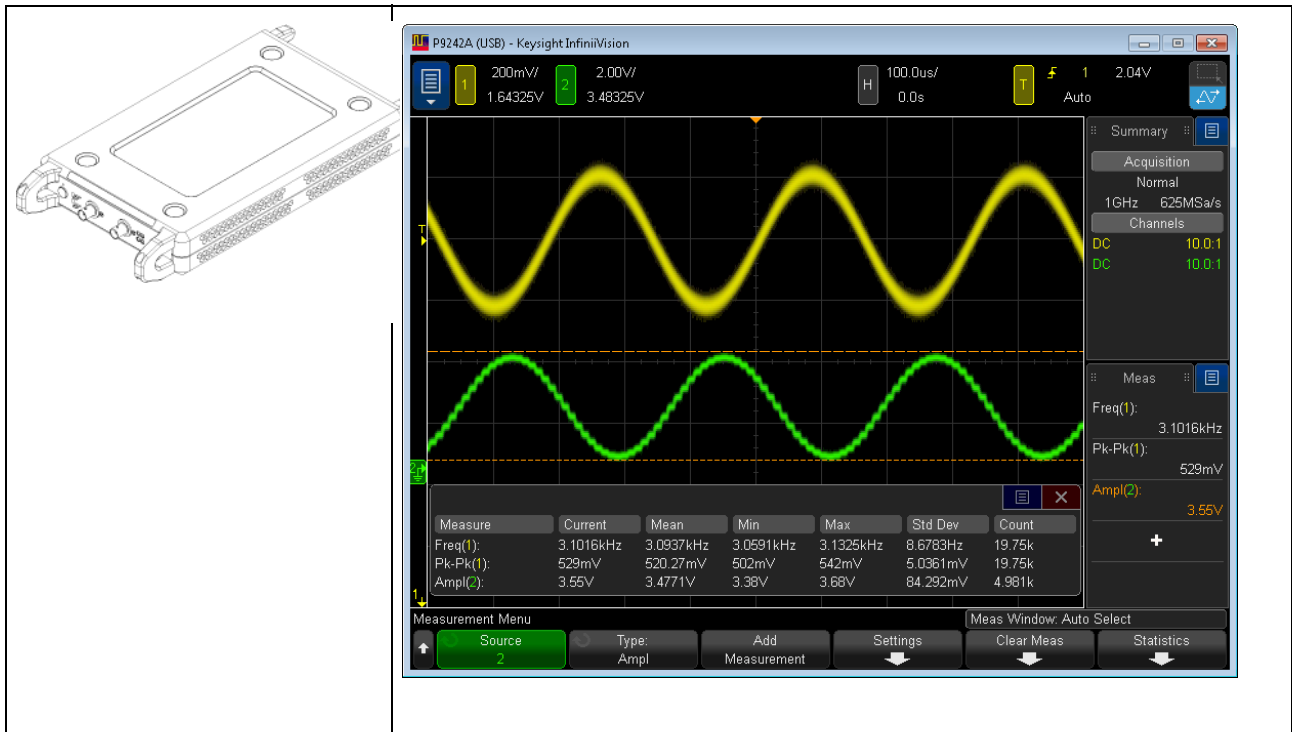

**Table 1** Keysight P9241/42/43A Oscilloscope Models, Band widths, Sample Rates

Band width	200 MHz	500 MHz	1 GHz
Sample Rate	5 GSa/s	5 GSa/s	5 GSa/s
2-Channel DSO	P9241A	P9242A	P9243A

The Keysight P9241/42/43A oscilloscopes deliver these features:

- 200 MHz, 500 MHz, and 1 GHz bandwidth models.
- 2-channel digital storage oscilloscope (DSO) models.
- Interleaved 4 Mpts or non-interleaved 2 Mpts MegaZoom IV memory for the fastest waveform update rates, uncompromised.
- Trigger types: edge, edge then edge, pulse width, pattern, OR, rise/fall time, Nth edge burst, runt, setup & hold, video, NFC, and zone.
- Serial decode/trigger options for: CAN/CAN FD/LIN, CXPI, FlexRay, I<sup>2</sup>C, Manchester/NRZ, MIL-STD-1553/ARINC 429, SENT, and UART/RS232, and USB PD. There is a Lister for displaying serial decode packets.
- Math waveforms: add, subtract, multiply, divide, d/dt, integrate, FFT (Magnitude), FFT (Phase), Ax+B, square, square root, absolute value, common logarithm, natural logarithm, exponential, base 10 exponential, low pass filter,

high pass filter, averaged value, smoothing, envelope, magnify, maximum, minimum, peak-peak, max hold, min hold, and measurement trend.

- Reference waveform locations (2) for comparing with other channel or math waveforms.
- Many built-in measurements and a measurement statistics display.
- Built-in, license-enabled 1-channel waveform generator with: arbitrary, sine, square, ramp, pulse, DC, noise, sine cardinal, exponential rise, exponential fall, cardiac, and Gaussian pulse. Modulated waveforms on WaveGen except for arbitrary, pulse, DC, and noise waveforms.
- A Quick Help system is built into the oscilloscope. Click and hold the mouse button over any softkey label button to display Quick Help. Complete instructions for using the quick help system are given in "**Access the Built-In Quick Help**" on page 21.

For more information about InfiniiVision oscilloscopes, see:

[www.keysight.com/find/scope](http://www.keysight.com/find/scope)

## In This Guide

This guide shows how to use the P9241/42/43A oscilloscope's Soft Front Panel (SFP) user interface.

When first using the Soft Front Panel (SFP) user interface, see:	<ul style="list-style-type: none"> <li>▪ <a href="#">Chapter 1</a>, “Getting Started,” starting on page 19</li> </ul>
When displaying waveforms and acquired data, see:	<ul style="list-style-type: none"> <li>▪ <a href="#">Chapter 2</a>, “Horizontal Controls,” starting on page 35</li> <li>▪ <a href="#">Chapter 3</a>, “Vertical Controls,” starting on page 51</li> <li>▪ <a href="#">Chapter 4</a>, “Math Waveforms,” starting on page 65</li> <li>▪ <a href="#">Chapter 5</a>, “Reference Waveforms,” starting on page 97</li> <li>▪ <a href="#">Chapter 6</a>, “Serial Decode,” starting on page 105</li> <li>▪ <a href="#">Chapter 7</a>, “Display Settings,” starting on page 111</li> <li>▪ <a href="#">Chapter 8</a>, “Labels,” starting on page 123</li> </ul>
When setting up triggers or changing how data is acquired, see:	<ul style="list-style-type: none"> <li>▪ <a href="#">Chapter 9</a>, “Triggers,” starting on page 129</li> <li>▪ <a href="#">Chapter 10</a>, “Trigger Mode/Coupling,” starting on page 169</li> <li>▪ <a href="#">Chapter 11</a>, “Acquisition Control,” starting on page 177</li> </ul>
Making measurements and analyzing data:	<ul style="list-style-type: none"> <li>▪ <a href="#">Chapter 12</a>, “Cursors,” starting on page 195</li> <li>▪ <a href="#">Chapter 13</a>, “Measurements,” starting on page 203</li> <li>▪ <a href="#">Chapter 14</a>, “Mask Testing,” starting on page 235</li> <li>▪ <a href="#">Chapter 15</a>, “Digital Voltmeter and Counter,” starting on page 249</li> <li>▪ <a href="#">Chapter 16</a>, “Frequency Response Analysis,” starting on page 255</li> </ul>
When using the built-in license enabled waveform generator, see:	<ul style="list-style-type: none"> <li>▪ <a href="#">Chapter 17</a>, “Waveform Generator,” starting on page 261</li> </ul>
When saving or recalling, see:	<ul style="list-style-type: none"> <li>▪ <a href="#">Chapter 18</a>, “Save/Email/Recall (Setups, Screens, Data),” starting on page 281</li> </ul>
When using the oscilloscope's utility functions or web interface, see:	<ul style="list-style-type: none"> <li>▪ <a href="#">Chapter 19</a>, “Utility Settings,” starting on page 293</li> </ul>

For reference information, see:	<ul style="list-style-type: none"> <li>▪ <a href="#">Chapter 20</a>, “Reference,” starting on page 305</li> </ul>
When using licensed serial bus triggering and decode features, see:	<ul style="list-style-type: none"> <li>▪ <a href="#">Chapter 21</a>, “CAN/LIN Triggering and Serial Decode,” starting on page 321</li> <li>▪ <a href="#">Chapter 22</a>, “CXPI Triggering and Serial Decode,” starting on page 343</li> <li>▪ <a href="#">Chapter 23</a>, “I2C Triggering and Serial Decode,” starting on page 353</li> <li>▪ <a href="#">Chapter 24</a>, “Manchester/NRZ Triggering and Serial Decode,” starting on page 363</li> <li>▪ <a href="#">Chapter 25</a>, “MIL-STD-1553/ARINC 429 Triggering and Serial Decode,” starting on page 381</li> <li>▪ <a href="#">Chapter 26</a>, “SENT Triggering and Serial Decode,” starting on page 397</li> <li>▪ <a href="#">Chapter 27</a>, “UART/RS232 Triggering and Serial Decode,” starting on page 409</li> <li>▪ <a href="#">Chapter 28</a>, “USB PD Triggering and Serial Decode,” starting on page 419</li> </ul>

**TIP**

**Abbreviated instructions for selecting menus and softkeys**

Instructions for selecting a series of menus and softkey label buttons are written in an abbreviated manner. Instructions for selecting **Menu Item1**, **Menu Item2**, then **Softkey1** and **Softkey2** are abbreviated as follows:

Choose **Main Menu > Menu Item1 > Menu Item2 > Softkey1 > Softkey2**.

Softkey label buttons are the six buttons located at the bottom of the Soft Front Panel oscilloscope display.

# Contents

Keysight P9241/42/43A Oscilloscopes—At a Glance / 3

In This Guide / 5

## 1 Getting Started

See the Startup Guide / 20

Using the Soft Front Panel (SFP) Interface / 21

    Access the Built-In Quick Help / 21

    Select the User Interface Language / 22

Differences Between USB and Benchtop Oscilloscopes / 23

Learn the Mouse Controls / 24

    Access Controls and Menu Using the Main Menu Icon / 24

    Draw Rectangles for Waveform Zoom or Zone Trigger Set Up / 26

    Drag to Scale, Position, and Change Offset / 26

    Select Sidebar Information or Controls / 27

    Undock Sidebar Dialog Boxes by Dragging / 28

    Re-dock Sidebar Dialog Boxes to a Split Sidebar / 29

    Select Dialog Box Menus and Close Dialog Boxes / 29

    Drag Cursors / 29

    Click Softkeys and Menus On the Screen / 30

    Enter Names Using Alpha-Numeric Keypad Dialog Boxes / 30

    Change Waveform Offsets By Dragging Ground Reference Icons / 31

    Turn Channels On/Off and Open Scale/Offset Dialog Boxes / 31

    Access the Horizontal Menu and Open the Scale/Delay Dialog Box / 32

    Access the Trigger Menu, Change the Trigger Mode, and Open the Trigger Level Dialog Box / 32

## 2 Horizontal Controls

To adjust the horizontal (time/div) scale / 37

To adjust the horizontal delay (position) / 38

Panning and Zooming Single or Stopped Acquisitions / 39

To change the horizontal time mode (Normal, XY, or Roll) / 40

    XY Time Mode / 40

To display the zoomed time base / 43

- To change the horizontal scale coarse/fine adjustment setting / 45
- To position the time reference (left, center, right, custom) / 46
- Searching for Events / 47
  - To set up searches / 47
  - To copy search setups / 47
- Navigating the Time Base / 49
  - To navigate time / 49
  - To navigate search events / 49
  - To navigate segments / 50

### 3 Vertical Controls

- To turn waveforms on or off (channel or math) / 53
- To adjust the vertical scale / 54
- To adjust the vertical position / 55
- To specify channel coupling / 56
- To specify channel input impedance / 57
- To specify band width limiting / 58
- To change the vertical scale coarse/fine adjustment setting / 59
- To invert a waveform / 60
- Setting Analog Channel Probe Options / 61
  - To specify the channel units / 61
  - To specify the probe attenuation / 61
  - To specify the probe skew / 62
  - To calibrate a probe / 62

### 4 Math Waveforms

- To display math waveforms / 66
- To adjust the math waveform scale and offset / 68
- Units for Math Waveforms / 69
- Math Operators / 70
  - Add or Subtract / 70
  - Multiply or Divide / 71



Math Transforms /	72
Differentiate /	72
Integrate /	73
FFT Magnitude, FFT Phase /	75
Square Root /	83
Ax + B /	83
Square /	84
Absolute Value /	84
Common Logarithm /	85
Natural Logarithm /	85
Exponential /	86
Base 10 Exponential /	86
Math Filters /	88
High Pass and Low Pass Filter /	88
Averaged Value /	89
Smoothing /	90
Envelope /	90
Math Visualizations /	91
Magnify /	91
Maximum/Minimum /	92
Peak-Peak /	92
Max/Min Hold /	92
Measurement Trend /	92
The Measurement Record and Waveform Math /	94

## 5 Reference Waveforms

To save a waveform to a reference waveform location /	98
To display a reference waveform /	99
To display reference waveform information /	100
To scale and position reference waveforms /	101
To adjust reference waveform skew /	102
To save/recall reference waveform files /	103

## 6 Serial Decode

Serial Decode Options /	106
Lister /	107
Searching Lister Data /	109

## 7 Display Settings

- To adjust waveform intensity / 112
- To set or clear persistence / 114
- To clear the display / 116
- To select the grid type / 117
- To adjust the grid intensity / 118
- To add an annotation / 119
- To disable/enable antialiasing / 121
- To freeze the display / 122

## 8 Labels

- To turn the label display on or off / 124
- To assign a predefined label to a channel / 125
- To define a new label / 126
- To load a list of labels from a text file you create / 127
- To reset the label library to the factory default / 128

## 9 Triggers

- Adjusting the Trigger Level / 131
- Forcing a Trigger / 132
- Edge Trigger / 133
- Edge then Edge Trigger / 135
- Pulse Width Trigger / 137
- Pattern Trigger / 139
- OR Trigger / 142
- Rise/Fall Time Trigger / 144
- Near Field Communication (NFC) Trigger / 146
- Nth Edge Burst Trigger / 149
- Runt Trigger / 150
- Setup and Hold Trigger / 152

- Video Trigger / 154
  - To set up Generic video triggers / 158
  - To trigger on a specific line of video / 158
  - To trigger on all sync pulses / 159
  - To trigger on a specific field of the video signal / 160
  - To trigger on all fields of the video signal / 161
  - To trigger on odd or even fields / 162
- Serial Trigger / 166
- Zone Qualified Trigger / 167

## 10 Trigger Mode/Coupling

- To select the Auto or Normal trigger mode / 170
- To select the trigger coupling / 172
- To enable or disable trigger noise rejection / 173
- To enable or disable trigger HF Reject / 174
- To set the trigger holdoff / 175
- External Trigger Input / 176



Maximum voltage at oscilloscope external trigger input / 176

## 11 Acquisition Control

- Running, Stopping, and Making Single Acquisitions (Run Control) / 178
- Overview of Sampling / 180
  - Sampling Theory / 180
  - Aliasing / 180
  - Oscilloscope Band width and Sample Rate / 180
  - Oscilloscope Rise Time / 182
  - Oscilloscope Band width Required / 182
  - Memory Depth and Sample Rate / 183
- Selecting the Acquisition Mode / 184
  - Normal Acquisition Mode / 184
  - Peak Detect Acquisition Mode / 185
  - Averaging Acquisition Mode / 187
  - High Resolution Acquisition Mode / 189
- Realtime Sampling Option / 190
  - Realtime Sampling and Oscilloscope Band width / 190

- Acquiring to Segmented Memory / 191
  - Navigating Segments / 192
  - Measurements, Statistics, and Infinite Persistence with Segmented Memory / 192
  - Segmented Memory Re-Arm Time / 192
  - Saving Data from Segmented Memory / 193

## 12 Cursors

- To make cursor measurements / 197
- Cursor Examples / 199

## 13 Measurements

- To make automatic measurements / 205
- To edit measurements / 207
- Measurements Summary / 208
  - Snapshot All / 209
- Voltage Measurements / 211
  - Peak-Peak / 211
  - Maximum / 211
  - Minimum / 212
  - Amplitude / 212
  - Top / 212
  - Base / 213
  - Overshoot / 213
  - Preshoot / 214
  - Average / 215
  - DC RMS / 215
  - AC RMS / 215
  - Ratio / 217

Time Measurements /	218
Period /	218
Frequency /	219
Counter /	219
+ Width /	220
- Width /	220
Burst Width /	220
Duty Cycle /	220
Bit Rate /	221
Rise Time /	221
Fall Time /	221
Delay /	221
Phase /	222
X at Min Y /	223
X at Max Y /	224
Count Measurements /	225
Positive Pulse Count /	225
Negative Pulse Count /	225
Rising Edge Count /	225
Falling Edges Count /	226
Mixed Measurements /	227
Area /	227
FFT Analysis Measurements /	228
Channel Power /	228
Occupied Bandwidth /	228
Adjacent Channel Power Ratio (ACPR) /	228
Total Harmonic Distortion (THD) /	229
Measurement Thresholds /	230
Measurement Window /	232
Measurement Statistics /	233

## 14 Mask Testing

To create a mask from a "golden" waveform (Automask) /	236
Mask Test Setup Options /	238
Mask Statistics /	240
To manually modify a mask file /	242
Building a Mask File /	245
How is mask testing done? /	248

## 15 Digital Voltmeter and Counter

Digital Voltmeter / 250

Counter / 252

## 16 Frequency Response Analysis

To make connections / 256

To set up and run the analysis / 257

To view and save the analysis results / 259

## 17 Waveform Generator

To select generated waveform types and settings / 262

To edit arbitrary waveforms / 265

    Creating New Arbitrary Waveforms / 266

    Editing Existing Arbitrary Waveforms / 267

    Capturing Other Waveforms to the Arbitrary Waveform / 270

Output Settings / 271

    To specify the expected output load / 271

    To invert the waveform generator output / 271

    To output a single-shot waveform / 272

    To output the waveform generator sync pulse / 272

To use waveform generator logic presets / 273

To add noise to the waveform generator output / 274

To add modulation to the waveform generator output / 275

    To set up Amplitude Modulation (AM) / 275

    To set up Frequency Modulation (FM) / 276

    To set up Frequency-Shift Keying Modulation (FSK) / 278

To restore waveform generator defaults / 279

## 18 Save/Email/Recall (Setups, Screens, Data)

- Saving Setups, Screen Images, or Data / 282
  - To save setup files / 283
  - To save BMP or PNG image files / 283
  - To save CSV, ASCII XY, or BIN data files / 284
  - Length Control / 285
  - To save Lister data files / 286
  - To save reference waveform files / 286
  - To save masks / 287
  - To save arbitrary waveforms / 287
  - To navigate storage locations / 287
  - To enter file names / 288
- Emailing Setups, Screen Images, or Data / 289
- Recalling Setups, Masks, or Data / 290
  - To recall setup files / 290
  - To recall mask files / 290
  - To recall reference waveform files / 291
  - To recall arbitrary waveforms / 291
- Recalling Default Setups / 292

## 19 Utility Settings

- File Explorer / 294
- Setting Oscilloscope Preferences / 295
  - To choose "expand about" center or ground / 295
  - To set Autoscale preferences / 295
- Setting the Reference Signal Mode / 297
  - To use an external sample clock / 297
  - 
    - Maximum input voltage at Ref I/O connector / 297
    - To output the oscilloscope's system clock / 298
- Setting the Aux Out Source / 299
- Enabling Remote Command Logging / 300

Performing Service Tasks /	301
To perform user calibration /	301
To perform hardware self test /	302
To display oscilloscope information /	302
To display the user calibration status /	302
To check warranty and extended services status /	303
To contact Keysight /	303
To return the instrument /	303
Configuring the Quick Action Menu Item /	304

## 20 Reference

Installing Licenses and Displaying License Information /	306
Licensed Options Available /	307
Other Options Available /	308
Software and Firmware Updates /	309
Binary Data (.bin) Format /	310
Binary Data in MATLAB /	310
Binary Header Format /	311
Example Program for Reading Binary Data /	313
Examples of Binary Files /	313
CSV and ASCII XY files /	317
CSV and ASCII XY file structure /	317
Minimum and Maximum Values in CSV Files /	317
Frequency Data in CSV Files /	318
Acknowledgements /	319

## 21 CAN/LIN Triggering and Serial Decode

Setup for CAN/CAN FD Signals /	322
Loading and Displaying CAN Symbolic Data /	325
CAN/CAN FD Triggering /	326
CAN/CAN FD Serial Decode /	329
Interpreting CAN/CAN FD Decode /	330
CAN Totalizer /	331
Interpreting CAN Lister Data /	332
Searching for CAN Data in the Lister /	333
Setup for LIN Signals /	334
Loading and Displaying LIN Symbolic Data /	336



- LIN Triggering / 337
- LIN Serial Decode / 339
  - Interpreting LIN Decode / 340
  - Interpreting LIN Lister Data / 341
  - Searching for LIN Data in the Lister / 341

## 22 CXPI Triggering and Serial Decode

- Setup for CXPI Signals / 344
- CXPI Triggering / 345
- CXPI Serial Decode / 348
  - Interpreting CXPI Decode / 349
  - Interpreting CXPI Lister Data / 350

## 23 I2C Triggering and Serial Decode

- Setup for I2C Signals / 354
- I2C Triggering / 355
- I2C Serial Decode / 358
  - Interpreting I2C Decode / 359
  - Interpreting I2C Lister Data / 360
  - Searching for I2C Data in the Lister / 360

## 24 Manchester/NRZ Triggering and Serial Decode

- Setup for Manchester Signals / 364
- Manchester Triggering / 367
- Manchester Serial Decode / 369
  - Interpreting Manchester Decode / 369
  - Interpreting Manchester Lister Data / 371
- Setup for NRZ Signals / 372
- NRZ Triggering / 375
- NRZ Serial Decode / 377
  - Interpreting NRZ Decode / 378
  - Interpreting NRZ Lister Data / 379

## 25 MIL-STD-1553/ARINC 429 Triggering and Serial Decode

- Setup for MIL-STD-1553 Signals / 382
- MIL-STD-1553 Triggering / 383

- MIL-STD-1553 Serial Decode / 384
  - Interpreting MIL-STD-1553 Decode / 384
  - Interpreting MIL-STD-1553 Lister Data / 386
  - Searching for MIL-STD-1553 Data in the Lister / 387
- Setup for ARINC 429 Signals / 388
- ARINC 429 Triggering / 390
- ARINC 429 Serial Decode / 392
  - Interpreting ARINC 429 Decode / 393
  - ARINC 429 Totalizer / 394
  - Interpreting ARINC 429 Lister Data / 395
  - Searching for ARINC 429 Data in the Lister / 395

## 26 SENT Triggering and Serial Decode

- Setup for SENT Signals / 398
- SENT Triggering / 402
- SENT Serial Decode / 404
  - Interpreting SENT Decode / 404
  - Interpreting SENT Lister Data / 407
  - Searching for SENT Data in the Lister / 408

## 27 UART/RS232 Triggering and Serial Decode

- Setup for UART/RS232 Signals / 410
- UART/RS232 Triggering / 412
- UART/RS232 Serial Decode / 414
  - Interpreting UART/RS232 Decode / 415
  - UART/RS232 Totalizer / 416
  - Interpreting UART/RS232 Lister Data / 416
  - Searching for UART/RS232 Data in the Lister / 417

## 28 USB PD Triggering and Serial Decode

- Setup for USB PD Signals / 420
- USB PD Triggering / 421
- USB PD Serial Decode / 423
  - Interpreting USB PD Decode / 424
  - Interpreting USB PD Lister Data / 425

## Index

# 1 Getting Started

See the Startup Guide / 20

Using the Soft Front Panel (SFP) Interface / 21

Differences Between USB and Benchtop Oscilloscopes / 23

Learn the Mouse Controls / 24

Read this chapter when using the Soft Front Panel (SFP) user interface for the first time.

## See the Startup Guide

See the *Startup Guide* for the following "getting started" topics:

- Installing software on, and connecting the oscilloscope to, the host PC.

### NOTE

A USB 3.0 (SuperSpeed) port on the host PC is required for connection to the P9241/42/43A oscilloscope. USB 2.0 ports will not work.

---

- Opening the P924xA oscilloscope Soft Front Panel (SFP)
- Connecting probes to the oscilloscope
- Inputting a signal
- Recalling the default oscilloscope setup
- Using Autoscale
- Compensating passive probes
- Learning the oscilloscope display

The *Startup Guide* also has this reference information:

- Environmental conditions
- Probes and accessories information
- Product specification and characteristics

For the latest version of the *Startup Guide* manual, see:

[www.keysight.com/manuals/P9241A](http://www.keysight.com/manuals/P9241A)

## Using the Soft Front Panel (SFP) Interface

The Keysight InfiniiVision P924xA SFP has the same user interface as other benchtop Keysight InfiniiVision oscilloscopes. While benchtop oscilloscopes have keys, softkeys, and knobs—obviously different than the modular oscilloscopes—the display interface was also designed to be used with touch screens and connected USB mice, and it is just as easy to use with a mouse on the Windows operating system.

The main differences between using the interface on a benchtop oscilloscope and a modular oscilloscope are:

- Instead of pressing front panel keys to open softkey menus, you use the top-left blue **(Menu)** button.
- Instead of pressing softkeys, you click the softkey label buttons.
- Instead of turning knobs to adjust scales, offsets, delay positions, trigger levels, and cursor positions, there are clickable up/down, increase/decrease icon buttons that appear after clicking these values. Also, you can drag waveforms, trigger levels, and cursors. If there is a scroll wheel on the mouse, you can use it to make adjustments like a knob.

### Access the Built-In Quick Help

Soft Front Panel (SFP) help for the USB oscilloscope is different than in a traditional Windows application. Instead of a Windows HTML Help file you access through a Help menu, the USB oscilloscope's SFP help is the same quick help information that is built-in to benchtop InfiniiVision oscilloscopes.

To access the built-in quick help, press and hold the left-mouse button over a softkey label button.



Quick Help remains on the screen until you close the help dialog box or open another one.

## Select the User Interface Language

Another benefit of having the same user interface as benchtop InfiniiVision oscilloscopes is that you have a localized user interface and built-in quick help.

To select the user interface language:

- 1 Choose **(Menu) > Help Menu**.
- 2 In the Help Menu, click the **Language** softkey label button.
- 3 In the Language popup menu, select the desired language.

The following languages are available: Czech, English, French, German, Italian, Japanese, Korean, Polish, Portuguese, Russian, Simplified Chinese, Spanish, Thai, Traditional Chinese, and Turkish.

## Differences Between USB and Benchtop Oscilloscopes

The Keysight P9241/42/43A oscilloscope feature set is most similar to the InfiniiVision 3000T X-Series benchtop oscilloscope. For comparison, the differences in the P9241/42/43A USB oscilloscopes are:

- Two analog channels in a module (3000T X-Series oscilloscopes can have two or four analog channels).
- No digital channels (or pods, buses, or Bus Timing or Bus State math functions).
- No demo signals.
- Adds Ref I/O MMCX connector (like the 4000 X-Series oscilloscope's 10 MHz REF BNC connector).
- Transparent backgrounds for dialog boxes are not available.
- When saving screen images, invert and grayscale options are not available.
- No dedicated FFT function, but you can choose FFT math function operations.
- Adds FFT Phase math function (to previous FFT Magnitude math function).
- There are new analysis and measurement capabilities for the FFT Magnitude math function.
- No Line source for edge trigger.
- No USB triggering.
- No external input on pattern trigger (just the two analog channels).
- Single-lane decoding supported for IIC and UART/RS-232.
- No support for I2S, SPI, or FlexRay serial decode and triggering.
- No external source is allowed for serial bus sources (as compared to DSO models of the 3000T X-Series).
- The optional Frequency Response Analysis feature is available.
- No printer setup from within the SFP interface.
- In benchtop oscilloscopes, you can access internal storage memory or external memory on USB storage devices. In the USB oscilloscopes, all storage memory is on the chassis controller PC, and there is no distinction between internal and external storage locations.
- There is no Secure Erase feature in the USB oscilloscopes because non-volatile memory is on the chassis controller PC.
- System dates and times are set by the USB chassis controller PC.
- Calibration protect is a softkey control instead of a physical button.
- Licenses are installed and managed using the Keysight License Manager. On benchtop oscilloscopes, licenses are loaded from .lic files on a USB storage device using the File Explorer.

## Learn the Mouse Controls

In the Soft Front Panel (SFP) user interface, you can control the oscilloscope with a mouse by clicking and dragging different areas of the user interface. You can:

- **"Access Controls and Menu Using the Main Menu Icon"** on page 24
- **"Draw Rectangles for Waveform Zoom or Zone Trigger Set Up"** on page 26
- **"Drag to Scale, Position, and Change Offset"** on page 26
- **"Select Sidebar Information or Controls"** on page 27
- **"Undock Sidebar Dialog Boxes by Dragging"** on page 28
- **"Re-dock Sidebar Dialog Boxes to a Split Sidebar"** on page 29
- **"Select Dialog Box Menus and Close Dialog Boxes"** on page 29
- **"Drag Cursors"** on page 29
- **"Click Softkeys and Menu On the Screen"** on page 30
- **"Enter Names Using Alpha-Numeric Keypad Dialog Boxes"** on page 30
- **"Change Waveform Offsets By Dragging Ground Reference Icons"** on page 31
- **"Turn Channels On/Off and Open Scale/Offset Dialog Boxes"** on page 31
- **"Access the Horizontal Menu and Open the Scale/Delay Dialog Box"** on page 32
- **"Access the Trigger Menu, Change the Trigger Mode, and Open the Trigger Level Dialog Box"** on page 32

### Access Controls and Menu Using the Main Menu Icon

- 1 Click the upper-left menu icon to open the main menu.

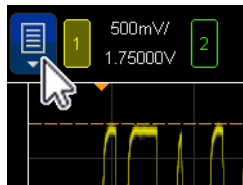

- 2 Click left side controls to perform oscilloscope operations.



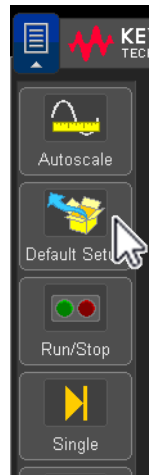

3 Click menu items and submenu items to access menus and additional controls.

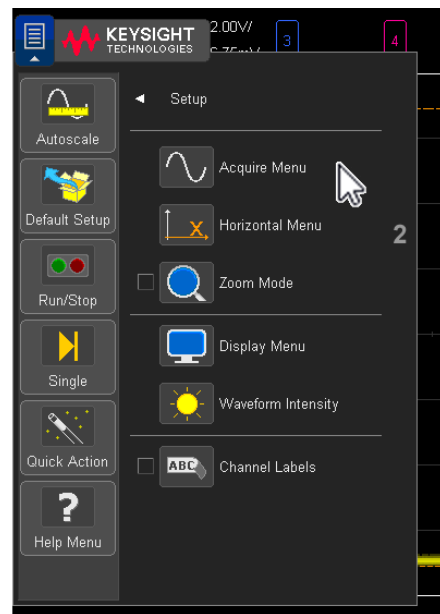
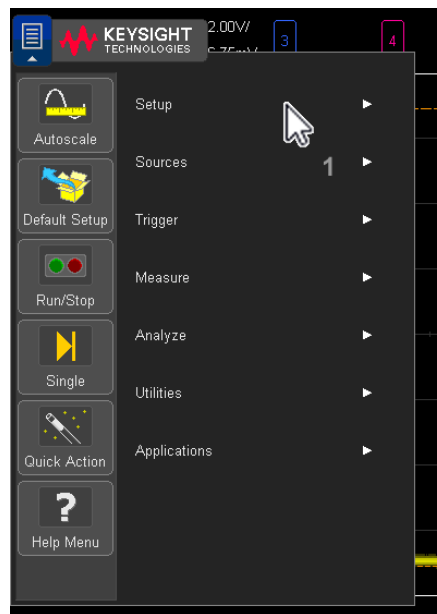

## Draw Rectangles for Waveform Zoom or Zone Trigger Set Up

- 1 Click the upper-right corner to select the rectangle draw mode.



- 2 Drag the mouse pointer across the screen to draw a rectangle.
- 3 Release the mouse key.
- 4 Click the desired option from the popup menu.

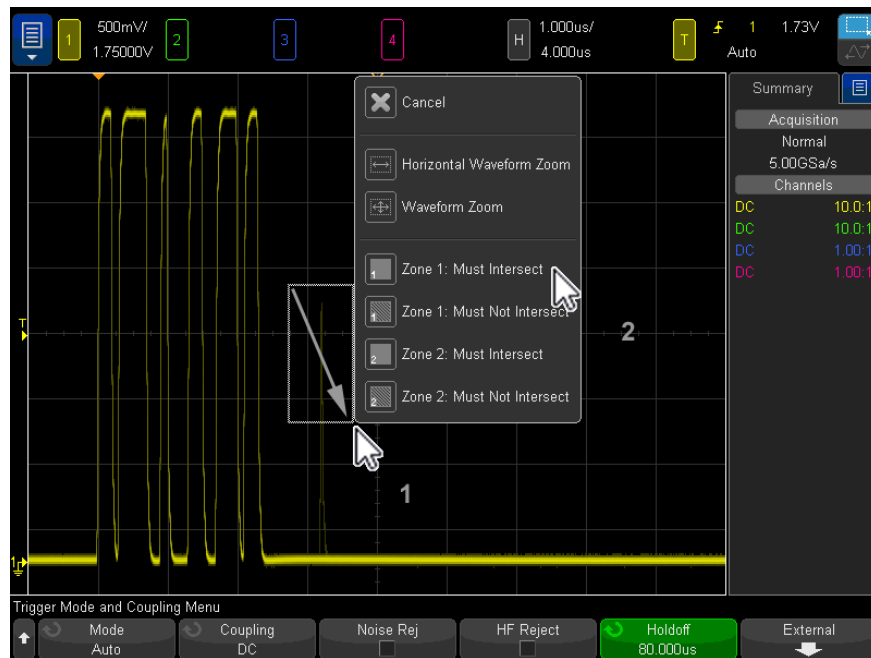

## Drag to Scale, Position, and Change Offset

- 1 Click the upper-right corner to select the horizontal drag mode.



- When the waveform drag mode is selected, you can:

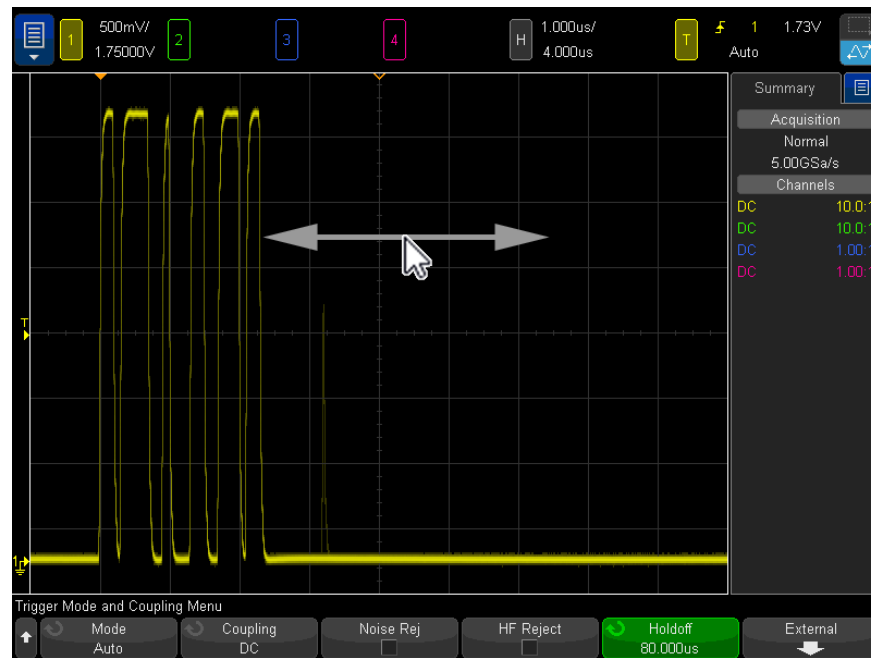

- Drag – drag the mouse pointer across the screen to change the horizontal delay. Drag a waveform up or down to change the vertical offset.

To select waveforms, click them. The waveform closest horizontally to the click location is selected. The selected waveform is indicated by the ground marker with the filled background (channel 1 in the following example).

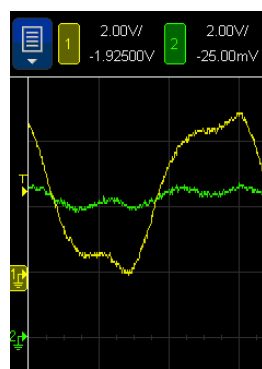

## Select Sidebar Information or Controls

- Click the blue menu icon in the sidebar.
- In the popup menu, click the type of information or controls you want to see in the sidebar.

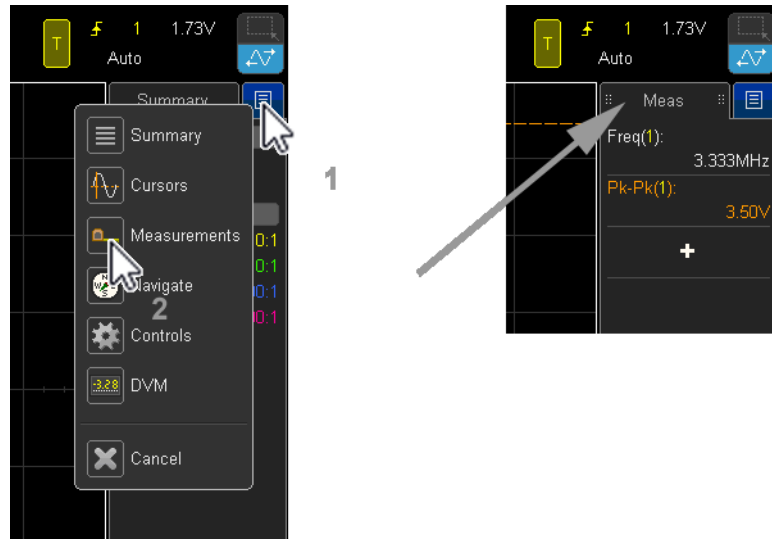

## Undock Sidebar Dialog Boxes by Dragging

Sidebar dialog boxes can be undocked and placed anywhere on the screen.

- 1 Drag the sidebar dialog box title wherever you like.

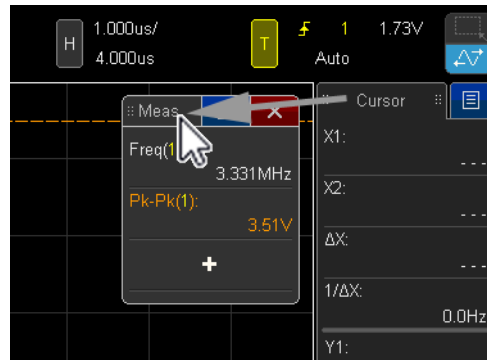

This lets you view multiple types of information or controls at the same time.

## Re-dock Sidebar Dialog Boxes to a Split Sidebar

Sidebar dialog boxes can be re-docked to either half or full height of the sidebar.

- 1 Drag the dialog box title back to the desired sidebar target.

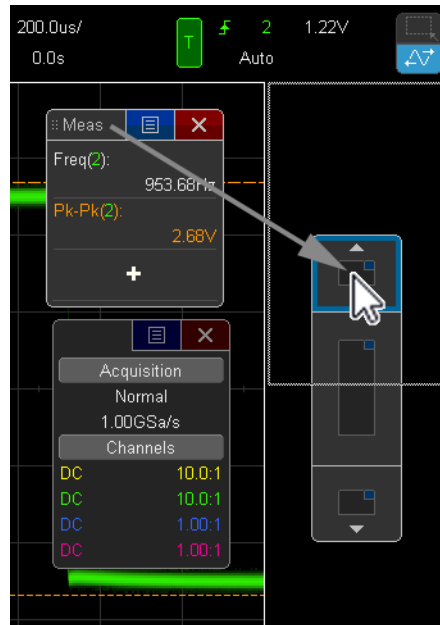

You can display two dialog boxes in the sidebar at the same time.

## Select Dialog Box Menus and Close Dialog Boxes

- Click the blue menu icon in the dialog box for options.

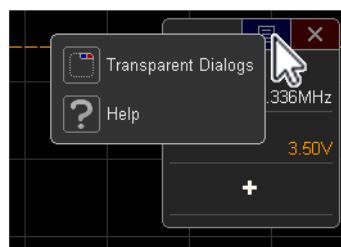

- Click the red "X" icon to close a dialog box.

## Drag Cursors

When "Manual" cursors mode is selected, you can drag the cursor name handles to position them.

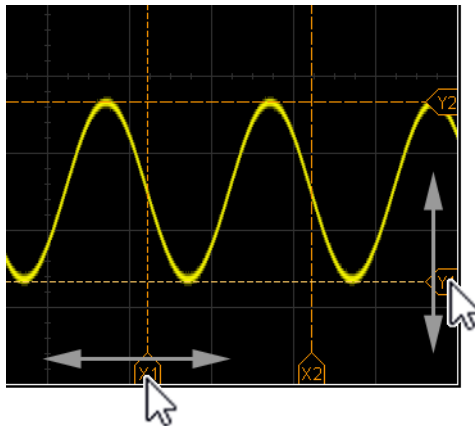

### Click Softkeys and Menus On the Screen

- Click softkey label buttons to select them.
- When softkeys provide menus, click to select a menu item.

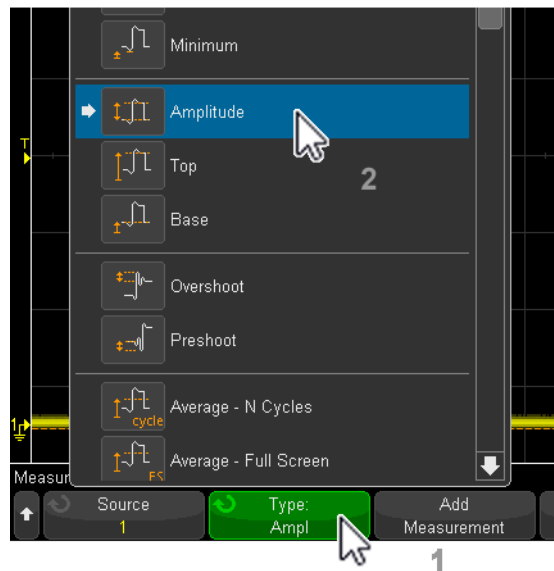

### Enter Names Using Alpha-Numeric Keypad Dialog Boxes

Some softkey label buttons open alpha-numeric dialog boxes that let you enter names using a mouse or keyboard.

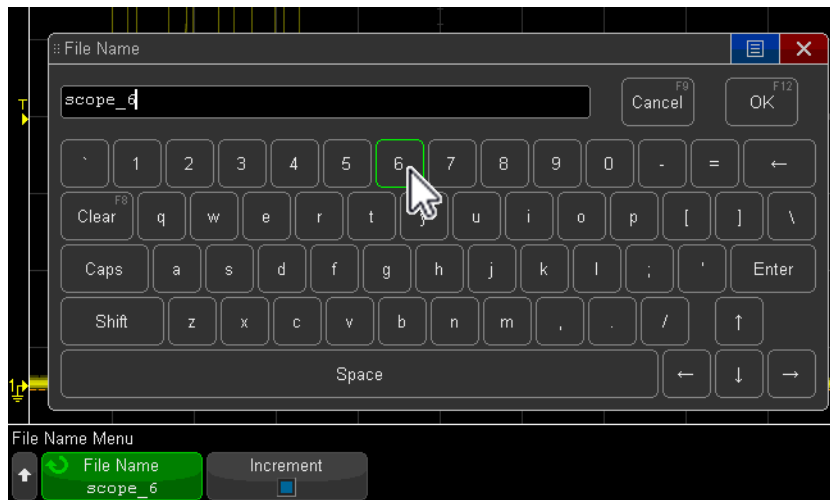

## Change Waveform Offsets By Dragging Ground Reference Icons

You can drag ground icons to change a waveform's vertical offset.



## Turn Channels On/Off and Open Scale/Offset Dialog Boxes

- Click channel numbers to turn them on or off.

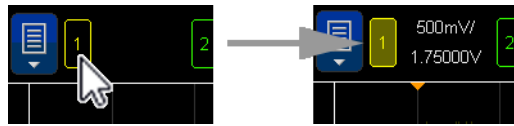

- When channels are on, click the scale and offset values to access a dialog box for changing them.

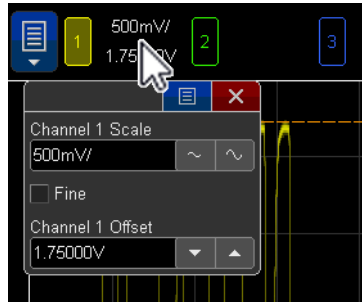

### Access the Horizontal Menu and Open the Scale/Delay Dialog Box

- Click "H" to access the Horizontal Menu.



- Click the horizontal scale and delay values to access a dialog box for changing them.

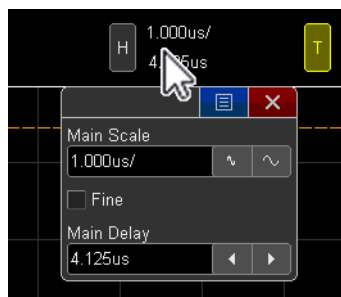

### Access the Trigger Menu, Change the Trigger Mode, and Open the Trigger Level Dialog Box

- Click "T" to access the Trigger Menu.



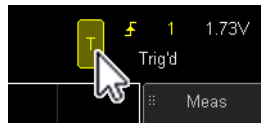

- Click the trigger level value(s) to access a dialog box for changing the level(s).

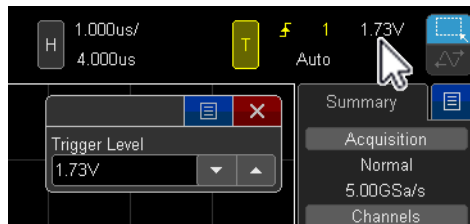

- Click "Auto" or "Trig'd" to quickly toggle the trigger mode.

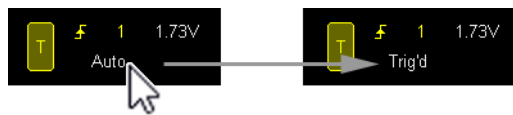



## 2 Horizontal Controls

To adjust the horizontal (time/div) scale / 37

To adjust the horizontal delay (position) / 38

Panning and Zooming Single or Stopped Acquisitions / 39

To change the horizontal time mode (Normal, XY, or Roll) / 40

To display the zoomed time base / 43

To change the horizontal scale coarse/fine adjustment setting / 45

To position the time reference (left, center, right, custom) / 46

Searching for Events / 47

Navigating the Time Base / 49

The horizontal controls include:

- The **H** button or **Main Menu > Setup > Horizontal Menu** menu item for accessing the Horizontal Menu.
- The horizontal scale and delay dialog box.
- The **Main Menu > Setup > Zoom Mode** menu item or **Zoom** softkey button for quickly enabling/disabling the split-screen zoom display.
- The **Main Menu > Analyze > Waveform Search** menu item for finding events on analog channels or in serial decode.
- The sidebar **Navigate** controls for navigating time, search events, or segmented memory acquisitions.

The following figure shows the Horizontal Menu which appears after choosing **Main Menu > Setup > Horizontal Menu**.

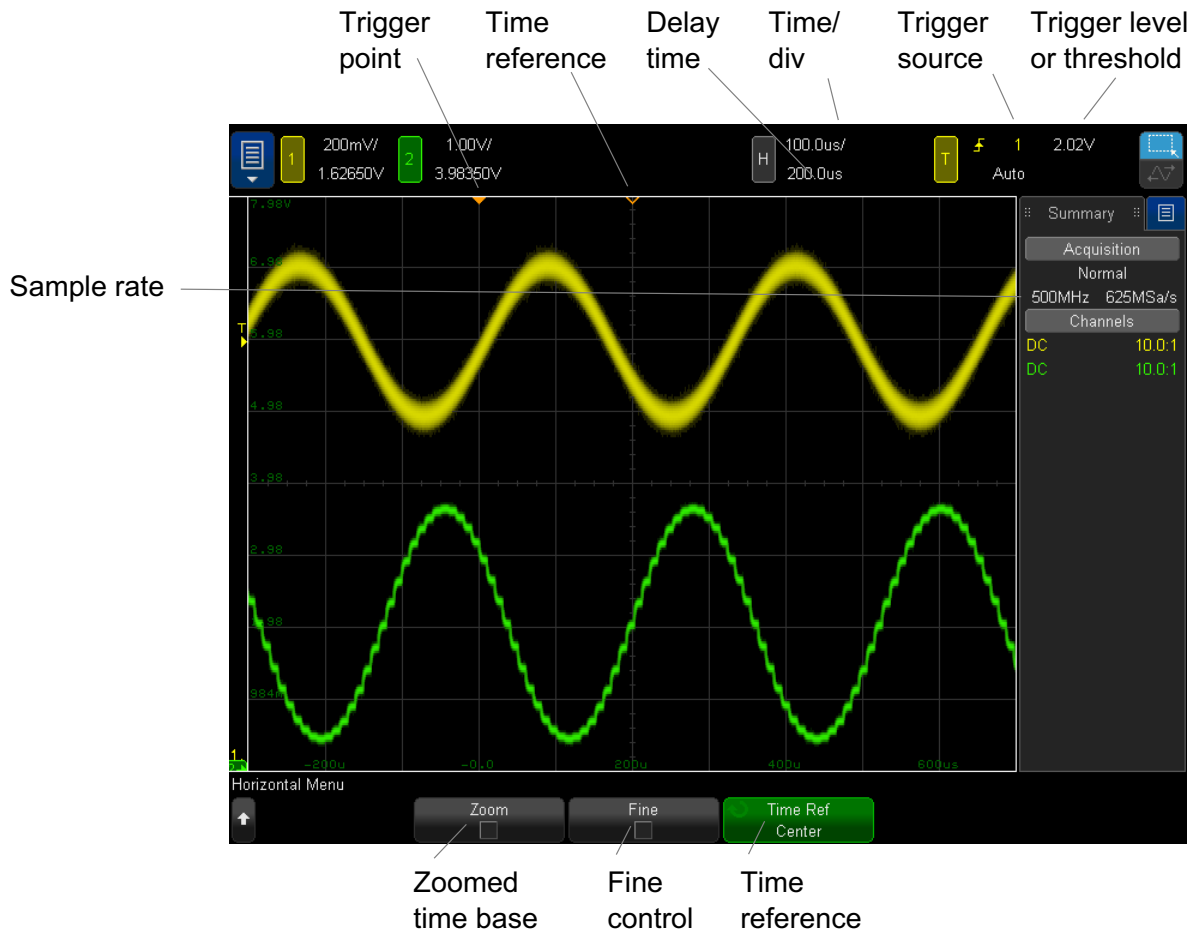

**Figure 1** Horizontal Menu

The Horizontal Menu lets you enable Zoom, set the time base fine control (vernier), and specify the time reference.

The current sample rate is displayed in the Summary box in the right-side information area.

## To adjust the horizontal (time/div) scale

- 1 Click the horizontal scale value to access a dialog box for changing it. See **"Access the Horizontal Menu and Open the Scale/Delay Dialog Box"** on page 32.

Notice how the time/div information in the status line changes.

The ▽ symbol at the top of the display indicates the time reference point.

Changing the horizontal scale works while acquisitions are running or when they are stopped. When running, adjusting the horizontal scale changes the sample rate. When stopped, adjusting the horizontal scale lets you zoom into acquired data. See **"Panning and Zooming Single or Stopped Acquisitions"** on page 39.

Note that there are separate horizontal scale controls in the Zoom display. See **"To display the zoomed time base"** on page 43.

## To adjust the horizontal delay (position)

- 1 Click the horizontal delay value to access a dialog box for changing it. See **"Access the Horizontal Menu and Open the Scale/Delay Dialog Box"** on page 32.

You can also drag a waveform horizontally to change its delay. See **"Drag to Scale, Position, and Change Offset"** on page 26.

The trigger point moves horizontally, pausing at 0.00 s (mimicking a mechanical detent), and the delay value is displayed in the status line.

Changing the delay time moves the trigger point (solid inverted triangle) horizontally and indicates how far it is from the time reference point (hollow inverted triangle ▽). These reference points are indicated along the top of the display grid.

**Figure 1** shows the trigger point with the delay time set to 200  $\mu$ s. The delay time number tells you how far the time reference point is located from the trigger point. When delay time is set to zero, the delay time indicator overlays the time reference indicator.

All events displayed left of the trigger point happened before the trigger occurred. These events are called pre-trigger information, and they show events that led up to the trigger point.

Everything to the right of the trigger point is called post-trigger information. The amount of delay range (pre-trigger and post-trigger information) available depends on the time/div selected and memory depth.

Changing the horizontal position works while acquisitions are running or when they are stopped. When running, adjusting the horizontal delay changes the amount of pre- and post-trigger information. When stopped, adjusting the horizontal position lets you pan acquired data. See **"Panning and Zooming Single or Stopped Acquisitions"** on page 39.

Note that there are separate horizontal scale controls in the Zoom display. See **"To display the zoomed time base"** on page 43.

## Panning and Zooming Single or Stopped Acquisitions

When the oscilloscope is stopped, use the horizontal scale and position controls to pan and zoom your waveform. The stopped display may contain several acquisitions worth of information, but only the last acquisition is available for pan and zoom.

The ability to pan (move horizontally) and scale (expand or compress horizontally) an acquired waveform is important because of the additional insight it can reveal about the captured waveform. This additional insight is often gained from seeing the waveform at different levels of abstraction. You may want to view both the big picture and the specific little picture details.

The ability to examine waveform detail after the waveform has been acquired is a benefit generally associated with digital oscilloscopes. Often this is simply the ability to freeze the display for the purpose of measuring with cursors or printing the screen. Some digital oscilloscopes go one step further by including the ability to further examine the signal details after acquiring them by panning through the waveform and changing the horizontal scale.

There is no limit imposed on the scaling ratio between the time/div used to acquire the data and the time/div used to view the data. There is, however, a useful limit. This useful limit is somewhat a function of the signal you are analyzing.

### NOTE

#### **Zooming into stopped acquisitions**

The screen will still contain a relatively good display if you zoom-in horizontally by a factor of 1000 and zoom-in vertically by a factor of 10 to display the information from where it was acquired. Remember that you can only make automatic measurements on displayed data.

---

## To change the horizontal time mode (Normal, XY, or Roll)

1 Click the **H** button or choose **Main Menu > Setup > Horizontal Menu**.

2 In the Horizontal Menu, click **Time Mode**; then, select:

- **Normal** – the normal viewing mode for the oscilloscope.

In the Normal time mode, signal events occurring before the trigger are plotted to the left of the trigger point (▼) and signal events after the trigger plotted to the right of the trigger point.

- **XY** – XY mode changes the display from a volts-versus-time display to a volts-versus-volts display. The time base is turned off. Channel 1 amplitude is plotted on the X-axis and Channel 2 amplitude is plotted on the Y-axis.

You can use XY mode to compare frequency and phase relationships between two signals. XY mode can also be used with transducers to display strain versus displacement, flow versus pressure, volts versus current, or voltage versus frequency.

Use the cursors to make measurements on XY mode waveforms.

For more information about using XY mode for measurements, refer to "**XY Time Mode**" on page 40.

- **Roll** – causes the waveform to move slowly across the screen from right to left. It only operates on time base settings of 50 ms/div and slower. If the current time base setting is faster than the 50 ms/div limit, it will be set to 50 ms/div when Roll mode is entered.

In Roll mode there is no trigger. The fixed reference point on the screen is the right edge of the screen and refers to the current moment in time. Events that have occurred are scrolled to the left of the reference point. Since there is no trigger, no pre-trigger information is available.

If you would like to pause the display in Roll mode, choose **Main Menu > Single**. To clear the display and restart an acquisition in Roll mode, choose **Main Menu > Single** again.

Use Roll mode on low-frequency waveforms to yield a display much like a strip chart recorder. It allows the waveform to roll across the display.

### XY Time Mode

The XY time mode converts the oscilloscope from a volts-versus-time display to a volts-versus-volts display using two input channels. Channel 1 is the X-axis input, channel 2 is the Y-axis input. You can use various transducers so the display could show strain versus displacement, flow versus pressure, volts versus current, or voltage versus frequency.



**Example** This exercise shows a common use of the XY display mode by measuring the phase difference between two signals of the same frequency with the Lissajous method.

- 1 Connect a sine wave signal to channel 1, and a sine wave signal of the same frequency but out of phase to channel 2.
- 2 Choose **Main Menu > Autoscale**.
- 3 Click the **H** button or choose **Main Menu > Setup > Horizontal Menu**.
- 4 In the Horizontal Menu, click **Time Mode** and select "XY".
- 5 Center the signal on the display with the channel 1 and 2 offset controls. Use the channel 1 and 2 volts/div controls and the channel 1 and 2 **Fine** option to expand the signal for convenient viewing.

The phase difference angle ( $\theta$ ) can be calculated using the following formula (assuming the amplitude is the same on both channels):

$$\sin\theta = \frac{A}{B} \text{ or } \frac{C}{D}$$

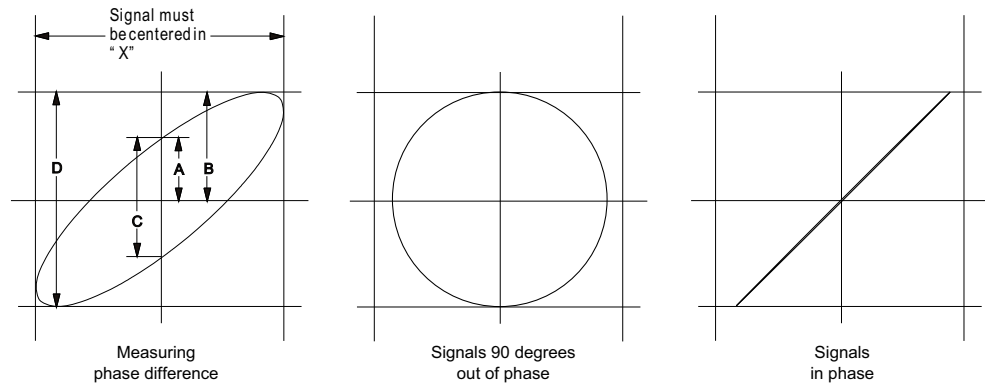
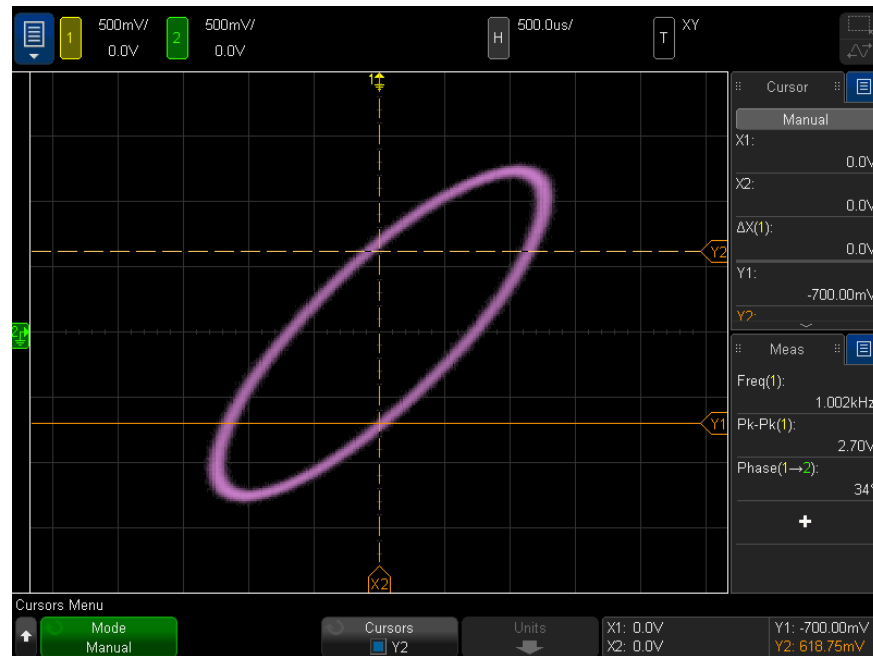

**Figure 2** XY time mode signals, centered on display

- 6 Choose **Main Menu > Measure > Cursors**.
- 7 Set the Y2 cursor to the top of the signal, and set Y1 to the bottom of the signal.

Note the  $\Delta Y$  value at the bottom of the display. In this example, we are using the Y cursors, but you could have used the X cursors instead.

- 8 Move the Y1 and Y2 cursors to the intersection of the signal and the Y axis. Again, note the  $\Delta Y$  value.



**Figure 3** Phase difference measurements, automatic and using cursors

- 9 Calculate the phase difference using the formula below.

For example, if the first  $\Delta Y$  value is 2.297 and the second  $\Delta Y$  value is 1.319:

$$\sin\theta = \frac{\text{second } \Delta Y}{\text{first } \Delta Y} = \frac{1.319}{2.297}; \theta = 35.05 \text{ degrees of phase shift}$$

#### NOTE

#### Z-Axis Input in XY Display Mode (Blanking)

When you select the XY display mode, the time base is turned off. Channel 1 is the X-axis input, channel 2 is the Y-axis input, and the EXT TRIG IN is the Z-axis input. If you only want to see portions of the Y versus X display, use the Z-axis input. Z-axis turns the trace on and off (analog oscilloscopes called this Z-axis blanking because it turned the beam on and off). When Z is low (<1.4 V), Y versus X is displayed; when Z is high (>1.4 V), the trace is turned off.

## To display the zoomed time base

Zoom, formerly called Delayed sweep mode, is a horizontally expanded version of the normal display. When Zoom is selected, the display divides in half. The top half of the display shows the normal time/div window and the bottom half displays a faster Zoom time/div window.

The Zoom window is a magnified portion of the normal time/div window. You can use Zoom to locate and horizontally expand part of the normal window for a more detailed (higher-resolution) analysis of signals.

To turn on (or off) Zoom:

- 1 Choose **Main Menu > Setup > Zoom Mode** (or in the Horizontal Menu, click the **Zoom** softkey button).

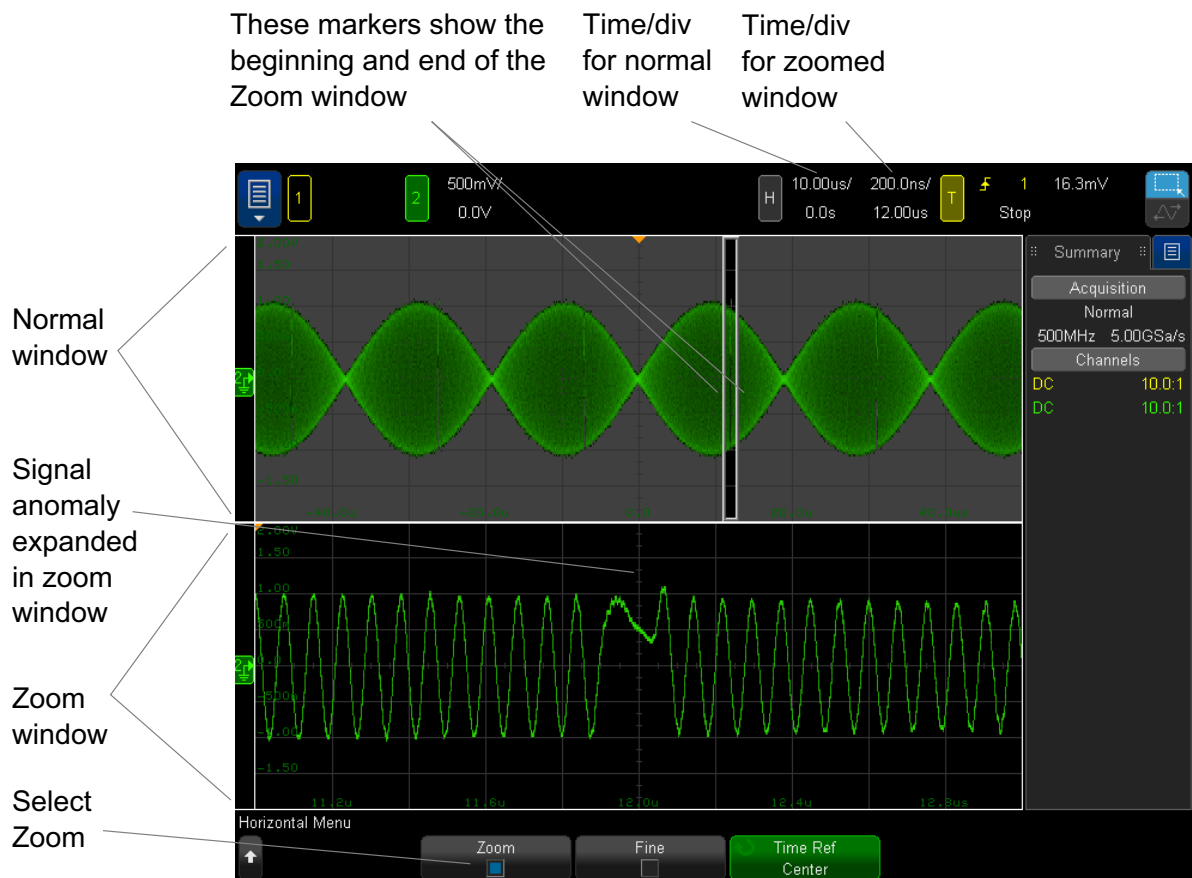

The area of the normal display that is expanded is outlined with a box and the rest of the normal display is ghosted. The box shows the portion of the normal sweep that is expanded in the lower half.

To change the time/div for the Zoom window, click the horizontal zoom scale value to access a dialog box for changing it. As you change the zoom scale, the zoomed window time/div is highlighted in the status line above the waveform display area. The Horizontal zoom scale control controls the size of the box.

The Horizontal zoom delay control sets the left-to-right position of the zoom window. The delay value, which is the time displayed relative to the trigger point) is momentarily displayed in the upper-right portion of the display when the zoom delay control is adjusted.

Negative delay values indicate you're looking at a portion of the waveform before the trigger event, and positive values indicate you're looking at the waveform after the trigger event.

For information about using zoom mode for measurements, refer to **"To isolate a pulse for Top measurement"** on page 212 and **"To isolate an event for frequency measurement"** on page 219.

## To change the horizontal scale coarse/fine adjustment setting

- 1 Select or clear the **Fine** control in the horizontal scale dialog box (or the **Fine** softkey in the Horizontal Menu) to toggle between fine and coarse adjustment of the horizontal scale.

When **Fine** is enabled, adjusting the horizontal scale changes the time/div (displayed in the status line at the top of the display) in smaller increments. The time/div remains fully calibrated when **Fine** is on.

When **Fine** is turned off, adjusting the horizontal scale changes the time/div setting in a 1-2-5 step sequence.

## To position the time reference (left, center, right, custom)

Time reference is the reference point on the display for delay time (horizontal position).

- 1 Click the **H** button or choose **Main Menu > Setup > Horizontal Menu**.
- 2 In the Horizontal Menu, click **Time Ref**; then, select:
  - **Left** – the time reference is set to one major division from the left edge of the display.
  - **Center** – the time reference is set to the center of the display.
  - **Right** – the time reference is set to one major division from the right edge of the display.
  - **Custom Location** – lets you place the time reference location at a percent of the graticule width (where 0% is the left edge and 100% is the right edge).

A small hollow triangle (∇) at the top of the display grid marks the position of the time reference. When delay time is set to zero, the trigger point indicator (▼) overlays the time reference indicator.

The time reference position sets the initial position of the trigger event within acquisition memory and on the display, with delay set to 0.

Adjusting the horizontal scale (sweep speed) expands or contracts the waveform about the time reference point (∇). See **"To adjust the horizontal (time/div) scale"** on page 37.

Adjusting the horizontal position in Normal mode (not Zoom) moves the trigger point indicator (▼) to the left or right of the time reference point (∇). See **"To adjust the horizontal delay (position)"** on page 38.

## Searching for Events

You can use the Search Menu to search for Edge, Pulse Width, Rise/Fall Time, Runt, Frequency Peaks, and Serial events on the analog channels.

Setting up searches (see **"To set up searches"** on page 47) is similar to setting up triggers. In fact, except for Frequency Peaks and Serial events, you can copy search setups to trigger setups and vice-versa (see **"To copy search setups"** on page 47).

Searches are different than triggers in that they use the measurement threshold settings instead of trigger levels.

Found search events are marked with white triangles at the top of the graticule, and the number of events found is displayed in the menu line just above the softkey labels.

### To set up searches

- 1 Choose **Main Menu > Analyze > Waveform Search**.
- 2 In the Search Menu, click **Search**; then, select the search type.
- 3 Use the remaining softkeys to set up the selected search type.

In most cases, setting up searches is similar to setting up triggers:

- For setting up Edge searches, see **"Edge Trigger"** on page 133.
- For setting up Pulse Width searches, see **"Pulse Width Trigger"** on page 137.
- For setting up Rise/Fall Time searches, see **"Rise/Fall Time Trigger"** on page 144.
- For setting up Runt searches, see **"Runt Trigger"** on page 150.
- For setting up Frequency Peak searches, see **"Searching for FFT Peaks"** on page 79.
- For setting up Serial searches, see **"Serial Trigger"** on page 166 and **"Searching Lister Data"** on page 109.

Remember that searches use the measurement threshold settings instead of trigger levels. Use the **Thresholds** softkey in the Search Menu to access the Measurement Threshold Menu. See **"Measurement Thresholds"** on page 230.

### To copy search setups

Except for Frequency Peak and Serial event search setups, you can copy search setups to trigger setups and vice-versa.

- 1 Choose **Main Menu > Analyze > Waveform Search**.
- 2 In the Search Menu, click **Search**; then, select the search type.

**3** Click **Copy**.

**4** In the Search Copy Menu:

- Click **Copy to Trigger** to copy the setup for the selected search type to the same trigger type. For example, if the current search type is Pulse Width, clicking **Copy to Trigger** copies the search settings to the Pulse Width trigger settings and selects the Pulse Width trigger.
- Click **Copy from Trigger** to copy the trigger setup for the selected search type to the search setup.
- To undo a copy, click **Undo Copy**.

The softkeys in the Search Copy Menu may not be available when one of the settings cannot be copied or there is no trigger type that corresponds to the search type.



## Navigating the Time Base



You can use the sidebar **Navigate** controls to navigate through:

- Captured data (see "**To navigate time**" on page 49).
- Search events (see "**To navigate search events**" on page 49).
- Segments, when segmented memory acquisitions are turned on (see "**To navigate segments**" on page 50).

See "**Select Sidebar Information or Controls**" on page 27.

### To navigate time

When acquisitions are stopped, you can use the navigation controls to play through the captured data.

- 1 Click the blue menu icon in the sidebar.
- 2 In the popup menu, click **Navigate**.
- 3 Click the button at the top of the Navigate sidebar dialog box; then, click **-> Navigate Menu**.
- 4 In the Navigate Menu, click **Navigate**; then, select **Time**.
- 5 Click the  navigation buttons to play backward, stop, or play forward in time. You can click the  or  buttons multiple times to speed up the playback. There are three speed levels.

### To navigate search events

When acquisitions are stopped, you can use the navigation controls to go to found search events (set using Waveform Search, see "**Searching for Events**" on page 47).

- 1 Click the blue menu icon in the sidebar.
- 2 In the popup menu, click **Navigate**.
- 3 Click the button at the top of the Navigate sidebar dialog box; then, click **-> Navigate Menu**.
- 4 In the Navigate Menu, click **Navigate**; then, select **Search**.
- 5 Click the  back and forward buttons to go to the previous or next search event.

When searching Serial decode:



- You can click the  stop button to set or clear a mark.
- The **Auto Zoom** softkey specifies whether the waveform display is automatically zoomed to fit the marked row as you navigate.

## To navigate segments



When the segmented memory acquisition is enabled and acquisitions are stopped, you can use the navigation controls to play through the acquired segments.

- 1 Click the blue menu icon in the sidebar.
- 2 In the popup menu, click **Navigate**.
- 3 Click the button at the top of the Navigate sidebar dialog box; then, click **-> Navigate Menu**.
- 4 In the Navigate Menu, click **Navigate**; then, select **Segments**.
- 5 Click **Play Mode**; then, select:
  - **Manual** – to play through segments manually.

In the Manual play mode:

- Click the  back and forward buttons to go to the previous or next segment.
- Click the  softkey to go to the first segment.
- Click the  softkey to go to the last segment.
- **Auto** – to play through segments in an automated fashion.

In the Auto play mode:

- Click the  navigation buttons to play backward, stop, or play forward in time. You can click the  or  buttons multiple times to speed up the playback. There are three speed levels.

## 3 Vertical Controls

- To turn waveforms on or off (channel or math) / 53
- To adjust the vertical scale / 54
- To adjust the vertical position / 55
- To specify channel coupling / 56
- To specify channel input impedance / 57
- To specify bandwidth limiting / 58
- To change the vertical scale coarse/fine adjustment setting / 59
- To invert a waveform / 60
- Setting Analog Channel Probe Options / 61

The vertical controls include:

- The **1** or **2** buttons for turning a channel on or off and accessing the channel's softkey menu.
- The vertical scale and position dialog boxes for each analog channel.

The following figure shows the Channel 1 Menu that appears after clicking the channel **1** button.

### 3 Vertical Controls

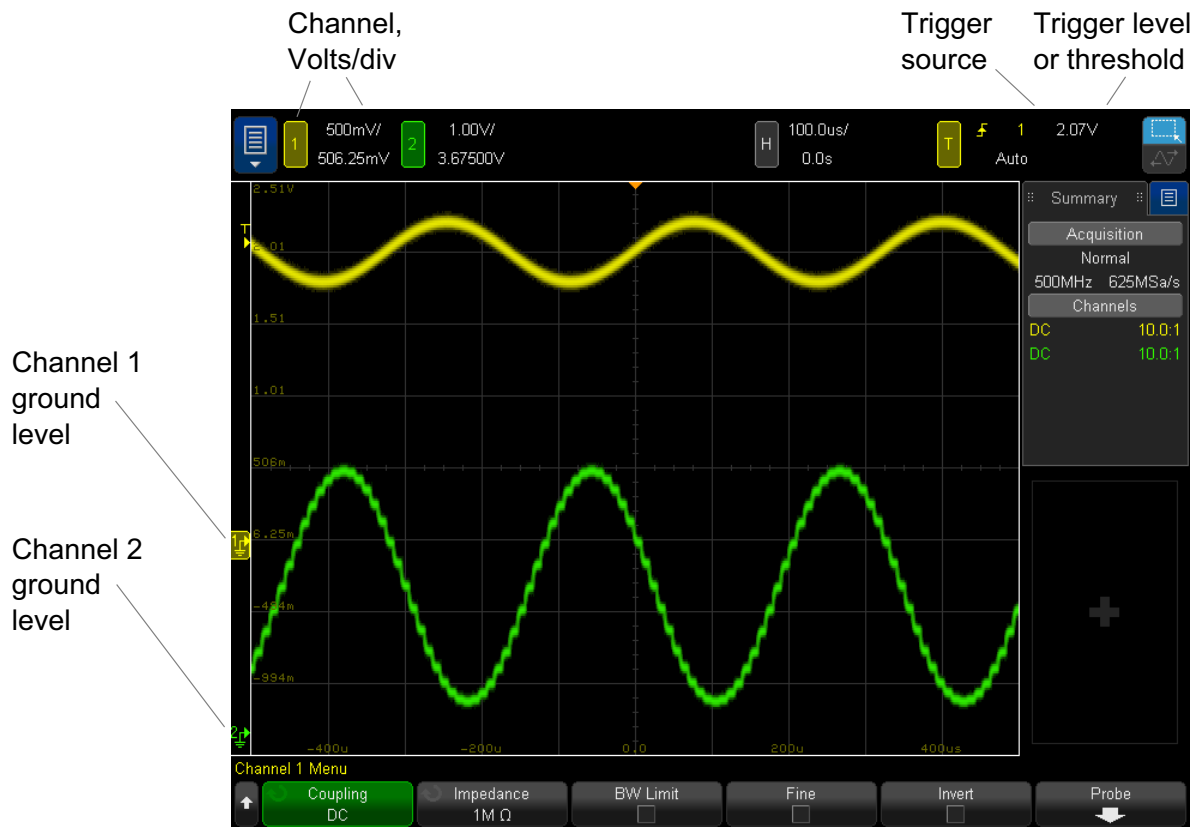

The ground level of the signal for each displayed analog channel is identified by the position of the  icon at the far-left side of the display.

## To turn waveforms on or off (channel or math)

- 1 Click channel numbers to turn them on or off. See "[Turn Channels On/Off and Open Scale/Offset Dialog Boxes](#)" on page 31.

When a channel is on, its button is filled with the appropriate color.

### NOTE

#### Turning channels off

You must be viewing the menu for a channel before you can turn it off. For example, if channel 1 and channel 2 are turned on and the menu for channel 2 is being displayed, to turn channel 1 off, click **1** to display the channel 1 menu; then, click **1** again to turn channel 1 off.

---

## To adjust the vertical scale

- 1 When channels are on, click the scale value to access a dialog box for changing it. See **"Turn Channels On/Off and Open Scale/Offset Dialog Boxes"** on page 31.

The vertical scale controls change the analog channel scale in a 1-2-5 step sequence (with a 1:1 probe attached) unless fine adjustment is enabled (see **"To change the vertical scale coarse/fine adjustment setting"** on page 59).

The analog channel Volts/Div value is displayed in the status line.

The default mode for expanding the signal when you adjust the vertical scale is vertical expansion about the ground level of the channel; however, you can change this to expand about the center of the display. See **"To choose "expand about" center or ground"** on page 295.

## To adjust the vertical position

- 1 When channels are on, click the offset value to access a dialog box for changing it. See **"Turn Channels On/Off and Open Scale/Offset Dialog Boxes"** on page 31.

You can also drag a waveform vertically to change its offset. See **"Change Waveform Offsets By Dragging Ground Reference Icons"** on page 31.

The offset voltage value represents the voltage difference between the vertical center of the display and the ground level (⚡) icon. It also represents the voltage at the vertical center of the display if vertical expansion is set to expand about ground (see **"To choose "expand about" center or ground"** on page 295).

## To specify channel coupling

Coupling changes the channel's input coupling to either **AC** (alternating current) or **DC** (direct current).

**TIP**

If the channel is DC coupled, you can quickly measure the DC component of the signal by simply noting its distance from the ground symbol.

If the channel is AC coupled, the DC component of the signal is removed, allowing you to use greater sensitivity to display the AC component of the signal.

---

- 1 Click the desired channel button.
- 2 In the Channel Menu, click the **Coupling** softkey to select the input channel coupling:
  - **DC** – DC coupling is useful for viewing waveforms as low as 0 Hz that do not have large DC offsets.
  - **AC** – AC coupling is useful for viewing waveforms with large DC offsets.

When AC coupling is chosen, you cannot select the 50 Ohm input impedance mode. This is done to prevent damage to the oscilloscope.

AC coupling places a 10 Hz high-pass filter in series with the input waveform that removes any DC offset voltage from the waveform.

Note that Channel Coupling is independent of Trigger Coupling. To change trigger coupling see "[To select the trigger coupling](#)" on page 172.



## To specify channel input impedance

**NOTE**

When you connect an AutoProbe, self-sensing probe, or a compatible InfiniiMax probe, the oscilloscope automatically configures the analog input channels to the correct impedance.

- 1 Click the desired channel number button.
- 2 In the Channel Menu, click **Impedance**; then, select either:
  - **50 Ohm** – matches 50 ohm cables commonly used in making high frequency measurements, and 50 ohm active probes.

When **50 Ohm** input impedance is selected, it is displayed with the channel information on-screen.

When AC coupling is selected (see "**To specify channel coupling**" on page 56) or excessive voltage is applied to the input, the oscilloscope automatically switches to **1M Ohm** mode to prevent possible damage.

- **1M Ohm** – is for use with many passive probes and for general-purpose measurements. The higher impedance minimizes the loading effect of the oscilloscope on the device under test.

This impedance matching gives you the most accurate measurements because reflections are minimized along the signal path.

- See Also**
- For more information on probing, visit: [www.keysight.com/find/scope\\_probes](http://www.keysight.com/find/scope_probes)
  - Information about selecting a probe can be found in document number *Keysight Oscilloscope Probes and Accessories Selection Guide* (part number 5989-6162EN), available at [www.keysight.com](http://www.keysight.com).

## To specify bandwidth limiting

- 1 Click the desired channel number button.
- 2 In the Channel Menu, click **BW Limit** to enable or disable bandwidth limiting.

When bandwidth limit is on, the maximum bandwidth for the channel is approximately 20 MHz. For waveforms with frequencies below this, turning bandwidth limit on removes unwanted high frequency noise from the waveform. The bandwidth limit also limits the trigger signal path of any channel that has **BW Limit** turned on.

## To change the vertical scale coarse/fine adjustment setting

- 1 Select or clear the **Fine** control in the vertical scale dialog box (or the **Fine** softkey in the Channel Menu) to toggle between fine and coarse adjustment of the vertical scale.

When **Fine** adjustment is selected, you can change the channel's vertical sensitivity in smaller increments. The channel sensitivity remains fully calibrated when **Fine** is on.

The vertical scale value is displayed in the status line at the top of the display.

When **Fine** is turned off, adjusting the volts/division changes the channel sensitivity in a 1-2-5 step sequence.

## To invert a waveform

- 1 Click the desired channel number button.
- 2 In the Channel Menu, click **Invert** to invert the selected channel.

When **Invert** is selected, the voltage values of the displayed waveform are inverted.

Invert affects how a channel is displayed. However, when using basic triggers, the oscilloscope attempts to maintain the same trigger point by changing trigger settings.

Inverting a channel also changes the result of any math function selected in the Waveform Math Menu or any measurement.

## Setting Analog Channel Probe Options

- 1 Click the probe's associated channel number button.
- 2 In the Channel Menu, click **Probe** to display the Channel Probe Menu.

This menu lets you select additional probe parameters such as attenuation factor and units of measurement for the connected probe.



The Channel Probe Menu changes depending on the type of probe connected.

For passive probes (such as the N2862A/B, N2863A/B, N2889A, N2890A, 10073C, 10074C, or 1165A probes), the **Probe Check** softkey appears; it guides you through the process of compensating probes.

For some active probes (such as InfiniiMax probes), the oscilloscope can accurately calibrate its analog channels for the probe. When you connect a probe that can be calibrated, the **Calibrate Probe** softkey appears (and the probe attenuation softkey may change). See ["To calibrate a probe"](#) on page 62.

- See Also**
- ["To specify the channel units"](#) on page 61
  - ["To specify the probe attenuation"](#) on page 61
  - ["To specify the probe skew"](#) on page 62

### To specify the channel units

- 1 Click the probe's associated channel number button.
- 2 In the Channel Menu, click **Probe**.
- 3 In the Channel Probe Menu, click **Units**; then, select:
  - **Volts** – for a voltage probe.
  - **Amps** – for a current probe.

Channel sensitivity, trigger level, measurement results, and math functions will reflect the measurement units you have selected.

### To specify the probe attenuation

The probe attenuation is set automatically if the oscilloscope can identify the connected probe.

The probe attenuation factor must be set properly for accurate measurement results.

If you connect a probe that is not automatically identified by the oscilloscope, you can manually set the attenuation factor as follows:

- 1 Click the channel number button.
- 2 In the Channel Menu, click **Probe**.
- 3 In the Channel Probe Menu, click the **Probe** softkey until you have selected how you want to specify the attenuation factor, choosing either **Ratio** or **Decibels**.
- 4 Click the **Probe** softkey again to open a keypad dialog box where you can set the attenuation factor for the connected probe.

When measuring voltage values, the attenuation factor can be set from 0.001:1 to 10000:1 in a 1-2-5 sequence.

When measuring current values with a current probe, the attenuation factor can be set from 10 V/A to 0.0001 V/A.

When specifying the attenuation factor in decibels, you can select values from -20 dB to 80 dB.

If Amps is chosen as the units and a manual attenuation factor is chosen, then the units as well as the attenuation factor are displayed above the **Probe** softkey.



## To specify the probe skew

When measuring time intervals in the nanoseconds (ns) range, small differences in cable length can affect the measurement. Use **Skew** to remove cable-delay errors between any two channels.

- 1 Probe the same point with both probes.
- 2 Click one of the probe's associated channel number button.
- 3 In the Channel Menu, click **Probe**.
- 4 In the Channel Probe Menu, click **Skew** twice; then, enter the desired skew value.

Each analog channel can be adjusted  $\pm 100$  ns in 10 ps increments for a total of 200 ns difference.

The skew setting is not affected by choosing **Default Setup** or **Autoscale**.

## To calibrate a probe

The **Calibrate Probe** softkey guides you through the process of calibrating probes.

For certain active probes, such as InfiniiMax probes, the oscilloscope can accurately calibrate its analog channels for the probe. When you connect a probe that can be calibrated, the **Calibrate Probe** softkey in the Channel Probe Menu becomes active.

To calibrate one of these probes:

- 1 First, connect your probe to one of the oscilloscope channels.  
This could be, for example, an InfiniiMax probe amplifier/probe head with attenuators attached.
- 2 Connect the probe to the Probe Comp terminal, and the probe ground to the ground terminal.

#### NOTE

When calibrating a differential probe, connect the positive lead to the Probe Comp terminal and the negative lead to the ground terminal. You may need to connect an alligator clip to the ground lug to allow a differential probe to span between the Probe Comp test point and ground. A good ground connection ensures the most accurate probe calibration.

- 3 Click the probe's associated channel number button to turn the channel on (if the channel is off).
- 4 In the Channel Menu, click the **Probe** softkey.
- 5 In the Channel Probe Menu, the second softkey from the left is for specifying your probe head (and attenuation). Repeatedly click this softkey until the probe head selection matches the attenuator you are using.

The choices are:

- 10:1 single-ended browser (no attenuator).
- 10:1 differential browser (no attenuator).
- 10:1 (+6 dB Atten) single-ended browser.
- 10:1 (+6 dB Atten) differential browser.
- 10:1 (+12 dB Atten) single-ended browser.
- 10:1 (+12 dB Atten) differential browser.
- 10:1 (+20 dB Atten) single-ended browser.
- 10:1 (+20 dB Atten) differential browser.

- 6 Click **Calibrate Probe** and follow the instructions on the display.

For more information on InfiniiMax probes and accessories, see the probe's *User's Guide*.





## 4 Math Waveforms

To display math waveforms / 66

To adjust the math waveform scale and offset / 68

Units for Math Waveforms / 69

Math Operators / 70

Math Transforms / 72

Math Filters / 88

Math Visualizations / 91

The Measurement Record and Waveform Math / 94

You can define two math functions. One math function waveform can be displayed at a time. The math function waveform is displayed in light purple.

Math functions can be performed on analog channels or they can be performed on lower math functions when using operators other than add, subtract, multiply, or divide.

## To display math waveforms

- 1 Choose **Main Menu > Analyze > Waveform Math** to display the Waveform Math Menu.



- 2 Click **Display Math** to select the math function you want to display. Then, click **Display Math** again to display the selected math function.
- 3 Use the **Operator** softkey to select an operator, transform, filter, or visualization.

For more information on the operators, see:

- **"Math Operators"** on page 70
  - **"Math Transforms"** on page 72
  - **"Math Filters"** on page 88
  - **"Math Visualizations"** on page 91
- 4 Click the **Source 1** softkey to select the analog channel, lower math function, or reference waveform on which to perform math.

Higher math functions can operate on lower math functions when using operators other than the simple arithmetic operations (+, -, \*, /). For example, if **Math 1** is set up as a subtract operation between channels 1 and 2, the **Math 2** function could be set up as a FFT operation on the Math 1 function. These are called cascaded math functions.

To cascade math functions, select the lower math function using the **Source 1** softkey.

### TIP

When cascading math functions, to get the most accurate results, be sure to vertically scale lower math functions so that their waveforms take up the full screen without being clipped.

- 5 If you selected an arithmetic operator for the math function, use the **Source 2** softkey to select the second source for the arithmetic operation.
- 6 To re-size and re-position the math waveform, see **"To adjust the math waveform scale and offset"** on page 68.

**TIP****Math Operating Hints**

If the analog channel or math function is clipped (not fully displayed on screen) the resulting displayed math function will also be clipped.

Once the function is displayed, the analog channel(s) may be turned off for better viewing of the math waveform.

The vertical scaling and offset of each math function can be adjusted for ease of viewing and measurement considerations.

The math function waveform can be measured using cursors and/or measurements.

---

## To adjust the math waveform scale and offset

- 1 Click the Scale and/or Offset buttons in the Waveform Math Menu.
- 2 Use the dialog box controls to make adjustments.

### NOTE

#### **Math Scale and Offset are Set Automatically**

Any time the currently displayed math function definition is changed, the function is automatically scaled for optimum vertical scale and offset. If you manually set scale and offset for a function, select a new function, then select the original function, the original function will be automatically rescaled.

---

See Also · ["Units for Math Waveforms"](#) on page 69

## Units for Math Waveforms

Units for each input channel can be set to Volts or Amps using the **Units** softkey in the channel's Probe Menu. Units for math function waveforms are:

Math function	Units
add or subtract	V or A
multiply	$V^2$ , $A^2$ , or W (Volt-Amp)
d/dt	V/s or A/s (V/second or A/second)
$\int dt$	Vs or As (V-seconds or A-seconds)
FFT	See " <b>FFT Units</b> " on page 81.
$\sqrt{\text{square root}}$	$V^{1/2}$ , $A^{1/2}$ , or $W^{1/2}$ (Volt-Amp)

A scale unit of **U** (undefined) will be displayed for math functions when two source channels are used and they are set to dissimilar units and the combination of units cannot be resolved.

## Math Operators

Math operators perform arithmetic operations (like add, subtract, or multiply) on analog input channels.

- **"Add or Subtract"** on page 70
- **"Multiply or Divide"** on page 71

### Add or Subtract

When you select add or subtract, the **Source 1** and **Source 2** values are added or subtracted point by point, and the result is displayed.

You can use subtract to make a differential measurement or to compare two waveforms.

If your waveforms' DC offsets are larger than the dynamic range of the oscilloscope's input channels you will need to use a differential probe instead.

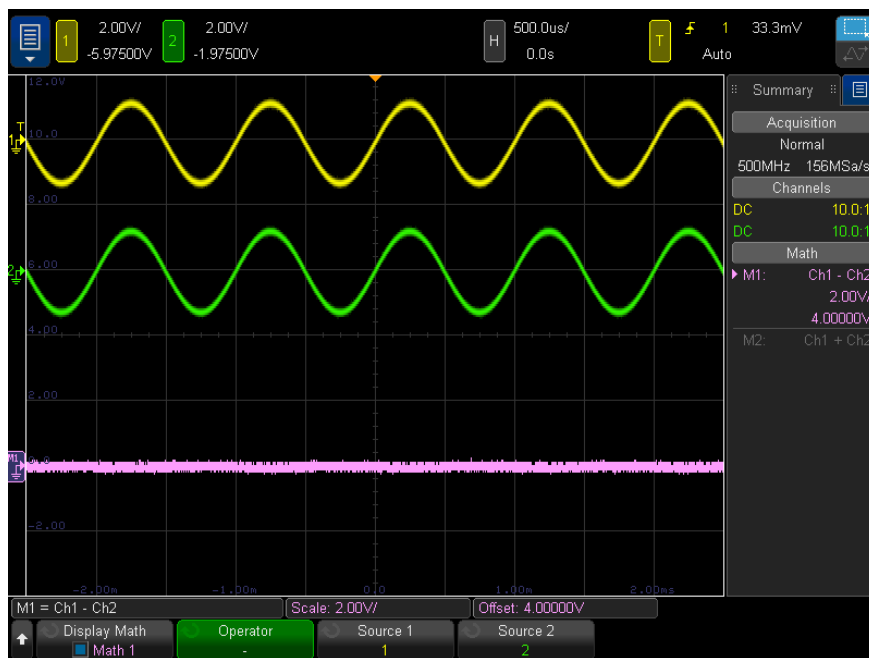

**Figure 4** Example of Subtract Channel 2 from Channel 1

See Also • **"Units for Math Waveforms"** on page 69

## Multiply or Divide

When you select the multiply or divide math function, the **Source 1** and **Source 2** values are multiplied or divided point by point, and the result is displayed.

The divide by zero case places holes (that is, zero values) in the output waveform.

Multiply is useful for seeing power relationships when one of the channels is proportional to the current.



**Figure 5** Example of Multiply Channel 1 by Channel 2

See Also · ["Units for Math Waveforms"](#) on page 69

## Math Transforms

Math transforms perform a transform function (like differentiate, integrate, FFT, or square root) on an analog input channel or on the result of an arithmetic operation.

- **"Differentiate"** on page 72
- **"Integrate"** on page 73
- **"FFT Magnitude, FFT Phase"** on page 75
- **"Square Root"** on page 83
- **"Ax + B"** on page 83
- **"Square"** on page 84
- **"Absolute Value"** on page 84
- **"Common Logarithm"** on page 85
- **"Natural Logarithm"** on page 85
- **"Exponential"** on page 86
- **"Base 10 Exponential"** on page 86

### Differentiate

**d/dt** (differentiate) calculates the discrete time derivative of the selected source.

You can use differentiate to measure the instantaneous slope of a waveform. For example, the slew rate of an operational amplifier may be measured using the differentiate function.

Because differentiation is very sensitive to noise, it is helpful to set acquisition mode to **Averaging** (see **"Selecting the Acquisition Mode"** on page 184).

**d/dt** plots the derivative of the selected source using the "average slope estimate at 4 points" formula. The equation is:

$$d_i = \frac{y_{i+4} + 2y_{i+2} - 2y_{i-2} - y_{i-4}}{8 \Delta t}$$

Where:

- d = differential waveform.
- y = channel 1, 2, or Math 1 (lower math function) data points.
- i = data point index.
- $\Delta t$  = point-to-point time difference.



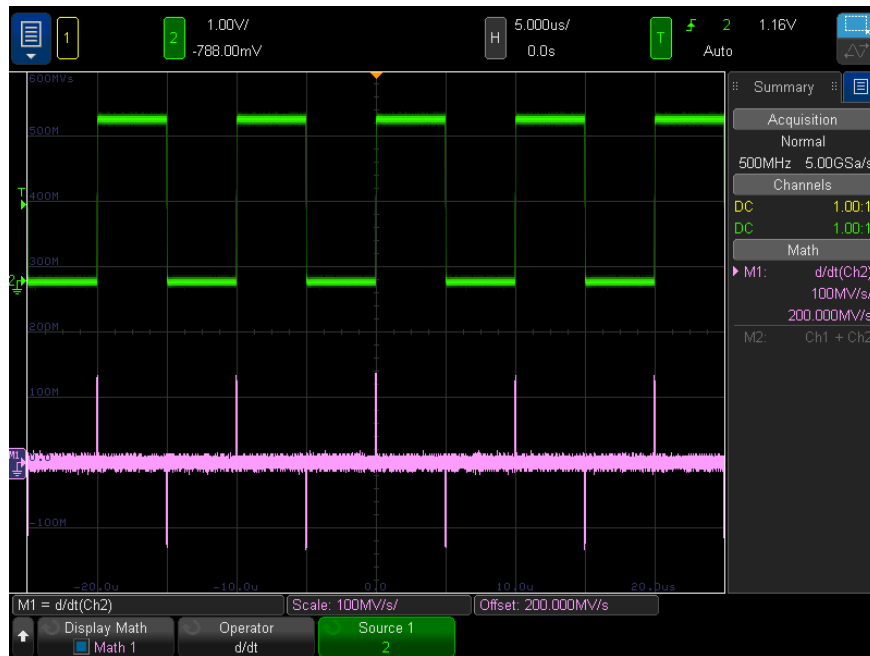

**Figure 6** Example of Differentiate Function

See Also • ["Units for Math Waveforms"](#) on page 69

## Integrate

∫ dt (integrate) calculates the integral of the selected source. It shows the accumulated amount of change.

You can use integrate to calculate the energy of a pulse in volt-seconds or measure the area under a waveform by measuring the difference in the integrate function value across the pulse or waveform.

∫ dt plots the integral of the source using the "Trapezoidal Rule". The equation is:

$$I_n = c_o + \Delta t \sum_{i=0}^n y_i$$

Where:

- I = integrated waveform.
- Δt = point-to-point time difference.
- y = channel 1, 2, or Math 1 (lower math function) data points.
- c<sub>o</sub> = arbitrary constant.
- i = data point index.

The integrate operator provides an **Offset** softkey that lets you enter a DC offset correction factor for the input signal. Small DC offset in the integrate function input (or even small oscilloscope calibration errors) can cause the integrate function output to "ramp" up or down. This DC offset correction lets you level the integrate waveform.

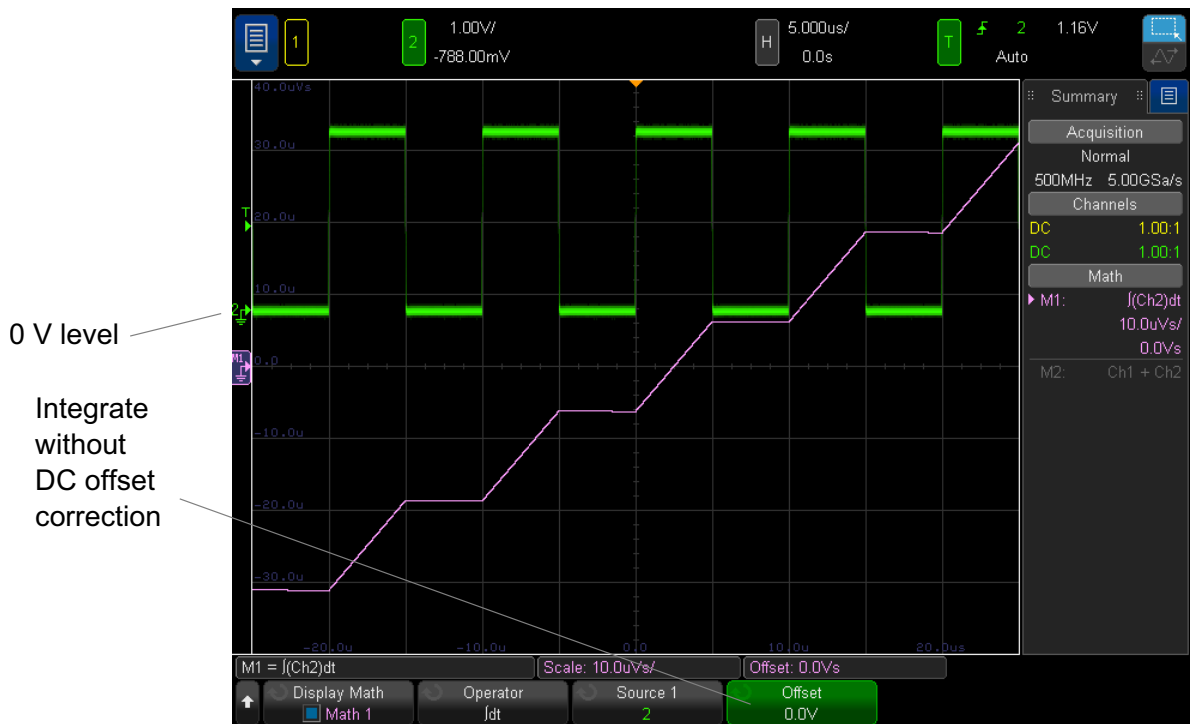
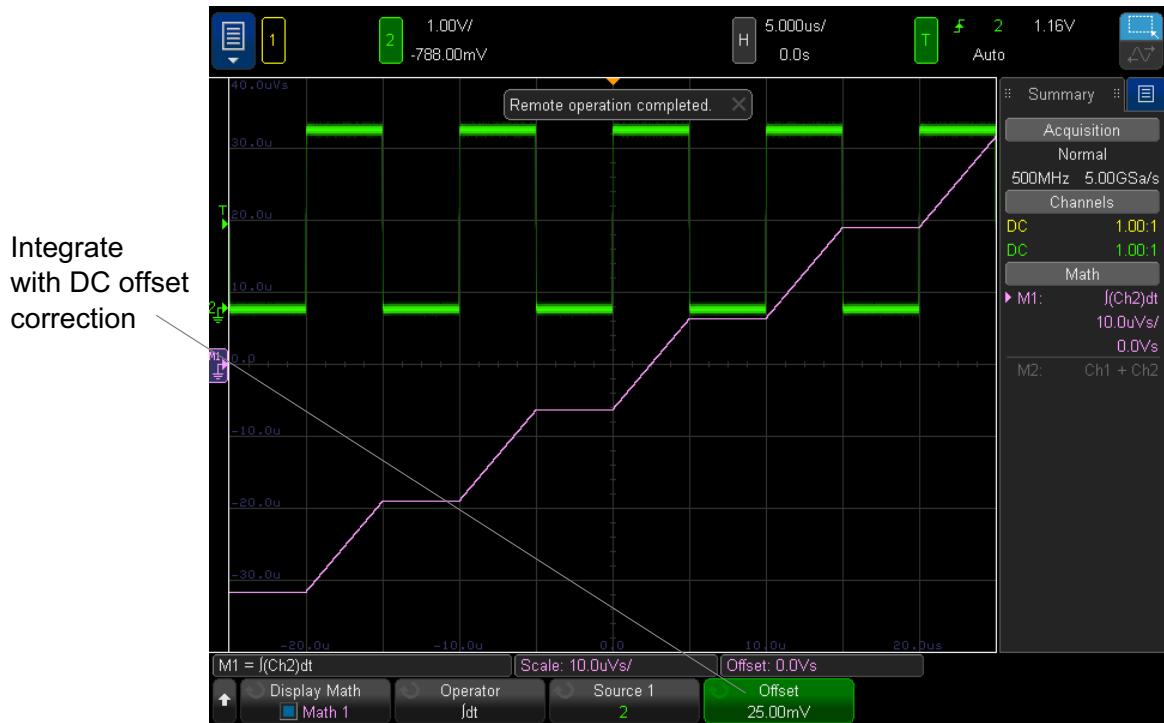

Figure 7 Integrate Without Signal Offset



**Figure 8** Integrate With Signal Offset

See Also • ["Units for Math Waveforms"](#) on page 69

## FFT Magnitude, FFT Phase

Using the Fast Fourier Transform (FFT), the FFT (Magnitude) math function displays the magnitudes of the frequency content that makes up the source waveform, and the FFT (Phase) math function shows the phase relationships of the frequency content. The FFT takes the digitized time record of the specified source and transforms it to the frequency domain.

The source of the FFT math functions can be analog input channels or a lower math function.

The horizontal axis of FFT math functions is frequency (Hertz). For the FFT (Magnitude) math function, the vertical axis is in decibels when Logarithmic vertical units are selected or V RMS when Linear vertical units are selected. For the FFT (Phase) math function, the vertical axis is in degrees or radians.

Use the FFT (Magnitude) function to find crosstalk problems, to find distortion problems in analog waveforms caused by amplifier non-linearity, or for adjusting analog filters.

To display a FFT waveform:

- 1 Choose **Main Menu > Analyze > Waveform Math** to display the Waveform Math Menu.
- 2 Click **Display Math** and select the math function you want to display. Then, click **Display Math** again to display the selected math function.
- 3 Click **Operator** and select **FFT (Magnitude)** or **FFT (Phase)**.



- **Source 1** – selects the source for the FFT.
- **Span/Center** or **Start Freq/Stop Freq** – this pair of softkeys let you define the displayed frequency range. Click the softkeys to toggle between:
  - **Span/Center** – **Span** specifies the frequency range represented by the width of the display. Divide span by 10 to calculate the frequency scale per division. **Center** specifies the frequency at the center vertical grid line of the display.
  - **Start Freq/Stop Freq** – **Start Freq** specifies the frequency at the left side of the display. **Stop Freq** specifies the frequency at the right side of the display.

To set desired values, click the softkey label for a keypad entry dialog box.

- **Scale** – opens a dialog box for adjusting the math waveform's vertical scale.
  - **Offset** – opens a dialog box for adjusting the math waveform's vertical offset.
  - **Bin Size, RBW** (Resolution Bandwidth), **Sample Rate** – displays the FFT resolution in one of three different ways.
  - **More FFT** – displays the More FFT Settings Menu.
- 4 Click **More FFT** to display additional FFT settings.



- **Window**– selects a window to apply to your FFT input signal:
  - **Hanning** – window for making accurate frequency measurements or for resolving two frequencies that are close together.
  - **Flat Top** – window for making accurate amplitude measurements of frequency peaks.
  - **Rectangular** – good frequency resolution and amplitude accuracy, but use only where there will be no leakage effects. Use on self-windowing waveforms such as pseudo-random noise, impulses, sine bursts, and decaying sinusoids.

- **Blackman Harris** – window reduces time resolution compared to a rectangular window, but improves the capacity to detect smaller impulses due to lower secondary lobes.
- **Bartlett** – (triangular, with end points at zero) window is similar to the Hanning window in that it is good for making accurate frequency measurements, but its higher and wider secondary lobes make it not quite as good for resolving frequencies that are close together.
- **Vertical Units** – For FFT (Magnitude), you can select **Logarithmic** (decibels) or **Linear** (V RMS). For FFT (Phase), you can select **Degrees** or **Radians**.

To adjust the FFT waveform vertical scale and offset, click the Scale and Offset buttons in the Waveform Math Menu.

- **FFT Gating**– When the zoomed time base is displayed, click this softkey to select:
  - **No Gating** – the FFT is performed on the source waveform in the upper Main time base window.
  - **Gate By Zoom** – the FFT is performed on the source waveform in the lower Zoom window.
- **Detection Type**– When the FFT (Magnitude) operator is selected, this softkey lets you set the FFT detector decimation type.

Detectors give you a way of manipulating the acquired data to emphasize different features of the data. Detectors reduce (decimate) the number of FFT points to at most the number of specified detector points. In this reduction, sampled FFT points are bucketized, that is, split into a number of groups that equals the specified number of detector points. Then, the points in each bucket are reduced to a single point according to the selected detection type. The detector types are:

- **None** – No detector is used.
- **Sample** – Takes the point nearest to the center of every bucket.
- **+ Peak** – Takes the most positive point in every bucket.
- **- Peak** – Takes the most negative point in every bucket.
- **Average** – Takes the average of all points in every bucket.
- **Normal** – Implements a rosenfell algorithm. This method to picks either the minimum or maximum sample in every bucket depending on whether the data is monotonically increasing, decreasing, or varying. For details, see the [Spectrum Analysis Basics application note](http://www.keysight.com) at [www.keysight.com](http://www.keysight.com).

When detectors are used, the FFT's output is decimated, and any analysis is performed on the reduced or detected data set.

- **Points per Span** – When the FFT (Magnitude) operator is selected and a detector is used, this softkey specifies the maximum number of points that detectors should decimate to. This is also the number of buckets that sampled FFT points are grouped into before the selected detection type reduction (decimation) is applied.

The minimum number of points is 640.

The maximum number of points is the measurement record limit of 64K.

- **Auto Setup** – Sets the frequency Span and Center to values that will cause the entire available spectrum to be displayed. The maximum available frequency is half the FFT sample rate, which is a function of the time per division setting. The FFT resolution is the quotient of the sampling rate and the number of FFT points ( $f_s/N$ ). The current FFT Resolution is displayed above the softkeys.
- **Zero Phase Ref** – When the FFT (Phase) operator is selected, this softkey sets the reference point for calculating the FFT Phase function:
  - **Trigger** – the FFT phase is measured from the trigger (time=0) point of the waveform.
  - **Entire Display** – the FFT phase is measured from the beginning of the displayed waveform.

## NOTE

### Scale and offset considerations

If you do not manually change the FFT scale or offset settings, when you adjust the horizontal scale, the span and center frequency settings will automatically change to allow optimum viewing of the full spectrum.

If you do manually set scale or offset, adjusting the horizontal scale will not change the span or center frequency settings, allowing you see better detail around a specific frequency.

Clicking the FFT **Auto Setup** softkey will automatically rescale the waveform and span and center will again automatically track the horizontal scale setting.

- 5 To make cursor measurements, choose **Main Menu > Measure > Cursors** and set the **Source** softkey to **Math N**.

Use the X1 and X2 cursors to measure frequency values and difference between two frequency values ( $\Delta X$ ). Use the Y1 and Y2 cursors to measure amplitude in dB and difference in amplitude ( $\Delta Y$ ).

- 6 To make other measurements, choose **Main Menu > Measure > Measurements**, click **Add Meas**, and set the **Source** softkey to **Math N**.

You can make peak-to-peak, maximum, minimum, and average dB measurements on the FFT waveform. You can also find the frequency value at the first occurrence of the waveform maximum by using the X at Max Y measurement.

The following FFT (Magnitude) spectrum was obtained by connecting a 2.5 V, 100 kHz square wave to channel 1. Set the horizontal scale to 50  $\mu\text{s}/\text{div}$ , vertical sensitivity to 1 V/div, Units/div to 20 dBV, Offset to -40.0 dBV, Center frequency to 500 kHz, frequency Span to 1 MHz, and window to Hanning.



- See Also
- ["Searching for FFT Peaks"](#) on page 79
  - ["FFT Measurement Hints"](#) on page 80
  - ["FFT Units"](#) on page 81
  - ["FFT DC Value"](#) on page 81
  - ["FFT Aliasing"](#) on page 81
  - ["FFT Spectral Leakage"](#) on page 83
  - ["Units for Math Waveforms"](#) on page 69

### Searching for FFT Peaks

To search for FFT math function frequency peaks:

- 1 Choose **Main Menu > Analyze > Waveform Search**.
- 2 In the Search Menu, click **Search**; then, select **Frequency Peaks**.
- 3 Click **Source** and select the FFT math function waveform to search.
- 4 Click **Max # Peaks** and specify the maximum number of FFT peaks to find.
- 5 Click **Threshold** and specify the threshold level necessary to be considered a peak.

- 6 Click **Excursion** to specify the amplitude above the FFT waveform's noise floor necessary to be recognized as a peak.

Note that the FFT waveform's noise floor level differs when additional math functions are applied to the FFT:

- When **Averaged Value**, **Max Hold**, or **Min Hold** are applied, the FFT waveform's noise floor is more stable, and excursion level settings are more accurate.
- When no additional math functions are applied (normal), the FFT waveform's noise floor is less stable and excursion level settings are less accurate.

White arrowheads at the top of the graticule show where FFT peaks are found.

When acquisitions are stopped, you can use the sidebar **Navigate** controls and cursors to look at the search events found.

### FFT Measurement Hints

The number of points acquired for the FFT record can be up to 65,536, and when frequency span is at maximum, all points are displayed. Once the FFT spectrum is displayed, the frequency span and center frequency controls are used much like the controls of a spectrum analyzer to examine the frequency of interest in greater detail. Place the desired part of the waveform at the center of the screen and decrease frequency span to increase the display resolution. As frequency span is decreased, the number of points shown is reduced, and the display is magnified.

While the FFT spectrum is displayed, use the Waveform Math Menu and Cursors Menu to switch between measurement functions and frequency domain controls in FFT Menu.

#### NOTE

#### FFT Resolution

The FFT resolution is the quotient of the sampling rate and the number of FFT points ( $f_s/N$ ). With a fixed number of FFT points, the lower the sampling rate, the better the resolution.

Decreasing the effective sampling rate by selecting a greater time/div setting will increase the low frequency resolution of the FFT display and also increase the chance that an alias will be displayed. The resolution of the FFT is the effective sample rate divided by the number of points in the FFT. The actual resolution of the display will not be this fine as the shape of the window will be the actual limiting factor in the FFT's ability to resolve two closely spaced frequencies. A good way to test the ability of the FFT to resolve two closely spaced frequencies is to examine the sidebands of an amplitude modulated sine wave.

For the best vertical accuracy on peak measurements:

- Make sure the probe attenuation is set correctly. The probe attenuation is set from the Channel Menu if the operand is a channel.



- Set the source sensitivity so that the input signal is near full screen, but not clipped.
- Use the Flat Top window.
- Set the FFT sensitivity to a sensitive range, such as 2 dB/division.

For best frequency accuracy on peaks:

- Use the Hanning window.
- Use Cursors to place an X cursor on the frequency of interest.
- Adjust frequency span for better cursor placement.
- Return to the Cursors Menu to fine tune the X cursor.

For more information on the use of FFTs please refer to Keysight Application Note 243, *The Fundamentals of Signal Analysis* at

<http://literature.cdn.keysight.com/litweb/pdf/5952-8898E.pdf>. Additional information can be obtained from Chapter 4 of the book *Spectrum and Network Measurements* by Robert A. Witte.

### FFT Units

**FFT (Magnitude) Units** 0 dBV is the amplitude of a 1 V<sub>rms</sub> sinusoid.

When the FFT source is channel 1 or channel 2:

- FFT units will be displayed in dBV when channel units is set to Volts and channel impedance is set to 1 M $\Omega$  or the probe attenuation setting is something other than 1:1.
- FFT units will be displayed in dBm when channel units is set to Volts, channel impedance is set to 50 $\Omega$ , and the probe attenuation setting is 1:1.

For all other FFT sources or when a source channel's units has been set to Amps, FFT units will be displayed as dB.

**FFT (Phase) Units** In this case, the vertical units are degrees or radians.

### FFT DC Value

The FFT computation produces a DC value that is incorrect. It does not take the offset at center screen into account. The DC value is not corrected in order to accurately represent frequency components near DC.

### FFT Aliasing

When using FFTs, it is important to be aware of frequency aliasing. This requires that the operator have some knowledge as to what the frequency domain should contain, and also consider the sampling rate, frequency span, and oscilloscope vertical bandwidth when making FFT measurements. The FFT resolution (the quotient of the sampling rate and the number of FFT points) is displayed directly above the softkeys when the FFT Menu is displayed.

**NOTE****Nyquist Frequency and Aliasing in the Frequency Domain**

The Nyquist frequency is the highest frequency that any real-time digitizing oscilloscope can acquire without aliasing. This frequency is half of the sample rate. Frequencies above the Nyquist frequency will be under sampled, which causes aliasing. The Nyquist frequency is also called the folding frequency because aliased frequency components fold back from that frequency when viewing the frequency domain.

Aliasing happens when there are frequency components in the signal higher than half the sample rate. Because the FFT spectrum is limited by this frequency, any higher components are displayed at a lower (aliased) frequency.

The following figure illustrates aliasing. This is the spectrum of a 990 Hz square wave, which has many harmonics. The horizontal time/div setting for the square wave sets the sample rate and results in a FFT resolution of 3 Hz. The displayed FFT spectrum waveform shows the components of the input signal above the Nyquist frequency to be mirrored (aliased) on the display and reflected off the right edge.

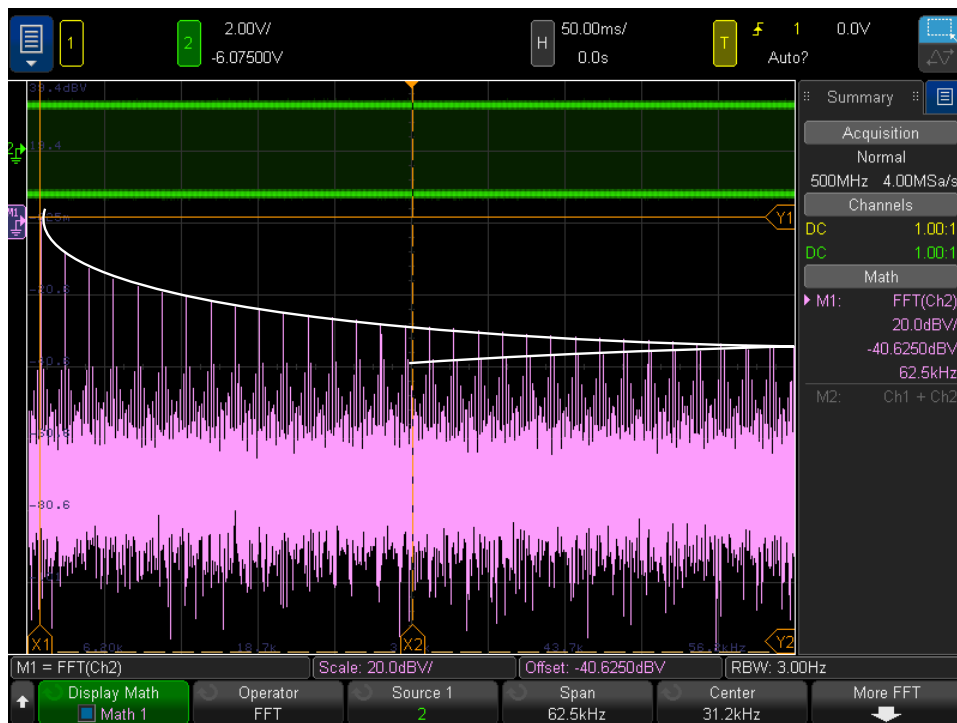

**Figure 9** Aliasing

Because the frequency span goes from  $\approx 0$  to the Nyquist frequency, the best way to prevent aliasing is to make sure that the frequency span is greater than the frequencies of significant energy present in the input signal.

## FFT Spectral Leakage

The FFT operation assumes that the time record repeats. Unless there is an integral number of cycles of the sampled waveform in the record, a discontinuity is created at the end of the record. This is referred to as leakage. In order to minimize spectral leakage, windows that approach zero smoothly at the beginning and end of the signal are employed as filters to the FFT. The FFT Menu provides these windows: Hanning, Flat Top, Rectangular, Blackman-Harris, and Bartlett. For more information on leakage, see Keysight Application Note 243, *The Fundamentals of Signal Analysis* at

<http://literature.cdn.keysight.com/litweb/pdf/5952-8898E.pdf>.

## Square Root

Square root ( $\sqrt{\quad}$ ) calculates the square root of the selected source.

Where the transform is undefined for a particular input, holes (zero values) appear in the function output.

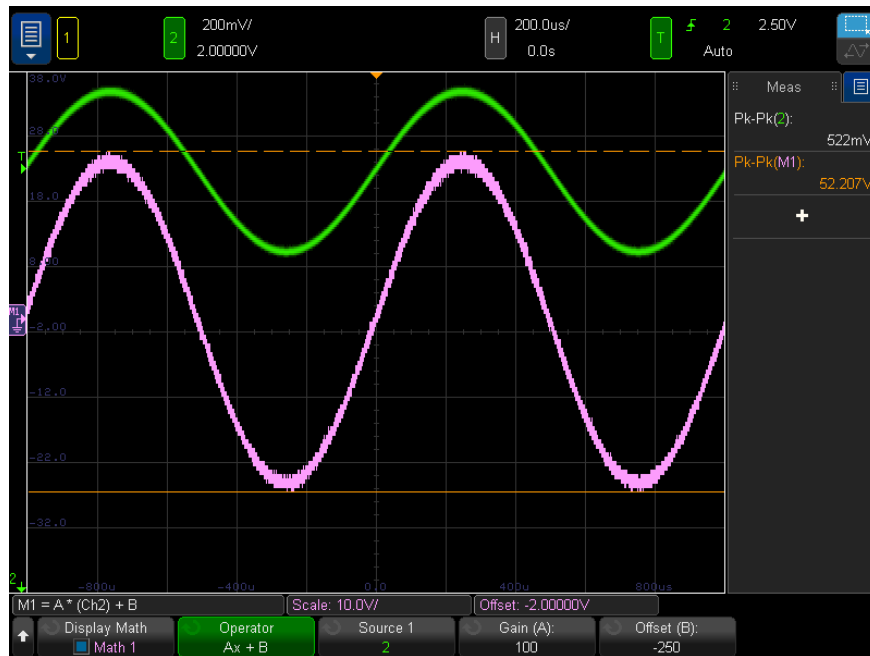

**Figure 10** Example of  $\sqrt{\quad}$  (Square Root)

See Also · ["Units for Math Waveforms"](#) on page 69

## Ax + B

The Ax + B function lets you apply a gain and offset to an existing input source.



**Figure 11** Example of  $Ax + B$

Use the **Gain (A)** softkey to specify the gain.

Use the **Offset (B)** softkey to specify the offset.

The  $Ax + B$  function differs from the Magnify math visualization function in that the output is likely different than the input.

**See Also** • **"Magnify"** on page 91

## Square

The square function calculates the square of the selected source, point by point, and displays the result.

Press the **Source** softkey to select the signal source.

**See Also** • **"Square Root"** on page 83

## Absolute Value

The absolute value function changes negative values in the input to positive values and displays the resulting waveform.

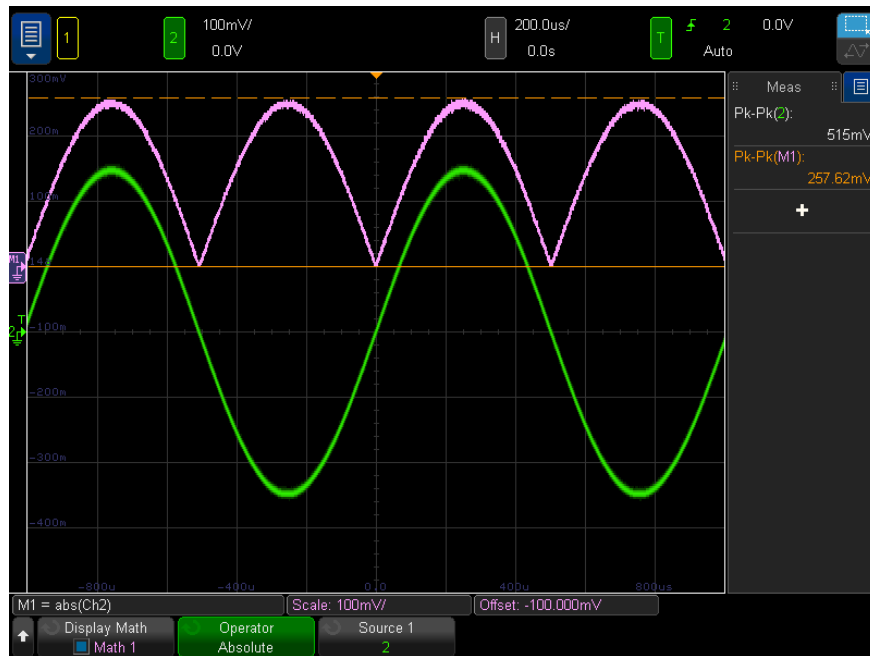

**Figure 12** Example of Absolute Value

See Also • **"Square"** on page 84

## Common Logarithm

The Common Logarithm (log) function performs a transform of the input source. Where the transform is undefined for a particular input, holes (zero values) appear in the function output.

See Also • **"Natural Logarithm"** on page 85

## Natural Logarithm

The Natural Logarithm (ln) function performs a transform of the input source. Where the transform is undefined for a particular input, holes (zero values) appear in the function output.



**Figure 13** Example of Natural Logarithm

See Also · ["Common Logarithm"](#) on page 85

### Exponential

The Exponential ( $e^x$ ) function performs a transform of the input source.

See Also · ["Base 10 Exponential"](#) on page 86

### Base 10 Exponential

The Base 10 Exponential ( $10^x$ ) function performs a transform of the input source.

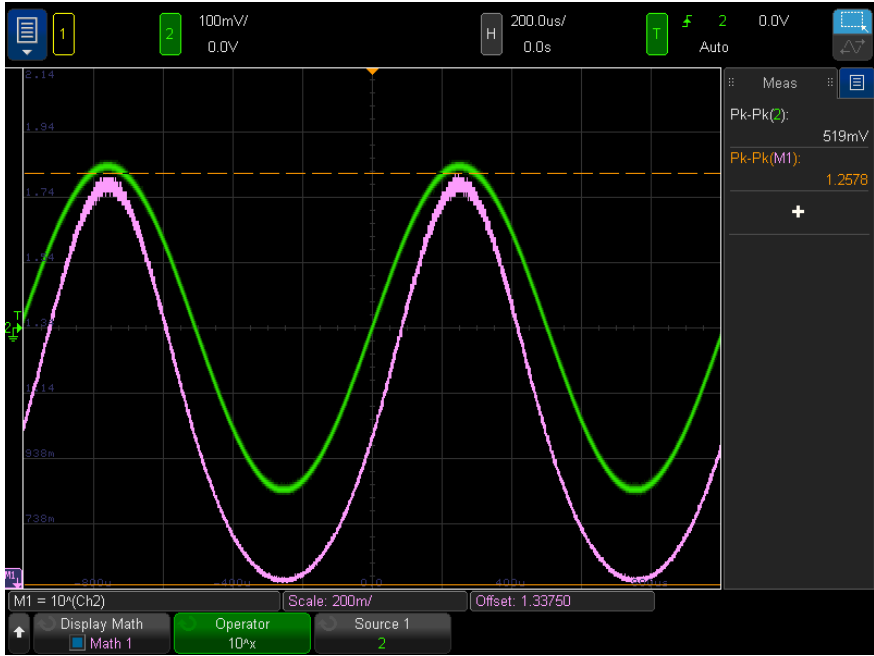

Figure 14 Example of Base 10 Exponential

See Also · "Exponential" on page 86

## Math Filters

You can use math filters to create a waveform that is the result of a the filter on an analog input channel or on the result of an arithmetic operation.

- **"High Pass and Low Pass Filter"** on page 88
- **"Averaged Value"** on page 89
- **"Smoothing"** on page 90
- **"Envelope"** on page 90

### High Pass and Low Pass Filter

The high-pass or low-pass filter functions apply the filter to the selected source waveform and display the result in the math waveform.

The high-pass filter is a single-pole high-pass filter.

The low-pass filter is a 4th order Bessel-Thompson filter.

Use the **Band width** softkey to select the filter's -3 dB cutoff frequency.

#### NOTE

The ratio of the input signal's Nyquist frequency and the selected -3 dB cutoff frequency affects how many points are available in the output, and under some circumstances, there are no points in the output waveform.

---





**Figure 15** Example of Low Pass Filter

## Averaged Value

When the Averaged Value operator is selected, the math waveform becomes the selected source waveform, averaged the selected number of times.

The source waveform can be one of the analog input channels or one of the previous math function waveforms.

Unlike acquisition averaging, the math averaging operator can be used to average the data on a single analog input channel or math function.

If acquisition averaging is also used, the analog input channel data is averaged and the math function averages it again. You can use both types of averaging to get a certain number of averages on all waveforms and an increased number of averages on a particular waveform.

As with acquisition averaging, averages are calculated using a "decaying average" approximation, where:

$$\text{next\_average} = \text{current\_average} + (\text{new\_data} - \text{current\_average})/N$$

Where N starts at 1 for the first acquisition and increments for each following acquisition until it reaches the selected number of averages, where it holds.

Press the **Reset Count** softkey to clear the number of waveforms evaluated.

See Also • ["Averaging Acquisition Mode"](#) on page 187

## Smoothing

The resulting math waveform is the selected source with a normalized rectangular (boxcar) FIR filter applied.

The boxcar filter is a moving average of adjacent waveform points, where the number of adjacent points is specified by the **Smoothing Points** softkey. You can choose an odd number of points, from 3 up to half of the measurement record.

The smoothing operator limits the bandwidth of the source waveform. The smoothing operator can be used, for example, to smooth measurement trend waveforms.

## Envelope

The resulting math waveform shows the amplitude envelope for an amplitude modulated (AM) input signal.

This function uses a Hilbert transform to get the real (in-phase, I) and imaginary (quadrature, Q) parts of the input signal and then performs a square root of the sum of the real and imaginary parts to get the demodulated amplitude envelope waveform.

## Math Visualizations

You can apply visualization math functions that give you different ways of viewing captured data and measurement values.

- **"Magnify"** on page 91
- **"Maximum/Minimum"** on page 92
- **"Peak-Peak"** on page 92
- **"Max/Min Hold"** on page 92
- **"Measurement Trend"** on page 92

### Magnify

The magnify math function lets you display an existing input source at different vertical settings to provide more vertical detail.

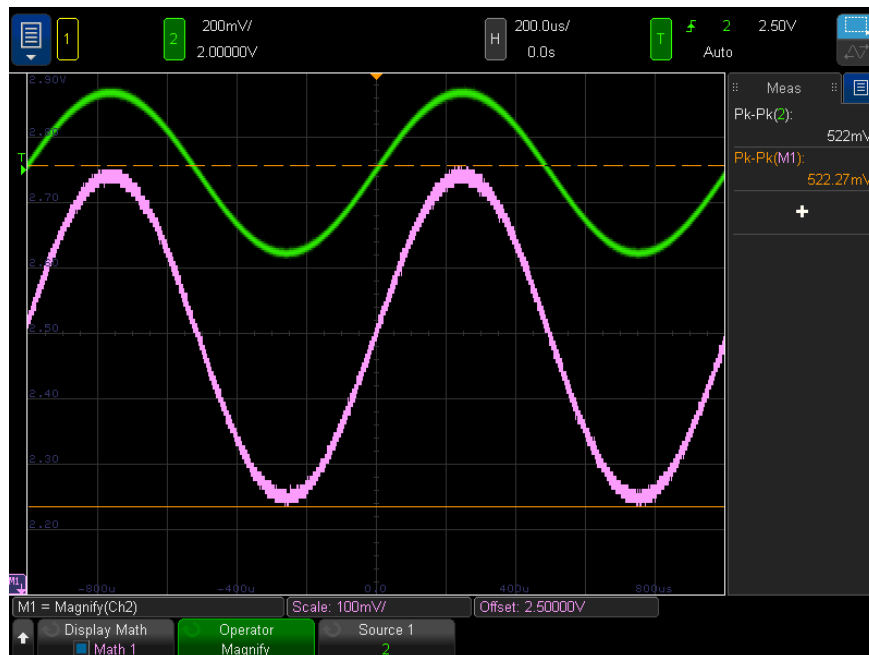

**Figure 16** Example of Magnify

See Also • **"Ax + B"** on page 83

## Maximum/Minimum

The Maximum operator is like the Max Hold operator without the hold. The maximum vertical values found at each horizontal bucket are used to build a waveform.

The Minimum operator is like the Min Hold operator without the hold. The minimum vertical values found at each horizontal bucket are used to build a waveform.

## Peak-Peak

The Peak-Peak operator is like the Maximum operator minus the Minimum operator. At each horizontal bucket, the minimum vertical values found are subtracted from the maximum vertical values found to build a waveform.

## Max/Min Hold

The Max Hold operator records the maximum vertical values found at each horizontal bucket across multiple analysis cycles and uses those values to build a waveform.

The Min Hold operator is the same, except it records the minimum vertical values.

When not used in a frequency analysis domain, these functions are often referred to as Max Envelope and Min Envelope.

Press the **Reset Count** softkey to clear the number of waveforms evaluated.

## Measurement Trend

The measurement trend math function shows measurement values for a waveform (based on measurement threshold settings) as the waveform progresses across the screen. For every cycle, a measurement is made, and the value is displayed on the screen for the cycle.



**Figure 17** Example of Measurement Trend

Press the **Measurement** softkey to select the previously added measurement whose trend you want to look at. You can display trend values for these measurements:

- Average
- RMS - AC
- Ratio
- Period
- Frequency
- +Width
- -Width
- +Duty Cycle
- -Duty Cycle
- Rise Time
- Fall Time

Use the **Thresholds** softkey to access the Measurement Threshold Menu. See "**Measurement Thresholds**" on page 230.

If a measurement cannot be made for part of a waveform, the trend function output is a hole (that is, no value) until a measurement can be made.

## The Measurement Record and Waveform Math

Keysight InfiniiVision oscilloscopes are designed to provide high *waveform update rates* which give you an increased probability of capturing infrequent events. With high waveform update rates, there is less "*dead time*" between acquisitions.

To provide high waveform update rates, there are some things the oscilloscope does with memory:

- When running, acquisition memory is split into two memories so that the processing of one acquisition can take place while another acquisition is being captured. For single acquisitions, the full memory is used. Waveform data in acquisition memory is called the *raw acquisition record*.
- There is a separate 65536 (64K) points maximum of *eavesdrop memory* that is used for making measurements and for calculating math functions. Data in this memory is a reduced-sample decimation of the data in the raw acquisition record. When a math function is turned on, eavesdrop memory is limited to 62500 points maximum. Waveform data in eavesdrop memory is called the *measurement record*.

(If you want to calculate math functions on a longer record, you can save the raw acquisition record and use programs like Excel or MATLAB to perform the analysis.)

Waveform data for the acquisition time (that is, the time per division setting multiplied by 10 divisions across the display) is saved to the memories. When the oscilloscope analog-to-digital converter's (ADC, or digitizer) sample period yields more data points than can be stored in the memory, some samples are thrown away (decimated), and the effective (or actual) sample rate is reduced. This is why, at greater time/div settings, the displayed sample rate decreases.

For example, suppose an oscilloscope's digitizer has a sample period of 1 ns (maximum sample rate of 1 GSa/s) and a 1 M memory depth. At that rate, memory is filled in 1 ms. If the acquisition time is 100 ms (10 ms/div), only 1 of every 100 samples is needed to fill memory. The effective sample rate becomes 10 MSa/s.

The decimator is configured to provide a best-estimate of all the samples that each point in the record represents. There is no filtering in the decimation.

### FFT (Spectral) Analysis of Measurement Record Data

When the FFT operator is turned on, the decimation from the raw acquisition record to the measurement record works on integer rate down-sampling. For example, a raw acquisition record of 2000000 points and a measurement record of 62500 points are already set up with an integer rate decimation of 32 (2000000/32 = 62500).

For FFT analysis, the decimated record is then zero-padded to  $2^{(X+1)}$  where  $2^X \geq$  record length. For the above example, the power of 2 greater than the record length is 65536, so the record is zero-padded to 131072 points.

You can look at the FFT math function results on the oscilloscope to work backward and find the un-zero-padded decimated record length as well as the FFT length used after the zero-padding:

- First, we know:
  - The FFT algorithm translates a time record of  $N$  equally spaced samples into  $N/2$  equally spaced lines in the frequency domain.
  - The width of the FFT on the display is the maximum frequency in the FFT. The maximum FFT frequency is also  $f_S/2$ , where  $f_S$  is the effective sample rate of the decimated data. (Use the center/span or start/stop frequency controls to display the maximum FFT frequency.)
  - The FFT Resolution is displayed in the FFT menu. FFT resolution is also known as the FFT bin width or a line in the frequency domain.
- Therefore, the un-zero-padded decimated record length is:  $f_S \times$  the acquisition time (or  $2 \times$  max FFT freq  $\times$  acquisition time).
- Also, the FFT length used after the zero-padding is:  $2 \times$  (maximum FFT frequency)/(FFT Resolution).

For more information on FFT transformation, see Keysight Application Note 243, *The Fundamentals of Signal Analysis* at

<http://literature.cdn.keysight.com/litweb/pdf/5952-8898E.pdf>.





## 5 Reference Waveforms

To save a waveform to a reference waveform location / 98

To display a reference waveform / 99

To display reference waveform information / 100

To scale and position reference waveforms / 101

To adjust reference waveform skew / 102

To save/recall reference waveform files / 103

Analog channel or math waveforms can be saved to one of two reference waveform locations in the oscilloscope. Then, a reference waveform can be displayed and compared against other waveforms. One reference waveform can be displayed at a time.

When the reference waveform information is displayed, you can click on the scale and offset values to adjust them. There is also a skew adjustment for reference waveforms.

Analog channel, math, or reference waveforms can be saved to a reference waveform file on the chassis controller PC. You can recall a reference waveform file into one of the reference waveform locations.

## To save a waveform to a reference waveform location

- 1 Choose **Main Menu > Sources > Reference Waveforms** to turn on reference waveforms.
- 2 In the Reference Waveform Menu, click **Display Ref** to select the desired reference waveform location you want to display. Then, click **Display Ref** again to display the selected reference waveform location.
- 3 Click the **Source** to select the source waveform.
- 4 Click **Save to R1/R2** to save the waveform to the reference waveform location.

### NOTE

Reference waveforms are non-volatile – they remain after power cycling or performing a default setup.

### To clear a reference waveform location

- 1 Choose **Main Menu > Sources > Reference Waveforms** to turn on reference waveforms.
- 2 In the Reference Waveform Menu, click **Display Ref** to select the desired reference waveform location.
- 3 Click **Clear R1/R2** to clear the reference waveform location.

Reference waveforms are also cleared by a Factory Default (see [Chapter 18](#), “Save/Email/Recall (Setups, Screens, Data),” starting on page 281).

To display a reference waveform

- 1 Choose **Main Menu > Sources > Reference Waveforms** to turn on reference waveforms.
- 2 In the Reference Waveform Menu, click **Display Ref** to select the desired reference waveform location.
- 3 Then, click **Display Ref** again to enable/disable the reference waveform display.

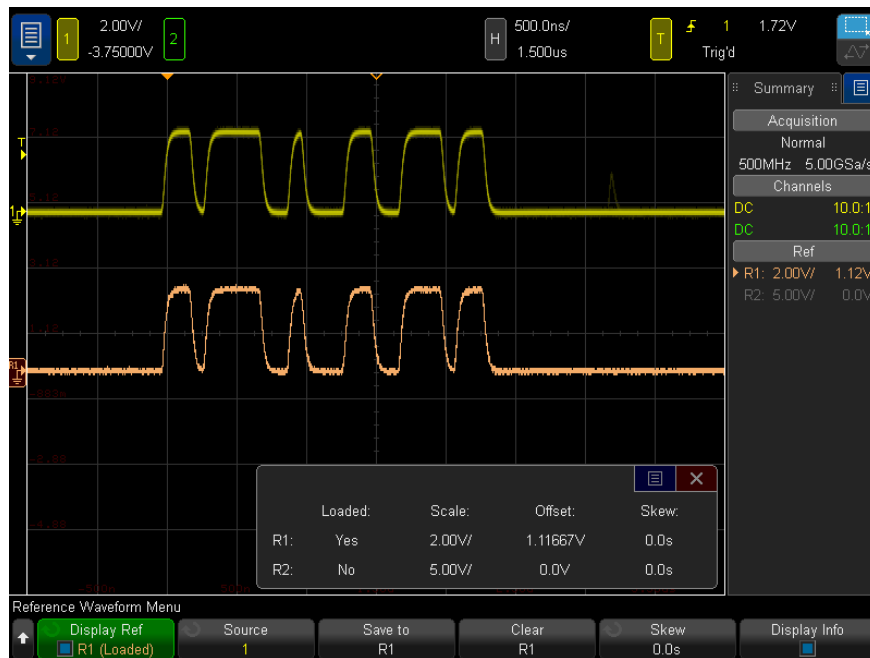

One reference waveform can be displayed at a time.

Reference waveforms are always drawn as vectors (that is, lines between waveform data points) and may look different than waveforms drawn as dots (if that option is available in your oscilloscope).

See Also · ["To display reference waveform information"](#) on page 100

## To display reference waveform information

- 1 Choose **Main Menu > Sources > Reference Waveforms** to turn on reference waveforms.
- 2 In the Reference Waveform Menu, click **Display Info** to enable (or disable) reference waveform information on the oscilloscope display.

## To scale and position reference waveforms

- 1 Display the reference waveform information (see **"To display reference waveform information"** on page 100).
- 2 Click the scale value to adjust the reference waveform scale.
- 3 Click the offset value to adjust the reference waveform position.

You can also click the skew value to adjust it.

## To adjust reference waveform skew

Once reference waveforms are displayed, you can adjust their skew.

- 1 Display the desired reference waveform (see "**To display a reference waveform**" on page 99).
- 2 Click **Skew** and enter the reference waveform skew.

## To save/recall reference waveform files

Analog channel, math, or reference waveforms can be saved to a reference waveform file. See **"To save reference waveform files"** on page 286.

You can recall a reference waveform file into one of the reference waveform locations. See **"To recall reference waveform files"** on page 291.





## 6 Serial Decode

Serial Decode Options / 106

Lister / 107

Searching Lister Data / 109

### Triggering on Serial Data

In some cases, such as when triggering on a slow serial signal (for example, I2C, SPI, CAN, LIN, etc.) it may be necessary to switch from the Auto trigger mode to the Normal trigger mode to prevent the oscilloscope from Auto-triggering and stabilize the display. You can change the trigger mode by choosing **Main Menu > Trigger > Trigger Mode and Coupling Menu** and clicking the **Mode** softkey button or by simply clicking the Run/Stop status in the upper-right corner of the display.

Also, the threshold voltage level must be set appropriately for each source channel. The threshold level for each serial signal can be set in the Signals Menu. Choose **Main Menu > Analyze > Serial Decode**, then click the **Signals** softkey button.

## Serial Decode Options

Keysight's hardware-accelerated serial decode options can be installed when the oscilloscope is manufactured, or added later. The following serial decode licenses are available:

Serial Decode License	See:
P9240ATOA – you can decode CAN (Controller Area Network) and LIN (Local Interconnect Network) serial buses.	<ul style="list-style-type: none"> <li>▪ <a href="#">"CAN/CAN FD Serial Decode"</a> on page 329.</li> <li>▪ <a href="#">"LIN Serial Decode"</a> on page 339.</li> </ul>
P9240CXPA – you can decode CXPI (Clock Extension Peripheral Interface) serial buses.	<ul style="list-style-type: none"> <li>▪ <a href="#">"CXPI Serial Decode"</a> on page 348.</li> </ul>
P9240EMBA – you can decode I2C (Inter-IC) serial buses.	<ul style="list-style-type: none"> <li>▪ <a href="#">"I2C Serial Decode"</a> on page 358.</li> </ul>
P9240CMPA – you can decode many UART (Universal Asynchronous Receiver/Transmitter) protocols including RS232 (Recommended Standard 232).	<ul style="list-style-type: none"> <li>▪ <a href="#">"UART/RS232 Serial Decode"</a> on page 414.</li> </ul>
P9240NRZA – you can decode Manchester and NRZ serial buses.	<ul style="list-style-type: none"> <li>▪ <a href="#">"Manchester Serial Decode"</a> on page 369.</li> <li>▪ <a href="#">"NRZ Serial Decode"</a> on page 377.</li> </ul>
P9240AROA – you can decode MIL-STD-1553 and ARINC 429 serial buses.	<ul style="list-style-type: none"> <li>▪ <a href="#">"MIL-STD-1553 Serial Decode"</a> on page 384.</li> <li>▪ <a href="#">"ARINC 429 Serial Decode"</a> on page 392.</li> </ul>
P9240SNSA – you can decode SENT (Single Edge Nibble Transmission) serial buses.	<ul style="list-style-type: none"> <li>▪ <a href="#">"SENT Serial Decode"</a> on page 404.</li> </ul>
P9240UPDA – you can decode USB PD (Power Delivery) serial buses.	<ul style="list-style-type: none"> <li>▪ <a href="#">"USB PD Serial Decode"</a> on page 423.</li> </ul>

To determine whether these licenses are installed on your oscilloscope, see ["To display oscilloscope information"](#) on page 302.

To order serial decode licenses, go to [www.keysight.com](http://www.keysight.com) and search for the product number (for example, P9240ATOA) or contact your local Keysight Technologies representative (see [www.keysight.com/find/contactus](http://www.keysight.com/find/contactus)).

## Lister

Lister is a powerful tool for investigating protocol failures. You can use Lister to view large amounts of packet-level serial data in a tabular format, including time tags and specific decoded values. When acquisitions are stopped, you can select a line in the Lister window and click the **Zoom to Selection** softkey label button to jump to the event.

To use the Lister:

- 1 Choose **Main Menu > Analyze > Serial Decode** and set up decode on the serial data signals to be analyzed.
- 2 Click **Lister**.
- 3 Click **Window**; then, select the size of the Lister window (**Half-Screen** or **Full-Screen**).

You can click the Lister down or up chevrons at the top right of the graticule to select the size of the Lister window.

- 4 Click **Display**; then, select **Serial 1** or **Serial 2** on which the serial bus signals are being decoded. (If you select **All**, the decode information for different buses is interleaved in time.)

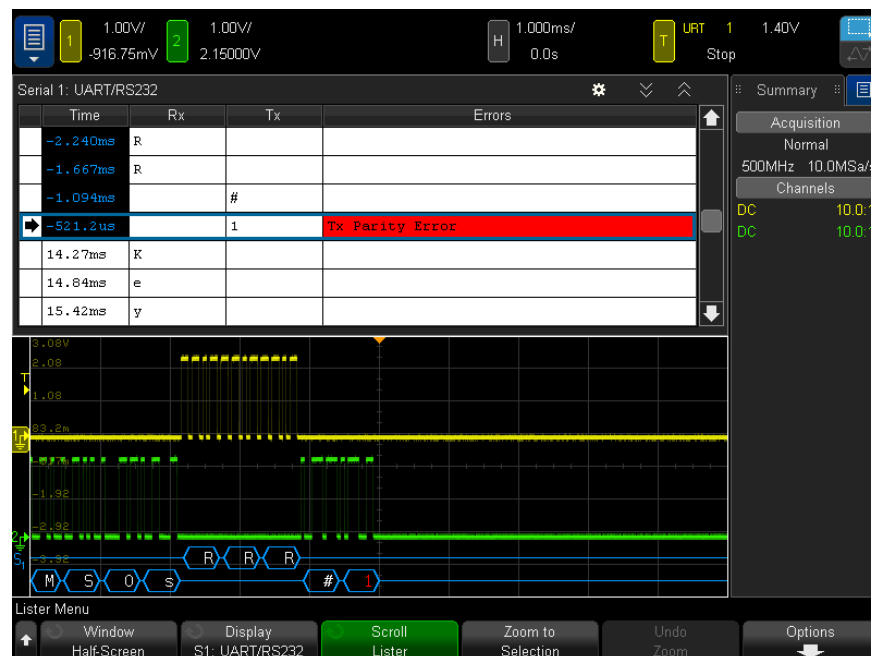

Before you can select a row or navigate through the Lister data, oscilloscope acquisitions must be stopped.

- 5 Choose **Main Menu > Single** to stop acquisitions.

A single acquisition instead of stopping running acquisitions fills the maximum memory depth.

When zoomed out and viewing a large number of packets, the Lister may not be able to display information for all packets. However, when you perform a single acquisition, the Lister will contain all on-screen serial decode information.

- 6 Use the scroll bar in the Lister window to scroll through the data.

Time tags in the Time column indicate the event time relative to the trigger point by default, and can optionally be configured to be relative to the previous row, as described in step 9 that follows. The time tags of events that are shown in the waveform display area are displayed with a dark background.

- 7 Click **Zoom to Selection** to center the waveform display at the time associated with the selected Lister row and automatically set the horizontal scale setting.
- 8 Click **Undo Zoom** to return to the horizontal scale and delay settings before the last **Zoom to Selection**.
- 9 Click **Options** to open the Lister Options Menu. In this menu, you can:
  - Enable or disable the **Track Time** option. When enabled, as you select different Lister rows (when acquisitions are stopped), the horizontal delay changes to the Time of the selected row. Also, changing the horizontal delay will scroll the Lister.
  - Click **Time Ref** to select whether the Time column in the Lister display shows times relative to the trigger or relative to the previous packet row.

## Searching Lister Data

To find and place marks on rows in the Lister (when serial decode and Lister are enabled):

- 1 Choose **Main Menu > Analyze > Waveform Search**.
- 2 Click the **Search** softkey button, and select **Serial 1** or **Serial 2**.
- 3 Use the **Search for** softkey to specify events to find. It is similar to specifying protocol triggers.

Events that are found are marked in orange in the far left Lister column. The total number of events found is displayed above the softkeys.

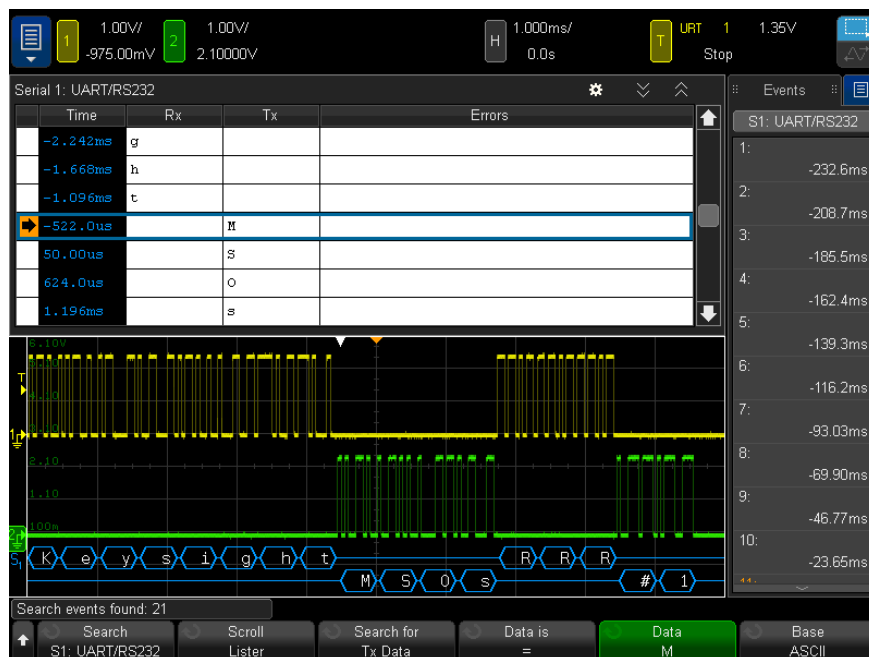

Each serial decode option lets you find protocol-specific headers, data, errors, etc. See:

- ["Searching for ARINC 429 Data in the Lister"](#) on page 395
- ["Searching for CAN Data in the Lister"](#) on page 333
- ["Searching for I2C Data in the Lister"](#) on page 360
- ["Searching for LIN Data in the Lister"](#) on page 341
- ["Searching for MIL-STD-1553 Data in the Lister"](#) on page 387
- ["Searching for SENT Data in the Lister"](#) on page 408
- ["Searching for UART/RS232 Data in the Lister"](#) on page 417



# 7 Display Settings

- To adjust waveform intensity / 112
- To set or clear persistence / 114
- To clear the display / 116
- To select the grid type / 117
- To adjust the grid intensity / 118
- To add an annotation / 119
- To disable/enable antialiasing / 121
- To freeze the display / 122

## To adjust waveform intensity

You can adjust the intensity of displayed waveforms to account for various signal characteristics, such as fast time/div settings and low trigger rates.

Increasing the intensity lets you see the maximum amount of noise and infrequently occurring events.

Reducing the intensity can expose more detail in complex signals as shown in the following figures.

- 1 Choose **Main Menu > Setup > Waveform Intensity**.
- 2 In the dialog box that appears, drag the Waveform Intensity slider.

Waveform intensity adjustment affects analog channel waveforms only (not math waveforms, reference waveforms, digital waveforms, etc.).

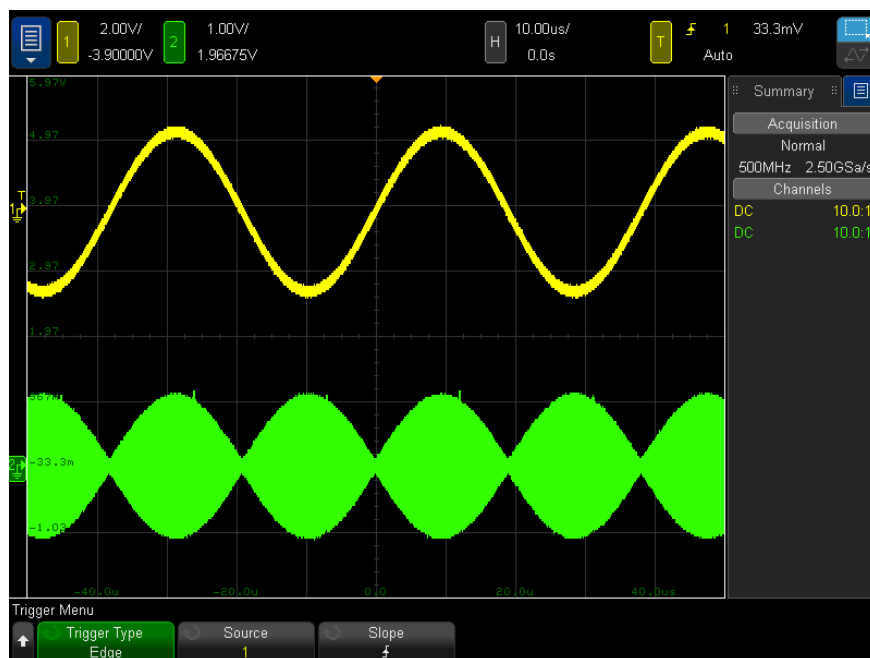

**Figure 18** Amplitude Modulation Shown at 100% Intensity



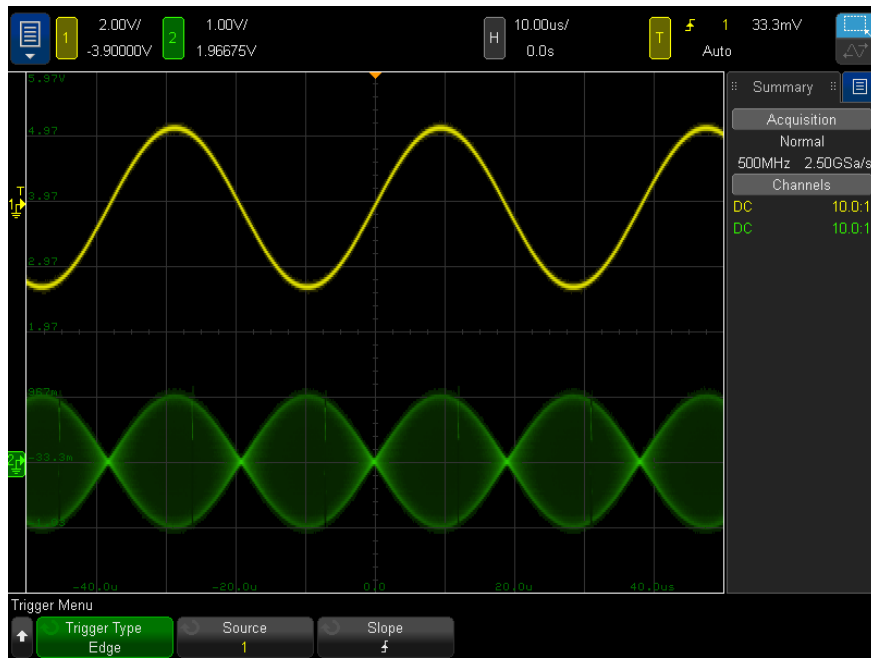

**Figure 19** Amplitude Modulation Shown at 40% Intensity

## To set or clear persistence

With persistence, the oscilloscope updates the display with new acquisitions, but does not immediately erase the results of previous acquisitions. All previous acquisitions are displayed with reduced intensity. New acquisitions are shown in their normal color with normal intensity.

Waveform persistence is kept only for the current display area; you cannot pan and zoom the persistence display.

To use persistence:

- 1 Choose **Main Menu > Setup > Display Menu**.



- 2 Click **Persistence**; then, select between:

- **Off** – turns off persistence.

When persistence is off, you can click the **Capture Waveforms** softkey to perform a single-shot infinite persistence. A single acquisition's data is displayed with reduced intensity, and it remains on the display until you clear persistence or clear the display.

- **∞ Persistence** – (infinite persistence) Results of previous acquisitions are never erased.

Use infinite persistence to measure noise and jitter, to see the worst-case extremes of varying waveforms, to look for timing violations, or to capture events that occur infrequently.

- **Variable Persistence** – Results of previous acquisitions are erased after a certain amount of time.

Variable persistence gives you a view of acquired data that is similar to analog oscilloscopes.

When variable persistence is selected, click the **Time** softkey and specify the amount of time that previous acquisitions are to be displayed.

- **Adaptive Persistence** – All previous acquisitions that have taken place in hardware since the last controller PC screen capture are displayed.

This is the default setting. Adaptive persistence mode should be used to see infrequent glitches on the graticule.

The display will begin accumulating multiple acquisitions.

- 3 To erase the results of previous acquisitions from the display, click **Clear Persistence**.

The oscilloscope will start to accumulate acquisitions again.

- 4 To return the oscilloscope to the normal display mode, turn off persistence; then, click **Clear Persistence**.

Turning off persistence does not clear the display. The display is cleared if you click the **Clear Display** softkey or if you choose **Main Menu > Autoscale** (which also turns off persistence).

For another method of seeing worst-case extremes of varying waveforms, see "**Glitch or Narrow Pulse Capture**" on page 185.

## To clear the display

- 1 Choose **Main Menu > Setup > Display Menu**.
- 2 Click **Clear Display**.

You can also configure the **Main Menu > Quick Action** menu item to clear the display. See "[Configuring the Quick Action Menu Item](#)" on page 304.

## To select the grid type

When the **Video** trigger type is selected (see "**Video Trigger**" on page 154), and the vertical scaling of at least one displayed channel is 140 mV/div, the **Grid** softkey lets you select from these grid types:

- **Full** – the normal oscilloscope grid.
- **mV** – shows vertical grids, labeled on the left, from -0.3 V to 0.8 V.
- **IRE** – (Institute of Radio Engineers) shows vertical grids in IRE units, labeled on the left, from -40 to 100 IRE. The 0.35 V and 0.7 V levels from the **mV** grid are also shown and labeled at the right. When the **IRE** grid is selected, cursor values are also shown in IRE units. (Cursor values via the remote interface are not in IRE units.)

The **mV** and **IRE** grid values are accurate (and match Y cursor values) when the vertical scaling is 140 mV/division and the vertical offset is 245 mV.

To select the grid type:

- 1 Choose **Main Menu > Setup > Display Menu**.
- 2 Click **Grid**.
- 3 In the Grid Menu, click **Grid** softkey; then, select the grid type.

## To adjust the grid intensity

To adjust the display grid (graticule) intensity:

- 1 Choose **Main Menu > Setup > Display Menu**.
- 2 Click **Grid**.
- 3 In the Grid Menu, click **Grid Intensity**; then, enter the intensity of the displayed grid.

The intensity level is shown in the **Intensity** softkey and is adjustable from 0 to 100%.

Each major vertical division in the grid corresponds to the vertical sensitivity shown in the status line at the top of the display.

Each major horizontal division in the grid corresponds to the time/div shown in the status line at the top of the display.

## To add an annotation

You can add annotations to the oscilloscope's display. Annotations are useful for documentation purposes, to add notes before capturing screens.

To add an annotation:

- 1 Choose **Main Menu > Setup > Display Menu**.
- 2 Click **Annotations**.
- 3 In the Annotations Menu, click the **Display** softkey button and select the desired annotation.
- 4 Then, click the **Display** softkey again to enable/disable the annotation display.

When enabled, you can drag the annotation anywhere in the graticule, or use the **X1** and **Y1** softkeys.

- 5 Click **Edit**.
- 6 In the Edit keypad dialog box, enter the annotation text.

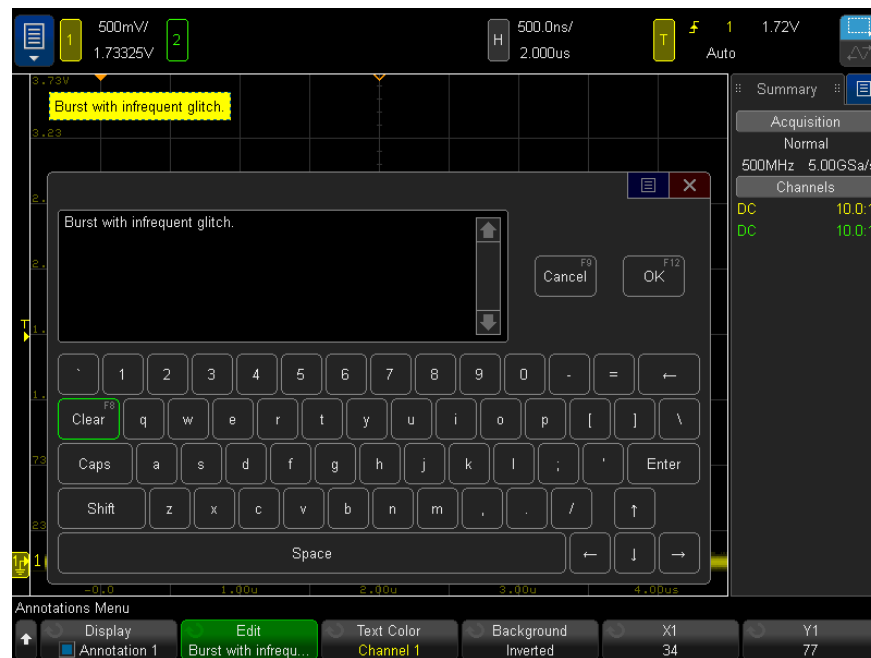

- 7 When you are done entering text, select the dialog box's Enter or OK key or click the **Edit** softkey again.

The annotation text appears in the softkey.

- 8 Click **Text Color** to select the annotation color.

You can choose white, red, or colors that match analog channels, digital channels, math waveforms, reference waveforms, or markers.

9 Click **Background** and select the annotation background:

- **Opaque** – the annotation has a solid background.
- **Inverted** – the annotation's foreground and background colors are switched.

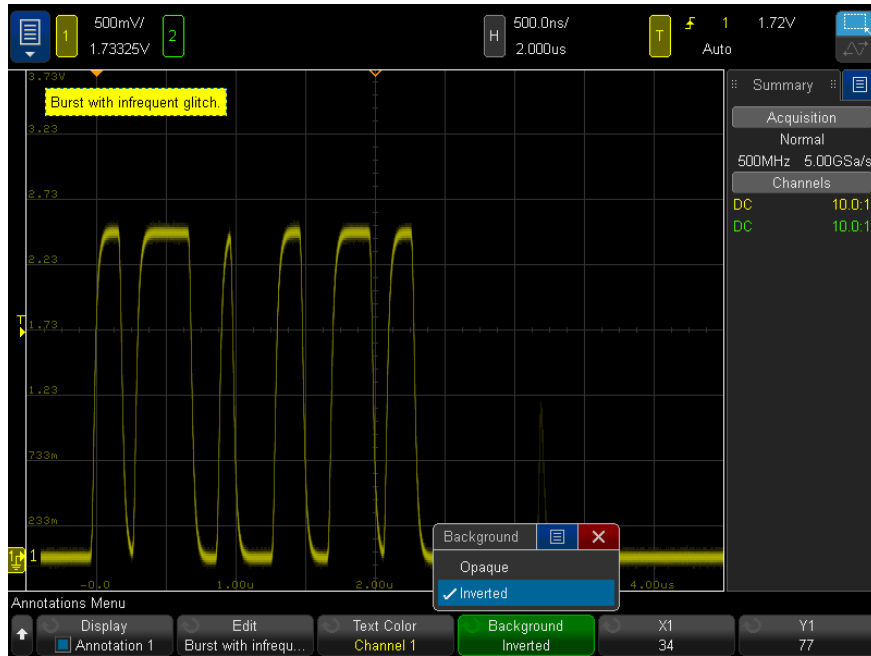

See Also · ["To save BMP or PNG image files"](#) on page 283



## To disable/enable antialiasing

At slower sweep speeds, the sample rate is reduced and a proprietary display algorithm is used to minimize the likelihood of aliasing.

By default, Antialiasing is enabled. You should leave Antialiasing enabled unless there is a specific reason to switch it off.

Anti-aliasing is turned off automatically, even though the **Antialiasing** softkey appears to be enabled, when FFTs are on or when the Envelope or Differentiate math functions are on.

If you need to switch Antialiasing off, choose **Main Menu > Setup > Display Menu** and click the **Antialiasing** softkey button to switch the feature off. The displayed waveforms will be more susceptible to aliasing.

## To freeze the display

To freeze the display without stopping running acquisitions, you must configure the **Main Menu > Quick Action** menu item. See "[Configuring the Quick Action Menu Item](#)" on page 304.

- 1 Once the **Main Menu > Quick Action** menu item has been configured with the **Quick Freeze Display** action, choose this menu item to freeze the display.
- 2 To un-freeze the display, choose **Main Menu > Quick Action** again.

Manual cursors can be used on the frozen display.

Many activities, such as adjusting the trigger level, adjusting vertical or horizontal settings, or saving data will un-freeze the display.

## 8 Labels

To turn the label display on or off / 124

To assign a predefined label to a channel / 125

To define a new label / 126

To load a list of labels from a text file you create / 127

To reset the label library to the factory default / 128

You can define labels and assign them to each analog input channel, or you can turn labels off to increase the waveform display area.

To turn the label display on or off

- 1 Choose **Main Menu > Setup > Channel Labels**.
- 2 Click the **Display Labels** softkey button to turn the label display on.

This turns on labels for the displayed waveforms. Labels are displayed at the left edge of the displayed traces.

The figure below shows an example of displayed labels.

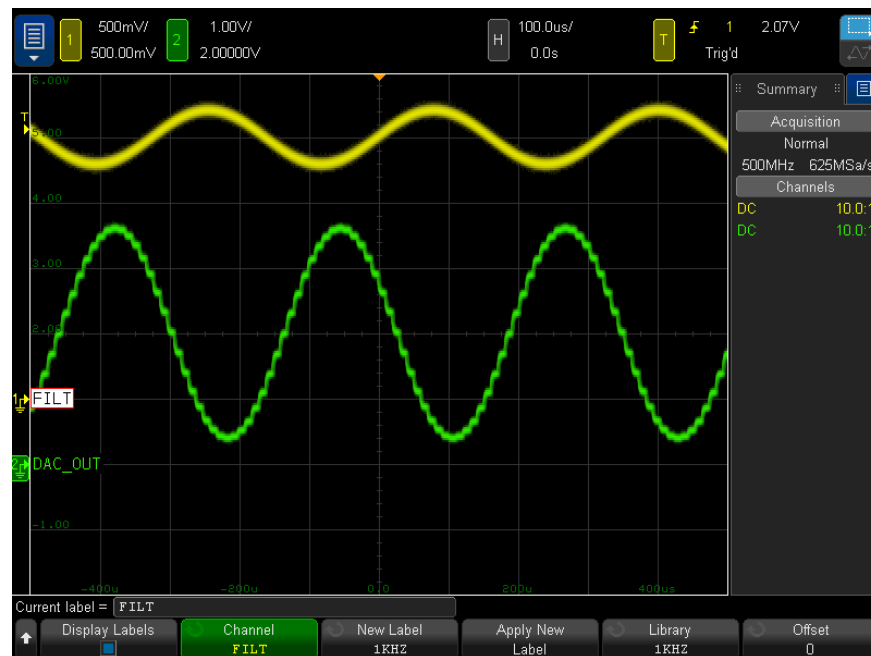

- 3 To turn the labels off, click **Display Labels** again.

To assign a predefined label to a channel

- 1 Choose **Main Menu > Setup > Channel Labels**.
- 2 Click the **Channel** softkey button, then select a channel for label assignment.

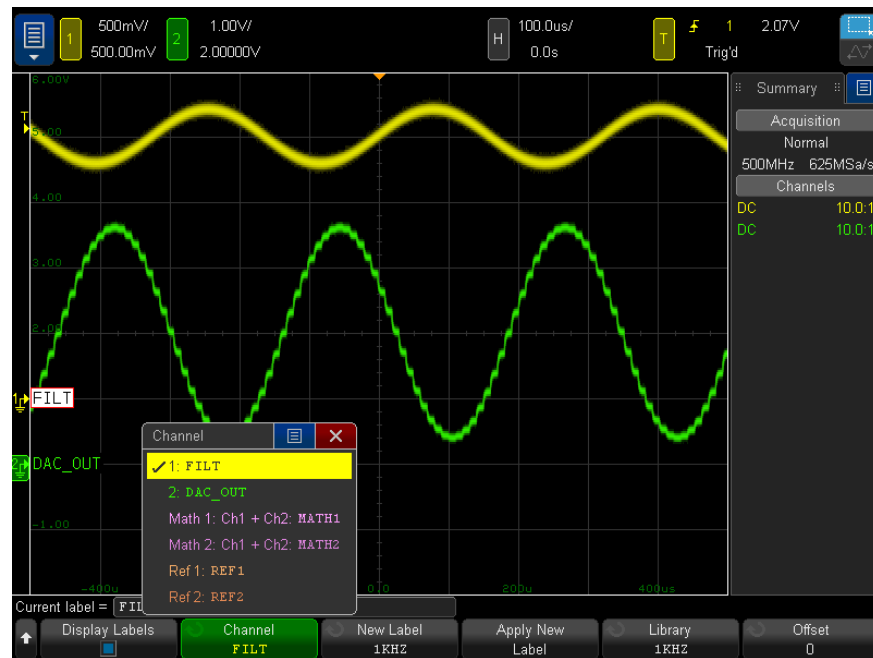

The figure above shows the list of channels and their default labels. The channel does not have to be turned on to have a label assigned to it.

- 3 Click **Library**, then select a predefined label from the library.
- 4 Click **Apply New Label** to assign the label to your selected channel.
- 5 Repeat the above procedure for each predefined label you want to assign to a channel.

## To define a new label

- 1 Choose **Main Menu > Setup > Channel Labels**.
- 2 Click the **Channel** softkey button; then, select a channel for label assignment.  
The channel does not have to be turned on to have a label assigned to it. If the channel is turned on, its current label will be highlighted.
- 3 Click the **New Label** softkey button.
- 4 In the New Label keypad dialog, enter the label text.
- 5 When you are done entering text, select the dialog box's Enter or OK key or click the **New Label** softkey again.  
The new label appears in the softkey.
- 6 Click **Apply New Label** to assign the label to your selected channel and to save the new label to the Library.

When you define a new label, it is added to the non-volatile label list.

### Label Assignment Auto-Increment

When you assign a label ending in a digit, such as ADDR0 or DATA0, the oscilloscope automatically increments the digit and displays the modified label in the "New label" field after you click **Apply New Label**. Therefore, you only need to select a new channel and click **Apply New Label** again to assign the label to the channel. Only the original label is saved in the label list. This feature makes it easier to assign successive labels to numbered control lines and data bus lines.

## To load a list of labels from a text file you create

It may be convenient to create a list of labels using a text editor, then load the label list into the oscilloscope. The list can have up to 75 labels. When loaded, labels are added to the beginning of the oscilloscope's list. If more than 75 labels are loaded, only the first 75 are stored.

To load labels from a text file into the oscilloscope:

- 1 Use a text editor to create each label. Each label can be up to 32 characters in length. Separate each label with a line feed.
- 2 Name the file `labellist.txt` and save it on the chassis controller PC.
- 3 Load the list into the oscilloscope using the File Explorer (choose **Main Menu > Utilities > File Explorer Menu**).

### NOTE

#### Label List Management

When you click the **Library** softkey button, you will see a list of the last 75 labels used. The list does not save duplicate labels. Labels can end in any number of trailing digits. As long as the base string is the same as an existing label in the library, the new label will not be put in the library. For example, if label `A0` is in the library and you make a new label called `A12345`, the new label is not added to the library.

When you save a new user-defined label, the new label will replace the oldest label in the list. Oldest is defined as the longest time since the label was last assigned to a channel. Any time you assign any label to a channel, that label will move to the newest in the list. Thus, after you use the label list for a while, your labels will predominate, making it easier to customize the instrument display for your needs.

When you reset the label library list (see next topic), all of your custom labels will be deleted, and the label list will be returned to its factory configuration.

---

## To reset the label library to the factory default

**NOTE**

Clicking the **Reset Library** softkey will remove all user-defined labels from the library and set the labels back to the factory default. Once deleted, these user-defined labels cannot be recovered.

---

- 1 Choose **Main Menu > Utilities > User Options Menu**.
- 2 In the User Options Menu, click **Preferences**.
- 3 In the User Preferences Menu, click **Reset Library**.

This will delete all user-defined labels from the library and set the labels in the library back to the factory default. However, this does not default the labels currently assigned to the channels (those labels that appear in the waveform area).

**NOTE****Defaulting labels without erasing the default library**

Choosing **Main Menu > Default Setup** sets all channel labels back to the default labels but does not erase the list of user-defined labels in the library.

---



# 9 Triggers

- Adjusting the Trigger Level / 131
- Forcing a Trigger / 132
- Edge Trigger / 133
- Edge then Edge Trigger / 135
- Pulse Width Trigger / 137
- Pattern Trigger / 139
- OR Trigger / 142
- Rise/Fall Time Trigger / 144
- Near Field Communication (NFC) Trigger / 146
- Nth Edge Burst Trigger / 149
- Runt Trigger / 150
- Setup and Hold Trigger / 152
- Video Trigger / 154
- Serial Trigger / 166
- Zone Qualified Trigger / 167

A trigger setup tells the oscilloscope when to acquire and display data. For example, you can set up to trigger on the rising edge of the analog channel 1 input signal.

You can adjust the vertical level used for analog channel edge detection by clicking the level value in the upper-right corner of the display.

In addition to the edge trigger type, you can also set up triggers on rise/fall times, Nth edge bursts, patterns, pulse widths, runt pulses, setup and hold violations, TV signals, and serial signals (if option licenses are installed).

You can use any input channel or the Ext Trig input (see "[External Trigger Input](#)" on page 176) as the source for most trigger types.

Changes to the trigger setup are applied immediately. If the oscilloscope is stopped when you change a trigger setup, the oscilloscope uses the new specification when you start making acquisitions again. If the oscilloscope is running when you change a trigger setup, it uses the new trigger definition when it starts the next acquisition.

To acquire and display data when triggers are not occurring, you can choose **Main Menu > Trigger > Force Trigger**.

You can choose **Main Menu > Trigger > Trigger Mode and Coupling Menu** to set options that affect all trigger types (see [Chapter 10](#), “Trigger Mode/Coupling,” starting on page 169).

You can save trigger setups along with the oscilloscope setup (see [Chapter 18](#), “Save/Email/Recall (Setups, Screens, Data),” starting on page 281).

#### Triggers - General Information

A triggered waveform is one in which the oscilloscope begins tracing (displaying) the waveform, from the left side of the display to the right, each time a particular trigger condition is met. This provides stable display of periodic signals such as sine waves and square waves, as well as nonperiodic signals such as serial data streams.

The figure below shows the conceptual representation of acquisition memory. You can think of the trigger event as dividing acquisition memory into a pre-trigger and post-trigger buffer. The position of the trigger event in acquisition memory is defined by the time reference point and the delay (horizontal position) setting (see ["To adjust the horizontal delay \(position\)"](#) on page 38).

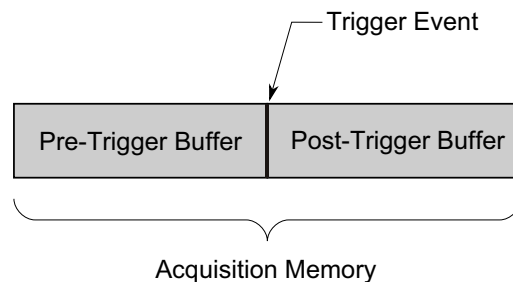

## Adjusting the Trigger Level

The value of the analog channel trigger level is displayed in the upper-right corner of the display.

You can adjust the trigger level by clicking the level value. See "[Access the Trigger Menu, Change the Trigger Mode, and Open the Trigger Level Dialog Box](#)" on page 32.

The position of the trigger level for the analog channel is indicated by the trigger level icon  (if the analog channel is on) at the far left side of the display. You can adjust the trigger level by dragging the icon vertically.

### NOTE

You can also change the trigger level of all channels by choosing **Main Menu > Analyze > Analyze Menu**, clicking **Features**, and then selecting **Trigger Levels**.

---

## Forcing a Trigger

Choosing **Main Menu > Trigger > Force Trigger** causes a trigger (on anything) and displays the acquisition.

This is useful in the Normal trigger mode where acquisitions are made only when the trigger condition is met. In this mode, if no triggers are occurring (that is, the "Trig'd?" indicator is displayed), you can choose **Main Menu > Trigger > Force Trigger** to force a trigger and see what the input signals look like.

In the Auto trigger mode, when the trigger condition is not met, triggers are forced and the "Auto?" indicator is displayed.

## Edge Trigger

The Edge trigger type identifies a trigger by looking for a specified edge (slope) and voltage level on a waveform. You can define the trigger source and slope in this menu. The trigger type, source, and level are displayed in the upper-right corner of the display.

- 1 Choose **Main Menu > Trigger > Trigger Menu**.
- 2 In the Trigger Menu, click the **Trigger Type** softkey button, and select **Edge**.
- 3 Select the trigger source:
  - Analog channel, **1** to the number of channels
  - **External** – triggers on the Ext Trig signal.
  - **WaveGen** – triggers at the 50% level of the rising edge of the waveform generator output signal. (Not available when the DC, Noise, or Cardiac waveforms are selected.)
  - **WaveGen Mod (FSK/FM)** – when waveform generator FSK or FM modulation is used, triggers at the 50% level of the rising edge of the modulating signal.

You can choose a channel that is turned off (not displayed) as the source for the edge trigger.

The selected trigger source is indicated in the upper-right corner of the display next to the slope symbol:

- **1** or **2** = analog channels.
  - **E** = External trigger input.
  - **W** = Waveform generator.
- 4 Click the **Slope** softkey and select:
    - **Rising** edge.
    - **Falling** edge.
    - **Alternating** edges – Useful when you want to trigger on both edges of a clock (for example, DDR signals).
    - **Either** edge – Useful when you want to trigger on any activity of a selected source.

Rising and Falling edge modes operate up to the bandwidth of the oscilloscope. Other modes operate up to the bandwidth of the oscilloscope or 1 GHz, whichever is smaller.

The selected slope is displayed in the upper-right corner of the display.

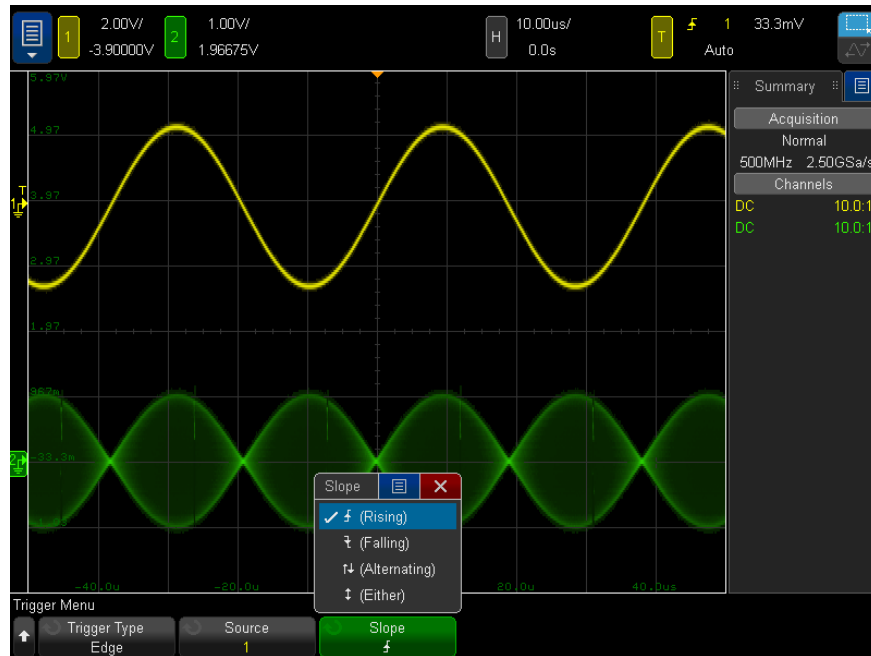

### Using Autoscale to Set Up Edge Triggers

The easiest way to set up an Edge trigger on a waveform is to use Autoscale. Simply choose **Main Menu > Autoscale** and the oscilloscope will attempt to trigger on the waveform using a simple Edge trigger type.

#### NOTE

### MegaZoom Technology Simplifies Triggering

With the built-in MegaZoom technology, you can simply Autoscale the waveforms, then stop the oscilloscope to capture a waveform. You can then pan and zoom through the data by adjusting the horizontal and vertical scale to find a stable trigger point. Autoscale often produces a triggered display.

## Edge then Edge Trigger

The Edge then Edge trigger mode triggers when the Nth edge occurs after an arming edge and a delay period.

The arm and trigger edges can be specified as  $\uparrow$  (Rising) or  $\downarrow$  (Falling) edges on analog channels.

- 1 Choose **Main Menu > Trigger > Trigger Menu**.
- 2 In the Trigger Menu, click the **Trigger Type** softkey button, and select **Edge then Edge**.



- 3 Click the **Sources** softkey.
- 4 In the Edge Then Edge Sources Menu:



- a Click the **Arm A** softkey, and select the channel on which the arming edge will occur.
- b Click the **Slope A** softkey to specify which edge of the Arm A signal will arm the oscilloscope.
- c Click the **Trigger B** softkey, and select the channel on which the trigger edge will occur.
- d Click the **Slope B** softkey to specify which edge of the Trigger B signal will trigger the oscilloscope.

The value of the trigger level is displayed in the upper-right corner of the display.

Adjust the trigger level for the selected analog channel by clicking the level value.

- 5 Click the  Back/Up softkey to return to the Trigger Menu.
- 6 Click the **Delay** softkey; then, enter the delay time between the Arm A edge and the Trigger B edge.
- 7 Click the **Nth Edge B** softkey; then, enter the Nth edge of the Trigger B signal to trigger on.



## Pulse Width Trigger

Pulse Width (glitch) triggering sets the oscilloscope to trigger on a positive or negative pulse of a specified width. If you want to trigger on a specific timeout value, use **Pattern** trigger in the Trigger Menu (see "**Pattern Trigger**" on page 139).

- 1 Choose **Main Menu > Trigger > Trigger Menu**.
- 2 In the Trigger Menu, click the **Trigger Type** softkey button, and select **Pulse Width**.

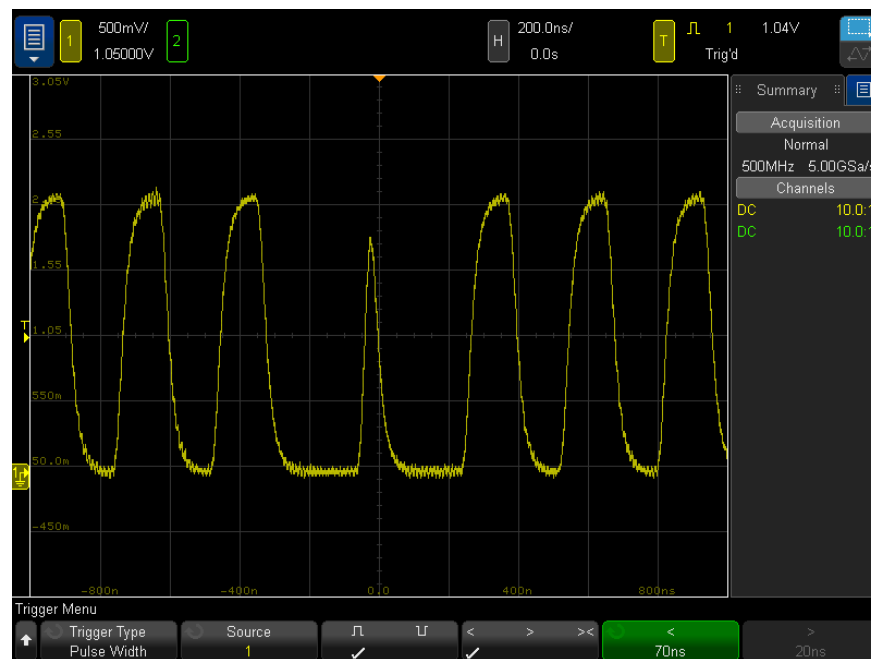

- 3 Click the **Source** softkey; then, select a channel source for the trigger.  
The channel you select is shown in the upper-right corner of the display next to the polarity symbol.  
The source can be any analog channel available on your oscilloscope.
- 4 Adjust the trigger level.  
The value of the trigger level is displayed in the upper-right corner of the display.  
You can adjust the trigger level by clicking the level value.
- 5 Click the pulse polarity softkey to select positive ( $\sqcup$ ) or negative ( $\sqcap$ ) polarity for the pulse width you want to capture.  
The selected pulse polarity is displayed in the upper-right corner of the display. A positive pulse is higher than the current trigger level or threshold and a negative pulse is lower than the current trigger level or threshold.

When triggering on a positive pulse, the trigger will occur on the high to low transition of the pulse if the qualifying condition is true. When triggering on a negative pulse, the trigger will occur on the low to high transition of the pulse if the qualifying condition is true.

**6** Click the qualifier softkey (< > ><) to select the time qualifier.

The Qualifier softkey can set the oscilloscope to trigger on a pulse width that is:

- Less than a time value (<).

For example, for a positive pulse, if you set  $t < 10$  ns:



- Greater than a time value (>).

For example, for a positive pulse, if you set  $t > 10$  ns:



- Within a range of time values (><).

For example, for a positive pulse, if you set  $t > 10$  ns and  $t < 15$  ns:

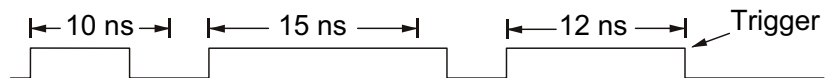

**7** Click the qualifier time set softkey (< or >), then enter the pulse width qualifier time.

The qualifiers can be set as follows:

- 2 ns to 10 s for > or < qualifier (6 ns to 10 s for the 200 MHz and bandwidth model).
- 10 ns to 10 s for >< qualifier, with minimum difference of 5 ns between upper and lower settings.

**Pulse width trigger < qualifier time set softkey**

- When the less than (<) qualifier is selected, the oscilloscope triggers on a pulse width less than the time value displayed on the softkey.
- When the time range (><) qualifier is selected, use this softkey to set the upper time range value.

**Pulse width trigger > qualifier time set softkey**

- When the greater than (>) qualifier is selected, the oscilloscope triggers on a pulse width greater than the time value displayed on the softkey.
- When the time range (><) qualifier is selected, use this softkey to set the lower time range value.

## Pattern Trigger

The Pattern trigger identifies a trigger condition by looking for a specified pattern. This pattern is a logical AND combination of the channels. Each channel can have a value of 0 (low), 1 (high), or don't care (X). A rising or falling edge can be specified for one channel included in the pattern.



- 1 Choose **Main Menu > Trigger > Trigger Menu**.
- 2 In the Trigger Menu, click the **Trigger Type** softkey button, and select **Pattern**.
- 3 Click the **Qualifier** softkey; then, select from the pattern duration qualifier options:
  - **Entered** – when the pattern is entered.
  - **<** (Less Than) – when the pattern is present for less than a time value.
  - **>** (Greater Than) – when the pattern is present for greater than a time value. The trigger occurs when the pattern exits (not when the > softkey time value is exceeded).
  - **Timeout** – when the pattern is present for greater than a time value. In this case, the trigger occurs when the > softkey time value is exceeded (not when the pattern exits).
  - **>< (In Range)** – when the pattern is present for a time within a range of values.
  - **<> (Out of Range)** – when the pattern is present for a time outside of range of values.

Pattern durations are evaluated using a timer. The timer starts on the last edge that makes the pattern (logical AND) true. Except when the **Timeout** qualifier is selected, the trigger occurs on the first edge that makes the pattern false, provided the time qualifier criteria has been met.

The time values for the selected qualifier are set using the qualifier time set softkeys (< and >).

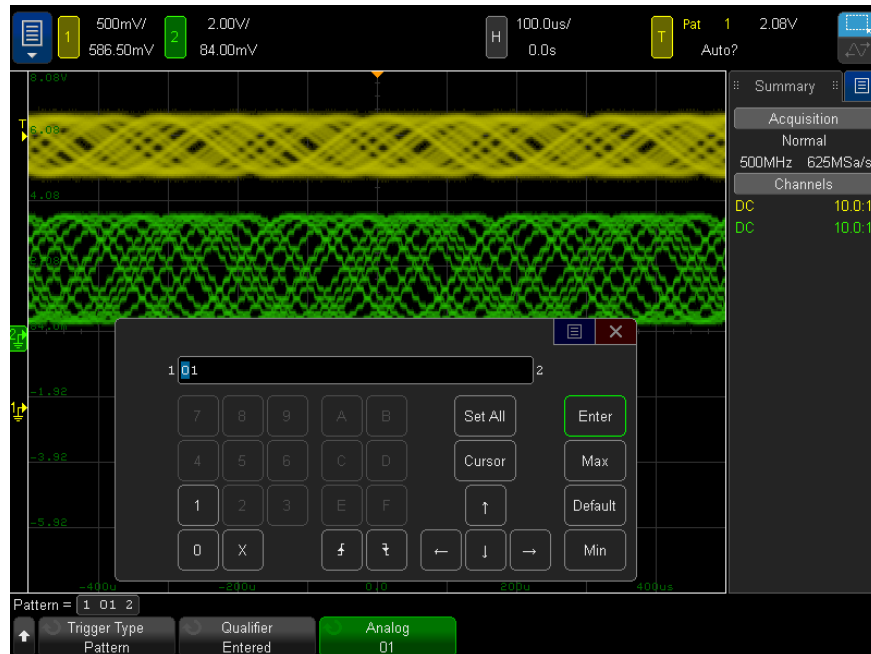
- 4 To set the analog channel patterns, click the **Analog** softkey and use the binary keypad dialog to enter:



- **0** sets the pattern to zero (low) on the selected channel. A low is a voltage level that is less than the channel's trigger level or threshold level.
- **1** sets the pattern to 1 (high) on the selected channel. A high is a voltage level that is greater than the channel's trigger level or threshold level.
- **X** sets the pattern to don't care on the selected channel. Any channel set to don't care is ignored and is not used as part of the pattern. However, if all channels in the pattern are set to don't care, the oscilloscope will not trigger.
- The rising edge () or falling edge () softkey sets the pattern to an edge on the selected channel. Only one rising or falling edge can be specified in the pattern. When an edge is specified, the oscilloscope will trigger at the edge specified if the pattern set for the other channels is true.

If no edge is specified, the oscilloscope will trigger on the last edge that makes the pattern true.

#### NOTE

#### Specifying an Edge in a Pattern

You are allowed to specify only one rising or falling edge term in the pattern. If you define an edge term, then select a different channel in the pattern and define another edge term, the previous edge definition is changed to a don't care.

The specified pattern is shown in the "Pattern =" line directly above the softkeys.

- 5 Adjust the trigger levels for analog channels: choose **Main Menu > Analyze > Analyze Menu**, click **Features**, and then select **Trigger Levels**.

## OR Trigger

The OR trigger mode triggers when any one (or more) of the specified edges on analog channels is found.

- 1 Choose **Main Menu > Trigger > Trigger Menu**.
- 2 In the Trigger Menu, click the **Trigger Type** softkey button, and select **OR**.
- 3 Click the **Slope** softkey and select rising edge, falling edge, either edge, or don't care.

The selected slope is displayed in the upper-right corner of the display.

- 4 For each analog channel you want to include in the OR trigger, click the **Channel** softkey to select the channel.

As you click the **Channel** softkey, the channel you select is highlighted in the OR = line directly above the softkeys and in the upper-right corner of the display next to the OR gate symbol.

The value of the trigger level is displayed in the upper-right corner of the display.

Adjust the trigger level for the selected analog channel by clicking the trigger level value.

- 5 For each channel you select, click the **Slope** softkey and select **f** (Rising), **F** (Falling), **↑** (Either), or **X** (Don't Care). The selected slope is displayed above the softkeys.

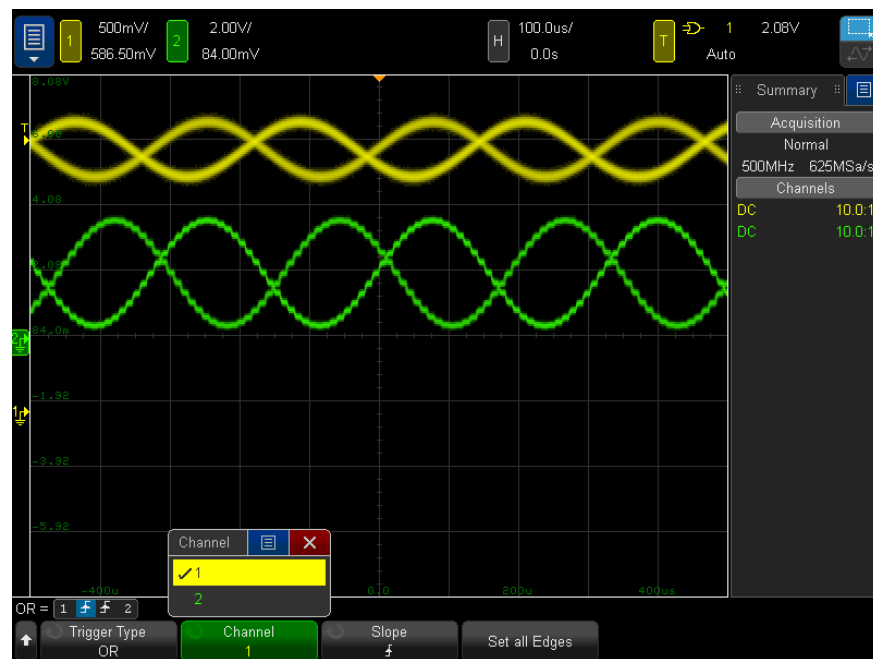

If all channels in the OR trigger are set to don't care, the oscilloscope will not trigger.

- 6 To set all analog channels to the edge selected by the **Slope** softkey, click the **Set all Edges** softkey.

## Rise/Fall Time Trigger

The Rise/Fall Time trigger looks for a rising or falling transition from one level to another level in greater than or less than a certain amount of time.

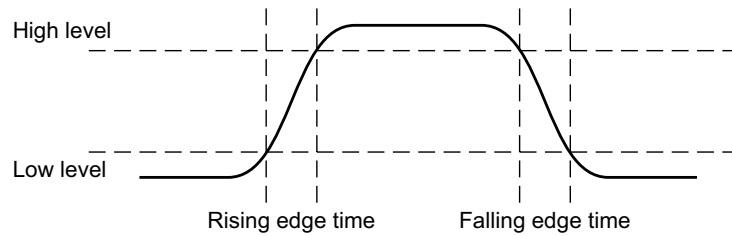

- 1 Choose **Main Menu > Trigger > Trigger Menu**.
- 2 In the Trigger Menu, click the **Trigger Type** softkey button, and select **Rise/Fall Time**.



- 3 Click the **Source** softkey, and select the input channel source.
- 4 Click the **Rising Edge or Falling Edge** softkey to toggle between edge types.
- 5 Click the **Level Select** softkey to select **High**; then, adjust the high level in the upper-right corner of the display.
- 6 Click the **Level Select** softkey to select **Low**; then, adjust the low level in the upper-right corner of the display.



- 7 Click the **Qualifier** softkey to toggle between "greater than" or "less than".
- 8 Click the **Time** softkey, and enter the time.

## Near Field Communication (NFC) Trigger

NFC (Near Field Communication) triggering is used to capture waveforms used in NFC testing.

The NFC trigger type is license-enabled.

**Table 2** NFC Triggering Characteristics

Standard:	Trigger on:	In "Arm & Trigger":	
		Arm on:	Trigger on:
NFC-A	<ul style="list-style-type: none"> <li>▪ SENS_REQ</li> <li>▪ ALL_REQ</li> <li>▪ Either (SENS_REQ or ALL_REQ)</li> <li>▪ SDD_REQ</li> <li>▪ Arm &amp; Trigger</li> </ul>	<ul style="list-style-type: none"> <li>▪ SENS_REQ</li> <li>▪ ALL_REQ</li> <li>▪ Either (SENS_REQ or ALL_REQ)</li> </ul>	<ul style="list-style-type: none"> <li>▪ SDD_REQ or Timeout<sup>1</sup></li> </ul>
NFC-B	<ul style="list-style-type: none"> <li>▪ SENSB_REQ</li> <li>▪ ALLB_REQ</li> <li>▪ Either (SENSB_REQ or ALLB_REQ)</li> <li>▪ ATTRIB</li> <li>▪ Arm &amp; Trigger</li> </ul>	<ul style="list-style-type: none"> <li>▪ SENSB_REQ</li> <li>▪ ALLB_REQ</li> <li>▪ Either (SENB_REQ or ALLB_REQ)</li> </ul>	<ul style="list-style-type: none"> <li>▪ ATTRIB or Timeout<sup>1</sup></li> </ul>
NFC-F <sup>2</sup>	<ul style="list-style-type: none"> <li>▪ SENSF_REQ</li> <li>▪ ATR_REQ</li> <li>▪ Preamble</li> <li>▪ Arm &amp; Trigger</li> </ul>	<ul style="list-style-type: none"> <li>▪ SENSF_REQ</li> </ul>	<ul style="list-style-type: none"> <li>▪ ATR_REQ or Timeout<sup>1</sup></li> </ul>

Notes:

- 1 When using the **Arm & Trigger** selection, the oscilloscope arms on one event and then triggers on a second event or after a specified timeout period if the second event does not occur
- 2 Both NFC-F (212 kbps) and NFC-F (424 kbps) are supported.

When the NFC trigger type is selected, there are softkeys for selecting the source, signaling technology standard, trigger event, and other settings:

- 1 Choose **Main Menu > Trigger > Trigger Menu**.
- 2 In the Trigger Menu, click the **Trigger Type** softkey button, and select **Near Field Communication (NFC)**.



- 3 Click the **Source** softkey, and select an analog input channel source.
- 4 Click the **Standard** softkey to select the signaling technology used by the input signal.
- 5 Set the trigger level to capture transitions in the modulation envelope. Or at approximately 50% of the modulation depth. NFC-A uses 100% modulation, so the trigger level can be set in a wide range of values. NFC-B, NFC-F212, and NFC-F424 use 10% modulation, so the trigger level needs to be set to approximately 95% of the unmodulated carrier amplitude. Usually the actual modulation depth is greater than 10%, so the trigger level can be set accordingly.

The following image shows how the trigger level should be set. The Y2 marker is set for the unmodulated carrier amplitude or 123.3 mV. The Y1 marker is set for the maximum modulated amplitude or 97.8 mV. (Note that the actual modulation depth is close to 20%.) The midpoint of the modulation would be  $(123.3 \text{ mV} + 97.8 \text{ mV}) / 2.0 = 110.6 \text{ mV}$ . The trigger level is set to 108 mV; slightly below the mid modulation level to account for trigger hysteresis.

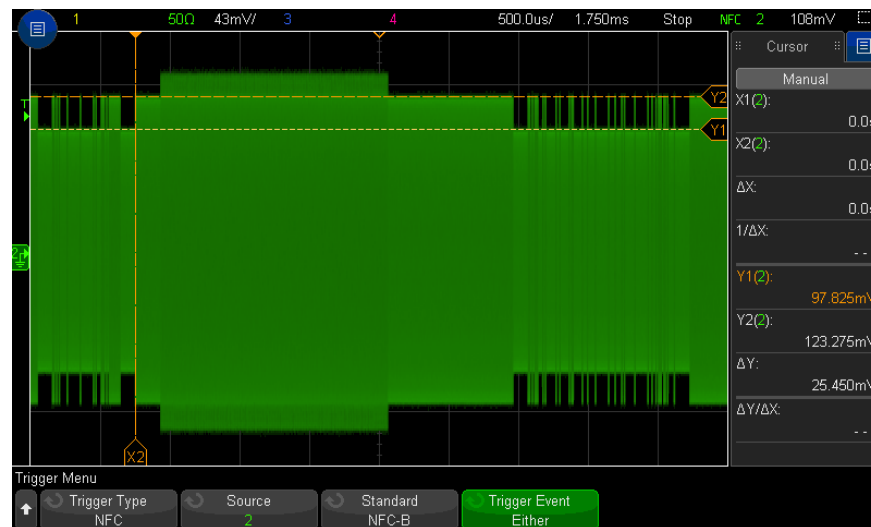

- 6 Click the **Trigger Event** softkey; then, select the event to trigger on. Some of the events you can select are defined in the standards; other event options include:
  - **Either** – With the NFC-A signaling technology, this option means either the SENS\_REQ or ALL\_REQ events will cause a trigger. With the NFC-B signaling technology, this option means either the SENSB\_REQ or ALLB\_REQ events will cause a trigger.
  - **Preamble** – With the NFC-F signaling technologies, this option specifies the preamble sequence that begins a data frame.
  - **Arm & Trigger** – This selection lets you arm the oscilloscope on one event and then trigger on a second event or after a specified timeout period if the second event does not occur.

**7** With the NFC-F standards, there is a **Reverse Polarity** softkey that enables the oscilloscope to trigger on "reverse" polarity signals. When disabled, the oscilloscope triggers on "obverse" polarity signals.

**8** When the **Arm & Trigger** event is selected:

**a** Click the **Arm Event** softkey to select the event to arm on.

When the specified event arms, the signal on the Aux Out MMCX connector goes high. The oscilloscope waits until a second event is found or until the specified timeout period expires and then triggers.

- For NFC-A, the second event is SDD\_REQ.
- For NFC-B, the second event is ATTRIB.
- For NFC-F, the second event is ATR\_REQ.

When the oscilloscope triggers, the signal on Aux Out goes low.

**b** Click the **Timeout** softkey; then, enter the timeout period.

## Nth Edge Burst Trigger

The Nth Edge Burst trigger lets you trigger on the Nth edge of a burst that occurs after an idle time.

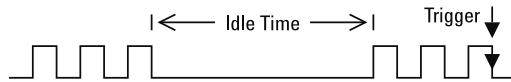

Nth Edge Burst trigger set up consists of selecting the source, the slope of the edge, the idle time, and the number of the edge:

- 1 Choose **Main Menu > Trigger > Trigger Menu**.
- 2 In the Trigger Menu, click the **Trigger Type** softkey button, and select **Nth Edge Burst**.

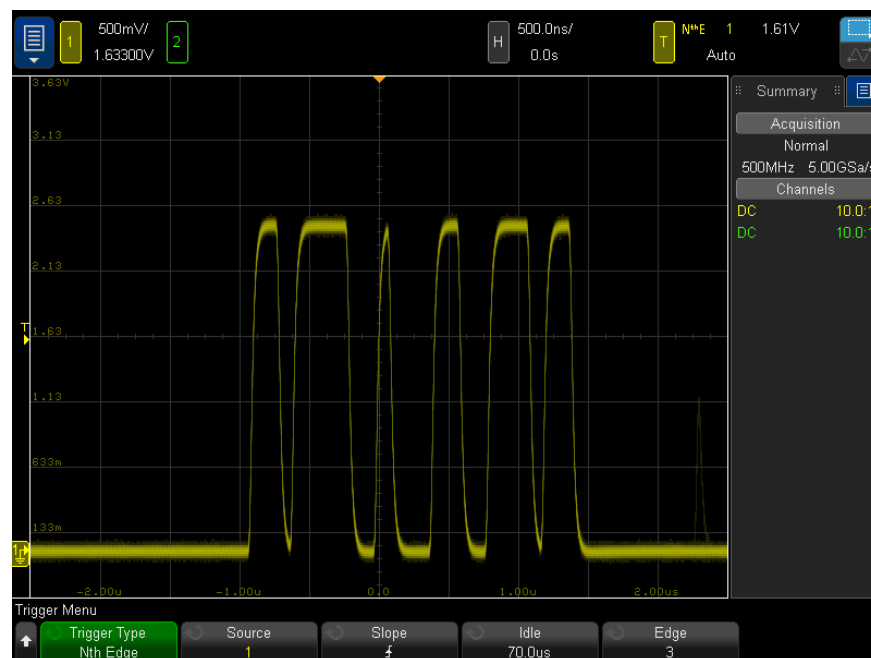

- 3 Click the **Source** softkey, and select the input channel source.
- 4 Click the **Slope** softkey to select the slope of the edge.
- 5 Click the **Idle** softkey; then, enter the idle time.
- 6 Click the **Edge** softkey; then, enter edge number to trigger on.

## Runt Trigger

The Runt trigger looks for pulses that cross one threshold but not another.

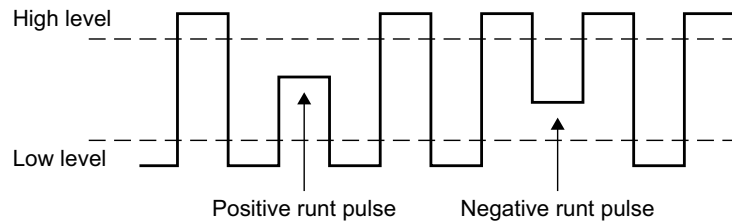

- A positive runt pulse crosses through a lower threshold but not an upper threshold.
- A negative runt pulse crosses through an upper threshold but not a lower threshold.

To trigger on runt pulses:

- 1 Choose **Main Menu > Trigger > Trigger Menu**.
- 2 In the Trigger Menu, click the **Trigger Type** softkey button, and select **Runt**.

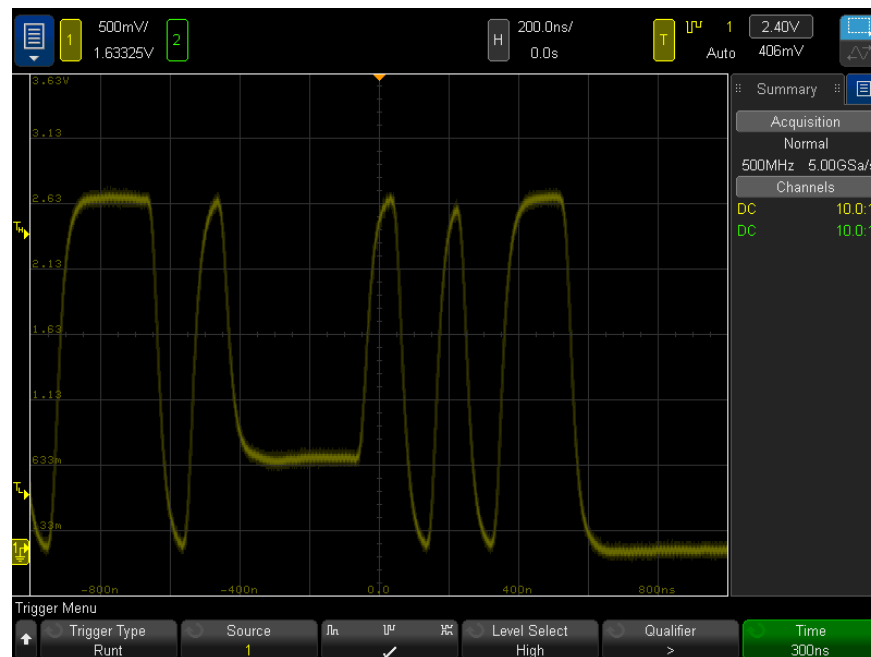

- 3 Click the **Source** softkey, and select the input channel source.
- 4 Click the **Positive**, **Negative**, or **Either Runt Pulse** softkey to toggle between pulse types.

- 5 Click the **Level Select** softkey to select **High**; then, adjust the high level in the upper-right corner of the display.
- 6 Click the **Level Select** softkey to select **Low**; then, adjust the low level in the upper-right corner of the display.
- 7 Click the **Qualifier** softkey to toggle between "less than", "greater than", or **None**.  
This lets you specify that a runt pulse be less than or greater than a certain width.
- 8 If you selected the "less than" or "greater than" **Qualifier**, click the **Time** softkey; then, enter the time.

## Setup and Hold Trigger

The Setup and Hold trigger looks for setup and hold violations.

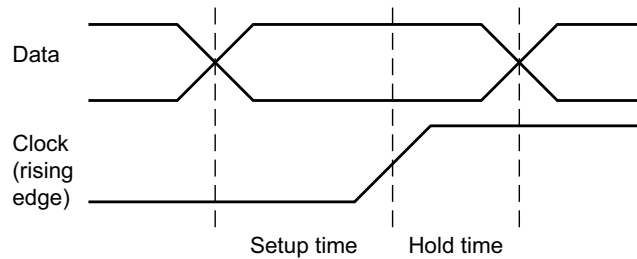

One oscilloscope channel probes the clock signal and another channel probes the data signal.

To trigger on setup and hold violations:

- 1 Choose **Main Menu > Trigger > Trigger Menu**.
- 2 In the Trigger Menu, click the **Trigger Type** softkey button, and select **Setup and Hold**.
- 3 Click the **Clock** softkey; then, select the input channel with the clock signal.
- 4 Set the appropriate trigger level for the clock signal.
- 5 Click the **Rising Edge or Falling Edge** softkey to specify the clock edge being used.
- 6 Click the **Data** softkey; then, select the input channel with the data signal.
- 7 Set the appropriate trigger level for the data signal.
- 8 Click the **< Setup** softkey, and enter the setup time.



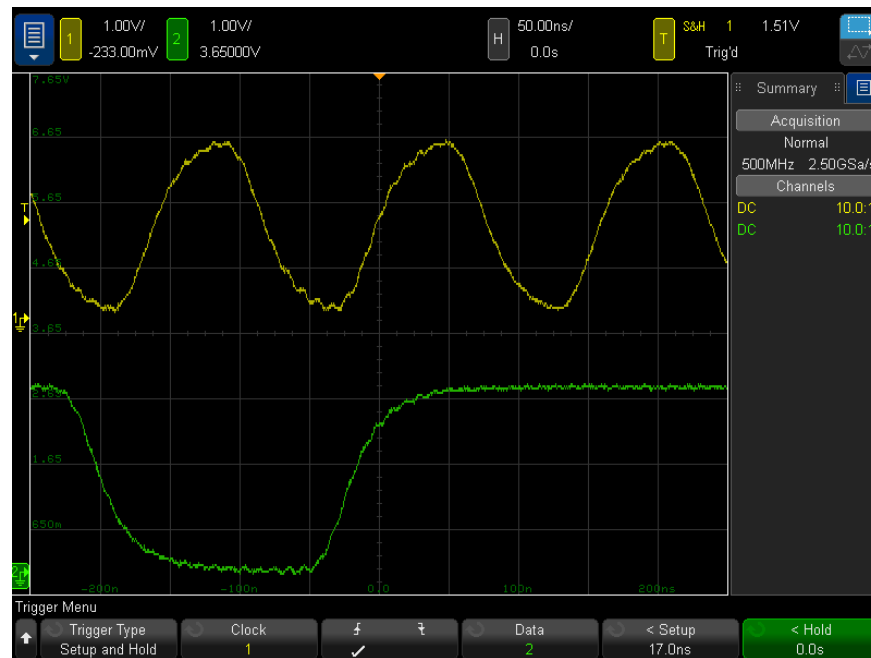

- 9 Click the **< Hold** softkey, and enter the hold time.

## Video Trigger

Video triggering can be used to capture the complicated waveforms of most standard analog video signals. The trigger circuitry detects the vertical and horizontal interval of the waveform and produces triggers based on the video trigger settings you have selected.

The oscilloscope's MegaZoom IV technology gives you bright, easily viewed displays of any part of the video waveform. Analysis of video waveforms is simplified by the oscilloscope's ability to trigger on any selected line of the video signal.

### NOTE

It is important, when using a 10:1 passive probe, that the probe is correctly compensated. The oscilloscope is sensitive to this and will not trigger if the probe is not properly compensated, especially for progressive formats.

- 1 Choose **Main Menu > Trigger > Trigger Menu**.
- 2 In the Trigger Menu, click the **Trigger Type** softkey button, and select **Video**.

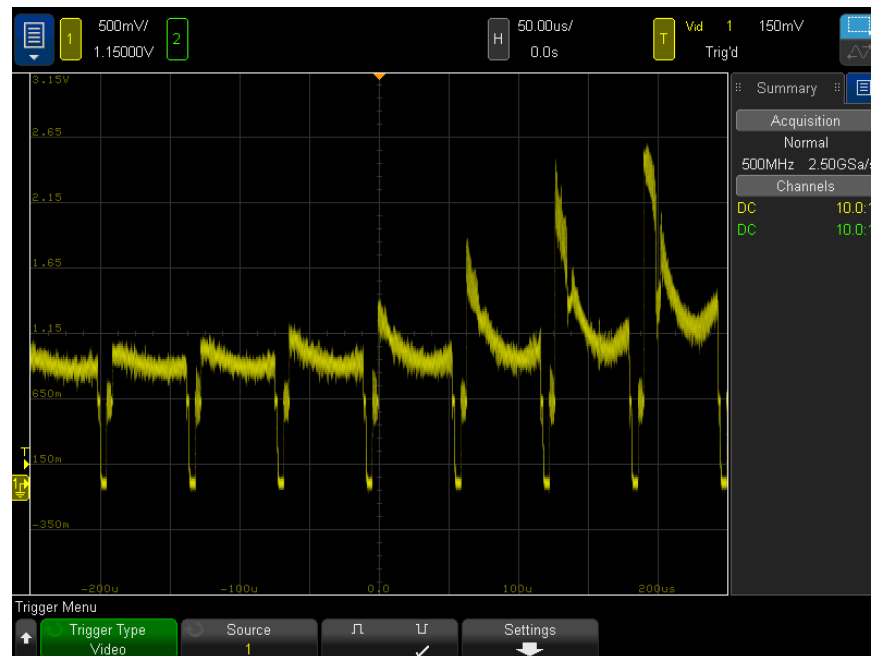

- 3 Click the **Source** softkey and select any analog channel as the video trigger source.

The selected trigger source is displayed in the upper-right corner of the display.

The trigger level must be set between the bottom of the sync pulse and the bottom of the color burst as shown below.

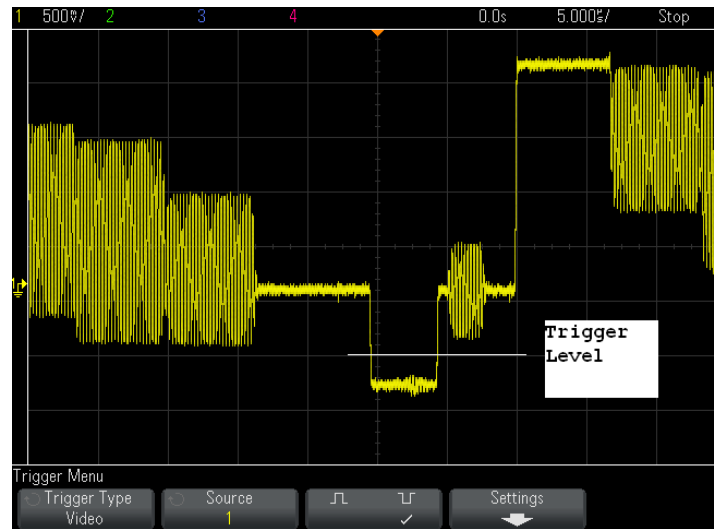

Trigger coupling is automatically set to **DC** in the Trigger Mode and Coupling Menu.

## NOTE

### Provide Correct Matching

Many video signals are produced from 75  $\Omega$  sources. To provide correct matching to these sources, a 75  $\Omega$  terminator (such as a Keysight 11094B) should be connected to the oscilloscope input.

- 4 Click the sync polarity softkey to set the Video trigger to either positive ( $\neg$ ) or negative ( $\neg$ ) sync polarity.
- 5 Click the **Settings** softkey.



- 6 In the Video Trigger Menu, click the **Standard** softkey to set the video standard. The oscilloscope supports triggering on the following television (TV) and video standards.

Standard	Type	Sync Pulse
NTSC	Interlaced	Bi-level
PAL	Interlaced	Bi-level
PAL-M	Interlaced	Bi-level
SECAM	Interlaced	Bi-level

With the P9240VIDA extended video triggering license, the oscilloscope additionally supports these standards:

Standard	Type	Sync Pulse
Generic	Interlaced/Progressive	Bi-level/Tri-level
EDTV 480p/60	Progressive	Bi-level
EDTV 567p/50	Progressive	Bi-level
HDTV 720p/50	Progressive	Tri-level
HDTV 720p/60	Progressive	Tri-level
HDTV 1080p/24	Progressive	Tri-level
HDTV 1080p/25	Progressive	Tri-level
HDTV 1080p/30	Progressive	Tri-level
HDTV 1080p/50	Progressive	Tri-level
HDTV 1080p/60	Progressive	Tri-level
HDTV 1080i/50	Interlaced	Tri-level
HDTV 1080i/60	Interlaced	Tri-level

The **Generic** selection lets you trigger on custom bi-level and tri-level sync video standards. See ["To set up Generic video triggers"](#) on page 158.

- 7 Click the **Auto Setup** softkey to automatically set up the oscilloscope for the selected **Source** and **Standard**:
  - Source channel vertical scaling is set to 140 mV/div.
  - Source channel offset is set to 245 mV.
  - Source channel is turned on.
  - Trigger type is set to **Video**.
  - Video trigger mode is set to **All Lines** (but left unchanged if **Standard** is **Generic**).
  - Display **Grid** type is set to **IRE** (when **Standard** is **NTSC**) or **mV** (see ["To select the grid type"](#) on page 117).
  - Horizontal time/division is set to 10  $\mu$ s/div for NTSC/PAL/SECAM standards or 4  $\mu$ s/div for EDTV or HDTV standards (unchanged for **Generic**).
  - Horizontal delay is set so that trigger is at first horizontal division from the left (unchanged for **Generic**).

You can also choose **Main Menu > Analyze > Analyze Menu**, click **Features**, and then select **Video** to quickly access the video triggering automatic set up and display options.

- 8 Click the **Mode** softkey to select the portion of the video signal that you would like to trigger on.

The Video trigger modes available are:

- **Field1** and **Field2** – Trigger on the rising edge of the first serration pulse of field 1 or field 2 (interlaced standards only).
  - **All Fields** – Trigger on the rising edge of the first pulse in the vertical sync interval.
  - **All Lines** – Trigger on all horizontal sync pulses.
  - **Line** – Trigger on the selected line number (EDTV and HDTV standards only).
  - **Line: Field1** and **Line:Field2** – Trigger on the selected line # in field 1 or field 2 (interlaced standards only).
  - **Line: Alternate** – Alternately trigger on the selected line # in field 1 and field 2 (NTSC, PAL, PAL-M, and SECAM only).
- 9 If you select a line # mode, click the **Line #** softkey, then select the line number on which you want to trigger.

The following table lists the line (or count) numbers per field for each video standard.

Video standard	Field 1	Field 2	Alt Field
NTSC	1 to 263	1 to 262	1 to 262
PAL	1 to 313	314 to 625	1 to 312
PAL-M	1 to 263	264 to 525	1 to 262
SECAM	1 to 313	314 to 625	1 to 312

The following table lists the line numbers for each EDTV/HDTV video standard (available with the P9240VIDA extended video triggering license).

EDTV 480p/60	1 to 525
EDTV 567p/50	1 to 625
HDTV 720p/50, 720p/60	1 to 750
HDTV 1080p/24, 1080p/25, 1080p/30, 1080p/50, 1080p/60	1 to 1125
HDTV 1080i/50, 1080i/60	1 to 1125

### Video Triggering Examples

The following are exercises to familiarize you with video triggering. These exercises use the NTSC video standard.

- **"To trigger on a specific line of video"** on page 158

- "To trigger on all sync pulses" on page 159
- "To trigger on a specific field of the video signal" on page 160
- "To trigger on all fields of the video signal" on page 161
- "To trigger on odd or even fields" on page 162

## To set up Generic video triggers

When **Generic** (available with the P9240VIDA extended video triggering license) is selected as the Video trigger **Standard**, you can trigger on custom bi-level and tri-level sync video standards. The Video Trigger Menu changes as follows.



- 1 Click the **Time >** softkey; then, set the time to greater-than the sync-pulse width so that the oscilloscope synchronizes to the vertical sync.
- 2 Click the **Edge #** softkey; then, select the Nth edge after after vertical sync to trigger on.
- 3 To enable or disable the horizontal sync control, click the first **Horiz Sync** softkey.
  - For interleaved video, enabling the **Horiz Sync** control and setting the **Horiz Sync** adjustment to the sync time of the probed video signal allows the **Edge #** function to count only lines and not double count during equalization. Additionally, the **Field Holdoff** can be adjusted so that the oscilloscope triggers once per frame.
  - Similarly, for progressive video with a tri-level sync, enabling the **Horiz Sync** control and setting the **Horiz Sync** adjustment to the sync time of the probed video signal allows the **Edge #** function to count only lines and not double count during vertical sync.

When the horizontal sync control is enabled, click the second **Horiz Sync** softkey; then, set the minimum time the horizontal sync pulse must be present to be considered valid.

## To trigger on a specific line of video

Video triggering requires greater than 1/2 division of sync amplitude with any analog channel as the trigger source.

One example of triggering on a specific line of video is looking at the vertical interval test signals (VITS), which are typically in line 18. Another example is closed captioning, which is typically in line 21.

- 1 Choose **Main Menu > Trigger > Trigger Menu**.
- 2 In the Trigger Menu, click the **Trigger Type** softkey button, and select **Video**.

- 3 Click the **Settings** softkey, then click the **Standard** softkey to select the appropriate TV standard (NTSC).
- 4 Click the **Mode** softkey and select the TV field of the line you want to trigger on. You can choose **Line:Field1**, **Line:Field2**, or **Line:Alternate**.
- 5 Click the **Line #** softkey and select the number of the line you want to examine.

**NOTE****Alternate Triggering**

If Line:Alternate is selected, the oscilloscope will alternately trigger on the selected line number in Field 1 and Field 2. This is a quick way to compare the Field 1 VITS and Field 2 VITS or to check for the correct insertion of the half line at the end of Field 1.

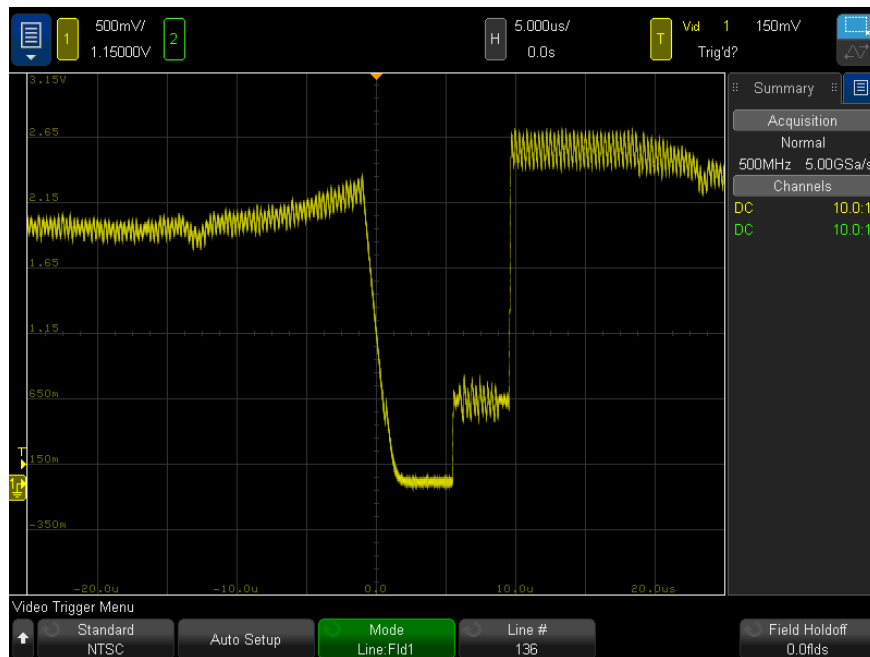

**Figure 20** Example: Triggering on Line 136

### To trigger on all sync pulses

To quickly find maximum video levels, you could trigger on all sync pulses. When **All Lines** is selected as the Video trigger mode, the oscilloscope will trigger on all horizontal sync pulses.

- 1 Choose **Main Menu > Trigger > Trigger Menu**.
- 2 In the Trigger Menu, click the **Trigger Type** softkey button, and select **Video**.
- 3 Click the **Settings** softkey, then click the **Standard** softkey to select the appropriate TV standard.
- 4 Click the **Mode** softkey and select **All Lines**.



**Figure 21** Triggering on All Lines

To trigger on a specific field of the video signal

To examine the components of a video signal, trigger on either Field 1 or Field 2 (available for interleaved standards). When a specific field is selected, the oscilloscope triggers on the rising edge of the first serration pulse in the vertical sync interval in the specified field (1 or 2).

- 1 Choose **Main Menu > Trigger > Trigger Menu**.
- 2 In the Trigger Menu, click the **Trigger Type** softkey button, and select **Video**.
- 3 Click the **Settings** softkey; then, click the **Standard** softkey to select the appropriate TV standard.
- 4 Click the **Mode** softkey and select **Field1** or **Field2**.



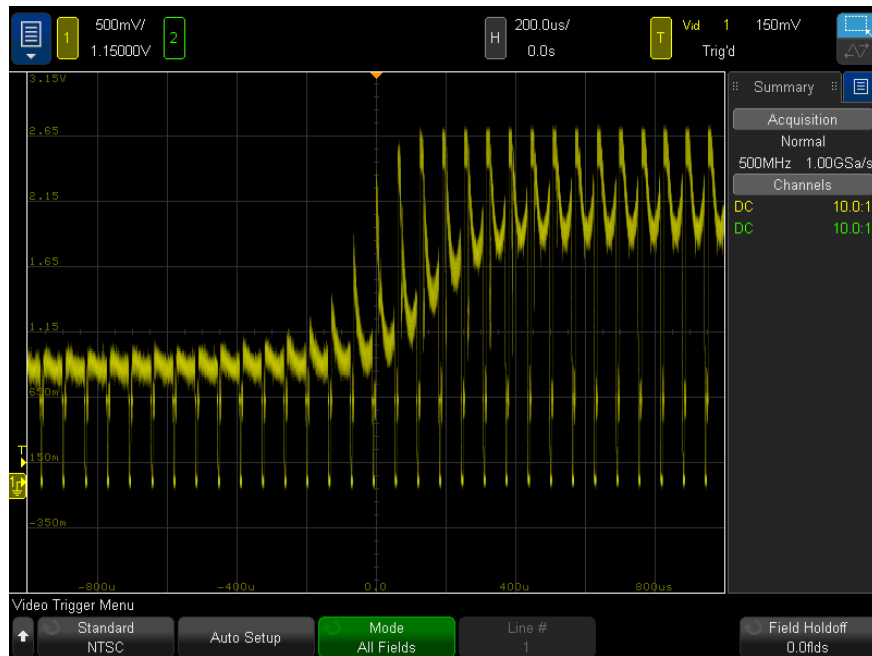

**Figure 22** Triggering on Field 1

To trigger on all fields of the video signal

To quickly and easily view transitions between fields, or to find the amplitude differences between the fields, use the All Fields trigger mode.

- 1 Choose **Main Menu > Trigger > Trigger Menu**.
- 2 In the Trigger Menu, click the **Trigger Type** softkey button, and select **Video**.
- 3 Click the **Settings** softkey, then click the **Standard** softkey to select the appropriate TV standard.
- 4 Click the **Mode** softkey and select **All Fields**.



**Figure 23** Triggering on All Fields

## To trigger on odd or even fields

To check the envelope of your video signals, or to measure worst case distortion, trigger on the odd or even fields. When Field 1 is selected, the oscilloscope triggers on color fields 1 or 3. When Field 2 is selected, the oscilloscope triggers on color fields 2 or 4.

- 1 Choose **Main Menu > Trigger > Trigger Menu**.
- 2 In the Trigger Menu, click the **Trigger Type** softkey button, and select **Video**.
- 3 Click the **Settings** softkey, then click the **Standard** softkey to select the appropriate TV standard.
- 4 Click the **Mode** softkey and select **Field1** or **Field2**.

The trigger circuits look for the position of the start of Vertical Sync to determine the field. But this definition of field does not take into consideration the phase of the reference subcarrier. When Field 1 is selected, the trigger system will find any field where the vertical sync starts on Line 4. In the case of NTSC video, the oscilloscope will trigger on color field 1 alternating with color field 3 (see the following figure). This setup can be used to measure the envelope of the reference burst.



**Figure 24** Triggering on Color Field 1 Alternating with Color Field 3

If a more detailed analysis is required, then only one color field should be selected to be the trigger. You can do this by using the **Field Holdoff** softkey in the Video Trigger Menu. Click the **Field Holdoff** softkey and adjust the holdoff in half-field increments until the oscilloscope triggers on only one phase of the color burst.

A quick way to synchronize to the other phase is to briefly disconnect the signal and then reconnect it. Repeat until the correct phase is displayed.

When holdoff is adjusted using the **Field Holdoff** softkey, the corresponding holdoff time will be displayed in the Trigger Mode and Coupling Menu.

**Table 3** Half-field holdoff time

Standard	Time
NTSC	8.35 ms
PAL	10 ms
PAL-M	10 ms
SECAM	10 ms
Generic	8.35 ms
EDTV 480p/60	8.35 ms
EDTV 567p/50	10 ms
HDTV 720p/50	10 ms
HDTV 720p/60	8.35 ms
HDTV 1080p/24	20.835 ms
HDTV 1080p/25	20 ms
HDTV 1080p/30	20 ms
HDTV 1080p/50	16.67 ms
HDTV 1080p/60	8.36 ms
HDTV 1080i/50	10 ms
HDTV 1080i/60	8.35 ms

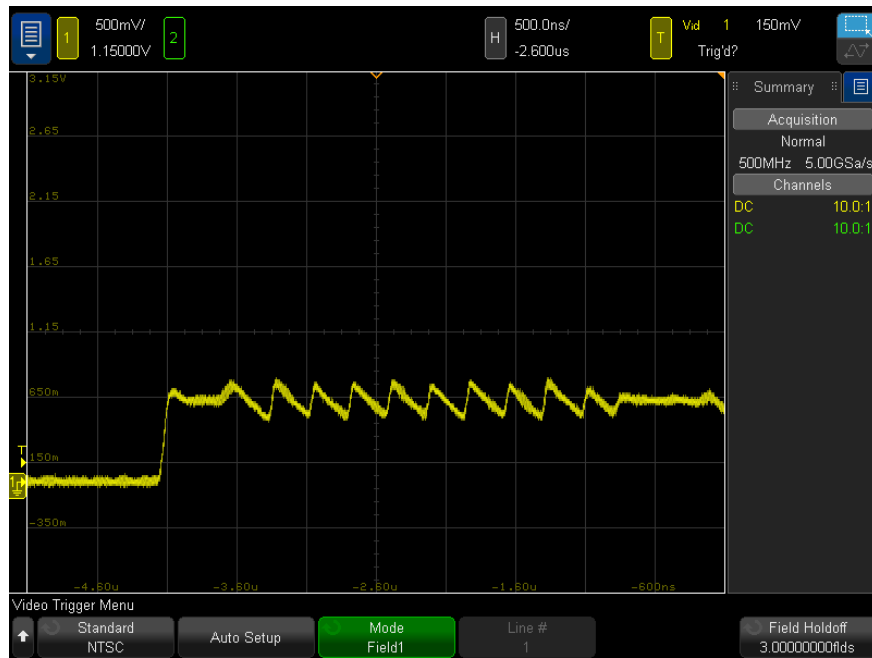

**Figure 25** Using Field Holdoff to Synchronize to Color Field 1 or 3 (Field 1 mode)

## Serial Trigger

With serial decode option licenses (see **"Serial Decode Options"** on page 106), you can enable serial trigger types. To set up these triggers, see:

- **"ARINC 429 Triggering"** on page 390
- **"CAN/CAN FD Triggering"** on page 326
- **"CXPI Triggering"** on page 345
- **"I2C Triggering"** on page 355
- **"LIN Triggering"** on page 337
- **"Manchester Triggering"** on page 367
- **"MIL-STD-1553 Triggering"** on page 383
- **"NRZ Triggering"** on page 375
- **"SENT Triggering"** on page 402
- **"UART/RS232 Triggering"** on page 412
- **"USB PD Triggering"** on page 421

## Zone Qualified Trigger

The zone qualified trigger feature gives you one or two rectangular areas, Zone 1 and Zone 2, that a waveform must either intersect or not intersect in order for an acquisition to be displayed and stored in memory.

The zone qualified trigger feature works on top of the oscilloscope's hardware trigger, which determines the acquisitions whose waveforms are evaluated for zone intersection.

To set up a zone qualified trigger:

- 1 Click the upper-right corner to select the rectangle draw mode.



- 2 Drag across the screen to draw a rectangular zone that the waveform must either intersect or not intersect.
- 3 Release the mouse button.
- 4 In the popup menu, select whether the rectangle is Zone 1 or Zone 2 and whether it is a "Must Intersect" or "Must Not Intersect" zone.

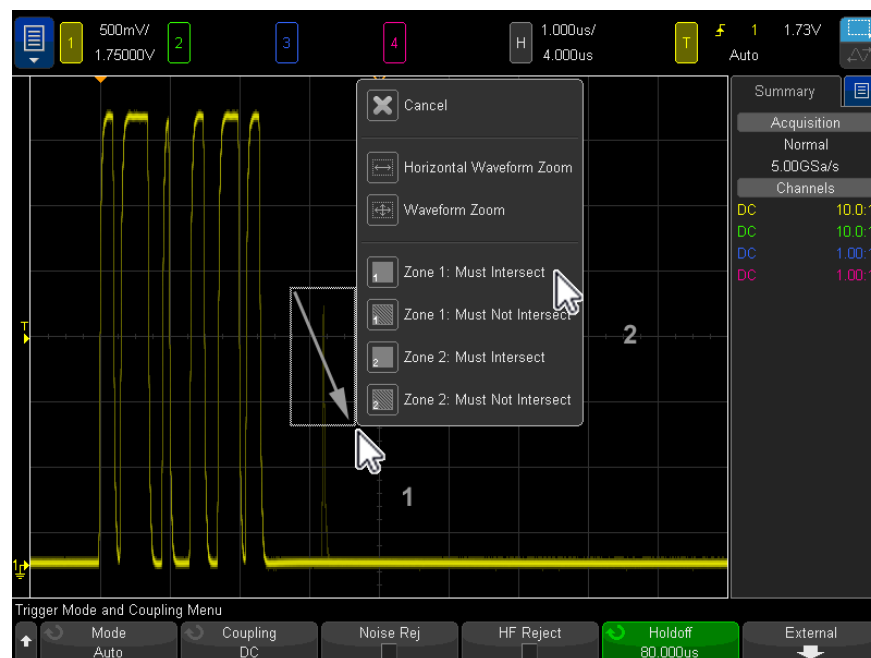

The **Main Menu > Trigger > Zone Qualified Trigger** menu item shows the zone qualified trigger feature is enabled.

- 5 In the Zone Qualified Trigger Menu, click the **Source** softkey and select the analog channel input source that both zones are associated with.



Zone colors match the selected analog input channel. "Must Not Intersect" zones are shaded differently than the solid "Must Intersect" zones.

The zone qualified trigger source does not have to be the same as the hardware trigger source.

- 6 You can use the **Zone 1 On** and **Zone 2 On** softkeys to disable or enable zones, and you can use the **Zone 1** and **Zone 2** softkeys to toggle between the "Must Intersect" and "Must Not Intersect" conditions.

Disabling both zones disables the zone qualified trigger feature. When the zone qualified trigger feature is enabled, at least one zone must be enabled.

You can choose **Main Menu > Trigger > Zone Qualified Trigger** to disable or re-enable the zone qualified trigger.

When two non-overlapping zones are used, their conditions are ANDed to become the final qualifying condition.

When two overlapping zones have the must intersect condition, the zones are ORed. When two overlapping zones have different conditions, Zone 1 takes precedence and Zone 2 is not used. In this case, Zone 2 will have no fill (that is, neither solid nor shaded) to indicate that it is not being used.

The zone qualified trigger feature is incompatible with, and will disable, the Averaging acquisition mode.

#### NOTE

Keep in mind that the Aux Out signal comes from the oscilloscope's hardware trigger. The Aux Out signal indicates when there is a trigger (acquisition) that is evaluated for zone intersection, not when an acquisition meets the zone qualification and is plotted on the oscilloscope's display.



# 10 Trigger Mode/Coupling

To select the Auto or Normal trigger mode / 170

To select the trigger coupling / 172

To enable or disable trigger noise rejection / 173

To enable or disable trigger HF Reject / 174

To set the trigger holdoff / 175

External Trigger Input / 176

To access the Trigger Mode and Coupling Menu:

- Choose **Main Menu > Trigger > Trigger Mode and Coupling Menu.**

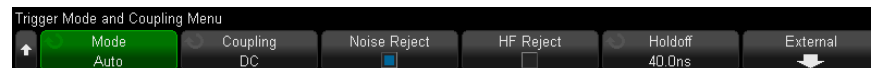

**Noisy Signals** If the signal you are probing is noisy, you can set up the oscilloscope to reduce the noise in the trigger path and on the displayed waveform. First, stabilize the displayed waveform by removing the noise from the trigger path. Second, reduce the noise on the displayed waveform.

- 1 Connect a signal to the oscilloscope and obtain a stable display.
- 2 Remove the noise from the trigger path by turning on high-frequency rejection ("**To enable or disable trigger HF Reject**" on page 174), low-frequency rejection ("**To select the trigger coupling**" on page 172), or "**To enable or disable trigger noise rejection**" on page 173.
- 3 Use "**Averaging Acquisition Mode**" on page 187 to reduce noise on the displayed waveform.

## To select the Auto or Normal trigger mode

When the oscilloscope is running, the trigger mode tells the oscilloscope what to do when triggers are not occurring.

In the **Auto** trigger mode (the default setting), if the specified trigger conditions are not found, triggers are forced and acquisitions are made so that signal activity is displayed on the oscilloscope.

In the **Normal** trigger mode, triggers and acquisitions only occur when the specified trigger conditions are found.

To select the trigger mode:

- 1 Choose **Main Menu > Trigger > Trigger Mode and Coupling Menu**.
- 2 In the Trigger Mode and Coupling Menu, click the **Mode** softkey; then select either **Auto** or **Normal**.

You can also make this selection by clicking the Run/Stop status in the upper-right corner of the display. See "[Access the Trigger Menu, Change the Trigger Mode, and Open the Trigger Level Dialog Box](#)" on page 32.

See the following "[When to Use Auto Trigger Mode](#)" on page 171 and "[When to Use Normal Trigger Mode](#)" on page 171 descriptions.

You can also configure the **Main Menu > Quick Action** menu item to toggle between the Auto and Normal trigger modes. See "[Configuring the Quick Action Menu Item](#)" on page 304.

### Triggering and the Pre- and Post-Trigger Buffers

After the oscilloscope starts running (after choosing **Main Menu > Run/Stop** or **Main Menu > Single** or changing the trigger condition), the oscilloscope first fills the pre-trigger buffer. Then, after the pre-trigger buffer is filled, the oscilloscope starts searching for a trigger, and sampled data continues to flow data through the pre-trigger buffer in a first-in first-out (FIFO) manner.

When a trigger is found, the pre-trigger buffer contains the events that occurred just before the trigger. Then, the oscilloscope fills the post-trigger buffer and displays the acquisition memory. If the acquisition was initiated by **Main Menu > Run/Stop**, the process repeats. If the acquisition was initiated by choosing **Main Menu > Single**, the acquisition stops (and you can Pan and Zoom the waveform).

In either Auto or Normal trigger mode, a trigger may be missed if the event occurs while the pre-trigger buffer is being filled. This may be more likely, for example, when the horizontal scale is set to a slow time/div setting, such as 500 ms/div.

### Trigger Indicator

The trigger indicator at the top right of the display shows whether triggers are occurring.

In the **Auto** trigger mode, the trigger indicator can show:

- **Auto?**— the trigger condition is not found (after the pre-trigger buffer has filled), and forced triggers and acquisitions are occurring.
- **Auto** — the trigger condition is found (or the pre-trigger buffer is being filled).

In the **Normal** trigger mode, the trigger indicator can show:

- **Trig'd?**— the trigger condition is not found (after the pre-trigger buffer has filled), and no acquisitions are occurring.
- **Trig'd**— trigger condition is found (or pre-trigger buffer is being filled).

When the oscilloscope is not running, the trigger indicator area shows **Stop**.

#### When to Use Auto Trigger Mode

The **Auto** trigger mode is appropriate when:

- Checking DC signals or signals with unknown levels or activity.
- When trigger conditions occur often enough that forced triggers are unnecessary.

#### When to Use Normal Trigger Mode

The **Normal** trigger mode is appropriate when:

- You only want to acquire specific events specified by the trigger settings.
- Triggering on an infrequent signal from a serial bus (for example, I2C, CAN, LIN, etc.) or another signal that arrives in bursts. The **Normal** trigger mode lets you stabilize the display by preventing the oscilloscope from auto-triggering.
- Making single-shot acquisitions with **Main Menu > Single**.

Often with single-shot acquisitions, you must initiate some action in the device under test, and you do not want the oscilloscope to auto-trigger before that happens. Before initiating the action in the circuit, wait for the trigger condition indicator **Trig'd?** to display (this tells you the pre-trigger buffer is filled).

#### See Also

- **"Forcing a Trigger"** on page 132
- **"To set the trigger holdoff"** on page 175
- **"To position the time reference (left, center, right, custom)"** on page 46

## To select the trigger coupling

- 1 Choose **Main Menu > Trigger > Trigger Mode and Coupling Menu**.
- 2 In the Trigger Mode and Coupling Menu, click the **Coupling** softkey; then, select:
  - **DC** coupling – allows DC and AC signals into the trigger path.
  - **AC** coupling – places a 10 Hz high-pass filter in the trigger path removing any DC offset voltage from the trigger waveform.

The high-pass filter in the External Trigger input path is 50 Hz for all models.

Use AC coupling to get a stable edge trigger when your waveform has a large DC offset.

- **LF (low frequency) Reject** coupling – adds a high-pass filter with the 3-dB point at 50 kHz in series with the trigger waveform.

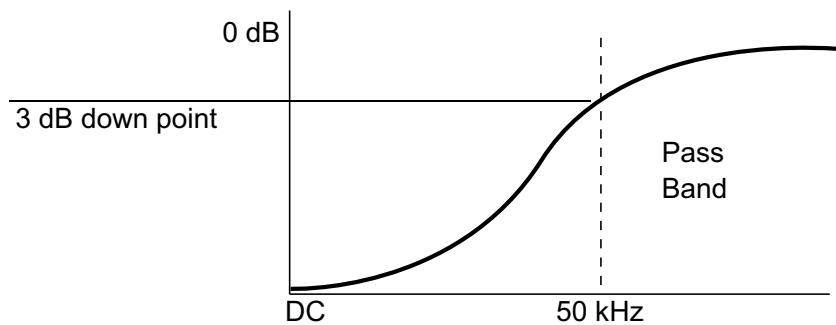

Low frequency reject removes any unwanted low frequency components from a trigger waveform, such as power line frequencies, etc., that can interfere with proper triggering.

Use **LF Reject** coupling to get a stable edge trigger when your waveform has low frequency noise.

- **Video** coupling – is always grayed-out in the P9241/42/43A oscilloscopes.

Note that Trigger Coupling is independent of Channel Coupling (see **"To specify channel coupling"** on page 56).

## To enable or disable trigger noise rejection

Noise Rej adds additional hysteresis to the trigger circuitry. By increasing the trigger hysteresis band, you reduce the possibility of triggering on noise. However, this also decreases the trigger sensitivity so that a slightly larger signal is required to trigger the oscilloscope.

- 1 Choose **Main Menu > Trigger > Trigger Mode and Coupling Menu**.
- 2 In the Trigger Mode and Coupling Menu, click the **Noise Rej** softkey to enable or disable.

## To enable or disable trigger HF Reject

HF Reject adds a 50 kHz low-pass filter in the trigger path to remove high frequency components from the trigger waveform.

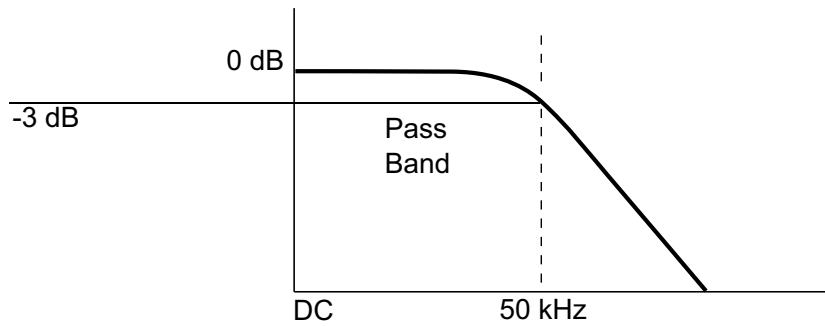

You can use HF Reject to remove high-frequency noise, such as AM or FM broadcast stations or noise from fast system clocks, from the trigger path.

- 1 Choose **Main Menu > Trigger > Trigger Mode and Coupling Menu**.
- 2 In the Trigger Mode and Coupling Menu, click the **HF Reject** softkey to enable or disable.

## To set the trigger holdoff

Trigger holdoff sets the amount of time the oscilloscope waits after a trigger before re-arming the trigger circuitry.

Use the holdoff to trigger on repetitive waveforms that have multiple edges (or other events) between waveform repetitions. You can also use holdoff to trigger on the first edge of a burst when you know the minimum time between bursts.

For example, to get a stable trigger on the repetitive pulse burst shown below, set the holdoff time to be >200 ns but <600 ns.

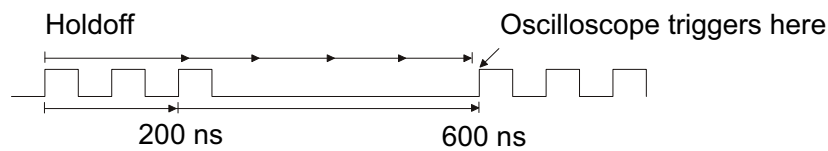

To set the trigger holdoff:

- 1 Choose **Main Menu > Trigger > Trigger Mode and Coupling Menu**.
- 2 In the Trigger Mode and Coupling Menu, click **Holdoff**.
- 3 In the Trigger Holdoff Menu, click the **Random** softkey to enable or disable the random trigger holdoff mode.

The random trigger holdoff mode ensures that the oscilloscope re-arms after each acquisition in a manner that minimizes or eliminates the likelihood of triggering at the beginning of a DDR burst. Randomizing the holdoff time increases the likelihood that the oscilloscope will trigger on different data phases of a multi-phase (8 data transfer) burst. This mode mixes up the traffic pattern the oscilloscope triggers on and is very effective when used on repeating patterns.

- 4 If random trigger holdoff is disabled, use the **Holdoff** softkey to enter the trigger holdoff time.

If random trigger holdoff is enabled, use the **Min** and **Max** softkeys to enter the minimum and maximum trigger holdoff times.

### Trigger Holdoff Operating Hints

The correct holdoff setting is typically slightly less than one repetition of the waveform. Set the holdoff to this time to generate a unique trigger point for a repetitive waveform.

Changing the time base settings does not affect the trigger holdoff time.

With Keysight's MegaZoom technology, you can stop acquisitions, then pan and zoom through the data to find where the waveform repeats. Measure this time using cursors; then, set the holdoff.

## External Trigger Input

The external trigger input can be used as a source in several of the trigger types. The external trigger MMCX input is labeled **Ext Trig**.

### CAUTION

#### **Maximum voltage at oscilloscope external trigger input**

30 Vrms, 60 Vdc

1M ohm input: For steady-state sinusoidal waveforms derate at 20 dB/decade above 100 kHz to a minimum of 5 Vpk

The external trigger input impedance is 1M Ohm. This lets you use passive probes for general-purpose measurements. The higher impedance minimizes the loading effect of the oscilloscope on the device under test.

To set the Ext Trig units and probe attenuation:

- 1 Choose **Main Menu > Trigger > Trigger Mode and Coupling Menu**.



- 2 In the Trigger Mode and Coupling Menu, click the **External** softkey.



- 3 In the External Trigger Menu, click the **Units** softkey to select between:
  - **Volts** – for a voltage probe.
  - **Amps** – for a current probe.

Measurement results, channel sensitivity, and the trigger level will reflect the measurement units you have selected.

- 4 Click the **Probe** softkey; then, enter the probe attenuation.

The attenuation factor can be set from 0.1:1 to 10000:1 in a 1-2-5 sequence.

The probe attenuation factor must be set properly for measurements to be made correctly.



# 11 Acquisition Control

Running, Stopping, and Making Single Acquisitions (Run Control) / 178

Overview of Sampling / 180

Selecting the Acquisition Mode / 184

Realtime Sampling Option / 190

Acquiring to Segmented Memory / 191

This chapter shows how to use the oscilloscope's acquisition and run controls.

## Running, Stopping, and Making Single Acquisitions (Run Control)

There are keyboard shortcuts and main menu items for starting and stopping the oscilloscope's acquisition system.

The keyboard shortcuts are:

- F5 – Run
- F6 – Stop
- F10 – Single

The main menu items are:

- **Main Menu > Run/Stop**
- **Main Menu > Single**

The acquisition states work like this:

- When the oscilloscope is running, it is acquiring data when trigger conditions are met.

To stop acquiring data, choose **Main Menu > Run/Stop** (or F6 on the keyboard). When stopped, the last acquired waveform is displayed.

- When data acquisition is stopped, "Stop" is displayed next to the trigger type in the status line at the top of the display.

To start acquiring data, choose **Main Menu > Run/Stop** (or F5 on the keyboard).

- To capture and display a single acquisition (whether the oscilloscope is running or stopped), choose **Main Menu > Single** (or F10 on the keyboard).

Single acquisitions let you view single-shot events without subsequent waveform data overwriting the display. Make single acquisitions when you want maximum memory depth for pan and zoom.

When you start a single acquisition, the trigger mode is temporarily set to Normal (to keep the oscilloscope from auto-triggering immediately), the trigger circuitry is armed, and the oscilloscope waits until a trigger condition occurs before it displays a waveform.

When the oscilloscope triggers, the single acquisition is displayed and the oscilloscope is stopped. Choose **Main Menu > Single** (or F10 on the keyboard) again to acquire another waveform.

If the oscilloscope does not trigger, you can choose **Main Menu > Trigger > Force Trigger** to trigger on anything and make a single acquisition.

To display the results of multiple acquisitions, use persistence. See **"To set or clear persistence"** on page 114.

### Single vs. Running and Record Length

The maximum data record length is greater for a single acquisition than when the oscilloscope is running (or when the oscilloscope is stopped after running):

- **Single** – Single acquisitions always use the maximum memory available – at least twice as much memory as acquisitions captured when running – and the oscilloscope stores at least twice as many samples. At slower time/div settings, because there is more memory available for a single acquisition, the acquisition has a higher effective sample rate.
- **Running** – When running (versus taking a single acquisition), the memory is divided in half. This lets the acquisition system acquire one record while processing the previous acquisition, dramatically improving the number of waveforms per second processed by the oscilloscope. When running, a high waveform update rate provides the best representation of your input signal.

To acquire data with the longest possible record length, choose **Main Menu > Single**.

For more information on settings that affect record length, see "**Length Control**" on page 285.

## Overview of Sampling

To understand the oscilloscope's sampling and acquisition modes, it is helpful to understand sampling theory, aliasing, oscilloscope bandwidth and sample rate, oscilloscope rise time, oscilloscope bandwidth required, and how memory depth affects sample rate.

### Sampling Theory

The Nyquist sampling theorem states that for a limited bandwidth (band-limited) signal with maximum frequency  $f_{MAX}$ , the equally spaced sampling frequency  $f_S$  must be greater than twice the maximum frequency  $f_{MAX}$ , in order to have the signal be uniquely reconstructed without aliasing.

$$f_{MAX} = f_S/2 = \text{Nyquist frequency } (f_N) = \text{folding frequency}$$

### Aliasing

Aliasing occurs when signals are under-sampled ( $f_S < 2f_{MAX}$ ). Aliasing is the signal distortion caused by low frequencies falsely reconstructed from an insufficient number of sample points.

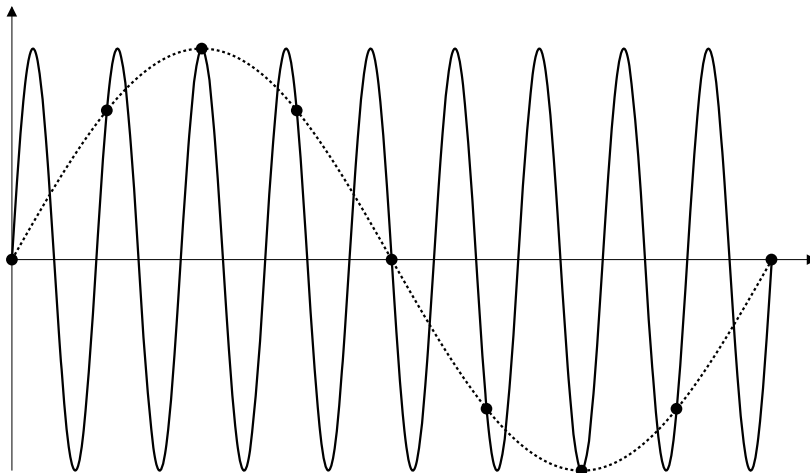
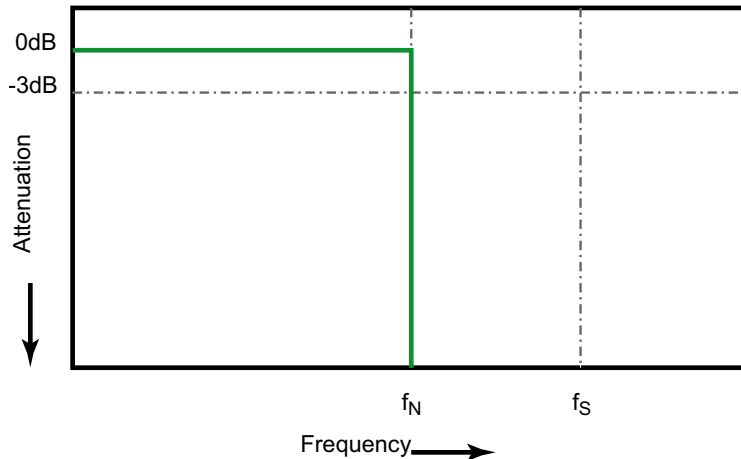

**Figure 26** Aliasing

### Oscilloscope Bandwidth and Sample Rate

An oscilloscope's bandwidth is typically described as the lowest frequency at which input signal sine waves are attenuated by 3 dB (-30% amplitude error).

At the oscilloscope bandwidth, sampling theory says the required sample rate is  $f_s = 2f_{BW}$ . However, the theory assumes there are no frequency components above  $f_{MAX}$  ( $f_{BW}$  in this case) and it requires a system with an ideal brick-wall frequency response.



**Figure 27** Theoretical Brick-Wall Frequency Response

However, digital signals have frequency components above the fundamental frequency (square waves are made up of sine waves at the fundamental frequency and an infinite number of odd harmonics), and typically, for 500 MHz bandwidths and below, oscilloscopes have a Gaussian frequency response.

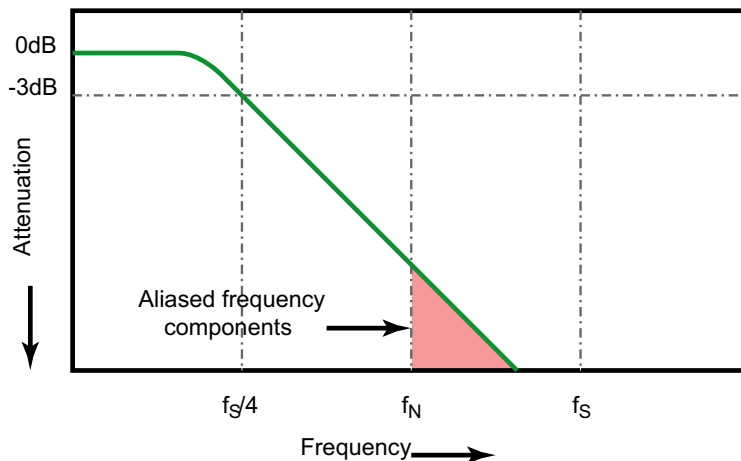

Limiting oscilloscope bandwidth ( $f_{BW}$ ) to 1/4 the sample rate ( $f_s/4$ ) reduces frequency components above the Nyquist frequency ( $f_N$ ).

**Figure 28** Sample Rate and Oscilloscope Bandwidth

So, in practice, an oscilloscope's sample rate should be four or more times its bandwidth:  $f_s = 4f_{BW}$ . This way, there is less aliasing, and aliased frequency components have a greater amount of attenuation.

Note that the P9241/42/43A oscilloscope models have a Gaussian response. To understand the characteristics of each type of oscilloscope frequency response, see *Understanding Oscilloscope Frequency Response and Its Effect on Rise-Time Accuracy*, Keysight Application Note 1420

(<http://literature.cdn.keysight.com/litweb/pdf/5988-8008EN.pdf>).

**See Also** *Evaluating Oscilloscope Sample Rates vs. Sampling Fidelity: How to Make the Most Accurate Digital Measurements*, Keysight Application Note 1587  
(<http://literature.cdn.keysight.com/litweb/pdf/5989-5732EN.pdf>)

## Oscilloscope Rise Time

Closely related to an oscilloscope's bandwidth specification is its rise time specification. Oscilloscopes with a Gaussian-type frequency response have an approximate rise time of  $0.35/f_{BW}$  based on a 10% to 90% criterion.

An oscilloscope's rise time is not the fastest edge speed that the oscilloscope can accurately measure. It is the fastest edge speed the oscilloscope can possibly produce.

## Oscilloscope Bandwidth Required

The oscilloscope bandwidth required to accurately measure a signal is primarily determined by the signal's rise time, not the signal's frequency. You can use these steps to calculate the oscilloscope bandwidth required:

- 1 Determine the fastest edge speeds.

You can usually obtain rise time information from published specifications for devices used in your designs.

- 2 Compute the maximum "practical" frequency component.

From Dr. Howard W. Johnson's book, *High-Speed Digital Design – A Handbook of Black Magic*, all fast edges have an infinite spectrum of frequency components. However, there is an inflection (or "knee") in the frequency spectrum of fast edges where frequency components higher than  $f_{knee}$  are insignificant in determining the shape of the signal.

$$f_{knee} = 0.5 / \text{signal rise time (based on 10\% - 90\% thresholds)}$$

$$f_{knee} = 0.4 / \text{signal rise time (based on 20\% - 80\% thresholds)}$$

- 3 Use a multiplication factor for the required accuracy to determine the oscilloscope bandwidth required.

Required accuracy	Oscilloscope band width required
20%	$f_{BW} = 1.0 \times f_{knee}$
10%	$f_{BW} = 1.3 \times f_{knee}$
3%	$f_{BW} = 1.9 \times f_{knee}$

**See Also** *Choosing an Oscilloscope with the Right Bandwidth for your Application*, Keysight Application Note 1588  
<http://literature.cdn.keysight.com/litweb/pdf/5989-5733EN.pdf>)

## Memory Depth and Sample Rate

The number of points of oscilloscope memory is fixed, and there is a maximum sample rate associated with oscilloscope's analog-to-digital converter; however, the actual sample rate is determined by the time of the acquisition (which is set according to the oscilloscope's horizontal time/div scale).

$$\text{sample rate} = \text{number of samples} / \text{time of acquisition}$$

For example, when storing 50  $\mu$ s of data in 50,000 points of memory, the actual sample rate is 1 GSa/s.

Likewise, when storing 50 ms of data in 50,000 points of memory, the actual sample rate is 1 MSa/s.

The actual sample rate is displayed in the Summary box in the right-side information area.

The oscilloscope achieves the actual sample rate by throwing away (decimating) unneeded samples.

## Selecting the Acquisition Mode

When selecting the oscilloscope acquisition mode, keep in mind that samples are normally decimated at slower time/div settings.

At slower time/div settings, the effective sample rate drops (and the effective sample period increases) because the acquisition time increases and the oscilloscope's digitizer is sampling faster than is required to fill memory.

For example, suppose an oscilloscope's digitizer has a sample period of 1 ns (maximum sample rate of 1 GSa/s) and a 1 M memory depth. At that rate, memory is filled in 1 ms. If the acquisition time is 100 ms (10 ms/div), only 1 of every 100 samples is needed to fill memory.

To select the acquisition mode:

- 1 Choose **Main Menu > Setup > Acquire Menu**.
- 2 In the Acquire Menu, click the **Acq Mode** softkey; then, select the acquisition mode.

The InfiniiVision oscilloscopes have the following acquisition modes:

- **Normal** – at slower time/div settings, normal decimation occurs, and there is no averaging. Use this mode for most waveforms. See "**Normal Acquisition Mode**" on page 184.
- **Peak Detect** – at slower time/div settings, the maximum and minimum samples in the effective sample period are stored. Use this mode for displaying narrow pulses that occur infrequently. See "**Peak Detect Acquisition Mode**" on page 185.
- **Averaging** – at all time/div settings, the specified number of triggers are averaged together. Use this mode for reducing noise and increasing resolution of periodic signals without bandwidth or rise time degradation. See "**Averaging Acquisition Mode**" on page 187.
- **High Resolution** – at slower time/div settings, all samples in the effective sample period are averaged and the average value is stored. Use this mode for reducing random noise. See "**High Resolution Acquisition Mode**" on page 189.

### Normal Acquisition Mode

In Normal mode at slower time/div settings, extra samples are decimated (in other words, some are thrown away). This mode yields the best display for most waveforms.



## Peak Detect Acquisition Mode

In Peak Detect mode at slower time/div settings, minimum and maximum samples are kept in order to capture infrequent and narrow events (at the expense of exaggerating any noise). This mode displays all pulses that are at least as wide as the sample period.

For P9241/42/43A oscilloscopes, which have a maximum sample rate of 5 GSa/s, a sample is taken every 200 ps (sample period).

- See Also
- ["Glitch or Narrow Pulse Capture"](#) on page 185
  - ["Using Peak Detect Mode to Find a Glitch"](#) on page 186

### Glitch or Narrow Pulse Capture

A glitch is a rapid change in the waveform that is usually narrow as compared to the waveform. Peak detect mode can be used to more easily view glitches or narrow pulses. In peak detect mode, narrow glitches and sharp edges are displayed more brightly than when in Normal acquire mode, making them easier to see.

To characterize the glitch, use the cursors or the automatic measurement capabilities of the oscilloscope.

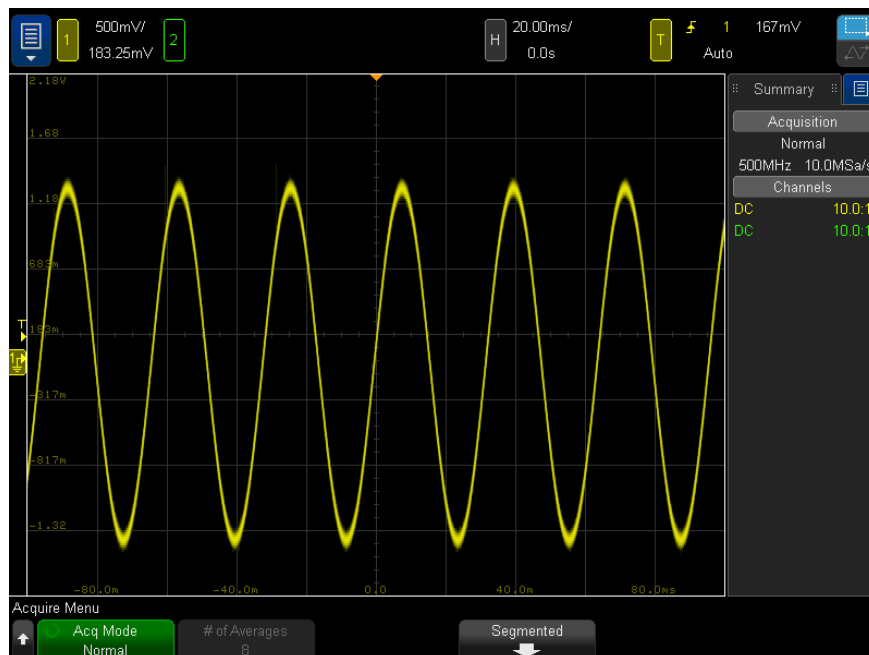

**Figure 29** Sine With Glitch, Normal Mode

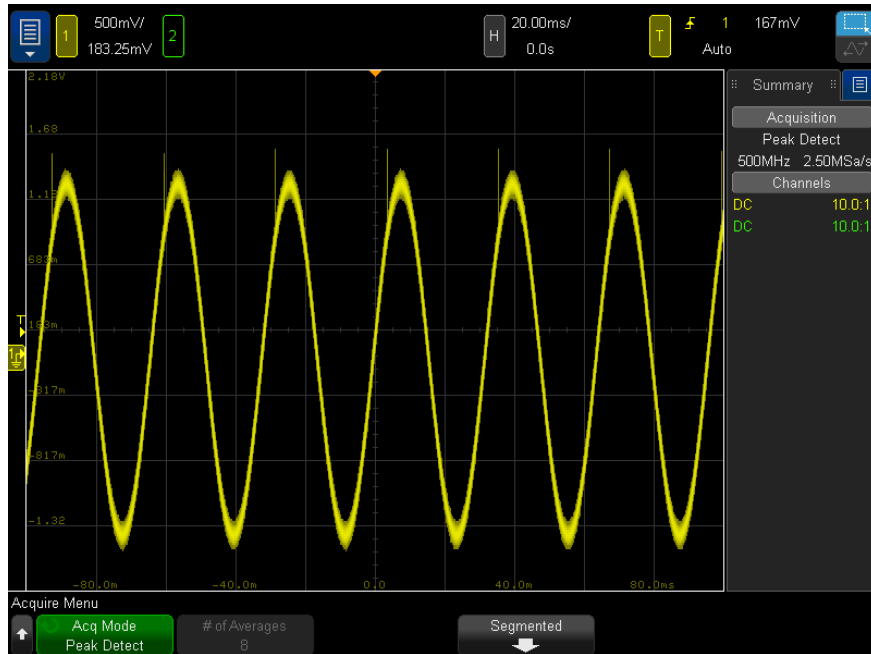

**Figure 30** Sine With Glitch, Peak Detect Mode

### Using Peak Detect Mode to Find a Glitch

- 1 Connect a signal to the oscilloscope and obtain a stable display.
- 2 To find a glitch, choose **Main Menu > Setup > Acquire Menu**; then, click the **Acq Mode** softkey until **Peak Detect** is selected.
- 3 Choose **Main Menu > Setup > Display Menu**; then click the  $\infty$  **Persistence** (infinite persistence) softkey.

Infinite persistence updates the display with new acquisitions but does not erase previous acquisitions. New sample points are shown at normal intensity while previous acquisitions are displayed at reduced intensity. Waveform persistence is not kept beyond the display area boundary.

Click the **Clear Display** softkey to erase previously acquired points. The display will accumulate points until  $\infty$  **Persistence** is turned off.

- 4 Characterize the glitch with Zoom mode:
  - a Choose **Main Menu > Setup > Zoom Mode**.
  - b To obtain a better resolution of the glitch, expand the time base.

Adjust the horizontal position to pan through the waveform to set the expanded portion of the normal window around the glitch.

## Averaging Acquisition Mode

The Averaging mode lets you average multiple acquisitions together to reduce noise and increase vertical resolution (at all time/div settings). Averaging requires a stable trigger.

The number of averages can be set from 2 to 65536 in power-of-2 increments.

A higher number of averages reduces noise more and increases vertical resolution.

# Avgs	Bits of resolution
2	8
4	9
16	10
64	11
≥ 256	12

The higher the number of averages, the slower the displayed waveform responds to waveform changes. You must compromise between how quickly the waveform responds to changes and how much you want to reduce the displayed noise on the signal.

To use the Averaging mode:

- 1 Choose **Main Menu > Setup > Acquire Menu**.
- 2 In the Acquire Menu, click the **Acq Mode** softkey until the Averaging mode is selected.
- 3 Click the **#Avgs** softkey and enter the number of averages that best eliminates the noise from the displayed waveform. The number of acquisitions being averaged is displayed in the **# Avgs** softkey.

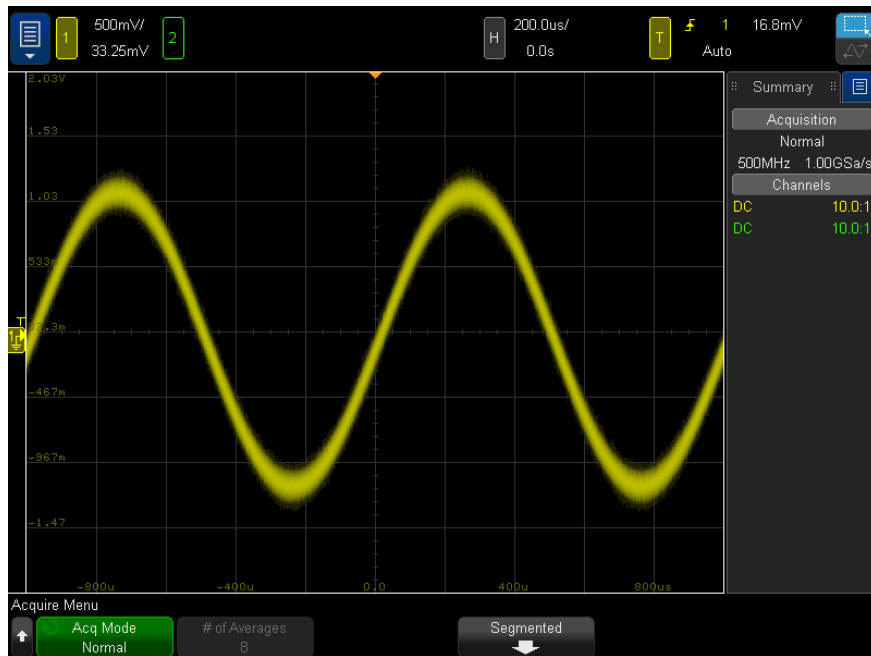

**Figure 31** Random noise on the displayed waveform

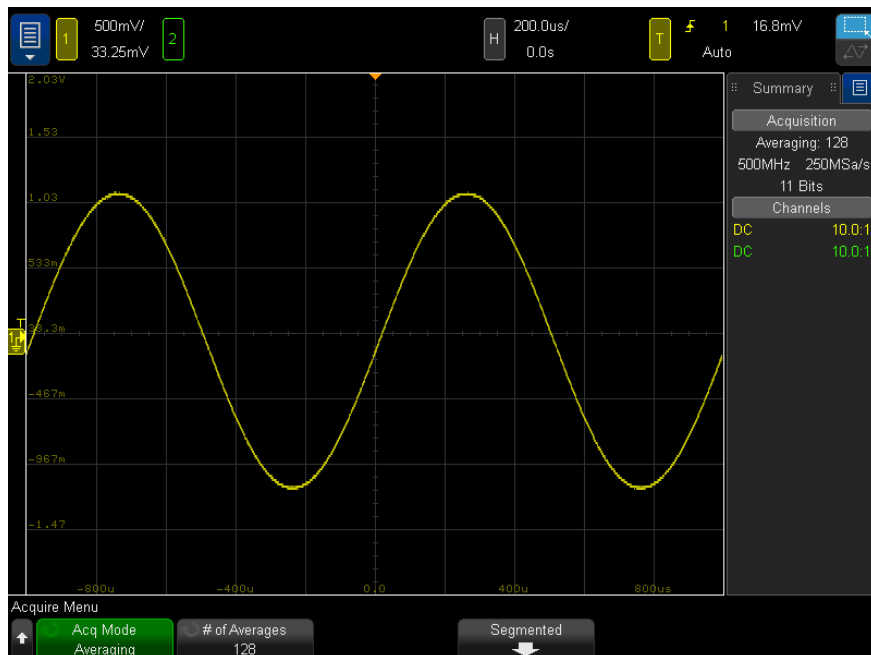

**Figure 32** 128 Averages used to reduce random noise

See Also • [Chapter 10](#), “Trigger Mode/Coupling,” starting on page 169

- **"Averaged Value"** on page 89

## High Resolution Acquisition Mode

In High Resolution mode, at slower time/div settings extra samples are averaged in order to reduce random noise, produce a smoother trace on the screen, and effectively increase vertical resolution.

High Resolution mode averages sequential sample points within the same acquisition. An extra bit of vertical resolution is produced for every factor of 2 averages. Random noise is reduced by  $\frac{1}{2}$  for every factor of 4 averages. The number of extra bits of vertical resolution is dependent on the time per division setting (sweep speed) of the oscilloscope.

The slower the time/div setting, the greater the number of samples that are averaged together for each display point.

High Resolution mode can be used on both single-shot and repetitive signals and it does not slow waveform update because the computation is done in the MegaZoom custom ASIC. High Resolution mode limits the oscilloscope's real-time bandwidth because it effectively acts like a low-pass filter.

Sweep speed	Bits of resolution
$\leq 1 \mu\text{s}/\text{div}$	8
$2 \mu\text{s}/\text{div}$	9
$5 \mu\text{s}/\text{div}$	10
$10 \mu\text{s}/\text{div}$	11
$\geq 20 \mu\text{s}/\text{div}$	12

## Realtime Sampling Option

With the P9241/42/43A oscilloscopes, realtime sampling is always on.

Realtime sampling specifies that the oscilloscope produce the waveform display from samples collected during one trigger event (that is, one acquisition).

Realtime sampling is good for capturing infrequent triggers, unstable triggers, or complex changing waveforms, such as eye diagrams.

When Realtime sampling is on:

- When less than 1000 samples can be collected in the time spanned by the screen, a sophisticated reconstruction filter is used to fill-in and enhance the waveform display.
- If you stop acquisitions and pan and zoom through the waveform using the Horizontal and Vertical controls, only the last trigger's acquisition will be displayed.

**See Also** • ["Realtime Sampling and Oscilloscope Bandwidth"](#) on page 190

## Realtime Sampling and Oscilloscope Bandwidth

To accurately reproduce a sampled waveform, the sample rate should be at least 2.5 times the highest frequency component of the waveform. If not, it is possible for the reconstructed waveform to be distorted or aliased. Aliasing is most commonly seen as jitter on fast edges.

The maximum sample rate for the P9241/42/43A oscilloscopes is 5 GSa/s for a single channel in a channel pair. Channels 1 and 2 constitute a channel pair. For example, the maximum sample rate of the 2-channel oscilloscope is 5 GSa/s when channels 1 or 2 are on.

Whenever both channels in a channel pair are on, the sample rate for all channels is halved. For example, when channels 1 and 2 are on, the maximum sample rate for all channels is 2.5 GSa/s.

When Realtime sampling is on, the bandwidth of the oscilloscope is limited because the bandwidth of the reconstruction filter is set to  $f_s/4$ . For example, a P9243A (1 GHz) oscilloscope with channels 1 and 2 on has a bandwidth of 625 MHz when Realtime sampling is on.

The sample rate is displayed in the sidebar Summary dialog.

## Acquiring to Segmented Memory

When capturing multiple infrequent trigger events it is advantageous to divide the oscilloscope's memory into segments. This lets you capture signal activity without capturing long periods of signal inactivity.

Each segment is complete with all analog channel and serial decode data.

When using segmented memory, use the Analyze Segments feature (see ["Measurements, Statistics, and Infinite Persistence with Segmented Memory"](#) on page 192) to show infinite persistence across all acquired segments. See also ["To set or clear persistence"](#) on page 114 for details.

- To acquire to segmented memory
- 1 Set up a trigger condition. (See [Chapter 9](#), "Triggers," starting on page 129 for details.)
  - 2 Choose **Main Menu > Setup > Acquire Menu**.
  - 3 Click the **Segmented** softkey.
  - 4 In the Segmented Memory Menu, click the **Segmented** softkey to enable segmented memory acquisitions.
  - 5 Click the **# of Segs** softkey and enter the number of segments into which you would like to divide the oscilloscope's memory.

Memory can be divided into as few as two segments and as many as 1000 segments.

- 6 Choose **Main Menu > Run/Stop** or **Main Menu > Single** to start the segmented memory acquisition.

The oscilloscope runs and fills a memory segment for each trigger event. When the oscilloscope is busy acquiring multiple segments, the progress is displayed on screen. The oscilloscope continues to trigger until memory is filled, then the oscilloscope stops.

If the signal you are measuring has more than about 1 s of inactivity, consider selecting the **Normal** trigger mode to prevent AutoTriggering. See ["To select the Auto or Normal trigger mode"](#) on page 170.

- See Also
- ["Navigating Segments"](#) on page 192
  - ["Measurements, Statistics, and Infinite Persistence with Segmented Memory"](#) on page 192
  - ["Segmented Memory Re-Arm Time"](#) on page 192
  - ["Saving Data from Segmented Memory"](#) on page 193

## Navigating Segments

- 1 Click the **Current Seg** softkey and enter the desired segment number. The segment is displayed along with a time tag indicating the time from the first trigger event.

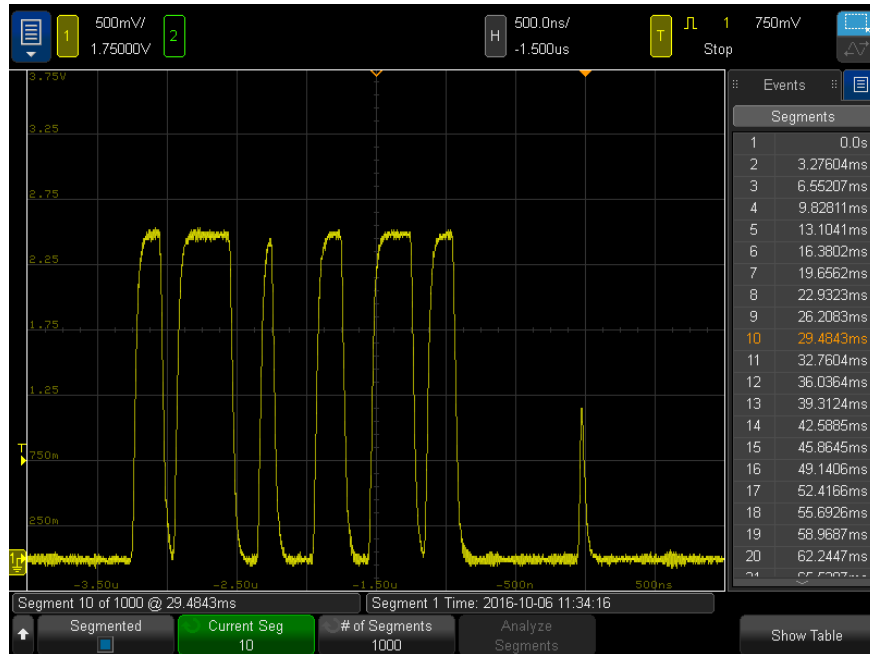

You can also navigate segments using the sidebar **Navigate** controls. See "[To navigate segments](#)" on page 50.

## Measurements, Statistics, and Infinite Persistence with Segmented Memory

To perform measurements and view statistical information, choose **Main Menu > Measure > Measurements** and set up your desired measurements (see [Chapter 13](#), "Measurements," starting on page 203). Then, click **Analyze Segments**. Statistical data will be accumulated for the measurements you have chosen.

The **Analyze Segments** softkey appears when the acquisition is stopped and the segmented memory feature is on or when the serial Lister is enabled.

You can also turn on infinite persistence (in the Display Menu) and click the **Analyze Segments** softkey to create an infinite persistence display.

## Segmented Memory Re-Arm Time

After each segment fills, the oscilloscope re-arms and is ready to trigger in about 1  $\mu$ s.



Remember though, for example: if the horizontal time per division control is set to  $5\ \mu\text{s}/\text{div}$ , and the Time Reference is set to **Center**, it will take at least  $50\ \mu\text{s}$  to fill all ten divisions and re-arm. (That is  $25\ \mu\text{s}$  to capture pre-trigger data and  $25\ \mu\text{s}$  to capture post-trigger data.)

## Saving Data from Segmented Memory

You can save either the currently displayed segment (**Save Segment - Current**), or all segments (**Save Segment - All**) in the following data formats: CSV, ASCII XY, and BIN.

Be sure to set the Length control to capture enough points to accurately represent the captured data. When the oscilloscope is busy saving multiple segments, progress is displayed in the upper right area of the display.

For more information, see ["To save CSV, ASCII XY, or BIN data files"](#) on page 284.



# 12 Cursors

To make cursor measurements / 197

Cursor Examples / 199

Cursors are horizontal and vertical markers that indicate X-axis values and Y-axis values on a selected waveform source. You can use cursors to make custom voltage, time, phase, or ratio measurements on oscilloscope signals.

Cursor information is displayed in the right-side information area.

Cursors are not always limited to the visible display. If you set a cursor, then pan and zoom the waveform until the cursor is off screen, its value will not be changed. It will still be there when you return to its original location.

**X Cursors** X cursors are vertical dashed lines that adjust horizontally and can be used to measure time (s), frequency (1/s), phase (°), and ratio (%).

The X1 cursor is the short-dashed vertical line, and the X2 cursor is the long-dashed vertical line.

When used with the FFT math function as a source, the X cursors indicate frequency.

In XY horizontal mode, the X cursors display channel 1 values (Volts or Amps).

The X1 and X2 cursor values for the selected waveform source are displayed in the softkey menu area.

The difference between X1 and X2 ( $\Delta X$ ) and  $1/\Delta X$  are displayed in the Cursors box in the right-side information area.

**Y Cursors** Y cursors are horizontal dashed lines that adjust vertically and can be used to measure Volts or Amps, dependent on the channel **Probe Units** setting, or they can measure ratios (%). When math functions are used as a source, the measurement units correspond to that math function.

The Y1 cursor is the short-dashed horizontal line and the Y2 cursor is the long-dashed horizontal line.

The Y cursors adjust vertically and typically indicate values relative to the waveform's ground point, except math FFT where the values are relative to 0 dB.

In XY horizontal mode, the Y cursors display channel 2 values (Volts or Amps).

When active, the Y1 and Y2 cursor values for the selected waveform source are displayed in the softkey menu area.

The difference between Y1 and Y2 ( $\Delta Y$ ) is displayed in the Cursors box in the right-side information area.

## To make cursor measurements

- 1 Connect a signal to the oscilloscope and obtain a stable display.
- 2 Choose **Main Menu > Measure > Cursors**.

The Cursors box in the right-side information area appears, indicating that cursors are "on". (Choose **Main Menu > Measure > Cursors** again when you want to turn cursors off.)

- 3 In the Cursors Menu, click **Mode**; then, select the desired mode:
  - **Manual** –  $\Delta X$ ,  $1/\Delta X$ , and  $\Delta Y$  values are displayed.  $\Delta X$  is the difference between the X1 and X2 cursors and  $\Delta Y$  is the difference between the Y1 and Y2 cursors.



- **Track Waveform** – As you move a marker horizontally, the vertical amplitude of the waveform is tracked and measured. The time and voltage positions are shown for the markers. The vertical (Y) and horizontal (X) differences between the markers are shown as  $\Delta X$  and  $\Delta Y$  values.
- **Measure** – When measurements are displayed, this mode shows the cursor locations used to make the measurement. When you add a measurement, it becomes the one that cursors are displayed for. You can use the **Measurement** softkey or click in the Meas sidebar dialog to select the measurement whose cursor locations are displayed.
- **Binary** – Logic levels of displayed waveforms at the current X1 and X2 cursor positions are displayed in the Cursor sidebar dialog in binary. The display is color coded to match the color of the related channel's waveform.



- **Hex** – Logic levels of displayed waveforms at the current X1 and X2 cursor positions are displayed in the Cursor sidebar dialog in hexadecimal.



**Manual** and **Track Waveform** modes can be used on waveforms that are displayed on the analog input channels (including math functions).

In **Hex** and **Binary** modes, a level can be displayed as 1 (higher than trigger level), 0 (lower than trigger level), indeterminate state (-), or X (don't care).

In **Binary** mode, X is displayed if the channel is turned off.

In **Hex** mode, the channel is interpreted as 0 if turned off.

- 4 Click **Source** (or **X1 Source**, **X2 Source** in the **Track Waveform** mode); then, select the input source for cursor values.
- 5 Click the **Cursors** softkey; then, select the cursor(s) to be adjusted.

The **X1 X2 linked** and **Y1 Y2 linked** selections let you adjust both cursors at the same time, while the delta value remains the same. This can be useful, for example, for checking pulse width variations in a pulse train.

The currently selected cursor(s) display brighter than the other cursors.

When individual cursors are selected, click the softkey to disable or reenble the cursor display.

- 6 To change the cursor units, click the **Units** softkey.

In the Cursor Units Menu:



You can click the **X Units** softkey to select:

- **Seconds (s)**.
- **Hz (1/s)**.
- **Phase (°)** – when selected, use the **Use X Cursors** softkey to set the current X1 location as 0 degrees and the current X2 location as 360 degrees.
- **Ratio (%)** – when selected, use the **Use X Cursors** softkey to set the current X1 location as 0% and the current X2 location as 100%.

You can click the **Y Units** softkey to select:

- **Base** – the same units used for the source waveform.
- **Ratio (%)** – when selected, use the **Use Y Cursors** softkey to set the current Y1 location as 0% and the current Y2 location as 100%.

For phase or ratio units, once the 0 and 360 degree or 0 and 100% locations are set, adjusting cursors will display measurements relative to the set locations.

- 7 Drag the cursor name handles to position them. See "**Drag Cursors**" on page 29.

## Cursor Examples

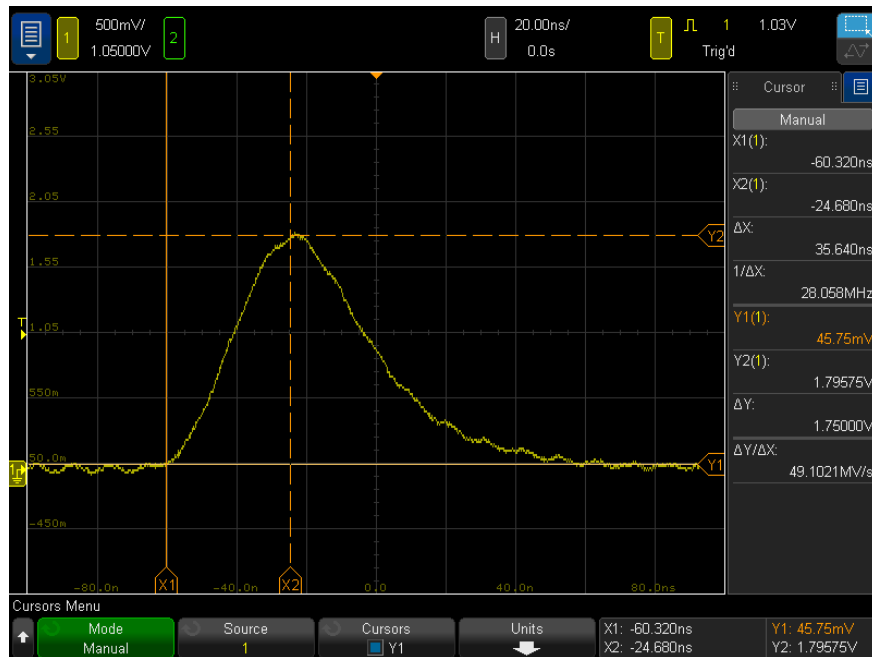

Figure 33 Cursors used to measure pulse widths other than middle threshold points

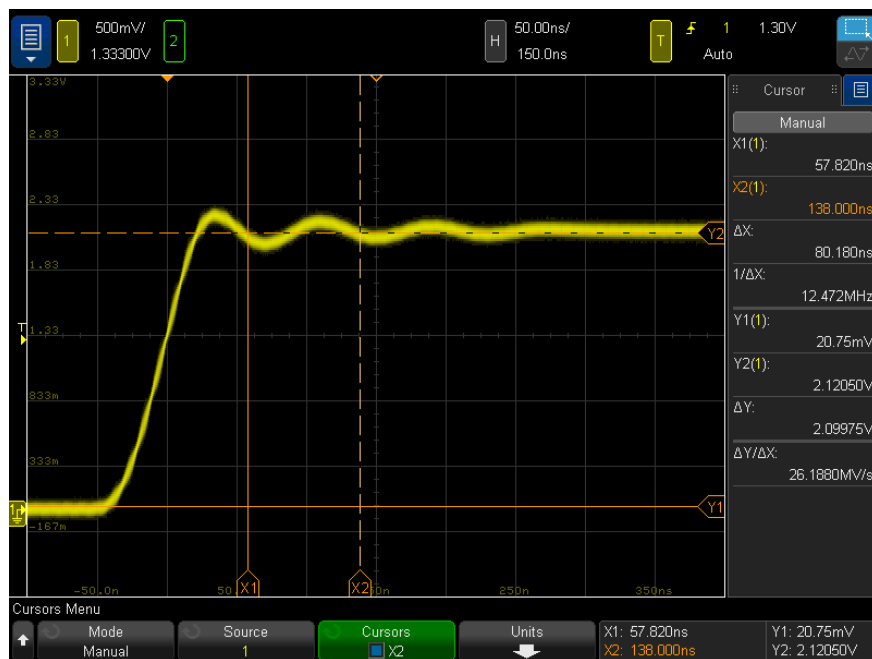
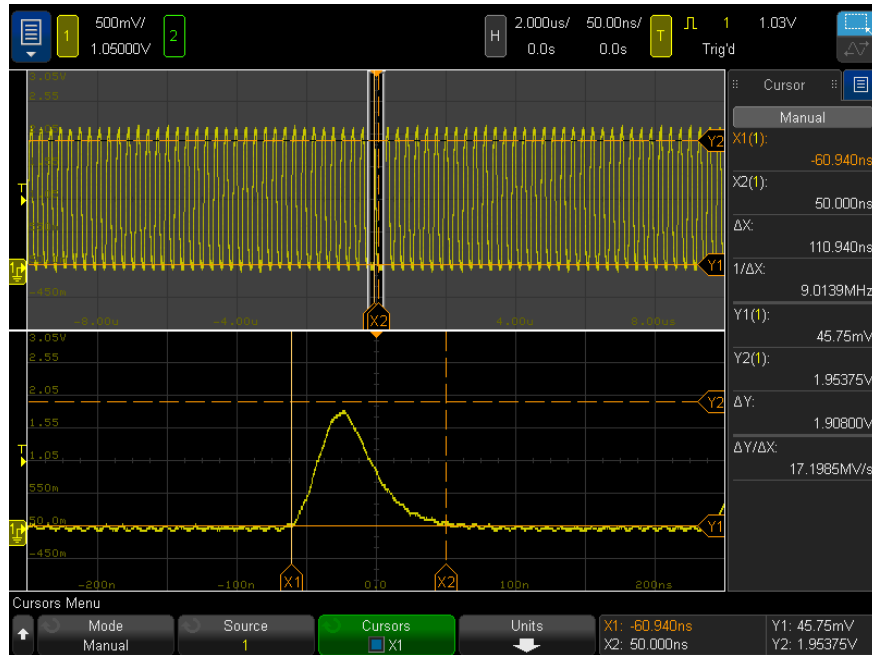

Figure 34 Cursors measure frequency of pulse ringing

Expand the display with Zoom mode, then characterize the event of interest with the cursors.



**Figure 35** Cursors track Zoom window

Put the **X1** cursor on one side of a pulse and the **X2** cursor on the other side of the pulse.



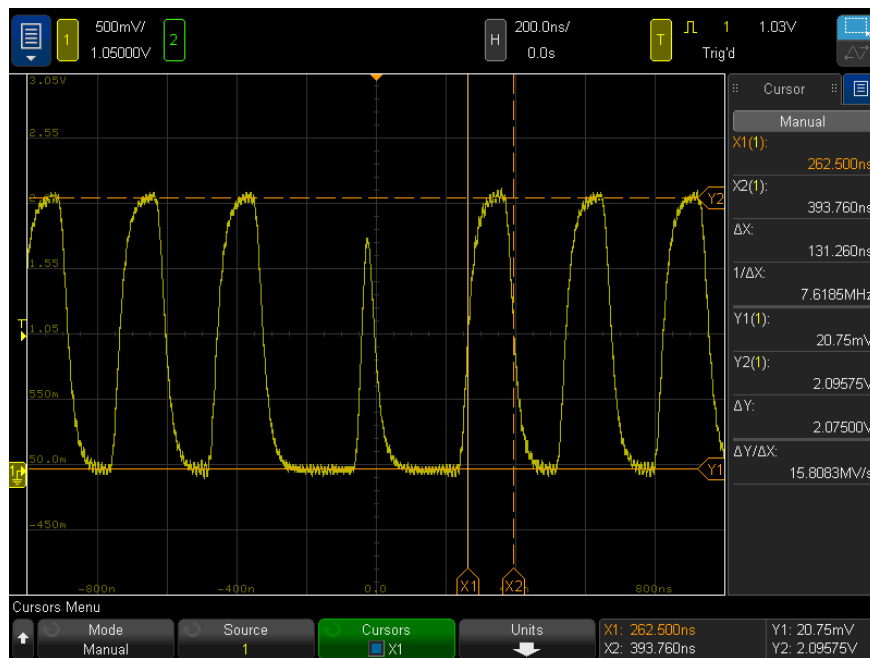

**Figure 36** Measuring pulse width with cursors

Click the **X1 X2 linked** softkey and move the cursors together to check for pulse width variations in a pulse train.

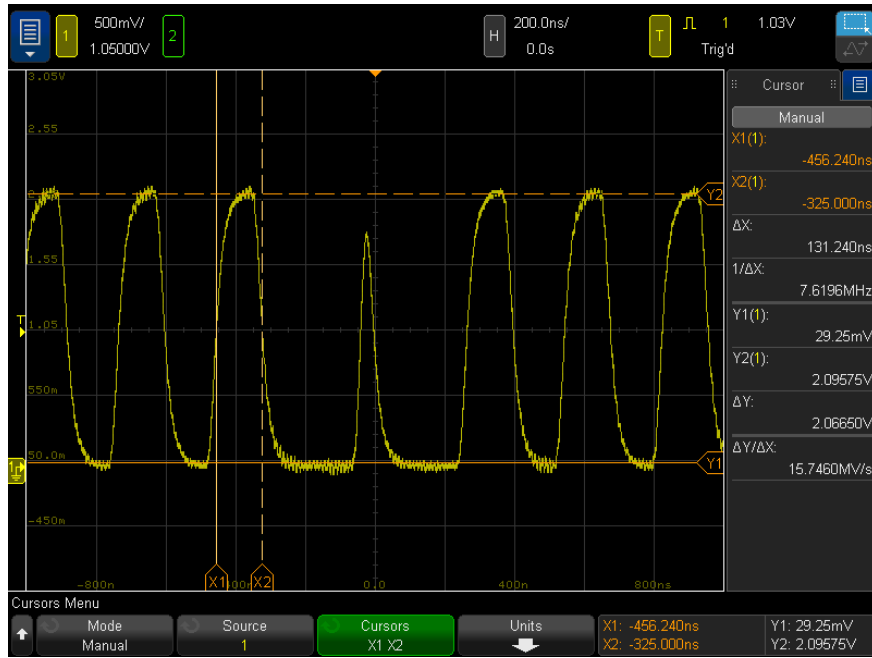

**Figure 37** Moving the cursors together to check pulse width variations

# 13 Measurements

- To make automatic measurements / 205
- To edit measurements / 207
- Measurements Summary / 208
- Voltage Measurements / 211
- Time Measurements / 218
- Count Measurements / 225
- Mixed Measurements / 227
- FFT Analysis Measurements / 228
- Measurement Thresholds / 230
- Measurement Window / 232
- Measurement Statistics / 233

The **Main Menu > Measure > Measurements** menu lets you make automatic measurements on waveforms. Some measurements can only be made on analog input channels.

The results of the last eight selected measurements are displayed in the Measurements list dialog (which can be selected from the right-hand sidebar menu – see "[Select Sidebar Information or Controls](#)" on page 27 and "[Undock Sidebar Dialog Boxes by Dragging](#)" on page 28).

When you add a measurement, it appears at the bottom of the Measurements list dialog box, and cursors that show the portion of the waveform being measured are automatically displayed. You can change the measurement for which cursors are displayed by clicking the measurement in the list and choosing **Track With Cursors** in the popup menu or by selecting the measurement in the Cursors Menu.

**NOTE****Post Acquisition Processing**

In addition to changing display parameters after the acquisition, you can perform all of the measurements and math functions after the acquisition. Measurements and math functions will be recalculated as you pan and zoom and turn channels on and off. As you adjust the horizontal and vertical scale of a waveform, you affect the resolution of the display. Because measurements and math functions are performed on displayed data, you affect the resolution of functions and measurements.

---

## To make automatic measurements

- 1 Choose **Main Menu > Measure > Measurements** to display the Measurement Menu.



- 2 Click **Add Meas** to open the Add Measurements Menu.

- 3 If the **Parameter** softkey is available, select **Source**.

The **Parameter** softkey is available when there are multiple settings for a measurements.

- 4 Click the **Source** softkey to select the channel, running math function, or reference waveform to be measured.

Only channels, math functions, or reference waveforms that are displayed are available for measurements.

### NOTE

If a portion of the waveform required for a measurement is not displayed or does not display enough resolution to make the measurement (approximately 4% of full scale), the result will display "No Edges", "Clipped", "Low Signal" (not enough amplitude), "< value", or "> value", or a similar message to indicate that the measurement may not be reliable.

- 5 Click the **Type:** softkey; then, select a measurement to be made.



You can click the "+" in the Measurements sidebar dialog to open the measurement type menu. See also "[Click Softkeys and Menus On the Screen](#)" on page 30.

For more information on the types of measurements, see "[Measurements Summary](#)" on page 208.

- 6 Click the **Add Measurement** softkey to display the measurement.

Cursors are turned on to show the portion of the waveform being measured for the most recently added measurement (bottom-most on the display). To view the cursors for a previously added measurement (but not the last one), add the measurement again.

By default, measurement statistics are displayed. See "[Measurement Statistics](#)" on page 233.

- 7 To turn off measurements, choose **Main Menu > Measure > Measurements** again.

Measurements are erased from the display.

- 8 To stop making one or more measurements, click the **Clear Meas** softkey in the Measurement Menu and select the measurement to clear, or click **Clear All**.



After all measurements have been cleared, choosing **Main Menu > Measure > Measurements** again, the default measurements will be Frequency and Peak-Peak.

## To edit measurements

When added measurements have parameters that can be edited (like the Delay, Phase, Occupied Bandwidth, ACPR, or THD measurements), you can edit the parameters of those measurements.

- 1 Choose **Main Menu > Measure > Measurements** to display the Measurement Menu.
- 2 Click **Edit Meas** to open the Edit Measurements Menu.
- 3 Click the **Parameter** softkey to select the parameter(s) you would like to edit; then, use the remaining softkeys to edit that parameter.

## Measurements Summary

The automatic measurements provided by the oscilloscope are listed in the following table. All measurements are available for analog channel waveforms. All measurements except Counter are available for reference waveforms and math waveforms other than FFT. A limited set of measurements is available for math FFT waveforms (as described in the following table).

**Table 4** Measurements Summary

Measurement	Valid for Math FFT*	Notes
"Snapshot All" on page 209		
"Adjacent Channel Power Ratio (ACPR)" on page 228	Yes	Measurement is valid for FFT Magnitude math waveforms only.
"Amplitude" on page 212		
"Area" on page 227		
"Average" on page 215	Yes, Full Screen	
"Base" on page 213		
"Bit Rate" on page 221		
"Burst Width" on page 220		
"Channel Power" on page 228	Yes	Measurement is valid for FFT Magnitude math waveforms only.
"Counter" on page 219		Not valid for math waveforms.
"Delay" on page 221		Measures between two sources. Click <b>Settings</b> to specify the second source.
"Duty Cycle" on page 220		
"Fall Time" on page 221		
"Frequency" on page 219		
"Maximum" on page 211	Yes	
"Minimum" on page 212	Yes	
"Rising Edge Count" on page 225		
"Falling Edges Count" on page 226		
"Positive Pulse Count" on page 225		

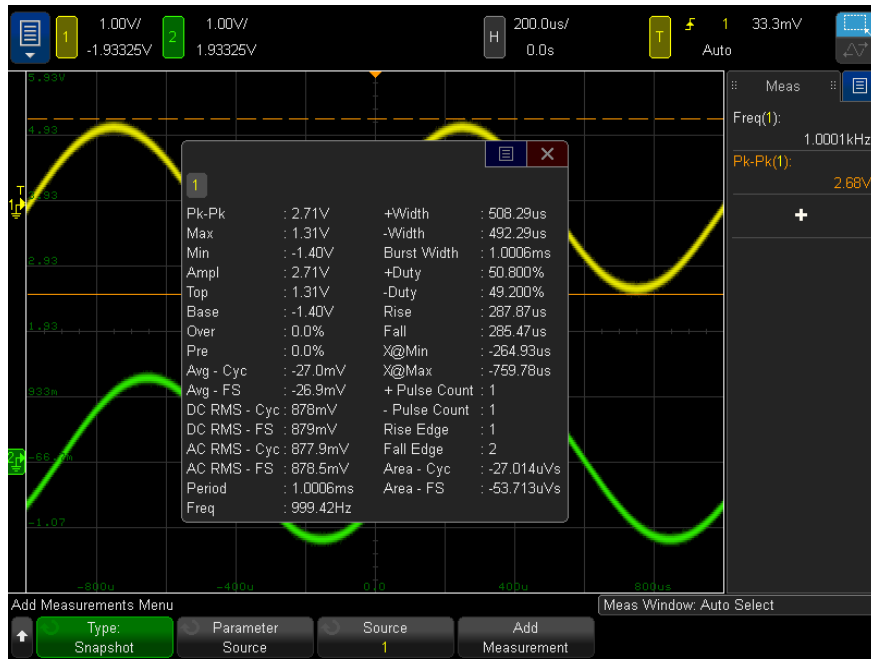

**Table 4** Measurements Summary (continued)

Measurement	Valid for Math FFT*	Notes
"Negative Pulse Count" on page 225		
"Occupied Bandwidth" on page 228	Yes	Measurement is valid for FFT Magnitude math waveforms only.
"Overshoot" on page 213		
"Peak-Peak" on page 211	Yes	
"Period" on page 218		
"Phase" on page 222		Measures between two sources. Click <b>Settings</b> to specify the second source.
"Preshoot" on page 214		
"Ratio" on page 217		Measures between two sources. Click <b>Settings</b> to specify the second source.
"Rise Time" on page 221		
"DC RMS" on page 215		
"AC RMS" on page 215		
"Top" on page 212		
"Total Harmonic Distortion (THD)" on page 229	Yes	Measurement is valid for FFT Magnitude math waveforms only.
" + Width" on page 220		
" - Width" on page 220		
"X at Max Y" on page 224	Yes	The resultant units are in Hertz.
"X at Min Y" on page 223	Yes	The resultant units are in Hertz.
* Use the cursors to make other measurements on FFT.		

## Snapshot All

The Snapshot All measurement type displays a popup containing a snapshot of all the single waveform measurements.



You can also configure the **Main Menu > Quick Action** menu item to display the Snapshot All popup. See "[Configuring the Quick Action Menu Item](#)" on page 304.

## Voltage Measurements

The following figure shows the voltage measurement points.

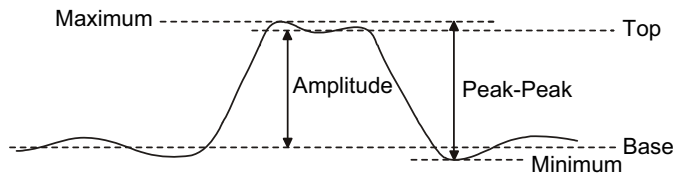

Measurement units for each input channel can be set to Volts or Amps using the channel **Probe Units** softkey. See ["To specify the channel units"](#) on page 61.

The units of math waveforms are described in ["Units for Math Waveforms"](#) on page 69.

- ["Peak-Peak"](#) on page 211
- ["Maximum"](#) on page 211
- ["Minimum"](#) on page 212
- ["Amplitude"](#) on page 212
- ["Top"](#) on page 212
- ["Base"](#) on page 213
- ["Overshoot"](#) on page 213
- ["Preshoot"](#) on page 214
- ["Average"](#) on page 215
- ["DC RMS"](#) on page 215
- ["AC RMS"](#) on page 215
- ["Ratio"](#) on page 217

### Peak-Peak

The peak-to-peak value is the difference between Maximum and Minimum values. The Y cursors show the values being measured.

### Maximum

Maximum is the highest value in the waveform display. The Y cursor shows the value being measured.

## Minimum

Minimum is the lowest value in the waveform display. The Y cursor shows the value being measured.

## Amplitude

The Amplitude of a waveform is the difference between its Top and Base values. The Y cursors show the values being measured.

## Top

The Top of a waveform is the mode (most common value) of the upper part of the waveform, or if the mode is not well defined, the top is the same as Maximum. The Y cursor shows the value being measured.

See Also • ["To isolate a pulse for Top measurement"](#) on page 212

### To isolate a pulse for Top measurement

The following figure shows how to use Zoom mode to isolate a pulse for a **Top** measurement.

You may need to change the measurement window setting so that the measurement is made in the lower, Zoom window. See ["Measurement Window"](#) on page 232.



**Figure 38** Isolating area for Top measurement

## Base

The Base of a waveform is the mode (most common value) of the lower part of the waveform, or if the mode is not well defined, the base is the same as Minimum. The Y cursor shows the value being measured.

## Overshoot

Overshoot is distortion that follows a major edge transition expressed as a percentage of Amplitude. The X cursors show which edge is being measured (edge closest to the trigger reference point).

$$\text{Rising edge overshoot} = \frac{\text{local Maximum} - \text{D Top}}{\text{Amplitude}} \times 100$$

$$\text{Falling edge overshoot} = \frac{\text{Base} - \text{D local Minimum}}{\text{Amplitude}} \times 100$$

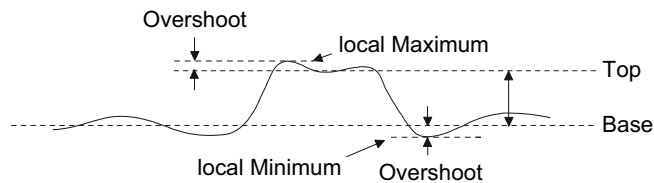

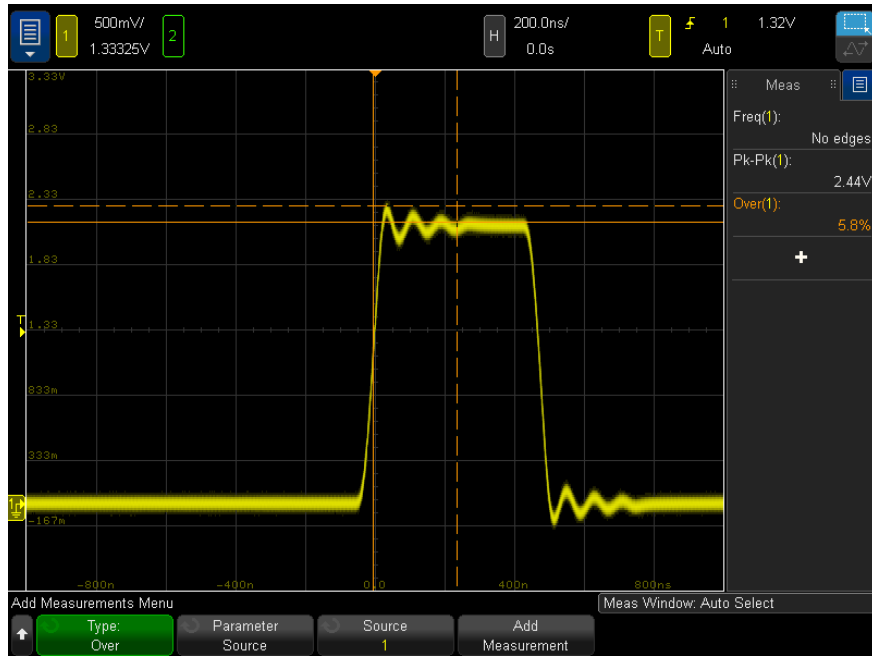

**Figure 39** Automatic Overshoot measurement

### Preshoot

Preshoot is distortion that precedes a major edge transition expressed as a percentage of Amplitude. The X cursors show which edge is being measured (edge closest to the trigger reference point).

$$\text{Rising edge preshoot} = \frac{\text{local Maximum} - \text{D Top}}{\text{Amplitude}} \times 100$$

$$\text{Falling edge preshoot} = \frac{\text{Base} - \text{D local Minimum}}{\text{Amplitude}} \times 100$$

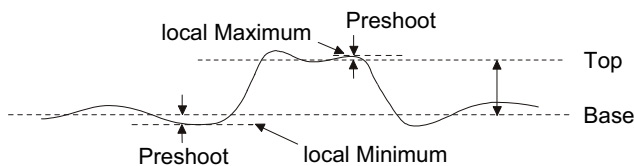

## Average

Average is the sum of the levels of the waveform samples divided by the number of samples.

$$\text{Average} = \frac{\sum x_i}{n}$$

Where  $x_i$  = value at  $i$ th point being measured,  $n$  = number of points in measurement interval.

The Full Screen measurement interval variation measures the value on all displayed data points.

The N Cycles measurement interval variation measures the value on an integral number of periods of the displayed signal. If less than three edges are present, the measurement shows "No edges".

The X cursors show what interval of the waveform is being measured.

## DC RMS

DC RMS is the root-mean-square value of the waveform over one or more full periods.

$$\text{RMS (dc)} = \sqrt{\frac{\sum_{i=1}^n x_i^2}{n}}$$

Where  $x_i$  = value at  $i$ th point being measured,  $n$  = number of points in measurement interval.

The Full Screen measurement interval variation measures the value on all displayed data points.

The N Cycles measurement interval variation measures the value on an integral number of periods of the displayed signal. If less than three edges are present, the measurement shows "No edges".

The X cursors show the interval of the waveform being measured.

## AC RMS

AC RMS is the root-mean-square value of the waveform, with the DC component removed. It is useful, for example, for measuring power supply noise.

The N Cycles measurement interval measures the value on an integral number of periods of the displayed signal. If less than three edges are present, the measurement shows "No edges".

The X cursors show the interval of the waveform being measured.

The Full Screen (Std Deviation) measurement interval variation is an RMS measurement across the full screen with the DC component removed. It shows the standard deviation of the displayed voltage values.

The standard deviation of a measurement is the amount that a measurement varies from the mean value. The Mean value of a measurement is the statistical average of the measurement.

The following figure graphically shows the mean and standard deviation. Standard deviation is represented by the Greek letter sigma:  $\sigma$ . For a Gaussian distribution, two sigma ( $\pm 1\sigma$ ) from the mean, is where 68.3 percent of the measurement results reside. Six sigma ( $\pm 3\sigma$ ) from is where 99.7 percent of the measurement results reside.

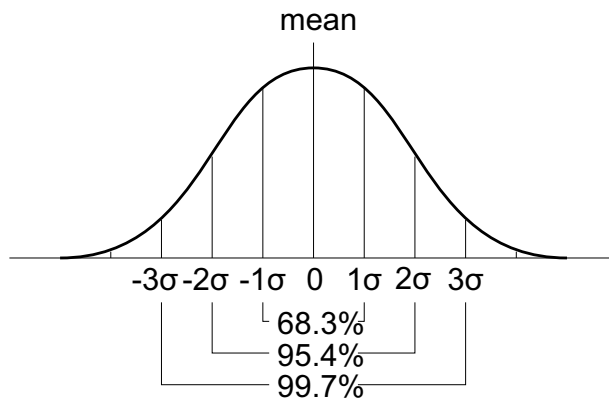

The mean is calculated as follows:

$$\bar{x} = \frac{\sum_{i=1}^N x_i}{N}$$

where:

- $x$  = the mean.
- $N$  = the number of measurements taken.
- $x_i$  = the  $i$ th measurement result.

The standard deviation is calculated as follows:

$$\sigma = \sqrt{\frac{\sum_{i=1}^N (x_i - \bar{x})^2}{N}}$$

where:



- $\sigma$  = the standard deviation.
- $N$  = the number of measurements taken.
- $x_i$  = the  $i$ th measurement result.
- $\bar{x}$  = the mean.

## Ratio

The Ratio measurement displays the ratio of the AC RMS voltages of two sources, expressed in dB. Press the **Settings** softkey to select the source channels for the measurement.

## Time Measurements

The following figure shows time measurement points.

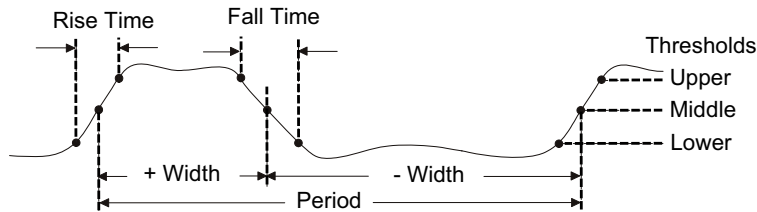

The default lower, middle, and upper measurement thresholds are 10%, 50%, and 90% between Top and Base values. See **"Measurement Thresholds"** on page 230 for other percentage threshold and absolute value threshold settings.

- **"Period"** on page 218
- **"Frequency"** on page 219
- **"Counter"** on page 219
- **"+ Width"** on page 220
- **"- Width"** on page 220
- **"Burst Width"** on page 220
- **"Duty Cycle"** on page 220
- **"Bit Rate"** on page 221
- **"Rise Time"** on page 221
- **"Fall Time"** on page 221
- **"Delay"** on page 221
- **"Phase"** on page 222
- **"X at Min Y"** on page 223
- **"X at Max Y"** on page 224

### Period

Period is the time period of the complete waveform cycle. The time is measured between the middle threshold points of two consecutive, like-polarity edges. A middle threshold crossing must also travel through the lower and upper threshold levels which eliminates runt pulses. The X cursors show what portion of the waveform is being measured. The Y cursor shows the middle threshold point.

## Frequency

Frequency is defined as  $1/\text{Period}$ . Period is defined as the time between the middle threshold crossings of two consecutive, like-polarity edges. A middle threshold crossing must also travel through the lower and upper threshold levels which eliminates runt pulses. The X cursors show what portion of the waveform is being measured. The Y cursor shows the middle threshold point.

See Also • ["To isolate an event for frequency measurement"](#) on page 219

### To isolate an event for frequency measurement

The following figure shows how to use Zoom mode to isolate an event for a frequency measurement.

You may need to change the measurement window setting so that the measurement is made in the lower, Zoom window. See ["Measurement Window"](#) on page 232.

If the waveform is clipped, it may not be possible to make the measurement.

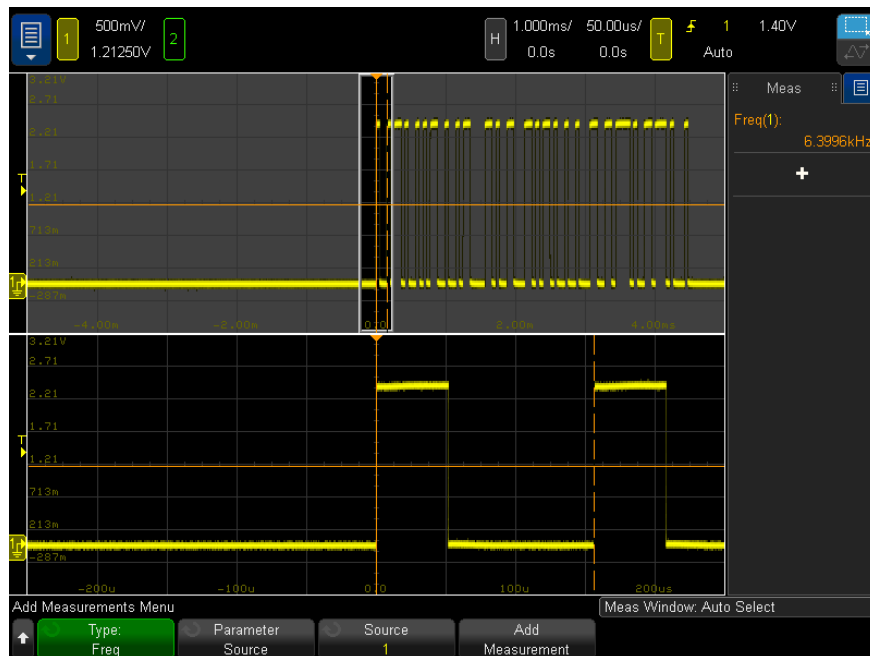

**Figure 40** Isolating an event for Frequency measurement

## Counter

The P9241/42/43A oscilloscopes have an integrated hardware frequency counter which counts the number of cycles that occur within a period of time (known as the gate time) to measure the frequency of a signal.

The gate time is the horizontal range of the oscilloscope but is limited to  $\geq 0.1$  s and  $\leq 10$  s. Unlike other measurements, the Zoom horizontal timebase window does not gate the Counter measurement.

The Counter measurement can measure frequencies up to the bandwidth of the oscilloscope. The minimum frequency supported is  $2.0 / \text{gateTime}$ .

The hardware counter uses the trigger comparator output. Therefore, the counted channel's trigger level (or threshold for digital channels) must be set correctly.

Analog and digital channels can be selected as the source.

Only one Counter measurement can be displayed at a time.

**See Also** · **"Counter"** on page 252

### + Width

**+ Width** is the time from the middle threshold of the rising edge to the middle threshold of the next falling edge. The X cursors show the pulse being measured. The Y cursor shows the middle threshold point.

### – Width

**– Width** is the time from the middle threshold of the falling edge to the middle threshold of the next rising edge. The X cursors show the pulse being measured. The Y cursor shows the middle threshold point.

### Burst Width

The Burst Width measurement is the time from the first edge to the last edge on screen.

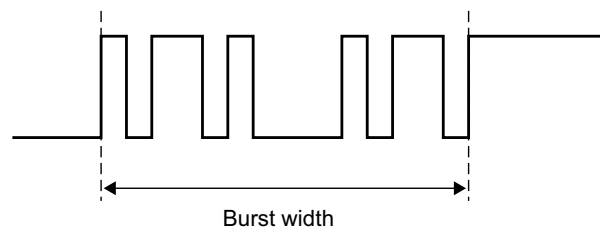

### Duty Cycle

The duty cycle of a repetitive pulse train is the ratio of the pulse width to the period, expressed as a percentage. The X cursors show the time period being measured. The Y cursor shows the middle threshold point.

$$+ \text{Duty cycle} = \frac{+ \text{Width}}{\text{Period}} \times 100 \quad - \text{Duty cycle} = \frac{- \text{Width}}{\text{Period}} \times 100$$

## Bit Rate

The bit rate measurement measures all positive and negative pulse widths on the waveform, takes the minimum value found of either width type and inverts that minimum width to give a value in Hertz.

## Rise Time

The rise time of a signal is the time difference between the crossing of the lower threshold and the crossing of the upper threshold for a positive-going edge. The X cursor shows the edge being measured. For maximum measurement accuracy, set the horizontal time/div as fast as possible while leaving the complete rising edge of the waveform on the display. The Y cursors show the lower and upper threshold points.

## Fall Time

The fall time of a signal is the time difference between the crossing of the upper threshold and the crossing of the lower threshold for a negative-going edge. The X cursor shows the edge being measured. For maximum measurement accuracy, set the horizontal time/div as fast as possible while leaving the complete falling edge of the waveform on the display. The Y cursors show the lower and upper threshold points.

## Delay

Delay measures the time difference from the specified source 1 edge that is closest to the center of the screen and the nearest specified source 2 edge using the middle threshold points on the waveforms.

Negative delay values indicate that the selected edge of source 1 occurred after the selected edge of source 2.

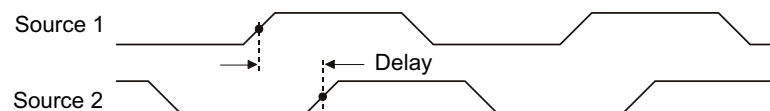

- 1 Choose **Main Menu > Measure > Measurements**.
- 2 In the Measurement Menu, click **Add Meas**.
- 3 In the Add Measurements Menu, click the **Type:** softkey; then, select **Delay**.
- 4 Click the **Parameter** softkey; then, select and specify the following parameters:

- **Source 1, Source 2** – waveform source.
- **Source 1 Slope, Source 2 Slope** – rising edge or falling edge.
- **Source 1 Edge #, Source 2 Edge #** – edge number for the selected source.

When **Auto** is selected for the **Source 1 Edge #**, the edge closest to the timebase reference point is used. **Auto** is also automatically selected for the **Source 2 Edge #**, and cannot be changed. In this case, the source 2 edge closest to the source 1 edge is used.

When edge numbers are selected, edges are counted from the left side of the display for both sources.

- 5 Click the **Add Measurement** softkey to make the measurement.

The example below shows a delay measurement between the rising edge of channel 1 and the rising edge of channel 2.

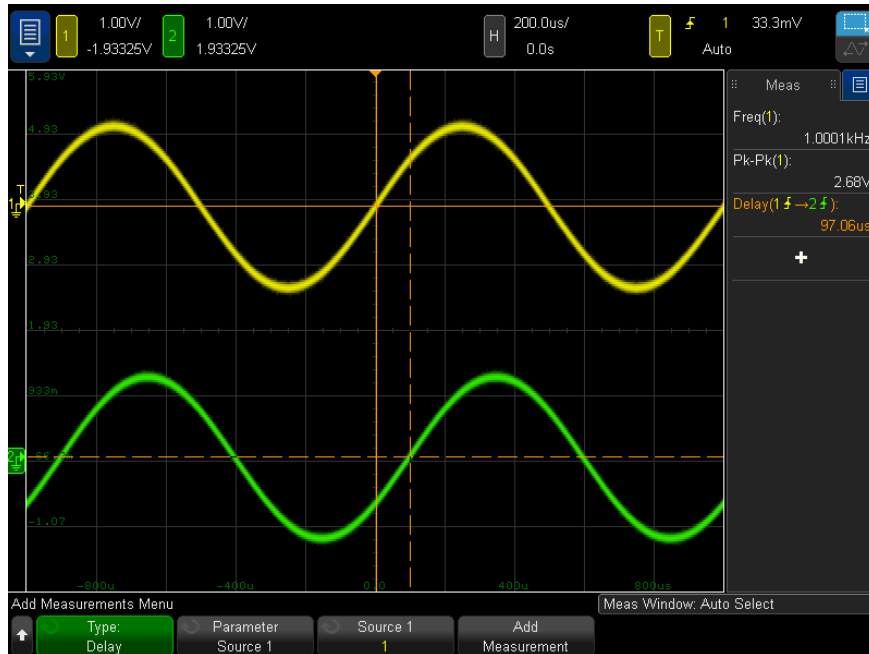

## Phase

Phase is the calculated phase shift from source 1 to source 2, expressed in degrees. Negative phase shift values indicate that the rising edge of source 1 occurred after the rising edge of source 2.

$$\text{Phase} = \frac{\text{Delay}}{\text{Source 1 Period}} \times 360$$

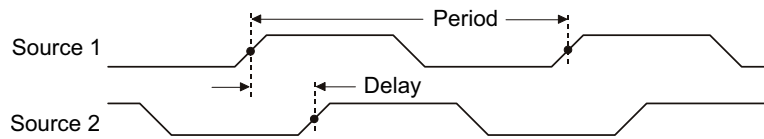

- 1 Choose **Main Menu > Measure > Measurements**.
- 2 In the Measurement Menu, click **Add Meas**.
- 3 In the Add Measurements Menu, click the **Type:** softkey; then, select **Phase**.
- 4 Click the **Parameter** softkey; then, select and specify the following parameters:
  - **Source 1**
  - **Source 2**

The default Phase settings measure from channel 1 to channel 2.

- 5 Click the **Add Measurement** softkey to make the measurement.

The example below shows a phase measurement between the channel 1 and channel 2.

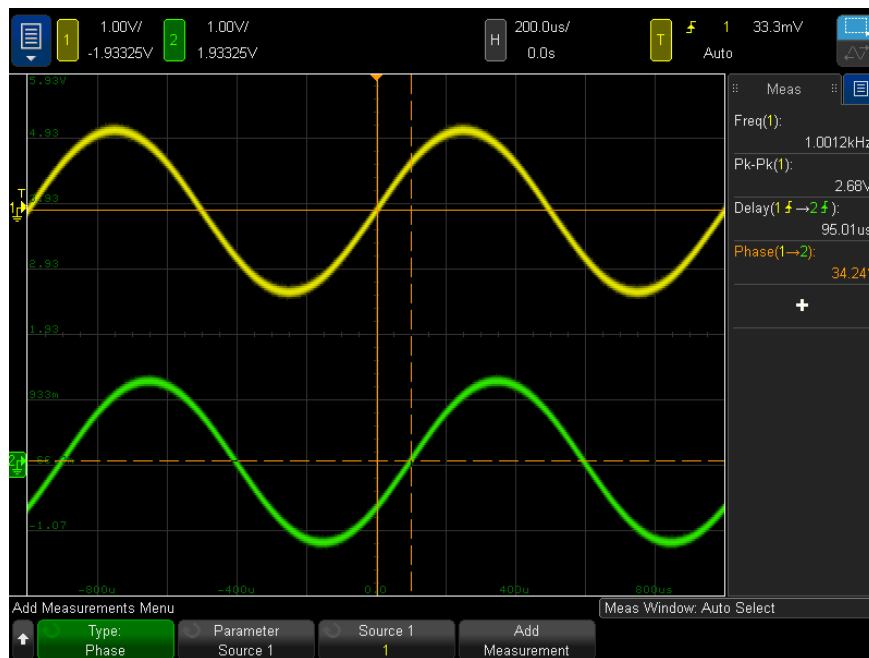

## X at Min Y

X at Min Y is the X axis value (usually time) at the first displayed occurrence of the waveform Minimum, starting from the left-side of the display. For periodic signals, the position of the minimum may vary throughout the waveform. The X cursor shows where the current X at Min Y value is being measured.

## X at Max Y

X at Max Y is the X axis value (usually time) at the first displayed occurrence of the waveform Maximum, starting from the left-side of the display. For periodic signals, the position of the maximum may vary throughout the waveform. The X cursor shows where the current X at Max Y value is being measured.

**See Also** · ["To measure the peak of an FFT"](#) on page 224

### To measure the peak of an FFT

- 1 Select **FFT** as the Operator in the Waveform Math Menu.
- 2 Choose **Math N** as the source in the Add Measurements Menu.
- 3 Choose **Maximum** and **X at Max Y** measurements.

**Maximum** units are in dB and **X at Max Y** units are in Hertz for FFT.



## Count Measurements

- **"Positive Pulse Count"** on page 225
- **"Negative Pulse Count"** on page 225
- **"Rising Edge Count"** on page 225
- **"Falling Edges Count"** on page 226

### Positive Pulse Count

The **Positive Pulse Count** measurement is a pulse count for the selected waveform source.

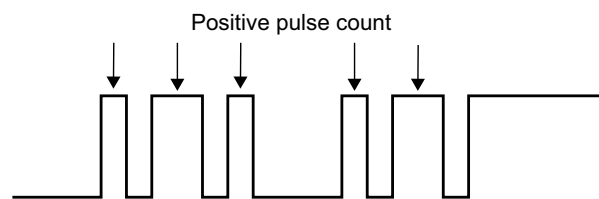

This measurement is available for analog channels.

### Negative Pulse Count

The **Negative Pulse Count** measurement is a pulse count for the selected waveform source.

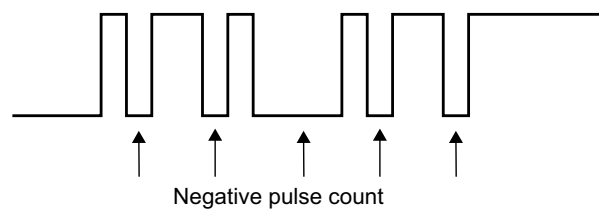

This measurement is available for analog channels.

### Rising Edge Count

The **Rising Edge Count** measurement is an edge count for the selected waveform source.

This measurement is available for analog channels.

## Falling Edges Count

The **Falling Edges Count** measurement is an edge count for the selected waveform source.

This measurement is available for analog channels.

## Mixed Measurements

- "Area" on page 227

### Area

Area measures the area between the waveform and the ground level. Area below the ground level is subtracted from area above the ground level.

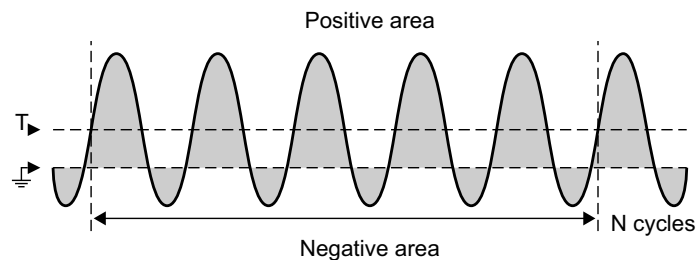

The Full Screen measurement interval variation measures the value on all displayed data points.

The N Cycles measurement interval variation measures the value on an integral number of periods of the displayed signal. If less than three edges are present, the measurement shows "No edges".

The X cursors show what interval of the waveform is being measured.

## FFT Analysis Measurements

- "**Channel Power**" on page 228
- "**Occupied Band width**" on page 228
- "**Adjacent Channel Power Ratio (ACPR)**" on page 228
- "**Total Harmonic Distortion (THD)**" on page 229

### Channel Power

**Channel Power** measures the spectral power across a frequency range.

The center frequency used in the measurement is the one defined for the FFT function, and the FFT span specifies the frequency range.

When this measurement is tracked with cursors, the cursors are at the far left and right edges of the graticule.

### Occupied Bandwidth

**Occupied Band width** measures the bandwidth (frequency range) containing some percent (usually 99%) of the total spectral power. While 99% is the industry norm, you can specify the percent you want to use in the measurement.

The center frequency used in the measurement is the one defined for the FFT function, and the FFT span represents the total spectral power.

When this measurement is tracked with cursors, the cursors show the measured bandwidth (frequency range).

### Adjacent Channel Power Ratio (ACPR)

Adjacent Channel Power Ratio or just **Adjacent Power Ratio** (or channel leakage ratio) measures the ratio of the power contained in one or more sidebands to the power in the main frequency range.

The main range is specified by a channel width and a center frequency. The Channel Width is one of the measurement's parameters. The center frequency used in the measurement is the one defined for the FFT function.

Sidebands (with the same width as the main range) exist above and below the main range separated by the channel spacing width. The Channel Spacing width is another measurement parameter.

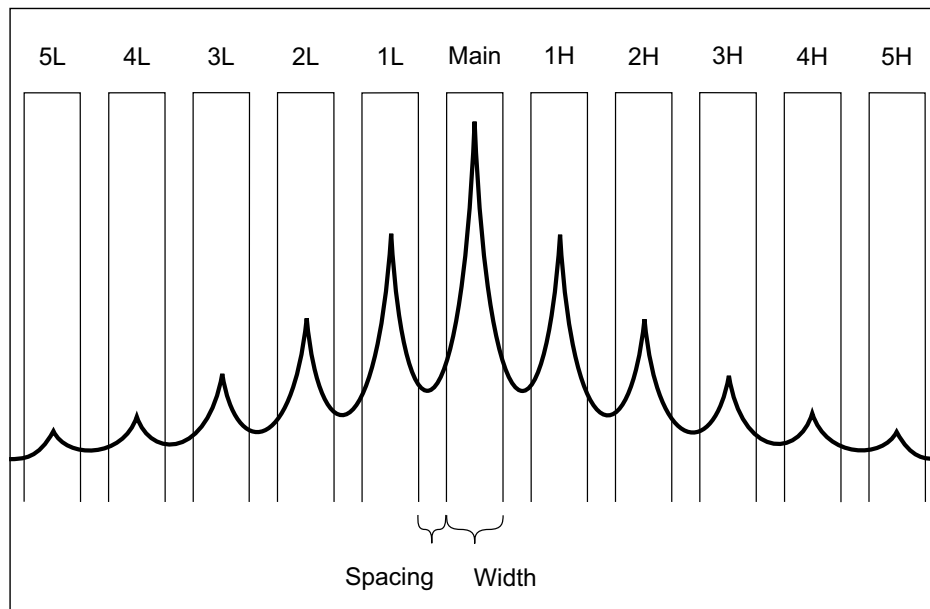

The sideband used for the measurement is selected with the Channel Select parameter. You can select the first through fifth sidebands above or below the main range (1H through 5H above and 1L through 5L below). The full sideband must be in the graticule to be measured. Otherwise, the measurement results will be "Incomplete".

When this measurement is tracked with cursors, the cursors show the sideband being measured.

## Total Harmonic Distortion (THD)

**Total Harmonic Distortion (THD)** is the ratio of power in the fundamental frequency to the power contained in the rest of the harmonics and noise. THD is a measure of signal purity.

**Total Harmonic Distortion (THD)** measures the power contained in the bands surrounding each harmonic and compares it to the power in the band surrounding the fundamental frequency. The width of the bands measured is the same for the fundamental frequency and each harmonic. That width is  $1/2$  of the fundamental frequency.

You can either enter the fundamental frequency as a measurement parameter and have the fundamental frequency and harmonics be tracked manually, or you can allow the fundamental frequency and harmonics to be tracked automatically, where the highest peak is assumed to be the fundamental frequency.

When this measurement is tracked with cursors, the cursors show the band surrounding the fundamental frequency that is being measured (at  $\pm 1/4$  of the fundamental frequency).

## Measurement Thresholds

Setting measurement thresholds defines the vertical levels where measurements will be taken on an analog channel or math waveform.

### NOTE

#### Changing default thresholds may change measurement results

The default lower, middle, and upper threshold values are 10%, 50%, and 90% of the value between Top and Base. Changing these threshold definitions from the default values may change the returned measurement results for Average, Delay, Duty Cycle, Fall Time, Frequency, Overshoot, Period, Phase, Preshoot, Rise Time, +Width, and -Width.

- 1 From the Measurement Menu, click the **Thresholds** softkey to set analog channel measurement thresholds.

You can also open the Measurement Threshold Menu by choosing **Main Menu > Analyze > Analyze Menu**, clicking **Features**, and then selecting **Measurement Thresholds**.

- 2 Click the **Source** softkey to select the analog channel or math waveform source for which you want to change measurement thresholds.

Each analog channel and the math waveform can be assigned unique threshold values.



- 3 Click the **Type** softkey to set the measurement threshold to **%** (percentage of Top and Base value) or to **Absolute** (absolute value).
  - Percentage thresholds can be set from 0% to 100%.
  - The units for absolute threshold for each channel is set in the channel probe menu.

### TIP

#### Absolute threshold hints

- Absolute thresholds are dependent on channel scaling, probe attenuation, and probe units. Always set these values first before setting absolute thresholds.
- The minimum and maximum threshold values are limited to on-screen values.
- If any of the absolute threshold values are above or below the minimum or maximum waveform values, the measurement may not be valid.

- 4 Click the **Lower** softkey; then, enter the lower measurement threshold value.

Increasing the lower value beyond the set middle value will automatically increase the middle value to be more than the lower value. The default lower threshold is 10% or 800 mV.

If threshold **Type** is set to **%**, the lower threshold value can be set from 0% to 98%.

- 5 Click the **Middle** softkey; then, enter the middle measurement threshold value.

The middle value is bounded by the values set for lower and upper thresholds. The default middle threshold is 50% or 1.20 V.

- If threshold **Type** is set to **%**, the middle threshold value can be set from 1% to 99%.

- 6 Click the **Upper** softkey; then, enter the upper measurement threshold value.

Decreasing the upper value below the set middle value will automatically decrease the middle value to be less than the upper value. The default upper threshold is 90% or 1.50 V.

- If threshold **Type** is set to **%**, the upper threshold value can be set from 2% to 100%.

## Measurement Window

You can choose whether measurements are made in the Main window portion of the display, the Zoom window portion of the display (when the zoomed time base is displayed), or gated by the X1 and X2 cursors.

- 1 Choose **Main Menu > Measure > Measurements**.
- 2 In the Measurement Menu, click the **Meas Window** softkey; then, select from:
  - **Auto Select** – When the zoomed time base is displayed, the measurement is attempted in the lower, Zoom window; if it cannot be made there, or if the zoomed time base is not displayed, the Main window is used.
  - **Main** – The measurement window is the Main window.
  - **Zoom** – The measurement window is the lower, Zoom window.
  - **Gated by Cursors** – The measurement window is between the X1 and X2 cursors. When the zoomed time base is displayed, the X1 and X2 cursors in the Zoom window portion of the display are used.



## Measurement Statistics

To display measurement statistics:

- 1 Choose **Main Menu > Measure > Measurements** to display the Measurement Menu. By default, frequency and peak-to-peak voltage are measured on channel 1.
- 2 Select the measurements you desire for the channels you are using (see "[Measurements Summary](#)" on page 208).
- 3 From the Measurement Menu, click the **Statistics** softkey to enter the Statistics Menu.

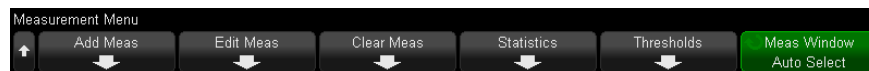

- 4 Click the **Display On** softkey to enable the measurement statistics display.

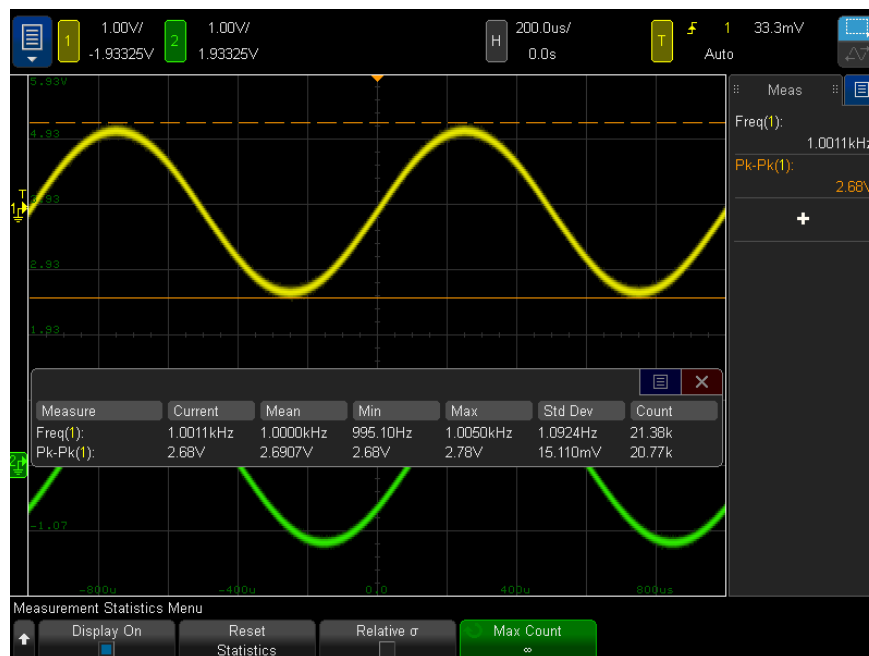

The source channel of the measurement is shown in parenthesis after the measurement name. For example: "**Freq(1)**" indicates a frequency measurement on channel 1.

The following statistics are shown: Name of the measurement, current measured value, mean, minimum measured value, maximum measured value, standard deviation, and the number of times the measurement has been made (count). Statistics are based on the total number of captured waveforms (count).

The standard deviation shown in Statistics is calculated using the same formula used for calculating the standard deviation measurement. The formula is shown in the section titled "**AC RMS**" on page 215.

You can click the **Display On** softkey again to disable the measurement statistics display. Statistics continue to accumulate even when the statistics display is disabled.

- 5 To reset the statistics measurements, click the **Reset Statistics** softkey. This resets all statistics and begins recording statistical data again.

Each time a new measurement (for example: frequency, period, or amplitude) is added the statistics are reset and accumulation of statistical data begins again.

- 6 To enable a relative standard deviation, click the **Relative  $\sigma$**  softkey.

When enabled, the standard deviation shown in measurement statistics becomes the standard deviation/mean.

- 7 To specify the number of values used when calculating measurement statistics, click the **Max Count** softkey and enter the desired value.

Other things to know about measurement statistics:

- When making a single acquisition, statistics are reset and a single measurement is done (count = 1). Successive single acquisitions accumulate statistical data (and the count is incremented).
- The **Increment Statistics** softkey appears only when the acquisition is stopped and the optional segmented memory feature is off. Choose : **Main Menu > Run/Stop** or **Main Menu > Single** to stop the acquisition. You can adjust the horizontal position to pan through the waveform. Active measurements will stay on screen, allowing you to measure various aspects of the captured waveforms. Click **Increment Statistics** to add the currently measured waveform to the collected statistical data.
- The **Analyze Segments** softkey is available when the acquisition is stopped and the optional segmented memory feature is on. After an acquisition has completed (and the oscilloscope is stopped), you can click the **Analyze Segments** softkey to accumulate measurement statistics for the acquired segments.

You can also turn on infinite persistence (in the Display Menu) and click the **Analyze Segments** softkey to create an infinite persistence display.

# 14 Mask Testing

To create a mask from a "golden" waveform (Automask) / 236

Mask Test Setup Options / 238

Mask Statistics / 240

To manually modify a mask file / 242

Building a Mask File / 245

One way to verify a waveform's compliance to a particular set of parameters is to use mask testing. A mask defines a region of the oscilloscope's display in which the waveform must remain in order to comply with chosen parameters. Compliance to the mask is verified point-by-point across the display. Mask test operates on displayed analog channels; it does not operate on channels that are not displayed.

The mask testing feature requires the MASK license that you can get by purchasing the P9240MSKA upgrade.

## To create a mask from a "golden" waveform (Automask)

A golden waveform meets all chosen parameters, and it is the waveform to which all others will be compared.

- 1 Configure the oscilloscope to display the golden waveform.
- 2 Choose **Main Menu > Analyze > Analyze Menu**.
- 3 Click **Features**; then, select **Mask Test**.
- 4 Click **Features** again to enable mask testing.



- 5 Click **Automask**.
- 6 In the Automask Menu, click the **Source** softkey and ensure the desired analog channel is selected.



- 7 Adjust the mask's horizontal tolerance ( $\pm Y$ ) and vertical tolerance ( $\pm X$ ). These are adjustable in graticule divisions or in absolute units (volts or seconds), selectable using the **Units** softkey.
- 8 Click the **Create Mask** softkey.

The mask is created and testing begins.

Whenever the **Create Mask** softkey is clicked the old mask is erased and a new mask is created.

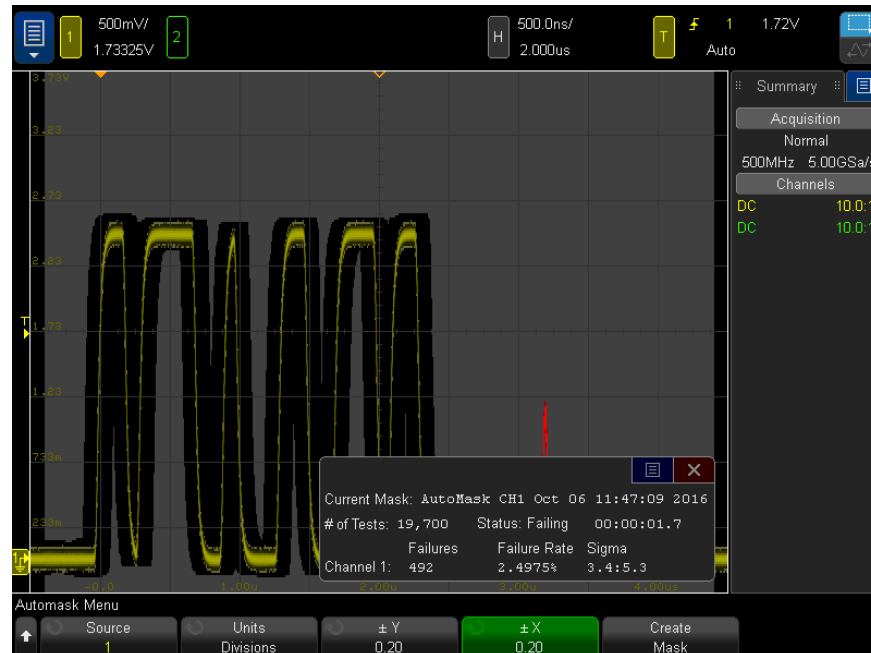

- 9 To clear the mask and switch off mask testing, click the  Back/Up softkey to return to the Mask Test Menu, then click the **Clear Mask** softkey.

If infinite persistence display mode (see "**To set or clear persistence**" on page 114) is "on" when mask test is enabled, it stays on. If infinite persistence is "off" when mask test is enabled, it is switched on when mask test is switched on, then infinite persistence is switched off when mask test is switched off.

#### Troubleshooting Mask Setup

If you click **Create Mask** and the mask appears to cover the entire screen, check the  $\pm Y$  and  $\pm X$  settings in the Automask Menu. If these are set to zero the resulting mask will be extremely tight around the waveform.

If you click **Create Mask** and it appears that no mask was created, check the  $\pm Y$  and  $\pm X$  settings. They may be set so large that the mask is not visible.

## Mask Test Setup Options

From the Mask Test Menu, click the **Setup** softkey to enter the Mask Setup Menu.

<p><b>Run Until</b></p>	<p>The Run Until softkey lets you specify a condition on which to terminate testing.</p> <ul style="list-style-type: none"> <li>▪ <b>Forever</b> – The oscilloscope runs continuously. However, if an error occurs the action specified using the <b>On Error</b> softkey will occur.</li> <li>▪ <b>Minimum # of Tests</b> – Choose this option and then use the <b># of Tests</b> softkey to select the number of times the oscilloscope will trigger, display the waveform(s), and compare them to the mask. The oscilloscope will stop after the specified number of tests have been completed. The specified minimum number of tests may be exceeded. If an error occurs the action specified using the <b>On Error</b> softkey will occur. The actual number of tests completed is displayed above the softkeys.</li> <li>▪ <b>Minimum Time</b> – Choose this option and then use the <b>Test Time</b> softkey to select how long the oscilloscope will run. When the selected time has passed the oscilloscope will stop. The specified time may be exceeded. If an error occurs the action specified using the <b>On Error</b> softkey will occur. The actual test time is displayed above the softkeys.</li> <li>▪ <b>Minimum Sigma</b> – Choose this option and then use the Sigma softkey to select a minimum sigma. The mask test runs until enough waveforms are tested to achieve a minimum test sigma. (If an error occurs the oscilloscope will perform the action specified by the <b>On Error</b> softkey.) Note that this is a test sigma (the max achievable process sigma, assuming no defects, for a certain number of tested waveforms) as opposed to a process sigma (which is tied to the amount of failures per test). The sigma value may exceed the selected value when a small sigma value is chosen. The actual sigma is displayed.</li> </ul>
<p><b>On Error</b></p>	<p>The <b>On Error</b> setting specifies the action(s) to take when the input waveform does not conform to the mask. This setting supersedes the <b>Run Until</b> setting.</p> <ul style="list-style-type: none"> <li>▪ <b>Stop</b> – The oscilloscope will stop when the first error is detected (on the first waveform that does not conform to the mask). This setting supersedes the <b>Minimum # of Tests</b> and <b>Minimum Time</b> settings.</li> <li>▪ <b>Save</b> – The oscilloscope saves the screen image when an error is detected. In the Save Menu (choose <b>Main Menu &gt; File &gt; Save Menu</b>), select an image format (*.bmp or *.png), destination, and file name (which can be auto-incrementing). If errors occur too frequently and the oscilloscope spends all its time saving images, choose <b>Main Menu &gt; Run/Stop</b> to stop acquisitions.</li> <li>▪ <b>Measure</b> – Measurements (and measurement statistics if your oscilloscope supports them) run only on waveforms that contain a mask violation. Measurements are not affected by passing waveforms. This mode is not available when the acquisition mode is set to Averaging.</li> </ul> <p>You can also output a signal on the Aux Out MMCX connector when there is a mask test failure. See "<a href="#">Setting the Aux Out Source</a>" on page 299.</p>

<b>Source Lock</b>	<p>When you turn on Source Lock using the <b>Source Lock</b> softkey, the mask is redrawn to match the source whenever you move the waveform. For example, if you change the horizontal timebase or the vertical gain the mask is redrawn with the new settings.</p> <p>When you turn off Source Lock, the mask is not redrawn when horizontal or vertical settings are changed.</p>
<b>Source</b>	<p>If you change the Source channel, the mask is not erased. It is re-scaled to the vertical gain and offset settings of the channel to which it is assigned. To create a new mask for the selected source channel, go back up in the menu hierarchy; then, click <b>Automask</b>, and click <b>Create Mask</b>.</p> <p>The Source softkey in the Mask Setup Menu is the same as the Source softkey in the Automask Menu.</p>
<b>Test All</b>	<p>When enabled, all displayed analog channels are included in the mask test. When disabled, just the selected source channel is included in the test.</p>

## Mask Statistics

From the Mask Test Menu, click the **Statistics** softkey to enter the Mask Statistics Menu.

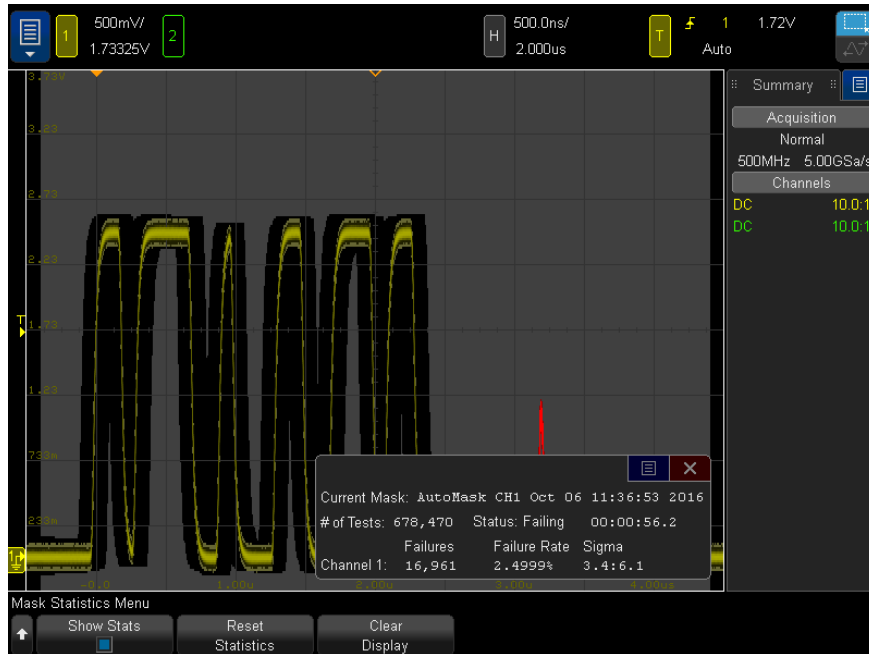

<p><b>Show Stats</b></p>	<p>When you enable <b>Show Statistics</b> the following information is displayed:</p> <ul style="list-style-type: none"> <li>▪ Current mask, name of mask, Channel number, date and time.</li> <li>▪ # of Tests (total number of mask tests executed).</li> <li>▪ Status (Passing, Failing, or Untested).</li> <li>▪ Accumulated test time (in hours, minutes, seconds, and tenths of seconds).</li> </ul> <p>And for each analog channel:</p> <ul style="list-style-type: none"> <li>▪ Number of failures (acquisitions in which the signal excursion went beyond the mask).</li> <li>▪ Failure rate (percentage of failures).</li> <li>▪ Sigma (the ratio of process sigma to maximum achievable sigma, based on number of waveforms tested).</li> </ul>
--------------------------	--



<b>Reset Statistics</b>	Note that statistics are also reset when: <ul style="list-style-type: none"><li>▪ Mask Test is switched on after being switched off.</li><li>▪ Clear Mask softkey is clicked.</li><li>▪ An Automask is created.</li></ul> Additionally, the accumulated time counter is reset whenever the oscilloscope is run after the acquisition was stopped.
<b>Clear Display</b>	Clears acquisition data from the oscilloscope display.

## To manually modify a mask file

You can manually modify a mask file that you created using the Automask function.

- 1 Follow the steps 1-7 in "**To create a mask from a "golden" waveform (Automask)**" on page 236. Do not clear the mask after creating it.
- 2 Choose **Main Menu > File > Save Menu**.
- 3 Click the **Format** softkey and select **Mask**.
- 4 Click the second softkey and select a destination folder on the chassis controller PC.
- 5 Click the **Press to Save** softkey. This creates an ASCII text file that describes the mask.
- 6 Open the .msk file your created using a text editor (such as Wordpad).
- 7 Edit, save, and close the file.

The mask file contains the following sections:

- Mask File Identifier.
- Mask Title.
- Mask Violation Regions.
- Oscilloscope Setup Information.

**Mask File Identifier** The Mask File Identifier is MASK\_FILE\_548XX.

**Mask Title** The Mask Title is a string of ASCII characters. Example: autoMask CH1 OCT 03 09:40:26 2008

When a mask file contains the keyword "autoMask" in the title, the edge of the mask is passing by definition. Otherwise, the edge of the mask is defined as a failure.

## Mask Violation Regions



Up to 8 regions can be defined for a mask. They can be numbered 1-8. They can appear in any order in the .msk file. The numbering of the regions must go from top to bottom, left to right.

An Automask file contains two special regions: the region "glued" to the top of the display, and the region that is "glued" to the bottom. The top region is indicated by y-values of "MAX" for the first and last points. The bottom region is indicated by y-values of "MIN" for the first and last points.

The top region must be the lowest numbered region in the file. The bottom region must be the highest numbered region in the file.

Region number 1 is the top mask region. The vertices in Region 1 describe points along a line; that line is the bottom edge of the top portion of the mask.

Similarly, the vertices in Region 2 describe the line that forms the top of the bottom part of the mask.

The vertices in a mask file are normalized. There are four parameters that define how values are normalized:

- X1
- $\Delta X$
- Y1
- Y2

These four parameters are defined in the Oscilloscope Setup portion of the mask file.

The Y-values (normally voltage) are normalized in the file using the following equation:

$$Y_{\text{norm}} = (Y - Y1)/\Delta Y$$

where  $\Delta Y = Y2 - Y1$

To convert the normalized Y-values in the mask file to voltage:

$$Y = (Y_{\text{norm}} * \Delta Y) + Y1$$

where  $\Delta Y = Y2 - Y1$

The X-values (normally time) are normalized in the file using the following equation:

$$X_{\text{norm}} = (X - X1)/\Delta X$$

To convert the normalized X-values to time:

$$X = (X_{\text{norm}} * \Delta X) + X1$$

### Oscilloscope Setup Information

The keywords "setup" and "end\_setup" (appearing alone on a line) define the beginning and end of the oscilloscope setup region of the mask file. The oscilloscope setup information contains remote programming language commands that the oscilloscope executes when the mask file is loaded.

Any legal remote programming command can be entered in this section.

The mask scaling controls how the normalized vectors are interpreted. This in turn controls how the mask is drawn on the display. The remote programming commands that control mask scaling are:

```
:MTES:SCAL:BIND 0
:MTES:SCAL:X1 -400.000E-06
:MTES:SCAL:XDEL +800.000E-06
:MTES:SCAL:Y1 +359.000E-03
:MTES:SCAL:Y2 +2.35900E+00
```

## Building a Mask File

The following display shows a mask that uses all eight regions.

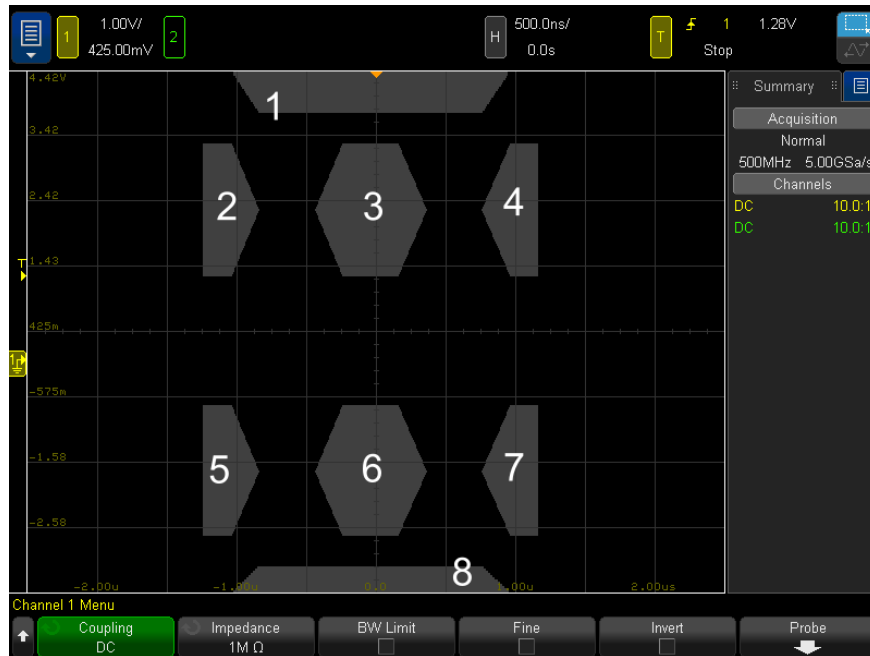

This mask is created by recalling the following mask file:

```
MASK_FILE_548XX
```

```
"All Regions"
```

```
/* Region Number */ 1
/* Number of vertices */ 4
-12.50, MAX
-10.00, 1.750
10.00, 1.750
12.50, MAX
```

```
/* Region Number */ 2
/* Number of vertices */ 5
-10.00, 1.000
-12.50, 0.500
-15.00, 0.500
-15.00, 1.500
-12.50, 1.500
```

```
/* Region Number */ 3
/* Number of vertices */ 6
-05.00, 1.000
-02.50, 0.500
02.50, 0.500
```

```

05.00, 1.000
02.50, 1.500
-02.50, 1.500

/* Region Number */ 4
/* Number of vertices */ 5
10.00, 1.000
12.50, 0.500
15.00, 0.500
15.00, 1.500
12.50, 1.500

/* Region Number */ 5
/* Number of vertices */ 5
-10.00, -1.000
-12.50, -0.500
-15.00, -0.500
-15.00, -1.500
-12.50, -1.500

/* Region Number */ 6
/* Number of vertices */ 6
-05.00, -1.000
-02.50, -0.500
02.50, -0.500
05.00, -1.000
02.50, -1.500
-02.50, -1.500

/* Region Number */ 7
/* Number of vertices */ 5
10.00, -1.000
12.50, -0.500
15.00, -0.500
15.00, -1.500
12.50, -1.500

/* Region Number */ 8
/* Number of vertices */ 4
-12.50, MIN
-10.00, -1.750
10.00, -1.750
12.50, MIN

setup
:CHANnel1:RANGe +8.00E+00
:CHANnel1:OFFSet +2.0E+00
:CHANnel1:DISPlay 1
:TIMEbase:MODE MAIN
:TIMEbase:REFerence CENTER
:TIMEbase:RANGe +50.00E-09
:TIMEbase:POSition +10.0E-09
:MTESt:SOURce CHANnel1
:MTESt:ENABle 1
:MTESt:LOCK 1
:MTESt:SCALe:X1 +10.0E-09
:MTESt:SCALe:XDELta +1.0000E-09

```

```
:MTEST:SCALE:Y1 +2.0E+00
:MTEST:SCALE:Y2 +4.00000E+00
end_setup
```

In a mask file, all region definitions need to be separated by a blank line.

Mask regions are defined by a number of (x,y) coordinate vertices (as on an ordinary x,y graph). A "y" value of "MAX" specifies the top of the graticule, and a "y" value of "MIN" specifies the bottom of the graticule.

The mask x,y graph is related to the oscilloscope graticule using the :MTEST:SCALE setup commands.

The oscilloscope's graticule has a time reference location (at the left, center, or right of the screen) and a trigger (t=0) position/delay value relative to the reference. The graticule also has a vertical ground 0 V reference (offset relative to the center of the screen) location.

The X1 and Y1 setup commands relate the mask region's x,y graph origin to the oscilloscope graticule's t=0 and V=0 reference locations, and the XDELta and Y2 setup commands specify the size of the graph's x and y units.

- The X1 setup command specifies the time location of the x,y graph's x origin.
- The Y1 setup command specifies the vertical location of the x,y graph's y origin.
- The XDELta setup command specifies the amount of time associated with each x unit.
- The Y2 setup command is the vertical location of the x,y graph's y=1 value (so in effect, Y2 – Y1 is the YDELta value).

For example:

- With a graticule whose trigger position is 10 ns (before a center screen reference) and whose ground reference (offset) is 2 V below the center of the screen, to place the mask region's x,y graph's origin at center screen, you would set X1 = 10 ns and Y1 = 2 V.
- If the XDELta parameter is set to 5 ns and Y2 is set to 4 V, a mask region whose vertices are (-1, 1), (1, 1), (1, -1), and (-1, -1) goes from 5 ns to 15 ns and from 0 V to 4 V.
- If you move the mask region's x,y graph origin to the t=0 and V=0 location by setting X1 = 0 and Y1 = 0, the same vertices define a region that goes from -5 ns to 5 ns and from -2 V to 2 V.

#### NOTE

Although a mask can have up to 8 regions, in any given vertical column, it is only possible to define 4 regions. When there are 4 regions in a vertical column, one region must be tied to the top (using the MAX y value) and one must be tied to the bottom (using the MIN y value).

## How is mask testing done?

InfiniiVision oscilloscopes start mask testing by creating a database that is 200 x 640 for the waveform viewing area. Each location in the array is designated as either a violation or a pass area. Each time a data point from a waveform occurs in a violation area a failure is logged. If **Test All** was selected, every active analog channel is tested against the mask database for each acquisition. Over 2 billion failures can be logged per-channel. The number of acquisitions tested is also logged and displayed as "# of Tests".

The mask file allows greater resolution than the 200 X 640 database. Some quantization of data occurs to reduce the mask file data for display on-screen.



# 15 Digital Voltmeter and Counter

Digital Voltmeter / 250  
Counter / 252

The Digital Voltmeter (DVM) and Counter analysis features are standard on the P9241/42/43A oscilloscopes.

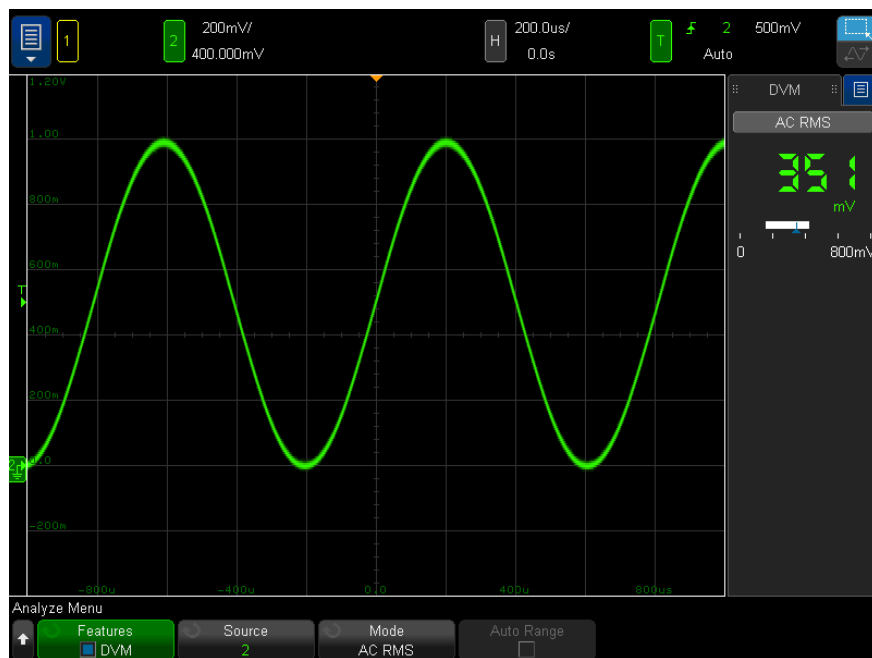

## Digital Voltmeter

The digital voltmeter (DVM) analysis feature provides 3-digit voltage measurements on any analog channel. DVM measurements are asynchronous from the oscilloscope's acquisition system and are always acquiring.

The DVM display is a seven-segment readout like you would see on a digital voltmeter. It shows the selected mode as well as the units. Units are selected using the **Units** softkey in the channel's Probe Menu.

The DVM display also has a scale that is determined by the channel's vertical scale and reference level. The scale's blue triangle pointer shows the most recent measurement. The white bar above that shows the measurement extrema over the last 3 seconds.

The DVM makes accurate RMS measurements when the signal frequency is between 20 Hz and 100 kHz. When the signal frequency is outside this range, "<BW Limit?" or ">BW Limit?" appears in the DVM display to caution you about inaccurate RMS measurement results.

To use the digital voltmeter:

- 1 Choose **Main Menu > Analyze > Analyze Menu**.
- 2 Click **Features**; then, select **Digital Voltmeter**.
- 3 Click **Features** again to enable the DVM measurements.



- 4 Click the **Source** softkey and select the analog channel on which digital voltmeter (DVM) measurements are made.

The selected channel does not have to be on (displaying a waveform) in order for DVM measurements to be made.

- 5 Click the **Mode** softkey and select the digital voltmeter (DVM) mode:
  - **AC RMS** – displays the root-mean-square value of the acquired data, with the DC component removed.
  - **DC** – displays the DC value of the acquired data.
  - **DC RMS** – displays the root-mean-square value of the acquired data.
- 6 If the selected source channel is not used in oscilloscope triggering, click **Auto Range** to disable or enable automatic adjustment of the DVM channel's vertical scale, vertical (ground level) position, and trigger (threshold voltage) level (used for the counter frequency measurement).

When enabled, **Auto Range** overrides attempted adjustments of the channel's vertical scale and position.

When disabled, you can adjust the channel's vertical scale and position normally.

## Counter

The counter analysis feature provides frequency, period, or edge event (totalize) counter measurements on any analog channel.

The counter counts trigger level crossings within a certain amount of time (gate time) and displays the results on a seven-segment readout (like you would see on a standalone counter instrument).

For frequency and period counter measurements:

- The gate time is specified indirectly by the selected number of digits of resolution, from 3 to 8. For higher resolutions, the gate time is greater.
- Up to 1 GHz (1.2 GHz typical) frequencies can be measured. With 8 digits of resolution, the counter will saturate for signals greater than 470 MHz.

For totalize measurements:

- A running count of edges is kept. You can choose whether to count positive or negative edges, and when edge triggering on any analog channel, you can gate the count with a positive or negative pulse on a second analog channel.
- Edge events with up to 1 GHz (1.2 GHz typical) frequencies can be counted.
- When gating the count, the gating signal setup time is 0 ns typical and the hold time is 3.5 ns typical when using similar probes for the totalize source and the gate source.

The counter is asynchronous from the oscilloscope's acquisition system and is always acquiring.

To use the counter:

- 1 Choose **Main Menu > Analyze > Analyze Menu**.
- 2 Click **Features**; then, select **Counter**.
- 3 Click **Features** again to enable the counter.



- 4 Click the **Source** softkey and select the analog channel or **Trigger Qualified Event** signal to make counter measurements on.

With the **Trigger Qualified Event** source (available when the trigger mode is not Edge), you can see how often trigger events are detected. This can be more often than when triggers actually occur, due to the oscilloscope's acquisition time or update rate capabilities. The Aux Out signal can show when triggers actually occur. Remember that the oscilloscope's trigger circuitry does not re-arm until the holdoff time occurs and that the minimum holdoff time is 40 ns; therefore, the maximum trigger qualified event frequency that can be counted is 25 MHz.

The selected channel does not have to be on (displaying a waveform) in order for counter measurements to be made.

- 5 Click the **Auto Setup Threshold** softkey to have the oscilloscope automatically determine and set the threshold voltage (trigger) level for the selected analog channel source.
- 6 Click the **Measure** softkey and select what the counter measures:
  - **Frequency** – the cycles per second (Hz, kHz, or MHz) of the signal.
  - **Period** – the time periods of the signal's cycles.
  - **Totalize** – the count of edge events on the signal.

**Frequency and Period Counter** For frequency and period measurements, click the **# of Digits** softkey to specify the resolution of the counter. You can choose from 3 to 8 digit resolutions.

Higher resolutions require longer gate times, which cause the measurement times to be longer as well.

**Totalize Counter** For (edge event) totalize measurements, click the **Clear Count** softkey to zero the edge event counter.

Click the **Totalize** softkey to open the Counter Totalize Menu where you can:



- Click the **Source** softkey to change the analog channel on which counter measurements are made.
- Click the **Event Slope** softkey to choose whether positive or negative edge events are counted.
- Click the **Gate** softkey to enable or disable gating of the edge event count using a positive or negative level on a second analog channel.

When gating is enabled:

- a Click the **Gate Source** softkey and select the analog channel that will supply the gating signal.

The selected channel does not have to be on (displaying a waveform).

- b Click the polarity softkey to choose whether positive or negative levels are used to gate the edge event count.

The trigger level for the selected analog channel is used to determine the polarity of the signal.



# 16 Frequency Response Analysis

To make connections / 256

To set up and run the analysis / 257

To view and save the analysis results / 259

Frequency Response Analysis (FRA) is a licensed feature you can get by purchasing the P9240FRAA upgrade.

The Frequency Response Analysis (FRA) feature controls the built-in waveform generator to sweep a sine wave across a range of frequencies while measuring the input to and output from a device under test (DUT). At each frequency, gain (A) and phase are measured and plotted on a frequency response Bode chart.

When the frequency response analysis completes, you can move a marker across the chart to see the measured gain and phase values at each frequency point. You can also adjust the chart's scale and offset settings for the gain and phase plots.

## To make connections

The waveform generator output is connected to a device under test (DUT). The input to the device and the output from the device are probed by the oscilloscope's input channels.

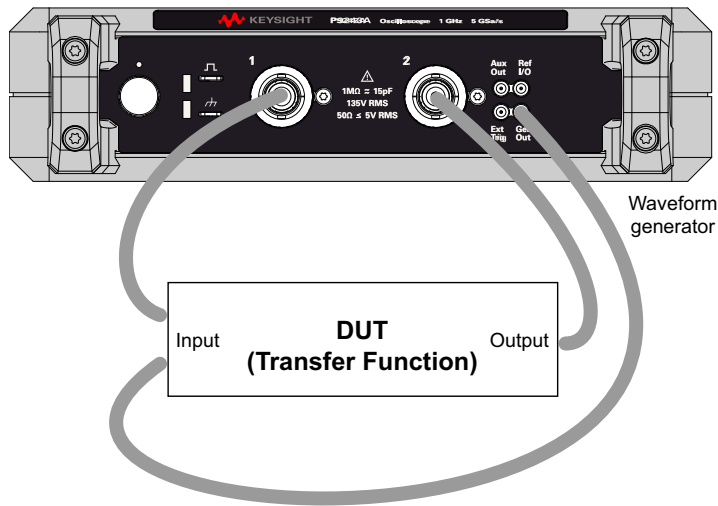



## To set up and run the analysis

- 1 Choose **Main Menu > Analyze > Analyze Menu**.
- 2 Click **Features**; then, select **Frequency Response Analysis**.
- 3 Click **Features** again to enable the feature.



- 4 Click the **Setup & Apply...** softkey to open the Frequency Response Analysis dialog box's tab for setting up the swept frequency response analysis.



There are settings for:

- The start and stop frequencies in the sweep, as well as the number of points per decade.
- The channels probing the input and output. (Click the help icon to view a connection diagram.)
- The waveform generator amplitude and expected output load impedance.

To specify different amplitudes for different decades, select **Amplitude Profile**.

The output impedance of the Gen Out signal is fixed at 50 ohms. However, the output load selection lets the waveform generator display the correct amplitude and offset levels for the expected output load. If the actual load impedance is different than the selected value, the displayed amplitude and offset levels will be incorrect.

- 5 Click the **Run Analysis** softkey.

## To view and save the analysis results

Click the **Plot...** softkey to open the Frequency Response Analysis dialog box's tab for viewing the analysis results in a Bode plot.

The plot shows both gain and phase measurements versus frequency. There are two markers that can be dragged to view actual values along the plot. There is a control in the upper right corner for enabling or disabling the gain or phase plots, adjusting the scale/offset of the plots, or autoscaling.

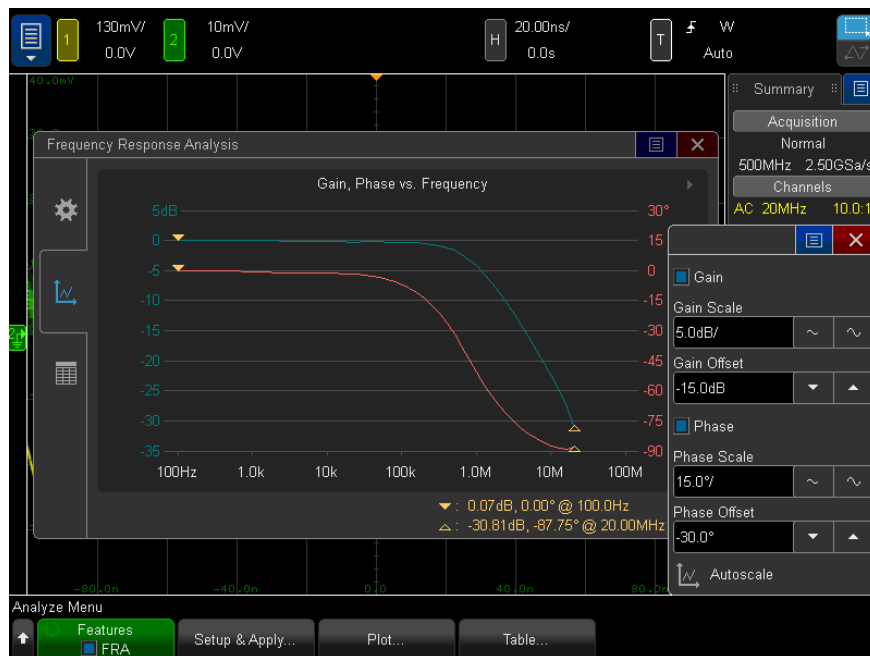

Click the **Table...** softkey to open the Frequency Response Analysis dialog box's tab for viewing the analysis results in table form.

The table shows: the data point number, the frequency, the waveform generator output amplitude, the measured gain, and the measured phase. You can scroll the data. There is a menu control in the upper right corner for enabling or disabling the gain or phase table data.



You can save (or e-mail) the analysis results by choosing **Main Menu > File > Save Menu**, clicking **Format**, and selecting the **Frequency Response Analysis data (\*.csv)** option.

# 17 Waveform Generator

To select generated waveform types and settings / 262

To edit arbitrary waveforms / 265

Output Settings / 271

To use waveform generator logic presets / 273

To add noise to the waveform generator output / 274

To add modulation to the waveform generator output / 275

To restore waveform generator defaults / 279

A waveform generator is built into the oscilloscope. It is enabled by the P9240AWGA upgrade license. The waveform generator gives you an easy way to provide input signals when testing circuitry with the oscilloscope.

Waveform generator settings can be saved and recalled with oscilloscope setups. See [Chapter 18](#), “Save/Email/Recall (Setups, Screens, Data),” starting on page 281.

## To select generated waveform types and settings

- 1 To access the Waveform Generator Menu and enable or disable the waveform generator output on the front panel Gen Out MMCX connector, choose **Main Menu > Sources > Waveform Generator**.

The waveform generator output is always disabled when the instrument is first turned on.

The waveform generator output is automatically disabled if excessive voltage is applied to the Gen Out MMCX connector.

- 2 In the Waveform Generator Menu, click the **Waveform** softkey and select the waveform type.

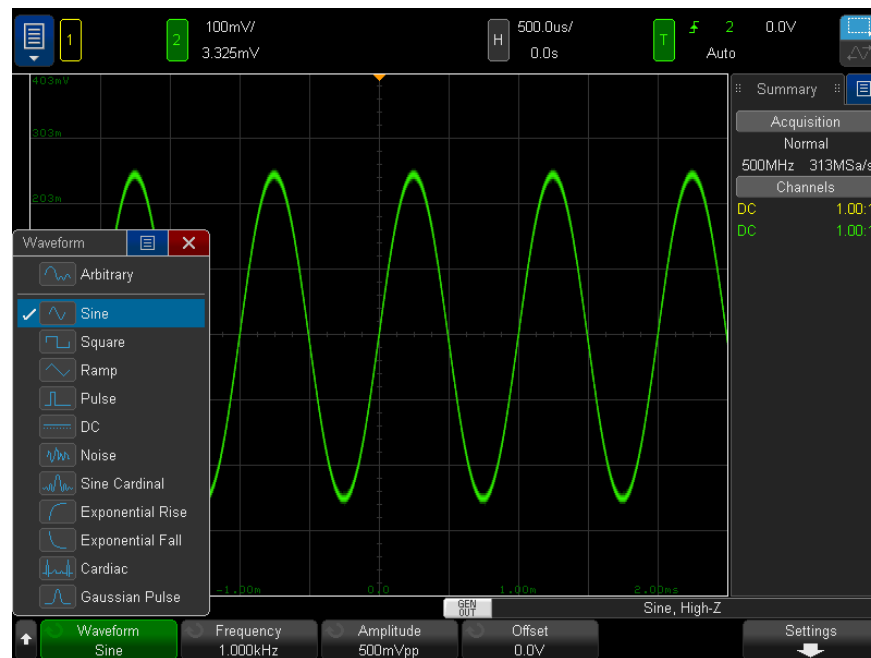

- 3 Depending on the selected waveform type, use the remaining softkeys to set the waveform's characteristics.

Waveform Type	Characteristics	Frequency Range	Max. Amplitude (High-Z) <sup>1</sup>	Offset (High-Z) <sup>1</sup>
Arbitrary	Use the <b>Frequency/Frequency Fine/Period/Period Fine, Amplitude/High-Level, and Offset/Low-Level</b> softkeys to set the arbitrary waveform signal parameters.  Use the <b>Ed it Waveform</b> softkey to define the arbitrary waveform shape. See " <b>To edit arbitrary waveforms</b> " on page 265.	100 mHz to 12 MHz	20 mVpp to 5 Vpp	±2.50 V
Sine	Use the <b>Frequency/Frequency Fine/Period/Period Fine, Amplitude/High-Level, and Offset/Low-Level</b> softkeys to set the sine signal parameters.	100 mHz to 20 MHz	20 mVpp to 5 Vpp	±2.50 V
Square	Use the <b>Frequency/Frequency Fine/Period/Period Fine, Amplitude/High-Level, Offset/Low-Level, and Duty Cycle</b> softkeys to set the square wave signal parameters.  The duty cycle can be adjusted from 20% to 80%.	100 mHz to 10 MHz	20 mVpp to 5 Vpp	±2.50 V
Ramp	Use the <b>Frequency/Frequency Fine/Period/Period Fine, Amplitude/High-Level, Offset/Low-Level, and Symmetry</b> softkeys to set the ramp signal parameters.  Symmetry represents the amount of time per cycle that the ramp waveform is rising and can be adjusted from 0% to 100%.	100 mHz to 200 kHz	20 mVpp to 5 Vpp	±2.50 V
Pulse	Use the <b>Frequency/Frequency Fine/Period/Period Fine, Amplitude/High-Level, Offset/Low-Level, and Width/Width Fine</b> softkeys to set the pulse signal parameters.  The pulse width can be adjusted from 20 ns to the period minus 20 ns.	100 mHz to 10 MHz.	20 mVpp to 5 Vpp	±2.50 V
DC	Use the <b>Offset</b> softkey to set the DC level.	n/a	n/a	±5.00 V
Noise	Use the <b>Amplitude/High-Level and Offset/Low-Level</b> to set the noise signal parameters.	n/a	20 mVpp to 5 Vpp	±2.50 V
Sine Cardinal	Use the <b>Frequency/Frequency Fine/Period/Period Fine, Amplitude, and Offset</b> softkeys to set the sinc signal parameters.	100 mHz to 1 MHz	20 mVpp to 5 Vpp	±1.25 V
Exponential Rise	Use the <b>Frequency/Frequency Fine/Period/Period Fine, Amplitude/High-Level, and Offset/Low-Level</b> softkeys to set the exponential rise signal parameters.	100 mHz to 5 MHz	20 mVpp to 5 Vpp	±2.50 V

Waveform Type	Characteristics	Frequency Range	Max. Amplitude (High-Z) <sup>1</sup>	Offset (High-Z) <sup>1</sup>
Exponential Fall	Use the <b>Frequency/Frequency Fine/Period/Period Fine, Amplitude/High-Level, and Offset/Low-Level</b> softkeys to set the exponential fall signal parameters.	100 mHz to 5 MHz	20 mVpp to 5 Vpp	±2.50 V
Cardiac	Use the <b>Frequency/Frequency Fine/Period/Period Fine, Amplitude, and Offset</b> softkeys to set the cardiac signal parameters.	100 mHz to 200 kHz	20 mVpp to 5 Vpp	±1.25 V
Gaussian Pulse	Use the <b>Frequency/Frequency Fine/Period/Period Fine, Amplitude, and Offset</b> softkeys to set the Gaussian pulse signal parameters.	100 mHz to 5 MHz	20 mVpp to 4 Vpp	±1.25 V

<sup>1</sup>When the output load is 50 Ω, these values are halved.

Clicking a signal parameter softkey can open a menu for selecting the type of adjustment. For example, you can choose to enter amplitude and offset values, or you can choose to enter high-level and low-level values. Or, you can choose to enter frequency values or period values. Keep clicking the softkey to select the type of adjustment.

The **Settings** softkey opens the Waveform Generator Settings Menu which lets you make other settings related to the waveform generator.



See:

- **"To output the waveform generator sync pulse"** on page 272
- **"To specify the expected output load"** on page 271
- **"To use waveform generator logic presets"** on page 273
- **"To add modulation to the waveform generator output"** on page 275
- **"To add noise to the waveform generator output"** on page 274
- **"To restore waveform generator defaults"** on page 279



## To edit arbitrary waveforms

- 1 When **Arbitrary** is selected as the generated waveform type (see **"To select generated waveform types and settings"** on page 262), click the **Edit Waveform** softkey to open the Edit Waveform Menu.



When you open the Edit Waveform Menu, you see the existing arbitrary waveform definition. The voltage and time period you see in the diagram are the bounding parameters – they come from the frequency and amplitude settings in the main Waveform Generator Menu.

- 2 Use the softkeys in the Edit Waveform Menu to define the shape of the arbitrary waveform:

Softkey	Description
<b>Create New</b>	Opens the New Waveform Menu. See " <b>Creating New Arbitrary Waveforms</b> " on page 266.
<b>Edit Existing</b>	Opens the Edit Waveform Points Menu. See " <b>Editing Existing Arbitrary Waveforms</b> " on page 267.
<b>Interpolate</b>	Specifies how lines are drawn between arbitrary waveform points. When enabled, lines are drawn between points in the waveform editor. Voltage levels change linearly between one point and the next. When disabled, all line segments in the waveform editor are horizontal. The voltage level of one point remains until the next point.
<b>Source</b>	Selects the analog channel or reference waveform to be captured and stored to the arbitrary waveform. See " <b>Capturing Other Waveforms to the Arbitrary Waveform</b> " on page 270.
<b>Store Source to Arb</b>	Captures the selected waveform source and copy it to the arbitrary waveform. See " <b>Capturing Other Waveforms to the Arbitrary Waveform</b> " on page 270.

**NOTE**

Choose **Main Menu > File > Save Menu** and use the Save Menu to save arbitrary waveforms that you can recall later. See "**To save arbitrary waveforms**" on page 287 and "**To recall arbitrary waveforms**" on page 291.

## Creating New Arbitrary Waveforms

The New Waveform Menu is opened by clicking **Create New** in the Edit Waveform Menu.



To create a new arbitrary waveform:

- 1 In the New Waveform Menu, click **Initial Pts**; then, select the initial number of points in the new waveform.  
The new waveform will be a square wave with the number of points you specify. The points are evenly spaced over the time period.
- 2 Use the **Frequency/Frequency Fine/Period/Period Fine** softkey to set the time period bounding parameter (repetition frequency) of the arbitrary waveform.
- 3 Use the **Amplitude/High-Level** and **Offset/Low-Level** softkeys to set the voltage bounding parameter of the arbitrary waveform.
- 4 When you are ready to create the new arbitrary waveform, click **Apply & Edit**.

**CAUTION**

When you create a new arbitrary waveform, the existing arbitrary waveform definition is overwritten. Note that you can choose **Main Menu > File > Save Menu** and use the Save Menu to save arbitrary waveforms that you can recall later. See **"To save arbitrary waveforms"** on page 287 and **"To recall arbitrary waveforms"** on page 291.

The new waveform is created and the Edit Waveform Points menu is opened. See **"Editing Existing Arbitrary Waveforms"** on page 267.

Note that you can also create a new arbitrary waveform by capturing another waveform. See **"Capturing Other Waveforms to the Arbitrary Waveform"** on page 270.

## Editing Existing Arbitrary Waveforms

### Using the Mouse to Edit Existing Waveforms

To select a point, click or drag in the upper, full waveform display:

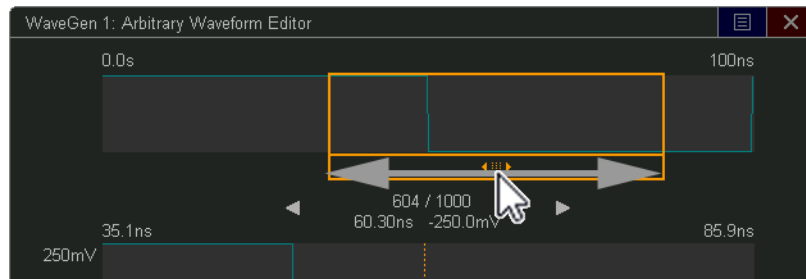

For fine points selection, click the previous point or next point arrows:

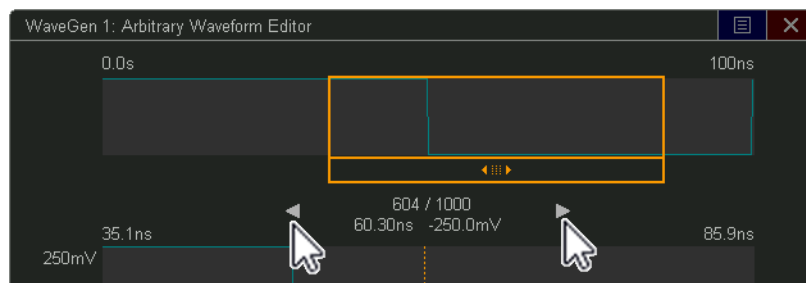

To adjust the value of a point, drag the voltage level handle up or down:

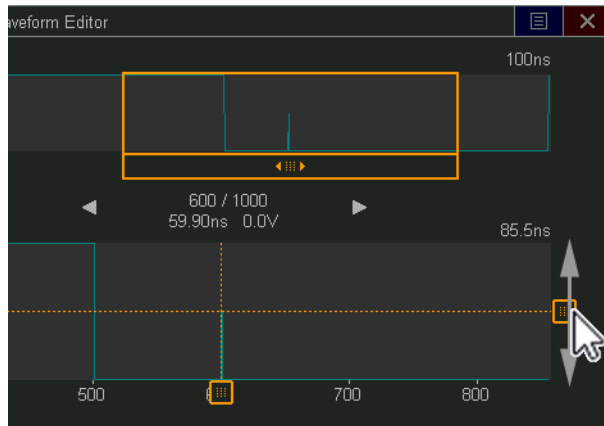

To select a points region, drag across the upper or lower waveform display:

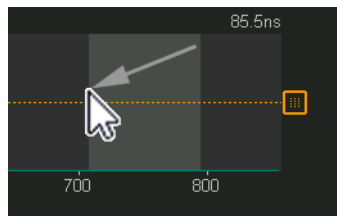

For fine adjustment of the region selection (or to clear the selection), click the edit tab, and use the **Selected Region** controls:

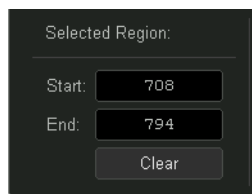

To perform points operations, click the **Operation** controls drop-down, select the operation, and use the controls for the selected operation:

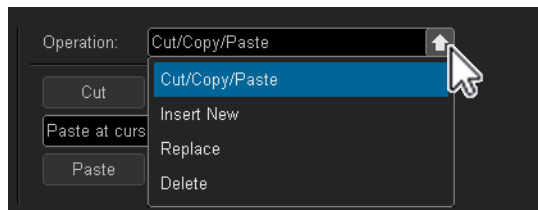

- **Cut/Copy** selected points regions to the clipboard and **Paste** points from the clipboard.

When pasting points from the clipboard, you can paste at the beginning, end, cursor location (currently selected point), or you can replace the currently selected points region.

- **Insert New** points.  
You can specify the number of new points and their voltage.
- **Replace** a selected points region with new points.
- **Delete** a selected points region.

To navigate the arbitrary waveform (and select points), drag the point selection handle left or right across the display area:

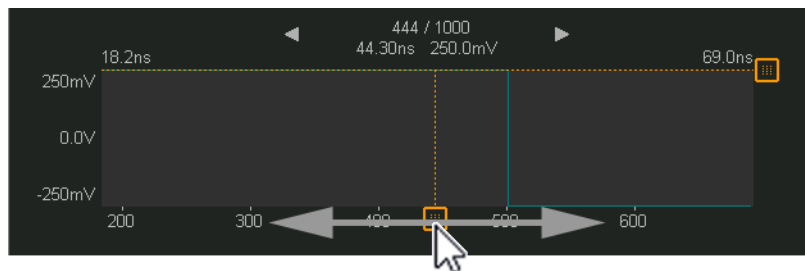

### Using Softkeys to Edit Existing Waveforms

The Edit Waveform Points Menu is opened by clicking **Edit Existing** in the Edit Waveform Menu or by clicking **Apply & Edit** when creating a new arbitrary waveform.

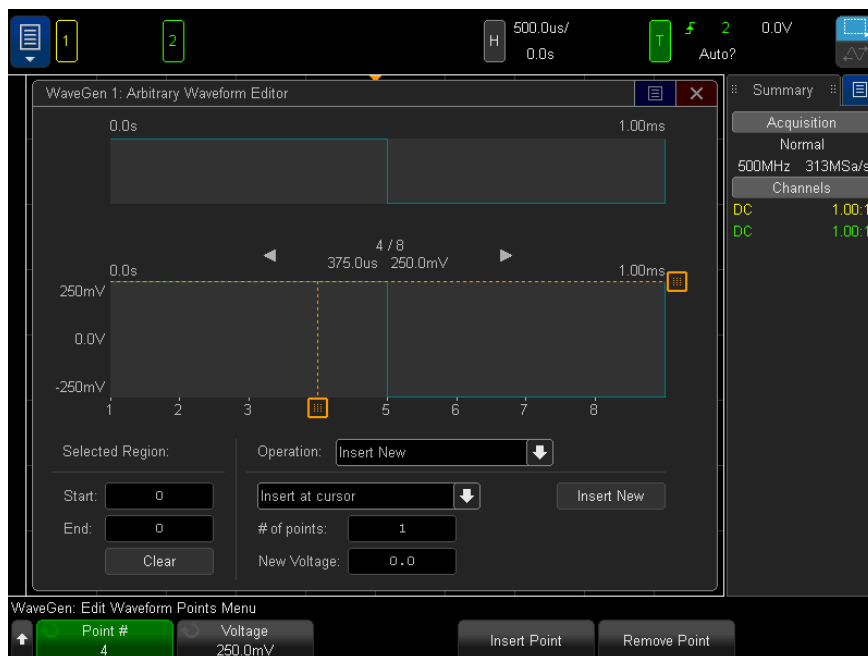

To specify the voltage values of points:

- 1 Click **Point #**; then, select the point whose voltage value you wish to set.
- 2 Click **Voltage**; then, set the point's voltage value.

To insert a point:

- 1 Click **Point #**; then, select the point after which the new point will be inserted.
- 2 Click **Insert Point**.

All points are adjusted to maintain uniform time spacing between points.

To remove a point:

- 1 Click **Point #**; then, select the point you want to remove.
- 2 Click **Remove Point**.

All points are adjusted to maintain uniform time spacing between points.

## Capturing Other Waveforms to the Arbitrary Waveform

The Edit Waveform Menu is opened by clicking **Edit Waveform** in the main Waveform Generator Menu.

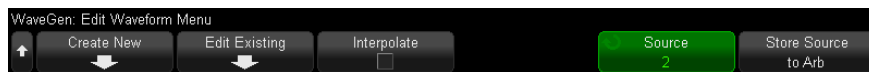

To capture another waveform to the arbitrary waveform:

- 1 Click **Source**; then, select the analog channel, math, or reference location whose waveform you wish to capture.
- 2 Click **Store Source to Arb**.

### CAUTION

When you create a new arbitrary waveform, the existing arbitrary waveform definition is overwritten. Note that you can choose **Main Menu > File > Save Menu** and use the **Save Menu** to save arbitrary waveforms that you can recall later. See **"To save arbitrary waveforms"** on page 287 and **"To recall arbitrary waveforms"** on page 291.

The source waveform is decimated into 8192 (maximum) or fewer arbitrary waveform points.

### NOTE

If the source waveform frequency and/or voltage exceed the capabilities of the waveform generator, the arbitrary waveform will be limited to the capabilities of the waveform generator. For example, a 20 MHz waveform captured as the arbitrary waveform, becomes a 12 MHz waveform.

## Output Settings

- "To specify the expected output load" on page 271
- "To invert the waveform generator output" on page 271
- "To output a single-shot waveform" on page 272
- "To output the waveform generator sync pulse" on page 272

### To specify the expected output load

- 1 If the Waveform Generator Menu is not currently displayed on the oscilloscope's softkeys, choose **Main Menu > Sources > Waveform Generator**.
- 2 In the Waveform Generator Menu, click the **Settings** softkey.
- 3 In the Waveform Generator Settings Menu, click the **Output Settings** softkey.
- 4 In the Waveform Generator Output Settings Menu, click the **Output Load** softkey and select:
  - **50  $\Omega$**
  - **High-Z**

The output impedance of the Gen Out MMCX is fixed at 50 ohms. However, the output load selection lets the waveform generator display the correct amplitude and offset levels for the expected output load.

If the actual load impedance is different than the selected value, the displayed amplitude and offset levels will be incorrect.

### To invert the waveform generator output

You can invert the shape of the generated waveform output:

- 1 If the Waveform Generator Menu is not currently displayed on the oscilloscope's softkeys, choose **Main Menu > Sources > Waveform Generator**.
- 2 In the Waveform Generator Menu, click the **Settings** softkey.
- 3 In the Waveform Generator Settings Menu, click the **Output Settings** softkey.
- 4 In the Waveform Generator Output Settings Menu, click the **Invert Output** softkey to enable or disable an inverted output.

The waveform's offset is not inverted.

## To output a single-shot waveform

You can set up the waveform generator to output one cycle of the defined waveform:

- 1 If the Waveform Generator Menu is not currently displayed on the oscilloscope's softkeys, choose **Main Menu > Sources > Waveform Generator**.
- 2 In the Waveform Generator Menu, click the **Settings** softkey.
- 3 In the Waveform Generator Settings Menu, click the **Output Settings** softkey.
- 4 In the Waveform Generator Output Settings Menu, click the **Output Mode** softkey and select **Single-Shot**.
- 5 Click the **Transmit Single-Shot** softkey.

This will output one cycle of the defined waveform.

Clicking this softkey multiple times will interrupt a slow signal output before its cycle is completed.

Note that the transmit single-shot action can also be mapped to the **Main Menu > Quick Action** menu item (see "[Configuring the Quick Action Menu Item](#)" on page 304) or as a control in the sidebar **Controls** dialog box (see "[Select Sidebar Information or Controls](#)" on page 27).

To return to normal waveform generator output, click the **Output Mode** softkey and select **Normal**.

## To output the waveform generator sync pulse

- 1 If the Waveform Generator Menu is not currently displayed on the oscilloscope's softkeys, choose **Main Menu > Sources > Waveform Generator**.
- 2 In the Waveform Generator Menu, click the **Settings** softkey.
- 3 In the Waveform Generator Settings Menu, click the **Output Settings** softkey.
- 4 In the Waveform Generator Output Settings Menu, click the **Aux Out** softkey and select **Waveform Generator Sync Pulse**.

Waveform Type	Sync Signal Characteristics
All waveforms except DC, Noise, and Cardiac	The Sync signal is a TTL positive pulse that occurs when the waveform rises above zero volts (or the DC offset value).
DC, Noise, and Cardiac	N/A



## To use waveform generator logic presets

With logic level presets, you can easily set the output voltage to TTL, CMOS (5.0V), CMOS (3.3V), CMOS (2.5V), or ECL compatible Low and High levels.

- 1 If the Waveform Generator Menu is not currently displayed on the oscilloscope's softkeys, choose **Main Menu > Sources > Waveform Generator**.
- 2 In the Waveform Generator Menu, click the **Settings** softkey.
- 3 In the Waveform Generator Settings Menu, click the **Logic Presets** softkey.
- 4 In the Waveform Generator Logic Level Presets Menu, click one of the softkeys to set the generated signal's Low and High voltages to logic compatible levels:

Softkey (logic levels)	Low level	High level
<b>TTL</b>	0 V	+5 V (or a TTL-compatible high level if +5 V cannot be reached)
<b>CMOS (5.0V)</b>	0 V	+5 V
<b>CMOS (3.3V)</b>	0 V	+3.3 V
<b>CMOS (2.5V)</b>	0 V	+2.5 V
<b>ECL</b>	-1.7 V	-0.9 V

## To add noise to the waveform generator output

- 1 If the Waveform Generator Menu is not currently displayed on the oscilloscope's softkeys, choose **Main Menu > Sources > Waveform Generator**.
- 2 In the Waveform Generator Menu, click the **Settings** softkey.
- 3 In the Waveform Generator Settings Menu, click the **Add Noise** softkey and select the amount of white noise to add to the waveform generator output.

Note that adding noise affects edge triggering on the waveform generator source (see "**Edge Trigger**" on page 133) as well as the waveform generator sync pulse output signal (which can be sent to Aux Out, see "**Setting the Aux Out Source**" on page 299). This is because the trigger comparator is located after the noise source.

## To add modulation to the waveform generator output

Modulation is where an original carrier signal is modified according to the amplitude of a second modulating signal. The modulation type (AM, FM, or FSK) specifies how the carrier signal is modified.

Modulated waveforms are available on the WaveGen1 output.

To enable and set up modulation for the waveform generator output:

- 1 If the Waveform Generator Menu is not currently displayed on the oscilloscope's softkeys, choose **Main Menu > Sources > Waveform Generator**.
- 2 In the Waveform Generator Menu, click the **Settings** softkey.
- 3 In the Waveform Generator Settings Menu, click the **Modulation** softkey.
- 4 In the Waveform Generator Modulation Menu:



- Click the **Modulation** softkey to enable or disable modulated waveform generator output.

You can enable modulation for all waveform generator function types except arbitrary, square, pulse, DC, noise, and Gaussian pulse.

- Click the **Type** softkey and select the modulation type:
  - **Amplitude Modulation (AM)** – the amplitude of the original carrier signal is modified according to the amplitude of the modulating signal. See "[To set up Amplitude Modulation \(AM\)](#)" on page 275.
  - **Frequency Modulation (FM)** – the frequency of the original carrier signal is modified according to the amplitude of the modulating signal. See "[To set up Frequency Modulation \(FM\)](#)" on page 276.
  - **Frequency-Shift Keying Modulation (FSK)** – the output frequency "shifts" between the original carrier frequency and a "hop frequency" at the specified FSK rate. The FSK rate specifies a digital square wave modulating signal. See "[To set up Frequency-Shift Keying Modulation \(FSK\)](#)" on page 278.

## To set up Amplitude Modulation (AM)

In the Waveform Generator Modulation Menu (choose **Main Menu > Sources > Waveform Generator**, then click **Settings > Modulation**):

- 1 Click the **Type** softkey and select **Amplitude Modulation (AM)**.
- 2 Click the **Waveform** softkey and select the shape of the modulating signal:
  - **Sine**

- **Square**
- **Ramp**

When the **Ramp** shape is selected, a **Symmetry** softkey appears so that you can specify the amount of time per cycle that the ramp waveform is rising.

- 3 Click the **AM Freq** softkey and enter the frequency of the modulating signal.
- 4 Click the **AM Depth** softkey and enter the amount of amplitude modulation.

AM Depth refers to the portion of the amplitude range that will be used by the modulation. For example, a depth setting of 80% causes the output amplitude to vary from 10% to 90% ( $90\% - 10\% = 80\%$ ) of the original amplitude as the modulating signal goes from its minimum to maximum amplitude.

The following screen shows an AM modulation of a 100 kHz sine wave carrier signal.

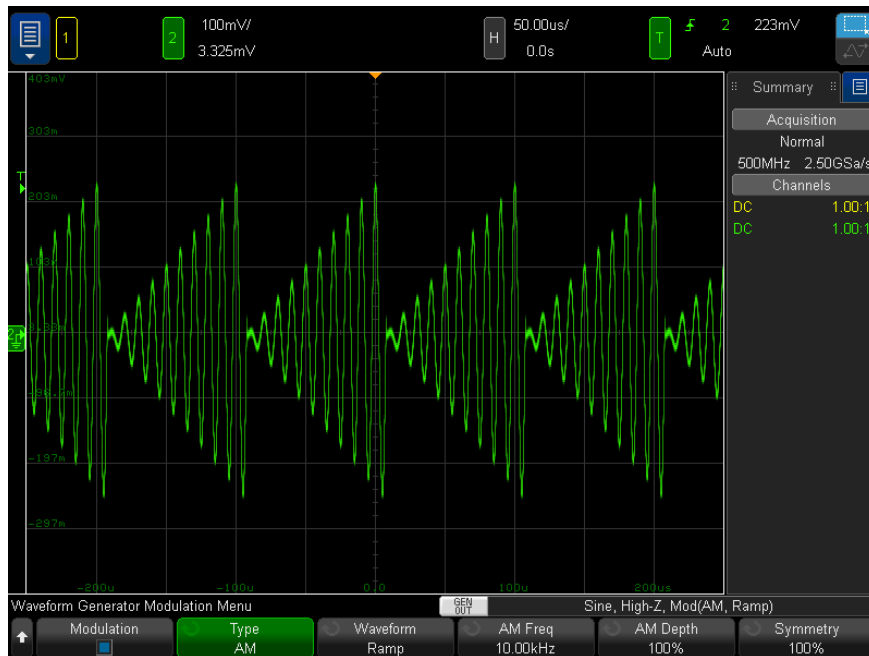

## To set up Frequency Modulation (FM)

In the Waveform Generator Modulation Menu (choose **Main Menu > Sources > Waveform Generator**, then click **Settings > Modulation**):

- 1 Click the **Type** softkey and select **Frequency Modulation (FM)**.
- 2 Click the **Waveform** softkey and select the shape of the modulating signal:
  - **Sine**
  - **Square**

### Ramp

When the **Ramp** shape is selected, a **Symmetry** softkey appears so that you can specify the amount of time per cycle that the ramp waveform is rising.

- 3 Click the **FM Freq** softkey and enter the frequency of the modulating signal.
- 4 Click the **FM Dev** softkey and enter the frequency deviation from the original carrier signal frequency.

When the modulating signal is at its maximum amplitude, the output frequency is the carrier signal frequency plus the deviation amount, and when the modulating signal is at its minimum amplitude, the output frequency is the carrier signal frequency minus the deviation amount.

The frequency deviation cannot be greater than the original carrier signal frequency.

Also, the sum of the original carrier signal frequency and the frequency deviation must be less than or equal to the maximum frequency for the selected waveform generator function plus 100 kHz.

The following screen shows an FM modulation of a 100 kHz sine wave carrier signal.

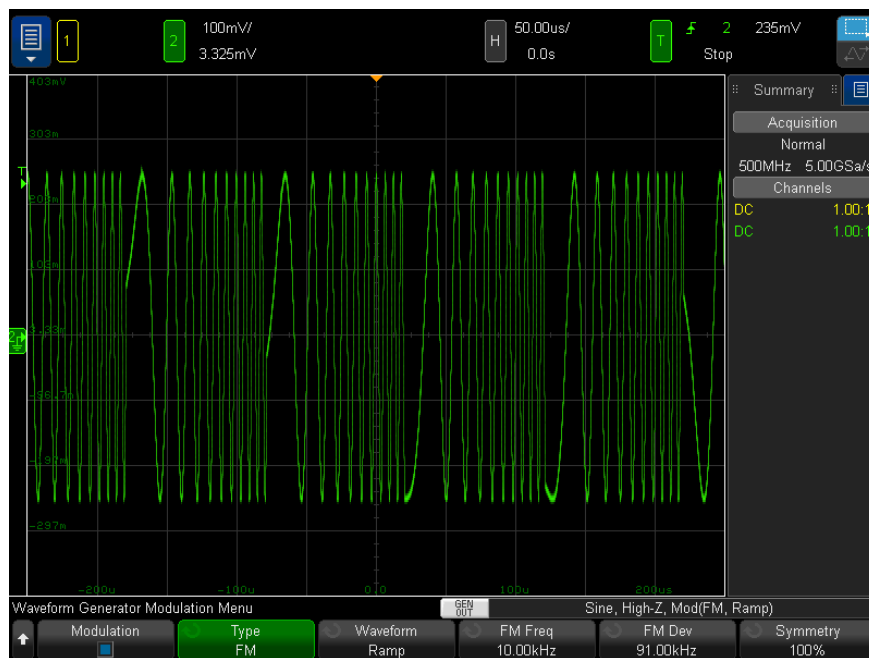

## To set up Frequency-Shift Keying Modulation (FSK)

In the Waveform Generator Modulation Menu (choose **Main Menu > Sources > Waveform Generator**, then click **Settings > Modulation**):

- 1 Click the **Type** softkey and select **Frequency-Shift Keying Modulation (FSK)**.
- 2 Click the **Hop Freq** softkey and enter the "hop frequency".

The output frequency "shifts" between the original carrier frequency and this "hop frequency".

- 3 Click the **FSK Rate** softkey and enter the rate at which the output frequency "shifts".

The FSK rate specifies a digital square wave modulating signal.

The following screen shows an FSK modulation of a 100 kHz sine wave carrier signal.

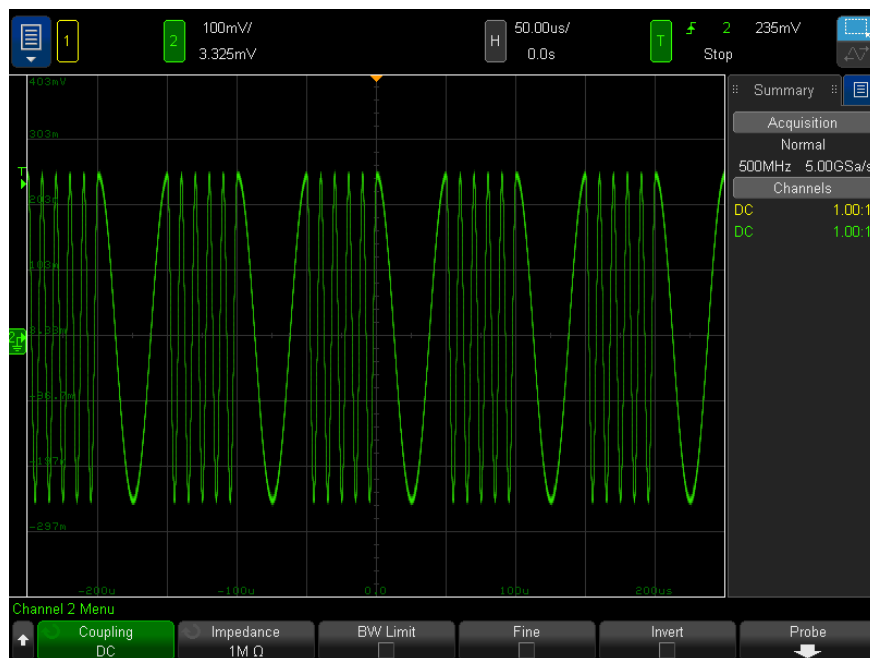

## To restore waveform generator defaults

- 1 If the Waveform Generator Menu is not currently displayed on the oscilloscope's softkeys, choose **Main Menu > Sources > Waveform Generator**.
- 2 In the Waveform Generator Menu, click the **Settings** softkey.
- 3 In the Waveform Generator Settings Menu, click the **Default Wave Gen** softkey.

The waveform generator factory default settings (1 kHz sine wave, 500 mVpp, 0 V offset, High-Z output load) are restored.





# 18 Save/Email/Recall (Setups, Screens, Data)

Saving Setups, Screen Images, or Data / 282

Emailing Setups, Screen Images, or Data / 289

Recalling Setups, Masks, or Data / 290

Recalling Default Setups / 292

Oscilloscope setups, reference waveforms, and mask files can be saved to files on the chassis controller PC and recalled later. You can also recall default or factory default setups.

Oscilloscope screen images can be saved in BMP or PNG formats.

Acquired waveform data can be saved in comma-separated value (CSV), ASCII XY, and binary (BIN) formats.

Files can also be e-mailed over the network.

## Saving Setups, Screen Images, or Data

- 1 Choose **Main Menu > File > Save Menu**.
- 2 In the save menu, click **Format**; then, select the type of file you want to save:
  - **Setup (\*.scp)** – The oscilloscope's horizontal timebase, vertical sensitivity, trigger mode, trigger level, measurements, cursors, and math function settings that tell the oscilloscope how to make a particular measurement. See **"To save setup files"** on page 283.
  - **8-bit Bitmap image (\*.bmp)** – The complete screen image in a reduced color (8-bit) bitmap format. See **"To save BMP or PNG image files"** on page 283.
  - **24-bit Bitmap image (\*.bmp)** – The complete screen image in a 24-bit color bitmap format. See **"To save BMP or PNG image files"** on page 283.
  - **24-bit image (\*.png)** – The complete screen image in a 24-bit color PNG format that uses lossless compression. Files are much smaller than the BMP format. See **"To save BMP or PNG image files"** on page 283.
  - **CSV data (\*.csv)** – This creates a file of comma-separated values of all displayed channels and math waveforms. This format is suitable for spreadsheet analysis. See **"To save CSV, ASCII XY, or BIN data files"** on page 284.
  - **ASCII XY data (\*.csv)** – This creates separate files of comma-separated values for each displayed channel. This format is also suitable for spreadsheets. See **"To save CSV, ASCII XY, or BIN data files"** on page 284.
  - **Binary data (\*.bin)** – This creates a binary file, with a header, and data in the form of time and voltage pairs. This file is much smaller than the ASCII XY data file. See **"To save CSV, ASCII XY, or BIN data files"** on page 284.
  - **Lister data (\*.csv)** – This is a CSV format file containing serial decode row information with commas separating the columns. See **"To save Lister data files"** on page 286.
  - **Reference Waveform data (\*.h5)** – Saves waveform data in a format that can be recalled to one of the oscilloscope's reference waveform locations. See **"To save reference waveform files"** on page 286.
  - **Multi Channel Waveform data (\*.h5)** – Saves multiple channels of waveform data in a format that can be opened by the N8900A Infiniium Offline oscilloscope analysis software. You can recall the first Analog or Math channel from a multi channel waveform data file.
  - **Mask (\*.msk)** – This creates a mask file in a Keysight proprietary format that can be read by Keysight InfiniiVision oscilloscopes. A mask data file includes some oscilloscope setup information, but not all setup information. To save all setup information including the mask data file, choose "Setup (\*.scp)" format instead. See **"To save masks"** on page 287.

- **Arbitrary Waveform data (\*.csv)** – This creates a file of comma-separated values for the arbitrary waveform points' time and voltage values. See "[To save arbitrary waveforms](#)" on page 287.
- **Analysis Results (\*.csv)** – A file of comma-separated values is saved for the analysis types selected using the **Analysis Select** softkey.
- **Frequency Response Analysis data (\*.csv)** – This creates a file of comma-separated values for the Frequency Response Analysis results table values. In the saved file, there are three data columns: frequency (Hz), gain (dB), and phase (degrees). See "[To view and save the analysis results](#)" on page 259.

You can also configure the **Main Menu > Quick Action** menu item to save setups, screen images, or data. See "[Configuring the Quick Action Menu Item](#)" on page 304.

## To save setup files

Setup files can be saved to the chassis controller PC's file system.

- 1 Choose **Main Menu > File > Save Menu**.
- 2 In the save menu, click **Format**; then, select **Setup (\*.scp)**.
- 3 Click the softkey in the second position and navigate to the save location. See "[To navigate storage locations](#)" on page 287.
- 4 Finally, click the **Press to Save** softkey.

A message indicating whether the save was successful is displayed.

Setup files have the extension SCP. These extensions appear when using the File Explorer (see "[File Explorer](#)" on page 294), but they do not appear when using the Recall Menu.

## To save BMP or PNG image files

Image files can be saved to the chassis controller PC's file system.

- 1 Choose **Main Menu > File > Save Menu**.
- 2 In the save menu, click **Format**; then, select **8-bit Bitmap image (\*.bmp)**, **24-bit Bitmap image (\*.bmp)**, or **24-bit image (\*.png)**.
- 3 Click the softkey in the second position and navigate to the save location. See "[To navigate storage locations](#)" on page 287.
- 4 Click the **Settings** softkey.

In the File Settings Menu, you have these softkeys and options:

- **Setup Info** – setup information (vertical, horizontal, trigger, acquisition, math, and display settings) is also saved in a separate file with a TXT extension.
- 5 Finally, click the **Press to Save** softkey.

A message indicating whether the save was successful is displayed.

#### NOTE

When saving screen images, the oscilloscope uses the last menu visited before choosing **Main Menu > File > Save Menu**. This lets you save any relevant information within the softkey menu area.

To save a screen image showing the Save/Recall Menu at the bottom, choose **Main Menu > File > Save Menu** twice before saving the image.

See Also · ["To add an annotation"](#) on page 119

### To save CSV, ASCII XY, or BIN data files

Data files can be saved to the chassis controller PC's file system.

- 1 Choose **Main Menu > File > Save Menu**.
- 2 In the save menu, click **Format**; then, select **CSV data (\*.csv)**, **ASCII XY data (\*.csv)**, or **Binary data (\*.bin)**.
- 3 Click the softkey in the second position and navigate to the save location. See ["To navigate storage locations"](#) on page 287.
- 4 Click the **Settings** softkey.

In the File Settings Menu, you have these softkeys and options:

- **Setup Info** – when enabled, setup information (vertical, horizontal, trigger, acquisition, math, and display settings) is also saved in a separate file with a TXT extension.
- **Max Length** – when enabled, the maximum number of waveform points is saved.
- **Length** – sets the number of data points that will be output to the file. For more information, see ["Length Control"](#) on page 285.
- **Save Seg** – when data is acquired to segmented memory, you can specify whether the currently displayed segment is saved or all acquired segments are saved. (See also ["Saving Data from Segmented Memory"](#) on page 193.)

- 5 Finally, click the **Press to Save** softkey.

A message indicating whether the save was successful is displayed.

**CSV Data** When the CSV data (\*.csv) file format is selected, comma-separated values for each displayed waveform are saved as multiple columns in a single file. Math FFT waveforms, whose values are in the frequency domain, are appended at the bottom of the .csv file. Waveform labels are used as column headers. This format is suitable for spreadsheet analysis.

For CSV data, length "N" value-at-time measurements are performed across the entire screen (using the measurement record data) for each active source. Interpolation between measurement record data points is performed as needed.

**ASCII XY Data** When the ASCII XY data (\*.csv) file format is selected, comma-separated value files for each displayed waveform and serial bus are saved. An underscore and the waveform's label are appended.

If the oscilloscope acquisition is stopped, data from the raw acquisition record (which has more points than the measurement record) can be written. Choose **Main Menu > Single** to obtain maximum memory depth with current settings. If enabled, serial decode data is saved.

When you want to save less than the maximum number of data points, a 1-of-N decimation is performed to produce an output whose length is less than or equal to the requested length. For example, if there are 100k points of data, and you specify a length of 2k, 1 of every 50 data points is saved.

- See Also**
- **"Binary Data (.bin) Format"** on page 310
  - **"CSV and ASCII XY files"** on page 317
  - **"Minimum and Maximum Values in CSV Files"** on page 317

## Length Control

The **Length** control is available when saving data to CSV, ASCII XY, or BIN format files. It sets the number of data points that will be output to the file. Only displayed data points are saved.

When **Max Length** is enabled, the maximum number of waveform data points is saved.

The maximum number of data points depends on these things:

- Whether acquisitions are running. When stopped, data comes from the raw acquisition record. When running, data comes from the smaller measurement record.
- Whether the oscilloscope was stopped during a running acquisition or after a single acquisition. Running acquisitions split memory to provide fast waveform update rates. Single acquisitions use full memory.
- Whether only one channel of a pair is turned on. (Channels 1 and 2 are one pair.) Acquisition memory is divided among the channels in a pair.
- Whether reference waveforms are on. Displayed reference waveforms consume acquisition memory.
- Whether segmented memory is on. Acquisition memory is divided by the number of segments.
- The horizontal time/div (sweep speed) setting. At faster settings, fewer data points appear on the display.
- When saving to a CSV format file, the maximum number of data points is 64K.

When necessary, the Length control performs a "1 of n" decimation of the data . For example: if the **Length** is set to 1000, and you are displaying a record that is 5000 data points in length, four of each five data points will be decimated, creating an output file 1000 data points in length.

When saving waveform data, the save times depend on the chosen format:

Data File Format	Save Times
BIN	fastest
ASCII XY	medium
CSV	slowest

- See Also
- ["Binary Data \(.bin\) Format"](#) on page 310
  - ["CSV and ASCII XY files"](#) on page 317
  - ["Minimum and Maximum Values in CSV Files"](#) on page 317

## To save Lister data files

Lister data files can be saved to the chassis controller PC's file system.

- 1 Choose **Main Menu > File > Save Menu**.
- 2 In the save menu, click **Format**; then, select **Lister data (\*.csv)**.
- 3 Click the softkey in the second position and navigate to the save location. See ["To navigate storage locations"](#) on page 287.
- 4 Click the **Settings** softkey.

In the File Settings Menu, you have these softkeys and options:

- **Setup Info** – when enabled, setup information (vertical, horizontal, trigger, acquisition, math, and display settings) is also saved in a separate file with a TXT extension.
- 5 Finally, click the **Press to Save** softkey.
- A message indicating whether the save was successful is displayed.

## To save reference waveform files

- 1 Choose **Main Menu > File > Save Menu**.
- 2 In the save menu, click **Format**; then, select **Reference Waveform data (\*.h5)**.
- 3 Click the **Source** softkey and select the source waveform.
- 4 Click the softkey in the second position and navigate to the save location. See ["To navigate storage locations"](#) on page 287.
- 5 Finally, click the **Press to Save** softkey.

A message indicating whether the save was successful is displayed.

## To save masks

- 1 Choose **Main Menu > File > Save Menu**.
- 2 In the save menu, click **Format**; then, select **Mask (\*.msk)**.
- 3 Click the softkey in the second position and navigate to the save location. See **"To navigate storage locations"** on page 287.
- 4 Finally, click the **Press to Save** softkey.

A message indicating whether the save was successful is displayed.

Mask files have the extension MSK.

### NOTE

Masks are also saved as part of setup files. See **"To save setup files"** on page 283.

See Also · **Chapter 14**, "Mask Testing," starting on page 235

## To save arbitrary waveforms

Arbitrary waveform files can be saved to the chassis controller PC's file system.

- 1 Choose **Main Menu > File > Save Menu**.
- 2 In the save menu, click **Format**; then, select **Arbitrary Waveform data (\*.csv)**.
- 3 Click the softkey in the second position and navigate to the save location. See **"To navigate storage locations"** on page 287.
- 4 Finally, click the **Press to Save** softkey.

A message indicating whether the save was successful is displayed.

See Also · **"To edit arbitrary waveforms"** on page 265

## To navigate storage locations

When saving or recalling files, the softkey in the second position of the Save Menu or Recall Menu is used to navigate to storage locations. The storage locations are on the chassis controller PC.

The softkey in the second position can have these labels:

- **Press to go** – when you can click the button to navigate to a new folder or storage location.
- **Location** – when you have navigated to the current folder location (and are not saving files).
- **Save to** – when you can save to the selected location.

- **Load from** – when you can recall from the selected file.

When saving files:

- The proposed file name is shown in the **Save to file =** line above the softkeys.
- To overwrite an existing file, browse to that file and select it. To create a new file name, see "**To enter file names**" on page 288.

## To enter file names

To create new file names when saving files:

- 1 In the Save Menu, click the **File Name** softkey.
- 2 In the File Name Menu, click the **File Name** softkey.
- 3 In the File Name keypad dialog, you can enter file names using a keyboard or by clicking keypad dialog box keys with a mouse.
- 4 When you are done entering the file name, click the dialog's Enter or OK key or click the **File Name** softkey again.

The file name appears in the softkey.

- 5 When available, the **Increment** softkey can be used to enable or disable automatically incremented file names. Auto increment adds a numeric suffix to your file name and increments the number with each successive save. It will truncate characters as necessary when the file name length is at maximum and more digits are required for the numeric portion of the file name.



## Emailing Setups, Screen Images, or Data

You can send oscilloscope files over the network via e-mail. You can e-mail any file that can be saved.

To e-mail a setup, screen image, or data file:

- 1 Choose **Main Menu > File > Email Menu**.
- 2 In the Email Menu, click **Format**; then, select the type of file you want to send.

You can select from the same formats that are available when saving files. Settings for the selected format are also the same. See "**Saving Setups, Screen Images, or Data**" on page 282.

- 3 Click the **Attachment Name** softkey and use the keypad dialog to enter the name of the attachment file that will be sent.
- 4 In the e-mail configuration dialog box, click the **To**, **From**, **Server**, and **Subject** fields and use the keypad dialog to enter the appropriate strings.

You can also enter these strings by clicking the **Config Email** softkey and clicking the **To**, **From**, **Server**, and **Subject** softkeys in the **Configure Email Menu**.

You can specify multiple e-mail addresses by separating each address by a semi-colon.

The Server name is the name of your mail server running the Simple Mail Transfer Protocol (SMTP). If you do not know this name, ask your Network Administrator.

- 5 Finally, click the **Press to Send Email** softkey.

You can also configure the **Main Menu > Quick Action** menu item to e-mail setups, screen images, or data. See "**Configuring the Quick Action Menu Item**" on page 304.

## Recalling Setups, Masks, or Data

- 1 Choose **Main Menu > File > Recall Menu**.
- 2 In the Recall Menu, click **Recall:**, then, select the type of file you want to recall:
  - **Setup (\*.scp)** – See ["To recall setup files"](#) on page 290.
  - **Mask (\*.msk)** – See ["To recall mask files"](#) on page 290.
  - **Reference Waveform data (\*.h5)** – See ["To recall reference waveform files"](#) on page 291.
  - **Arbitrary Waveform data (\*.csv)** – See ["To recall arbitrary waveforms"](#) on page 291.
  - **CAN Symbolic data (\*.dbc)** – For CAN serial decode.
  - **LIN Symbolic data (\*.ldf)** – For LIN serial decode.

You can also recall setups and mask files by loading them using the File Explorer. See ["File Explorer"](#) on page 294.

You can also configure the **Main Menu > Quick Action** menu item to recall setups, masks, or reference waveforms. See ["Configuring the Quick Action Menu Item"](#) on page 304.

### To recall setup files

Setup files can be recalled from the chassis controller PC's file system.

- 1 Choose **Main Menu > File > Recall Menu**.
- 2 In the Recall Menu, click **Recall:**, then, select **Setup (\*.scp)**.
- 3 Click the softkey in the second position and navigate to the file to recall. See ["To navigate storage locations"](#) on page 287.
- 4 Click the **Press to Recall** softkey.  
A message indicating whether the recall was successful is displayed.
- 5 If you would like to clear the display, click **Clear Display**.

### To recall mask files

Mask files can be recalled from the chassis controller PC's file system.

- 1 Choose **Main Menu > File > Recall Menu**.
- 2 In the Recall Menu, click **Recall:**, then, select **Mask (\*.msk)**.
- 3 Click the softkey in the second position and navigate to the file to recall. See ["To navigate storage locations"](#) on page 287.
- 4 Click the **Press to Recall** softkey.  
A message indicating whether the recall was successful is displayed.

- 5 If you would like to clear the display or clear the recalled mask, click **Clear Display** or **Clear Mask**.

## To recall reference waveform files

- 1 Choose **Main Menu > File > Recall Menu**.
- 2 In the Recall Menu, click **Recall:**, then, select **Reference Waveform data (\*.h5)**.
- 3 Click the **To Ref:** softkey and select the desired reference waveform location.
- 4 Click the softkey in the second position and navigate to the file to recall. See **"To navigate storage locations"** on page 287.
- 5 Click the **Press to Recall** softkey.

A message indicating whether the recall was successful is displayed.

- 6 If you would like to clear the display of everything except the reference waveform, click **Clear Display**.

## To recall arbitrary waveforms

Arbitrary waveform files can be recalled from the chassis controller PC's file system.

When recalling arbitrary waveforms that were not saved from the oscilloscope, be aware that:

- If the file contains two columns, the second column is automatically chosen.
- If the file contains more than two columns, you are prompted to select which column to load. Up to five columns are parsed by the oscilloscope; columns above the fifth are ignored.
- The oscilloscope uses a maximum of 8192 points for an arbitrary waveform. For more efficient recalls, make sure your arbitrary waveforms are 8192 points or less.

To recall an arbitrary waveform:

- 1 Choose **Main Menu > File > Recall Menu**.
- 2 In the Recall Menu, click **Recall:**, then, select **Arbitrary Waveform data (\*.csv)**.
- 3 Click the softkey in the second position and navigate to the file to recall. See **"To navigate storage locations"** on page 287.
- 4 Click the **Press to Recall** softkey.

A message indicating whether the recall was successful is displayed.

- 5 If you would like to clear the display, click **Clear Display**.

See Also • **"To edit arbitrary waveforms"** on page 265

## Recalling Default Setups

- 1 Choose **Main Menu > File > Default Menu**.
- 2 In the Default Menu, click one of these softkeys:
  - **Default Setup**— recalls the oscilloscope's default setup. This is the same as choosing **Main Menu > Default SetupMenu**.  
Some user settings are not changed when recalling the default setup.
  - **Factory Default**— recalls the oscilloscope's factory default settings.  
You must confirm the recall because there are no user settings that are left unchanged.

# 19 Utility Settings

- File Explorer / 294
- Setting Oscilloscope Preferences / 295
- Setting the Reference Signal Mode / 297
- Setting the Aux Out Source / 299
- Enabling Remote Command Logging / 300
- Performing Service Tasks / 301
- Configuring the Quick Action Menu Item / 304

This chapter explains oscilloscope utility functions.

## File Explorer

The File Explorer lets you navigate the chassis controller PC's file system from which you can load setup files, mask files, label files, etc. Also, you can delete files.

To use the File Explorer:

- 1 Choose **Main Menu > File > File Explorer Menu**.
- 2 In the File Explorer Menu, click the softkey in the first position to navigate.



The softkey in the first position can have these labels:

- **Press to go** – when you can click the softkey to navigate to a new folder or storage location.
- **Location** – when pointing to a directory that is currently selected.
- **Selected** – when pointing to a file that can be loaded or deleted.

When this label appears, you can click the **Load File** or **Delete File** softkeys to take the action.

**See Also** • **Chapter 18**, “Save/Email/Recall (Setups, Screens, Data),” starting on page 281

## Setting Oscilloscope Preferences

The User Preferences Menu (choose **Main Menu > Utilities > User Options Menu** then click **Preferences**) lets you specify oscilloscope preferences.

- **"To choose "expand about" center or ground"** on page 295
- **"To set Autoscale preferences"** on page 295

### To choose "expand about" center or ground

When you change a channel's volts/division setting, the waveform display can be set to expand (or compress) about the signal ground level or the center of the display.

To set the waveform expansion reference point:

- 1 Choose **Main Menu > Utilities > User Options Menu**.
- 2 In the User Options Menu, click **Preferences**.
- 3 In the User Preferences Menu, click **Expand** and select:
  - **Ground**— The displayed waveform will expand about the position of the channel's ground. This is the default setting.

The ground level of the signal is identified by the position of the ground level (⚡) icon at the far-left side of the display.

The ground level will not move when you adjust the vertical sensitivity (volts/division) control.

If the ground level is off screen, the waveform will expand about the top or bottom edge of the screen based on where the ground is off screen.
- **Center**— The displayed waveform will expand about the center of the display.

### To set Autoscale preferences

- 1 Choose **Main Menu > Utilities > User Options Menu**.
- 2 In the User Options Menu, click **Preferences**.
- 3 In the User Preferences Menu, click **Autoscale**.
- 4 In the Autoscale Preferences Menu, you can:
  - Click the **Fast Debug** softkey enable/disable this type of autoscale.

When fast debug is enabled, autoscale lets you make quick visual comparisons to determine whether the signal being probed is a DC voltage, ground, or an active AC signal.

Channel coupling is maintained to allow easy viewing of oscillating signals.
- Click the **Channels** softkey and specify the channels to be autoscaled:

- **All Channels** – The next time you choose **Main Menu > Autoscale**, all channels that meet the requirements of Autoscale will be displayed.
- **Only Displayed Channels** – The next time you choose **Main Menu > Autoscale**, only the channels that are turned on will be examined for signal activity. This is useful if you only want to view specific active channels after Autoscale.
- Click the **Acq Mode** softkey and select whether the acquisition mode should be preserved during autoscale:
  - **Normal** – to make the oscilloscope switch to Normal acquisition mode whenever you Autoscale. This is the default mode.
  - **Preserve** – to make the oscilloscope remain in the currently selected acquisition mode when you Autoscale.



## Setting the Reference Signal Mode

The **Ref I/O** MMCX connector is provided so you can:

- Supply a more accurate external sample clock signal to the oscilloscope. See **"To use an external sample clock"** on page 297.
- Synchronize the timebase of external instruments. See **"To output the oscilloscope's system clock"** on page 298.

### To use an external sample clock

- 1 Connect a 10 MHz square or sine wave to the MMCX connector labeled **Ref I/O**. The amplitude must be from -5 dBm to 17 dBm (356 mVpp to 4.48 Vpp).

#### CAUTION

#### **Maximum input voltage at Ref I/O connector**

Do not apply more than 20 dBm Max (6.32 Vpp Max) at the Ref I/O MMCX connector or damage to the instrument may occur.

- 2 Choose **Main Menu > Utilities > User Options Menu**.
- 3 In the User Options Menu, click **Auxiliary I/O**.
- 4 In the Auxiliary I/O Menu, click **10MHz Ref Signal** and select **Input On**.

A locked padlock icon appears at the top of the display.

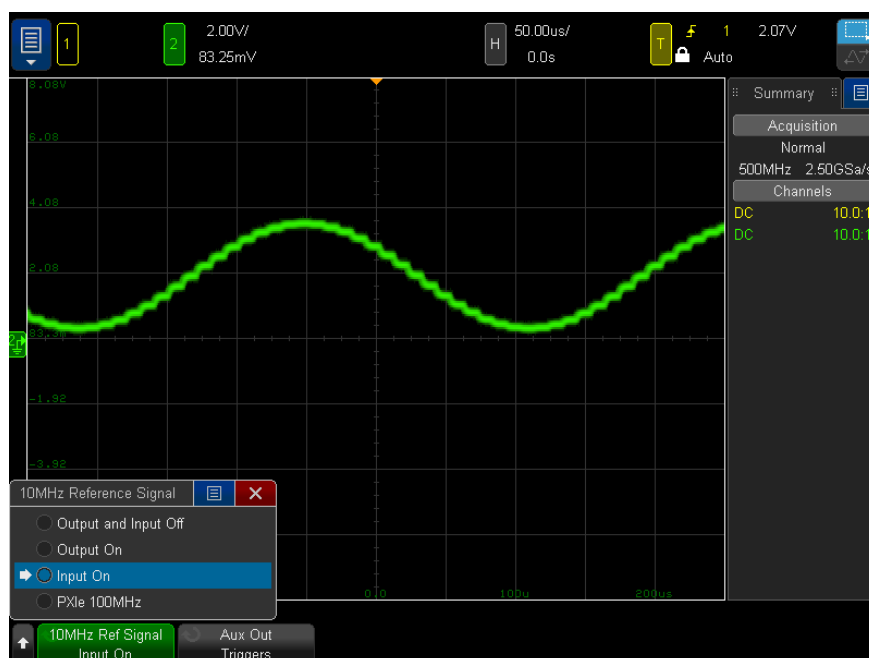

If the externally supplied sample clock signal is lost, a hard unlock will occur. The lock symbol in the upper right part of the display will become an unlocked padlock icon and the oscilloscope will stop acquiring data. The oscilloscope will resume sampling when the externally supplied sample clock becomes stable again.

#### Sample clock and frequency counter accuracy

The oscilloscope's timebase uses a built-in reference that has an accuracy of 15 ppm. This is sufficient for most uses. However, if you are looking at a window that is very narrow compared to the selected delay (for example, looking at a 15 ns pulse with the delay set to 1 ms), significant error can be introduced.

Using the built-in sample clock, the oscilloscope's hardware frequency counter is a 5-digit counter.

When you supply an external timebase reference, the hardware frequency counter is automatically changed to an 8-digit counter. In this case, the frequency counter (**Main Menu > Measure > Measurements, Type: Counter**) is as accurate as the external clock.

For more information on the hardware frequency counter, see **"Counter"** on page 219.

### To output the oscilloscope's system clock

The oscilloscope can output its 10 MHz system clock for the purpose of synchronization with external instruments.

- 1 Connect a cable to the MMCX connector labeled **Ref I/O** on the oscilloscope.
- 2 Connect the other end of the cable to the instrument(s) that will accept the 10 MHz reference signal.

The amplitude of this 10 MHz reference output signal is 5 Vpp into a high impedance or 2.5 Vpp into 50 Ohms. It is capable of driving into lower impedances, but the output will be reduced because of the 50 Ohm source impedance.

- 3 Choose **Main Menu > Utilities > User Options Menu**.
- 4 In the User Options Menu, click **Auxiliary I/O**.
- 5 In the Auxiliary I/O Menu, click **10MHz Ref Signal** and select **Output On**.

## Setting the Aux Out Source

You can choose the source of the Aux Out MMCX connector on the oscilloscope:

- 1 Choose **Main Menu > Utilities > User Options Menu**.
- 2 In the User Options Menu, click **Auxiliary I/O**.
- 3 In the Auxiliary I/O Menu, click **Aux Out** and select from:
  - **Off** – Nothing is output to the Aux Out connector.
  - **Triggers**– Each time the oscilloscope triggers, a rising edge occurs on Aux Out. The rising edge is delayed 30 ns from the oscilloscope's trigger point. The output level is 0-5 V into an open circuit, and 0-2.5 V into 50  $\Omega$ . See [Chapter 9](#), “Triggers,” starting on page 129.
  - **Mask**– The pass/fail status is evaluated periodically. When the evaluation of the testing period results in a failure, the trigger output pulses high (+5 V). Otherwise, the trigger output remains at low (0 V). See [Chapter 14](#), “Mask Testing,” starting on page 235.
  - **Waveform Generator Sync Pulse**– All of the waveform generator output functions (except DC, Noise, and Cardiac) have an associated Sync signal:  
 The Sync signal is a TTL positive pulse that occurs when the waveform rises above zero volts (or the DC offset value).  
 See [Chapter 17](#), “Waveform Generator,” starting on page 261.
  - **Trigger Source**– The raw trigger signal from the oscilloscope's trigger circuit is output to Trig Out. It produces a rising edge whenever the input source would cause a trigger, even though that might occur multiple times within the time of a single acquisition. The trigger source can be a front panel analog input channel or an external trigger input. The output level is 0-5 V into an open circuit, and 0-2.5 V into 50  $\Omega$ . This option is not available in all trigger modes.

The Aux Out connector also provides the User Calibration signal. See ["To perform user calibration"](#) on page 301.

## Enabling Remote Command Logging

When remote command logging is enabled, remote commands sent to the instrument (and results returned by the instrument) can be logged to the screen, to a text file, or to both the screen and a text file.

To enable remote command logging:

- 1 Choose **Main Menu > Utilities > User Options Menu**.
- 2 In the User Options Menu, click **Remote Log** to open the Remote Log Menu:

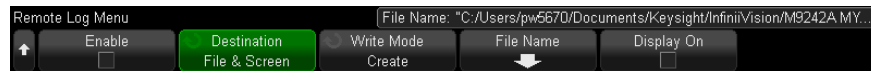

- 3 Click **Enable** to enable or disable the remote command logging feature.

When remote logging is enabled, additional debug information can be included in the returned error string. If the error is detected by the SCPI command parser, such as a header error or other syntax error, the extra debug information is generated and included. But if the error is detected by the oscilloscope system, such as when an out-of-range value is sent, then no extra debug information is included.

- 4 Click **Destination** to select whether remote commands are logged to a text file, logged to the screen, or both.
- 5 Click **Write Mode** to specify whether logged commands will be created in a new list or appended to existing logged commands.

Your selection takes effect when remote command logging is enabled.

This option applies to both screen and file logging.

- 6 Click **File Name** to open the Remote Log Filename Menu where you can specify the name of the file to which remote commands are logged.
- 7 Click **Display On** to enable or disable the screen display of logged remote commands and their return values (if applicable).

## Performing Service Tasks

The Service Menu (choose **Main Menu > Utilities > Service Menu**) lets you perform service-related tasks:



- **"To perform user calibration"** on page 301
- **"To perform hardware self test"** on page 302
- **"To display oscilloscope information"** on page 302
- **"To display the user calibration status"** on page 302

For other information related to oscilloscope maintenance and service, see:

- **"To check warranty and extended services status"** on page 303
- **"To contact Keysight"** on page 303
- **"To return the instrument"** on page 303

### To perform user calibration

Perform user-calibration:

- Every two years or after 4000 hours of operation.
- If the ambient temperature is  $>10^{\circ}\text{C}$  from the calibration temperature.
- If you want to maximize the measurement accuracy.

The amount of use, environmental conditions, and experience with other instruments help determine if you need shorter User Calibration intervals.

User Calibration performs an internal self-alignment routine to optimize the signal path in the oscilloscope. The routine uses internally generated signals to optimize circuits that affect channel sensitivity, offset, and trigger parameters.

Performing User Calibration will invalidate your Certificate of Calibration. If NIST (National Institute of Standards and Technology) traceability is required, perform the "Performance Verification" procedure in the *Service Guide* using traceable sources.

To perform user calibration:

- 1 Disconnect all inputs from the front panel and allow the oscilloscope to warm up before performing this procedure.

A powered-on chassis is not sufficient for the oscilloscope module to reach its operating temperature. The oscilloscope module must be enabled by connecting a driver (like the Soft Front Panel) and running with a default setup for at least 30 minutes to stabilize the operating temperature.

- 2 From the Aux Out output, connect a MMCX-to-BNC cable to a BNC tee adapter.
- 3 From the tee adapter, connect equal length cables to the channel 1 and channel 2 inputs.
- 4 Turn off calibration protection (**Main Menu > Utilities > Service Menu, Cal Protect**).
- 5 Click **Start User Calibration** to begin the user calibration.

## To perform hardware self test

In the Service Menu (choose **Main Menu > Utilities > Service Menu**), clicking **Hard ware Self Test** performs a series of internal procedures to verify that the oscilloscope is operating properly.

It is recommended you run Hardware Self Test:

- After experiencing abnormal operation.
- For additional information to better describe an oscilloscope failure.
- To verify proper operation after the oscilloscope has been repaired.

Successfully passing Hardware Self Test does not guarantee 100% of the oscilloscope's functionality. Hardware Self Test is designed to provide an 80% confidence level that the oscilloscope is operating properly.

## To display oscilloscope information

To display information about your oscilloscope:

- 1 Choose **Main Menu > Help Menu**.
- 2 In the Help Menu, click **About Oscilloscope**. In the resulting dialog box, the following information is displayed:
  - Model number.
  - Serial number.
  - Bandwidth.
  - Module installed.
  - Software version.
  - Installed licenses. See also "**Installing Licenses and Displaying License Information**" on page 306.

## To display the user calibration status

In the Service Menu (choose **Main Menu > Utilities > Service Menu**), clicking **User Calibration Status** displays the summary results of the previous User Calibration, and the status of probe calibrations for probes that can be calibrated. Note that

passive probes do not need to be calibrated, but InfiniiMax probes can be calibrated. For more information about calibrating probes see "[To calibrate a probe](#)" on page 62.

## To check warranty and extended services status

To learn the warranty status of your oscilloscope:

- 1 Point your web browser to: [www.keysight.com/find/warrantystatus](http://www.keysight.com/find/warrantystatus)
- 2 Enter your product's model number and serial number. The system will search for the warranty status of your product and display the results. If the system cannot find your product's warranty status, select **Contact Us** and speak with a Keysight Technologies representative.

## To contact Keysight

Information on contacting Keysight Technologies can be found at: [www.keysight.com/find/contactus](http://www.keysight.com/find/contactus)

## To return the instrument

Before shipping the oscilloscope to Keysight Technologies, contact your nearest Keysight Technologies sales or service office for additional details. Information on contacting Keysight Technologies can be found at:

[www.keysight.com/find/contactus](http://www.keysight.com/find/contactus)

- 1 Write the following information on a tag and attach it to the oscilloscope.
  - Name and address of owner.
  - Model number.
  - Serial number.
  - Description of service required or failure indication.

- 2 Remove accessories from the oscilloscope.

Only return accessories to Keysight Technologies if they are associated with the failure symptoms.

- 3 Package the oscilloscope.

You can use the original shipping container, or provide your own materials sufficient to protect the instrument during shipping.

- 4 Seal the shipping container securely, and mark it FRAGILE.

## Configuring the Quick Action Menu Item

The **Main Menu > Quick Action** menu item lets you perform common, repetitive actions.

To configure the **Main Menu > Quick Action** menu item:

- 1 Choose **Main Menu > Utilities > Quick Action Menu**.
- 2 Click **Action**; then, select the action that should be performed:
  - **Off** – disables the **Main Menu > Quick Action** menu item.
  - **Quick Measure All** – displays a popup containing a snapshot of all the single waveform measurements. The **Source** softkey lets you select the waveform source (which also becomes the source selection in the Add Measurements Menu). See [Chapter 13](#), “Measurements,” starting on page 203.
  - **Quick Measure Statistics Reset** – resets all measurement statistics and the measurement count. See ["Measurement Statistics"](#) on page 233.
  - **Quick Mask Statistics Reset** – resets mask statistics and counters. See ["Mask Statistics"](#) on page 240.
  - **Quick Save** – saves the current image, waveform data, or setup. Click **Settings** to set up the save options. See [Chapter 18](#), “Save/Email/Recall (Setups, Screens, Data),” starting on page 281.
  - **Quick Email** – e-mails the current setup, screen image, or data file. Press **Settings** to set up the e-mail options. See ["Emailing Setups, Screen Images, or Data"](#) on page 289.
  - **Quick Recall** – recalls a setup, mask, or reference waveform. Click **Settings** to set up the recall options. See [Chapter 18](#), “Save/Email/Recall (Setups, Screens, Data),” starting on page 281.
  - **Quick Freeze Display** – freezes the display without stopping running acquisitions or un-freezes the display if currently frozen. For more information, see ["To freeze the display"](#) on page 122.
  - **Quick Trigger Mode** – toggles the trigger mode between Auto and Normal, see ["To select the Auto or Normal trigger mode"](#) on page 170.
  - **Quick Clear Display** – clears the display, see ["To clear the display"](#) on page 116.

Once the **Main Menu > Quick Action** menu item is configured, you simply choose it to perform the selected action.



## 20 Reference

Installing Licenses and Displaying License Information /	306
Software and Firmware Updates /	309
Binary Data (.bin) Format /	310
CSV and ASCII XY files /	317
Acknowledgements /	319

## Installing Licenses and Displaying License Information

Licenses are managed and installed using the Keysight License Manager on the host PC. The licensing process goes like this:

- 1 You order a model number for a licensed upgrade feature.
- 2 You get an entitlement certificate with instructions on how to redeem the license.
- 3 When redeeming the license, you will need the Host ID of the P924xA USB oscilloscope. To get the Host ID:
  - a In the oscilloscope's Soft Front Panel (SFP) user interface, choose **Main Menu > Help Menu**.
  - b In the Help Menu, click **About Oscilloscope**.
  - c In the About This Oscilloscope dialog box, at the end of the Host ID information, click the copy-to-clipboard button:



- d When entering the Host ID information during license redemption, paste it from the clipboard.
- 4 When license redemption is completed, you will receive a \*.lic license file.
- 5 Make sure the P924xA USB oscilloscope is connected to the host PC and powered-on so that the Keysight License Manager can detect the oscilloscope during license installation.

- 6 On the host PC, follow the Keysight License Manager instructions for installing from a license file. (The Add New License button uses a different process than installing from a license file.)

After installation, the new license is listed in the About This Oscilloscope dialog box along with the other **Installed Licenses**.

For more information about the licenses and other oscilloscope options available, see:

- ["Licensed Options Available"](#) on page 307
- ["Other Options Available"](#) on page 308

## Licensed Options Available

The following licensed options can be easily installed without returning the oscilloscope to a Service Center. See data sheets for details.

**Table 5** Licensed Options Available

License	Description	Upgrade model number, notes
AERO	MIL-STD-1553 and ARINC 429 Serial Triggering and Analysis.	Order P9240AROA.
AUTO	Automotive Serial Triggering and Analysis (CAN, LIN).	Order P9240ATOA.
CANFD	Automotive Serial Triggering and Analysis (CAN-FD).	Order P9240ATOA.
COMP	Computer Serial Triggering and Analysis (RS232/422/485/UART). Provides trigger and decode capability for many UART (Universal Asynchronous Receiver/Transmitter) protocols including RS232 (Recommended Standard 232).	Order P9240CMPA.
CXPI	CXPI (Clock Extension Peripheral Interface) Serial Triggering and Analysis.	Order P9240CXPA.
EMBD	Embedded Serial Triggering and Analysis (I2C).	Order P9240EMBA.
FRA	Frequency Response Analysis.	Order P9240FRAA.
MASK	Mask Limit Test Lets you create a mask and test waveforms to determine whether they comply to the mask.	Order P9240MSKA.
NFC	Near Field Communication (NFC) Trigger.	Order P9240NFCA.
NRZ	Manchester/NRZ (Non Return to Zero) Triggering and Analysis.	Order P9240NRZA.
SENSOR	SENT (Single Edge Nibble Transmission) Triggering and Analysis.	Order P9240SNSA.
USBPD	USB PD (Power Delivery) Serial Triggering and Decode.	Order P9240UPDA.

**Table 5** Licensed Options Available (continued)

License	Description	Upgrade model number, notes
VID	Extended Video Triggering and Analysis.	Order P9240VIDA.
WAVEGEN	Waveform Generator.	Order P9240AWGA.

## Other Options Available

**Table 6** Calibration Option

Option	Order
A6J	ANSI Z540 Compliant Calibration

## Software and Firmware Updates

From time to time Keysight Technologies releases software and firmware updates for its products. To search for firmware updates for your oscilloscope, direct your web browser to [www.keysight.com/support/P9241](http://www.keysight.com/support/P9241).

To view the currently installed software and firmware, see "[To display oscilloscope information](#)" on page 302.

## Binary Data (.bin) Format

The binary data format stores waveform data in binary format and provides data headers that describe that data.

Because the data is in binary format, the size of the file is approximately 5 times smaller than the ASCII XY format.

If more than one source is on, all displayed sources will be saved, except math functions.

When using segmented memory, each segment is treated as a separate waveform. All segments for a channel are saved, then all segments of the next (higher numbered) channel are saved. This continues until all displayed channels are saved.

When the oscilloscope is in the Peak Detect acquisition mode, the minimum and maximum value waveform data points are saved to the file in separate waveform buffers. The minimum value data points are saved first; then, the maximum value data points are saved.

### BIN data - using segmented memory

When saving all segments, each segment has its own waveform header (see **"Binary Header Format"** on page 311).

In BIN file format, data are presented as follows:

- Channel 1 data (all segments)
- Channel 2 data (all segments)
- Channel 3 data (all segments)
- Channel 4 data (all segments)
- Digital channel data (all segments)
- Math waveform data (all segments)

When not saving all segments, the number of waveforms is equivalent to the number of active channels (including math and digital channels, with up to seven waveforms for each digital pod). When saving all segments, the number of waveforms is equal to the number of active channels multiplied by the number of segments acquired.

## Binary Data in MATLAB

Binary data from an InfiniiVision oscilloscope can be imported to The MathWorks MATLAB. You can download the appropriate MATLAB functions from the Keysight Technologies web site at [www.keysight.com/find/P924x-examples](http://www.keysight.com/find/P924x-examples).

Keysight provides the .m files, which need to be copied into the work directory for MATLAB. The default work directory is C:\MATLAB7\work.

## Binary Header Format

**File Header** There is only one file header in a binary file. The file header consists of the following information.

Cookie	Two byte characters, AG, that indicate the file is in the Keysight Binary Data file format.
Version	Two bytes that represent the file version.
File Size	A 32-bit integer that is the number of bytes that are in the file.
Number of Waveforms	A 32-bit integer that is the number of waveforms that are stored in the file.

**Waveform Header** It is possible to store more than one waveform in the file, and each waveform stored will have a waveform header. When using segmented memory, each segment is treated as a separate waveform. The waveform header contains information about the type of waveform data that is stored following the waveform data header.

Header Size	A 32-bit integer that is the number of bytes in the header.
Waveform Type	A 32-bit integer that is the type of waveform stored in the file: <ul style="list-style-type: none"> <li>▪ 0 = Unknown.</li> <li>▪ 1 = Normal.</li> <li>▪ 2 = Peak Detect.</li> <li>▪ 3 = Average.</li> <li>▪ 4 = Not used in InfiniiVision oscilloscopes.</li> <li>▪ 5 = Not used in InfiniiVision oscilloscopes.</li> <li>▪ 6 = Logic.</li> </ul>
Number of Waveform Buffers	A 32-bit integer that is the number of waveform buffers required to read the data.
Points	A 32-bit integer that is the number of waveform points in the data.
Count	A 32-bit integer that is the number of hits at each time bucket in the waveform record when the waveform was created using an acquisition mode like averaging. For example, when averaging, a count of four would mean every waveform data point in the waveform record has been averaged at least four times. The default value is 0.
X Display Range	A 32-bit float that is the X-axis duration of the waveform that is displayed. For time domain waveforms, it is the duration of time across the display. If the value is zero then no data has been acquired.

X Display Origin	A 64-bit double that is the X-axis value at the left edge of the display. For time domain waveforms, it is the time at the start of the display. This value is treated as a double precision 64-bit floating point number. If the value is zero then no data has been acquired.
X Increment	A 64-bit double that is the duration between data points on the X axis. For time domain waveforms, this is the time between points. If the value is zero then no data has been acquired.
X Origin	A 64-bit double that is the X-axis value of the first data point in the data record. For time domain waveforms, it is the time of the first point. This value is treated as a double precision 64-bit floating point number. If the value is zero then no data has been acquired.
X Units	A 32-bit integer that identifies the unit of measure for X values in the acquired data: <ul style="list-style-type: none"> <li>▪ 0 = Unknown.</li> <li>▪ 1 = Volts.</li> <li>▪ 2 = Seconds.</li> <li>▪ 3 = Constant.</li> <li>▪ 4 = Amps.</li> <li>▪ 5 = dB.</li> <li>▪ 6 = Hz.</li> </ul>
Y Units	A 32-bit integer that identifies the unit of measure for Y values in the acquired data. The possible values are listed above under X Units.
Date	A 16-byte character array, left blank in InfiniiVision oscilloscopes.
Time	A 16-byte character array, left blank in the InfiniiVision oscilloscopes.
Frame	A 24 byte character array that is the model number and serial number of the oscilloscope in the format of: MODEL#:SERIAL#.
Waveform Label	A 16 byte character array that contains the label assigned to the waveform.
Time Tags	A 64-bit double, only used when saving multiple segments (requires segmented memory option). This is the time (in seconds) since the first trigger.
Segment Index	A 32-bit unsigned integer. This is the segment number. Only used when saving multiple segments.

### Waveform Data Header

A waveform may have more than one data set. Each waveform data set will have a waveform data header. The waveform data header consists of information about the waveform data set. This header is stored immediately before the data set.



Waveform Data Header Size	A 32-bit integer that is the size of the waveform data header.
Buffer Type	A 16-bit short that is the type of waveform data stored in the file: <ul style="list-style-type: none"> <li>▪ 0 = Unknown data.</li> <li>▪ 1 = Normal 32-bit float data.</li> <li>▪ 2 = Maximum float data.</li> <li>▪ 3 = Minimum float data.</li> <li>▪ 4 = Not used in InfiniiVision oscilloscopes.</li> <li>▪ 5 = Not used in InfiniiVision oscilloscopes.</li> <li>▪ 6 = Digital unsigned 8-bit char data (for digital channels).</li> </ul>
Bytes Per Point	A 16-bit short that is the number of bytes per data point.
Buffer Size	A 32-bit integer that is the size of the buffer required to hold the data points.

### Example Program for Reading Binary Data

To find an example program for reading binary data, direct your web browser to [www.keysight.com/find/P924x-examples](http://www.keysight.com/find/P924x-examples), and select "Example Program for Reading Binary Data".

### Examples of Binary Files

#### Single Acquisition Multiple Analog Channels

The following picture shows a binary file of a single acquisition with multiple analog channels.

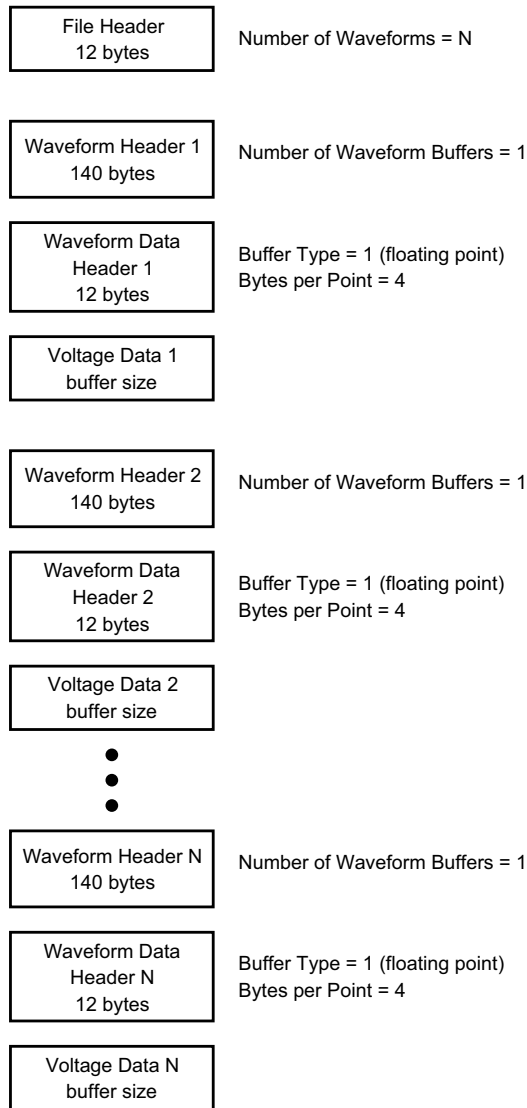

**Single Acquisition  
All Pods Logic  
Channels**

The following picture shows a binary file of a single acquisition with all pods for the logic channels saved.

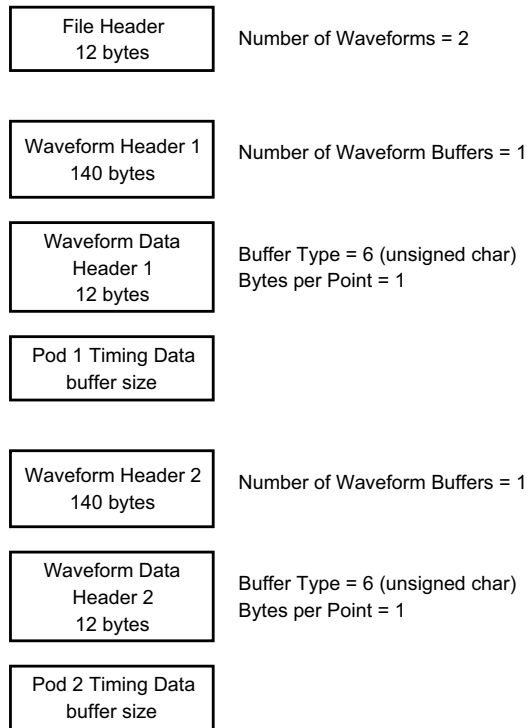

### Segmented Memory Acquisition on One Analog Channel

The following picture shows a binary file of a segmented memory acquisition on one analog channel.

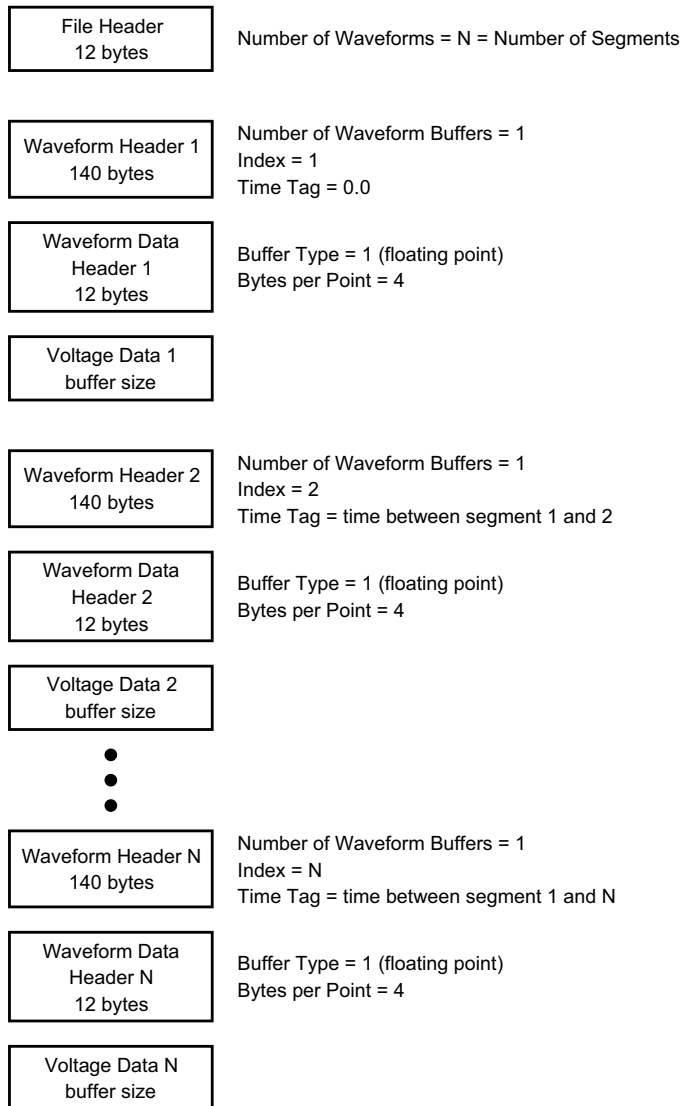

## CSV and ASCII XY files

- ["CSV and ASCII XY file structure"](#) on page 317
- ["Minimum and Maximum Values in CSV Files"](#) on page 317
- ["Frequency Data in CSV Files"](#) on page 318

### CSV and ASCII XY file structure

In CSV or ASCII XY format the **Length** control selects the number of points per segment. All segments are contained in the CSV file or in each ASCII XY data file.

For example: If the Length control is set to 1000 points, there will be 1000 points (rows in the spreadsheet) per segment. When saving all segments there are three header rows, so the data for the first segment starts at row 4. The second segment's data starts at row 1004. The time column shows the time since the trigger on the first segment. The top row shows the selected number of points per segment.

BIN files are a more efficient data transfer format than CSV or ASCII XY. Use this file format for fastest data transfer.

### Minimum and Maximum Values in CSV Files

If you are running a Minimum or Maximum measurement, the minimum and maximum values shown in the measurement display may not appear in the CSV file.

**Explanation:** When the oscilloscope's sample rate is 4 GSa/s, a sample will be taken every 250 ps. If the horizontal scale is set to 10 us/div, there will be 100 us of data displayed (because there are ten divisions across the screen). To find the total number of samples the oscilloscope will take:

$$100 \text{ us} \times 4 \text{ GSa/s} = 400\text{K samples}$$

The oscilloscope is required to display those 400K samples using 640 pixel columns. The oscilloscope will decimate the 400K samples to 640 pixel columns, and this decimation keeps track of the min and max values of all the points that are represented by any given column. Those min and max values will be displayed in that screen column.

A similar process is used to reduce the acquired data to produce a record usable for various analysis needs such as measurements and CSV data. This analysis record (or *measurement record*) is much larger than 640 and may in fact contain up to 65536 points. Still, once the # of acquired points > 65536, some form of decimation is required. The decimator used to produce a CSV record is configured to provide a best-estimate of all the samples that each point in the record represents. Therefore, the min and max values may not appear in the CSV file.

## Frequency Data in CSV Files

When data for multiple frequency sources is saved to a CSV file, this data is saved as one set (with multiple columns) using a horizontal (X) range that covers all sources.

## Acknowledgements

**Table 7** Third Party Software

Software	Description and Copyright	License <sup>1</sup>
7-zip	Copyright (C) 1999-2016 Igor Pavlov.	GNU LGPL + unRAR restriction
Boost Libraries	Copyright © 2008 Beman Dawes, Rene Rivera	Boost Software License (BSL-1.0)
HDF5	HDF5 was developed by <b>The HDF Group</b> and by the National Center for Supercomputing Applications at the University of Illinois at Urbana-Champaign. Copyright 2006-2016 by The HDF Group. Copyright 1998-2006 by the Board of Trustees of the University of Illinois.	BSD-style open source
libpng	Copyright (c) 1998-2002,2004,2006-2016 Glenn Randers-Pehrson (Version 0.96 Copyright (c) 1996, 1997 Andreas Dilger) (Version 0.88 Copyright (c) 1995, 1996 Guy Eric Schalnat, Group 42, Inc.)	libpng specific
TCLAP	Copyright (c) 2003 Michael E. Smoot	MIT License
zlib	Copyright (C) 1995-2013 Jean-loup Gailly and Mark Adler	zlib license
<sup>1</sup> These licenses are located on the Keysight InfiniiVision oscilloscopes manuals CD-ROM.		





# 21 CAN/LIN Triggering and Serial Decode

- Setup for CAN/CAN FD Signals / 322
- Loading and Displaying CAN Symbolic Data / 325
- CAN/CAN FD Triggering / 326
- CAN/CAN FD Serial Decode / 329
- Setup for LIN Signals / 334
- Loading and Displaying LIN Symbolic Data / 336
- LIN Triggering / 337
- LIN Serial Decode / 339

CAN/LIN triggering and serial decode requires the AUTO license that you can get by purchasing the P9240ATOA upgrade.

## Setup for CAN/CAN FD Signals

Setup consists of connecting the oscilloscope to a CAN signal, using the Signals Menu to specify the signal source, threshold voltage level, baud rate, and sample point.

Connect the oscilloscope to a CAN signal that has a dominant-low polarity. If you are connecting to the CAN signal using a differential probe, connect the probe's positive lead to the dominant-low CAN signal and connect the negative lead to the dominant-high CAN signal.

To set up the oscilloscope to capture CAN signals:

- 1 Choose **Main Menu > Analyze > Serial Decode**.
- 2 Click the **Serial** softkey, select Serial 1 or Serial 2, and click the softkey again to enable decode.
- 3 Click the **Mode** softkey; then, select **CAN**.
- 4 Click the **Signals** softkey to open the CAN Signals Menu.

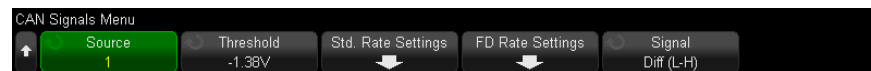

- 5 Click **Source**; then, select the channel for the CAN signal.  
The label for the CAN source channel is automatically set.
- 6 Click the **Threshold** softkey; then, enter the CAN signal threshold voltage level.  
The threshold voltage level is used in decoding, and it will become the trigger level when the trigger type is set to the selected serial decode slot.
- 7 Click the **Std. Rate Settings** softkey to open the CAN Standard Rate Settings Menu.

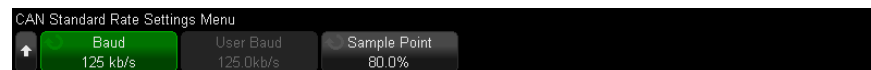

- a Click the **Baud** softkey; then, select the baud rate that matches match your CAN bus signal.

The CAN baud rate can be set to predefined baud rates from 10 kb/s up to 5 Mb/s or a user-defined baud rate from 10.0 kb/s to 4 Mb/s in increments of 100 b/s. Fractional user-defined baud rates between 4 Mb/s and 5 Mb/s are not allowed.

The default baud rate is 125 kb/s

If none of the pre-defined selections match your CAN bus signal, select **User Defined**; then, click the **User Baud** softkey and enter the baud rate.

- b Click the **Sample Point** softkey; then, select the point between phase segments 1 and 2 where the state of the bus is measured. This controls the point within the bit's time where the bit value is captured.

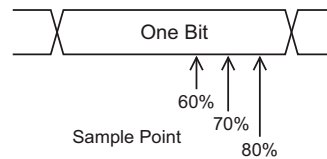

- c Click the  Back/Up softkey to return to the CAN Signals Menu.
- 8 When decoding CAN FD, click the **FD Rate Settings** softkey to open the CAN FD Rate Settings Menu.

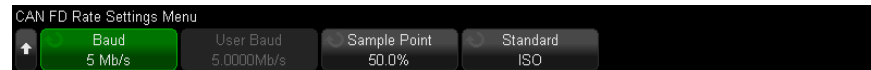

## NOTE

For standard CAN, only the Standard Rate Settings must be set correctly. For CAN FD, both the Standard Rate Settings and the FD Rate Settings must be set correctly.

- a Click the **Baud** softkey; then, match the CAN FD baud rate of the signal from your device under test.

If the desired baud rate is not shown in the list, select **User Defined** and use the **User Baud** softkey to set the baud rate.

The CAN FD baud rate can be set to predefined baud rates from 1-10 Mb/s or a user-defined baud rate from 10.0 kb/s to 10 Mb/s in increments of 100 b/s.

If the baud rate you select does not match the CAN FD baud rate, false triggers and decoding may occur.

- b Click the **Sample Point** softkey; then, select the sample point.

The sample point is the point during the bit time where the bit level is sampled to determine whether it is dominant or recessive. The sample point represents the percentage of time between the beginning of the bit time to the end of the bit time.

You may need to adjust the sample point to get a reliable trigger and decode, depending on your CAN FD network topology and where the oscilloscope probe is located in the network.

- c Click the **Standard** softkey to select the standard that will be used when decoding or triggering on FD frames, ISO, or non-ISO.

This setting has no effect on the processing of non-FD (classical) frames.

- d Click the  Back/Up softkey to return to the CAN Signals Menu.

- 9 Click the **Signal** softkey and select the type and polarity of the CAN signal. This also automatically sets the channel label for the source channel.

- **CAN\_H** – The actual CAN\_H differential bus.
- **Differential (H-L)** – The CAN differential bus signals connected to an analog source channel using a differential probe. Connect the probe's positive lead to the dominant-high CAN signal (CAN\_H) and connect the negative lead to the dominant-low CAN signal (CAN\_L).

Dominant low signals:

- **Rx** – The Receive signal from the CAN bus transceiver.
- **Tx** – The Transmit signal from the CAN bus transceiver.
- **CAN\_L** – The actual CAN\_L differential bus signal.
- **Differential (L-H)** – The CAN differential bus signals connected to an analog source channel using a differential probe. Connect the probe's positive lead to the dominant-low CAN signal (CAN\_L) and connect the negative lead to the dominant-high CAN signal (CAN\_H).

## Loading and Displaying CAN Symbolic Data

When you load (recall) a CAN DBC communication database (\*.dbc) file into the oscilloscope, its symbolic information can be:

- Displayed in the decode waveform and Lister window.
- Used when setting up CAN triggering.
- Used when searching for CAN data in the decode.

To recall a DBC file into the oscilloscope:

- 1 Choose **Main Menu > File > Recall Menu**.
- 2 In the Recall Menu, click **Recall:**, then, select **CAN Symbolic data (\*.dbc)**.
- 3 Click **Press to go** and navigate to the DBC file.
- 4 Click **Load to:** and select which serial decode (**S1** or **S2**) the symbolic information will be used with.
- 5 Click **Press to Recall**.

The DBC file remains in the oscilloscope until it is overwritten or a secure erase is performed.

To display CAN symbolic data:

- 1 Choose **Main Menu > Analyze > Serial Decode**.
- 2 Click the **Display** softkey and select **Symbolic** (instead of **Hexadecimal**).

Your choice affects both the decode waveform and the Lister window.

### NOTE

For CAN FD frames, symbolic decoding is limited to the first eight bytes.

## CAN/CAN FD Triggering

To set up the oscilloscope to capture a CAN signal, see "[Setup for CAN/CAN FD Signals](#)" on page 322.

The Controller Area Network (CAN) trigger allows triggering on CAN version 2.0A, 2.0B, and CAN FD (Flexible Data-rate) signals.

A CAN message frame in CAN\_L signal type is shown below:



After setting up the oscilloscope to capture a CAN signal:

- 1 Choose **Main Menu > Trigger > Trigger Menu**.
- 2 In the Trigger Menu, click the **Trigger Type** softkey; then, select Serial 1 or Serial 2 on which the CAN signal is being decoded.



- 3 Click the **Trigger on:** softkey; then, select the trigger condition:
  - **SOF - Start of Frame** – triggers at the start bit for both data and overload frames.
  - **EOF - End of Frame** – triggers at the end of any frame. \*
  - **Frame ID** – triggers on any standard CAN (data or remote) or CAN FD frame at the end of the 11- or 29-bit ID field.
  - **Data Frame ID (non-FD)** – triggers on standard CAN data frames at the end of the 11- or 29-bit ID field.
  - **Data Frame ID and Data (non-FD)** – triggers on any standard CAN data frame at the end of the last data byte defined in the trigger. The DLC of the packet must match the number of bytes specified.
  - **Data Frame ID and Data (FD)** – triggers on CAN FD frames at the end of the last data byte defined in the trigger. You can trigger on up to 8 bytes of data anywhere within the CAN FD data, which can be up to 64 bytes long.
  - **Remote Frame ID** – triggers on standard CAN remote frames at the end of the 11- or 29-bit ID field.
  - **Error Frame** – triggers after 6 consecutive 0s while in a data frame, at the EOF. \*

- **Acknowledge Error** – triggers on the acknowledge bit if the polarity is incorrect. \*
- **Form Error** – triggers on reserved bit errors. \*
- **Stuff Error** – triggers on 6 consecutive 1s or 6 consecutive 0s, while in a non-error or non overload frame. \*
- **CRC Field Error** – triggers when the calculated CRC does not match the transmitted CRC. In addition, for FD frames, will also trigger if the Stuff Count is in error. \*
- **Spec Error (Ack or Form or Stuff or CRC)** – triggers on Ack, Form, Stuff, or CRC errors. \*
- **All Errors** – triggers on all Spec errors and error frames. \*
- **BRS Bit (FD)** – triggers on the BRS bit of CAN FD frames. \*
- **CRC Delimiter Bit (FD)** – triggers on the CRC delimiter bit in CAN FD frames. \*
- **ESI Bit Active (FD)** – triggers on the ESI bit if set active. \*
- **ESI Bit Passive (FD)** – triggers on the ESI bit if set passive. \*
- **Overload Frame** – triggers on an overload frame.

\* You can optionally qualify the trigger for frames whose ID you specify.

When CAN symbolic data is loaded into the oscilloscope (see "**Loading and Displaying CAN Symbolic Data**" on page 325), you can trigger on:

- **Message** – a symbolic message.
- **Message and Signal (non-FD)** – a symbolic message and a signal value.
- **Message and Signal (FD, first 8 bytes only)** – a symbolic message and a signal value, limited to the first 8 bytes of FD data.

Symbolic messages, signals, and values are defined in the DBC communication database file.

A message is the symbolic name for a CAN frame ID, a signal is the symbolic name for a bit or set of bits within the CAN data, and a value can be a symbolic representation of the signal bit values or it can be a decimal number with units.

- 4 If you select a condition that lets you qualify by ID or trigger on ID or data values, use the **Filter by ID** softkey, or the **Bits** softkey and the CAN Bits Menu, and the remaining softkeys to specify those values.

For details about using the remaining softkeys to enter values, click and hold the mouse button over the softkey in question to display the built-in help.

You can use the **Zoom** mode for easier navigation of the decoded data.

#### NOTE

If the setup does not produce a stable trigger, the CAN signal may be slow enough that the oscilloscope is AutoTriggering. Click the Run/Stop status in the upper-right corner of the display, and change the trigger mode from **Auto** to **Normal**.

**NOTE**

To display CAN serial decode, see "[CAN/CAN FD Serial Decode](#)" on page 329.

---



## CAN/CAN FD Serial Decode

To set up the oscilloscope to capture CAN signals, see ["Setup for CAN/CAN FD Signals"](#) on page 322.

### NOTE

For CAN triggering set up see ["CAN/CAN FD Triggering"](#) on page 326.

To set up CAN serial decode:

- 1 Choose **Main Menu > Analyze > Serial Decode** to display the Serial Decode Menu.



- 2 If the decode line does not appear on the display, choose **Main Menu > Analyze > Serial Decode** again to turn it on.
- 3 If the oscilloscope is stopped, choose **Main Menu > Run/Stop** to acquire and decode data.

### NOTE

If the setup does not produce a stable trigger, the CAN signal may be slow enough that the oscilloscope is AutoTriggering. Click the Run/Stop status in the upper-right corner of the display, and change the trigger mode from **Auto** to **Normal**.

You can use the horizontal **Zoom** window for easier navigation of the decoded data.

- See Also
- ["Interpreting CAN/CAN FD Decode"](#) on page 330
  - ["CAN Totalizer"](#) on page 331
  - ["Interpreting CAN Lister Data"](#) on page 332
  - ["Searching for CAN Data in the Lister"](#) on page 333

## Interpreting CAN/CAN FD Decode

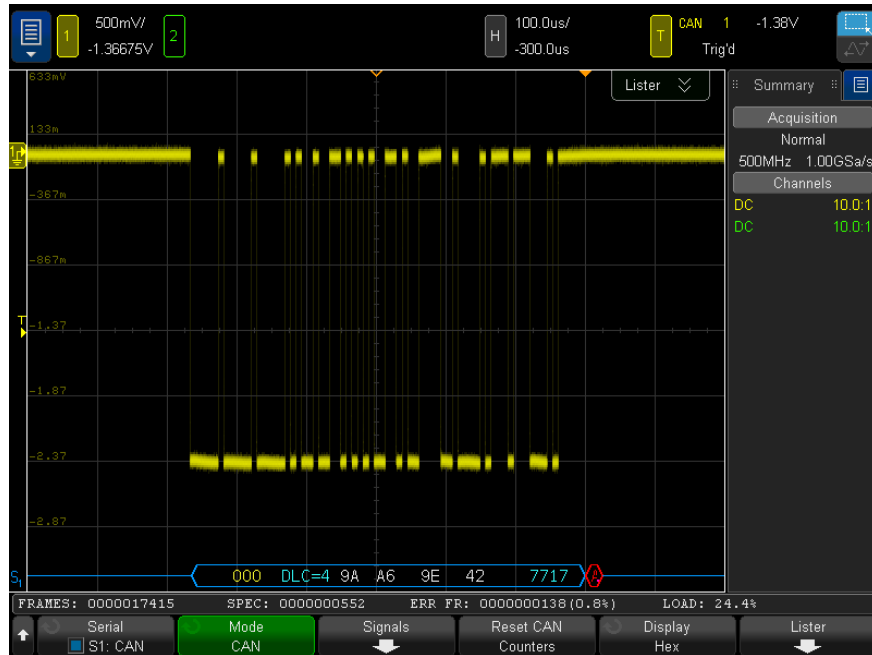

The CAN decode display is color coded as follows:

- Blue angled waveforms show an active bus (inside a packet/frame).
- Blue mid-level lines show an idle bus.
- Frame ID – yellow.
- Data bytes – white hex digits.
- CAN frame type and Data Length Code (DLC) – blue for data frames, green for remote frames. The DLC is always a decimal value. CAN frame types can be:
  - FD – a CAN FD frame whose bit rate does not switch during the data phase.
  - BRS – a CAN FD frame whose bit rate switches during the data phase.
  - RMT – a standard CAN remote frame.
  - Data – a standard CAN data frame.

The status of the Error State Indicator (ESI) flag is shown in the "Type" column of the Lister. If the ESI bit is recessive, indicating error passive, the background of the "Type" column will be yellow. If the ESI bit indicates error active, the "Type" column's background will be unshaded.

The DLC field will always be displayed in decimal, and will indicate the number of bytes in the frame. So for example, for an FD frame that has the DLC code 0xF, which represents a packet with 64 bytes, "DLC=64" will be displayed on the decode line, and "64" will be displayed in the DLC column of the Lister.

- Overload frame – blue with the text "OVRD". An overload condition may occur before an end of frame condition. If so, the frame is closed and opened with blue brackets at the start of the overload condition.
- Stuff Count – green hex digit when valid, red when error detected. The hex digit shows the gray-coded with parity bit stuff count.
- CRC – blue hex digits when valid, red when error detected.
- Red angled waveforms – Unknown or error condition.
- Flagged error frames – red with "ERR FRAME", "STUFF ERR", "FORM ERR", "ACK ERR", "GLITCH ERR", or "?" (unknown).
- Pink vertical bars – Expand horizontal scale (and run again) to see decode.
- Red Dot – More information is available. Decoded text is truncated to fit. Expand the horizontal scale to view the information.

## CAN Totalizer

The CAN totalizer provides a direct measure of bus quality and efficiency. The CAN totalizer measures total CAN frames, Specification error counter, flagged error frames, and bus utilization.



The totalizer is always running (counting frames and calculating percentages) and is displayed whenever CAN decode is displayed. The totalizer counts even when the oscilloscope is stopped (not acquiring data). Stopping acquisitions does not affect the totalizer. When an overflow condition occurs, the counter displays **OVERFLOW**. The counters can be reset to zero by clicking the **Reset CAN Counters** softkey.

### Types of Frames

- Active error frames are CAN frames in which a CAN node recognizes an error condition during a data or remote frame and issues an active error flag.
- A partial frame occurs when the oscilloscope detects any error condition during a frame that is not followed by an active error flag. Partial frames are not counted.

### Counters

- The FRAMES counter gives the total number of completed remote, data, overload, and active error frames.
- The SPEC counter gives the total number of Specification errors. This counter tracks the number of Acknowledge, Form, Stuff, and CRC errors. If a packet has more than one type of error, that packet will increment the counter by the total number of errors in the packet.
- The ERR FR counter gives the total number of completed active error frames and their percentage of the total number of frames.

- The LOAD (bus load) indicator measures the percentage of time the bus is active. The calculation is done on 330 ms periods, approximately every 400 ms.

Example: If a data frame contains an active error flag, both the FRAMES counter and the ERR FR counter will be incremented. If a data frame contains an error that is not an active error it is considered a partial frame and no counters are incremented.

## Interpreting CAN Lister Data

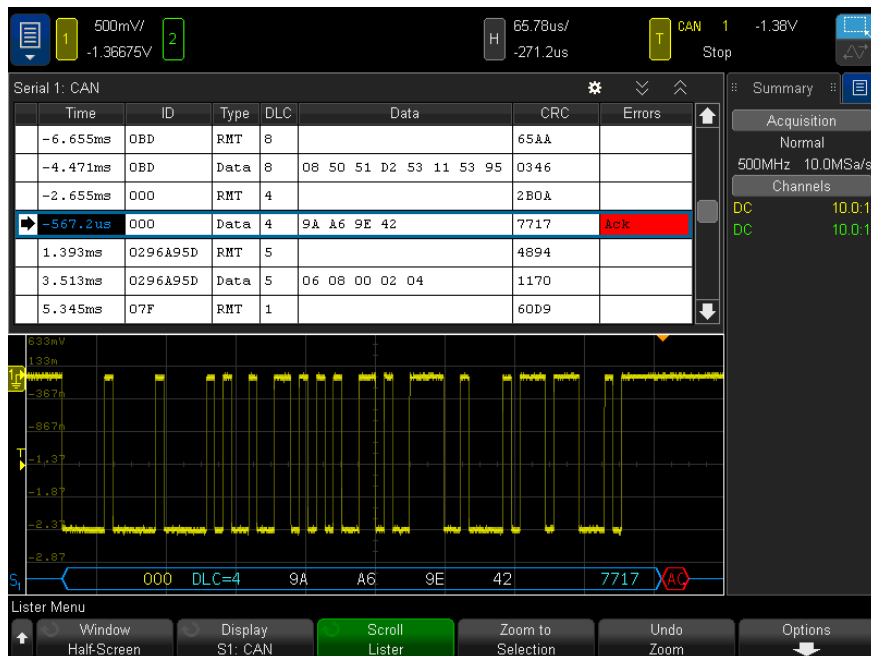

In addition to the standard Time column, the CAN Lister contains these columns:

- ID – frame ID. Can be displayed as hex digits or symbolic information (see ["Loading and Displaying CAN Symbolic Data"](#) on page 325).
- Type – frame type (RMT remote frame or Data).
- DLC – data length code.
- Data – data bytes. Can be displayed as hex digits or symbolic information.
- CRC – cyclic redundancy check.
- Errors – highlighted in red. Errors can be Acknowledge (Ack, A), Form (Fo), or Frame (Fr). Different kinds of errors can be combined like "Fo,Fr" in the above example.

Aliased data is highlighted in pink. When this happens, decrease the horizontal time/div setting and run again.

## Searching for CAN Data in the Lister

The oscilloscope's search capability lets you search for (and mark) certain types of CAN data in the Lister. You can use the sidebar **Navigate** controls to navigate through the marked rows.

- 1 With CAN selected as the serial decode mode, choose **Main Menu > Analyze > Waveform Search**.
- 2 In the Search Menu, click the **Search** softkey; then, select Serial 1 or Serial 2 on which the CAN signal is being decoded.
- 3 Click **Search for**; then, select from these options:
  - **Frame ID** – Finds remote or data frames matching the specified ID.
  - **Data Frame ID** – Finds data frames matching the specified ID.
  - **Data Frame ID and Data** – Finds data frames matching the specified ID and data.
  - **Remote Frame ID** – Finds remote frames with the specified ID.
  - **Error Frame** – Finds CAN active error frames.
  - **Acknowledge Error** – Finds the acknowledge bit if the polarity is incorrect.
  - **Form Error** – Finds reserved bit errors.
  - **Stuff Error** – Finds 6 consecutive 1s or 6 consecutive 0s, while in a non-error or non overload frame.
  - **CRC Field Error** – Finds when the calculated CRC does not match the transmitted CRC.
  - **All Errors** – Finds any form error or active error.
  - **Overload Frame** – Finds CAN overload frames.

When CAN symbolic data is loaded into the oscilloscope (see "[Loading and Displaying CAN Symbolic Data](#)" on page 325), you can search for:

- **Message** – a symbolic message.
- **Message and Signal** – a symbolic message and a signal value.

For more information on searching data, see "[Searching Lister Data](#)" on page 109.

For more information on using the sidebar **Navigate** controls, see "[Navigating the Time Base](#)" on page 49.

## Setup for LIN Signals

LIN (Local Interconnect Network) signal setup consists of connecting the oscilloscope to a serial LIN signal, specifying the signal source, threshold voltage level, baud rate, sample point, and other LIN signal parameters.

To set up the oscilloscope to capture LIN signals:

- 1 Choose **Main Menu > Analyze > Serial Decode**.
- 2 Click the **Serial** softkey, select Serial 1 or Serial 2, and click the softkey again to enable decode.
- 3 Click the **Mode** softkey; then, select **LIN**.
- 4 Click the **Signals** softkey to open the LIN Signals Menu.



- 5 Click the **Source** softkey to select the channel connected to the LIN signal line.

The label for the LIN source channel is automatically set.

- 6 Click the **Threshold** softkey; then, set the LIN signal threshold voltage level to the middle of the LIN signal.

The threshold voltage level is used in decoding, and it will become the trigger level when the trigger type is set to the selected serial decode slot.

- 7 Click the **Baud Rate** softkey to open the LIN Baud Rate Menu.
- 8 Click the **Baud** softkey; then, select the baud rate that matches match your LIN bus signal.

The default baud rate is 19.2 kb/s.

If none of the pre-defined selections match your LIN bus signal, select **User Defined**; then, click the **User Baud** softkey and enter the baud rate.

You can set the LIN baud rate from 2.4 kb/s to 625 kb/s in increments of 100 b/s.

- 9 Click the  Back/Up softkey to return to the LIN Signals Menu.
- 10 Click the **Sample Point** softkey; then, select the sample point at which the oscilloscope will sample the bit value.

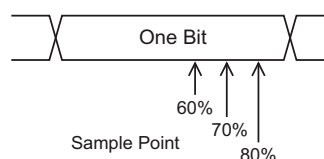

11 Click the **Standard** softkey; then, select the LIN standard you are measuring:

- **LIN 1.3**
- **LIN 1.3 (no length control)** – Select this for systems where length control is not used and all nodes have knowledge of the data packet size. In LIN 1.3, the ID may or may not be used to indicate the number of bytes. (In LIN 2.X, there is no length control.)
- **LIN 2.X**

For LIN 1.2 signals, use the LIN 1.3 setting. The LIN 1.3 setting assumes the signal follows the "Table of Valid ID Values" as shown in section A.2 of the LIN Specification dated December 12, 2002. If your signal does not comply with the table, use the LIN 2.X setting.

12 Click the **Sync Break** softkey and select the minimum number of clocks that define a sync break in your LIN signal.

## Loading and Displaying LIN Symbolic Data

When you load (recall) a LIN description file (\*.ldf) into the oscilloscope, its symbolic information can be:

- Displayed in the decode waveform and Lister window.
- Used when setting up LIN triggering.
- Used when searching for LIN data in the decode.

To recall a LIN description file into the oscilloscope:

- 1 Choose **Main Menu > File > Recall Menu**.
- 2 In the Recall Menu, click **Recall:**, then, select **LIN Symbolic data (\*.ldf)**.
- 3 Click **Press to go** and navigate to the LIN description file.
- 4 Click **Load to:** and select which serial decode (**S1** or **S2**) the symbolic information will be used with.
- 5 Click **Press to Recall**.

The LIN description file remains in the oscilloscope until it is overwritten or a secure erase is performed.

To display LIN symbolic data:

- 1 Choose **Main Menu > Analyze > Serial Decode**.
- 2 Click the **Display** softkey and select **Symbolic** (instead of **Hexadecimal**).

Your choice affects both the decode waveform and the Lister window.



## LIN Triggering

To set up the oscilloscope to capture a LIN signal, see "[Setup for LIN Signals](#)" on page 334.

LIN triggering can trigger on the rising edge at the Sync Break exit of the LIN single-wire bus signal (that marks the beginning of the message frame), the Frame ID, or the Frame ID and Data.

A LIN signal message frame is shown below:

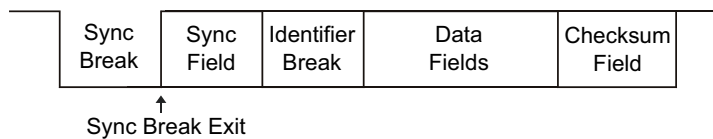

- 1 Choose **Main Menu > Trigger > Trigger Menu**.
- 2 In the Trigger Menu, click the **Trigger Type** softkey; then, select Serial 1 or Serial 2 on which the LIN signal is being decoded.



- 3 Click the **Trigger on:** softkey; then, select the trigger condition:
  - **Sync** (Sync Break) – The oscilloscope triggers on the rising edge at the Sync Break exit of the LIN single-wire bus signal that marks the beginning of the message frame.
  - **ID** (Frame ID) – The oscilloscope triggers when a frame with an ID equal to the selected value is detected. Enter the value for the Frame ID.
  - **ID & Data** (Frame ID and Data) – The oscilloscope triggers when a frame with an ID and data equal to the selected values is detected. When triggering on a frame ID and data:
    - To enter the frame ID value, click the **Frame ID** softkey.  
Note that you can enter a "don't care" value for the frame ID and trigger on data values only.
    - To set up the number of data bytes and enter their values (in hexadecimal or binary), use the remaining softkeys.
  - **Parity Error** – The oscilloscope triggers on parity errors.
  - **Checksum Error** – The oscilloscope triggers on checksum errors.

When a LIN description file (\*.ldf) is loaded (recalled) into the oscilloscope (see "[Loading and Displaying LIN Symbolic Data](#)" on page 336), you can trigger on:

- **Frame (Symbolic)** – a symbolic frame value.

- **Frame and Signal** – a symbolic frame value and a signal value.

Symbolic frames, signals, and values are defined in the LIN description file.

A frame is the symbolic name for a LIN frame ID, a signal is the symbolic name for a bit or set of bits within the LIN data, and a value can be a symbolic representation of the signal bit values or it can be a decimal number with units.

**NOTE**

For details about using the LIN Bits Menu softkeys, click and hold the mouse button over the softkey in question to display the built-in help.

**NOTE**

For LIN decode information see "[LIN Serial Decode](#)" on page 339.

## LIN Serial Decode

To set up the oscilloscope to capture LIN signals, see ["Setup for LIN Signals"](#) on page 334.

### NOTE

For LIN triggering setup see ["LIN Triggering"](#) on page 337.

To set up LIN serial decode:

- 1 Choose **Main Menu > Analyze > Serial Decode** to display the Serial Decode Menu.



- 2 Choose whether to include the parity bits in the identifier field.
  - a If you want to mask the upper two parity bits, ensure that the box under the **Show Parity** softkey is not selected.
  - b If you want to include the parity bits in the identifier field, ensure that the box under the **Show Parity** softkey is selected.
- 3 If the decode line does not appear on the display, choose **Main Menu > Analyze > Serial Decode** again to turn it on.
- 4 If the oscilloscope is stopped, choose **Main Menu > Run/Stop** to acquire and decode data.

### NOTE

If the setup does not produce a stable trigger, the LIN signal may be slow enough that the oscilloscope is AutoTriggering. Click the Run/Stop status in the upper-right corner of the display, and change the trigger mode from **Auto** to **Normal**.

You can use the horizontal **Zoom** window for easier navigation of the decoded data.

- See Also
- ["Interpreting LIN Decode"](#) on page 340
  - ["Interpreting LIN Lister Data"](#) on page 341
  - ["Searching for LIN Data in the Lister"](#) on page 341

## Interpreting LIN Decode

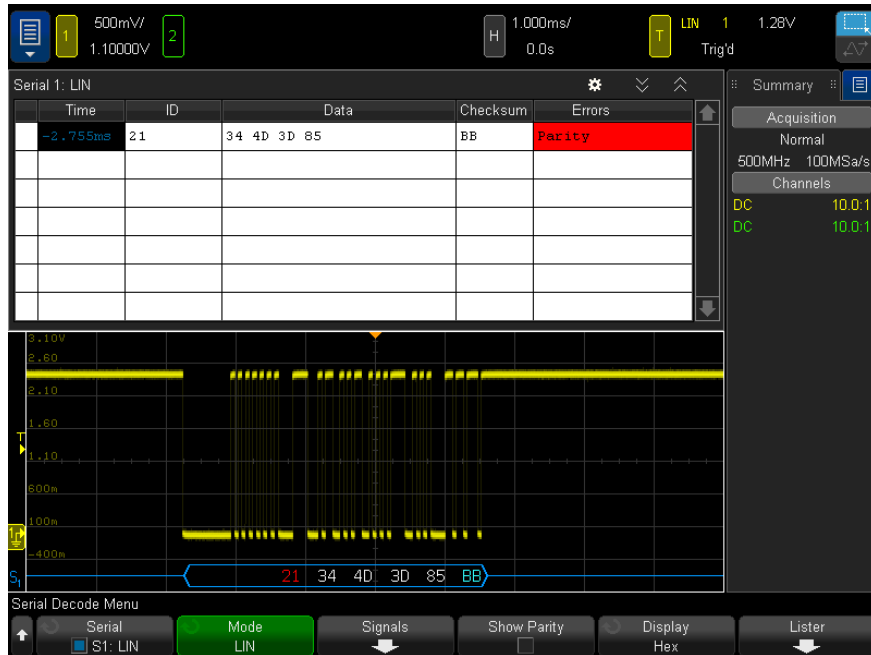

- Angled waveforms show an active bus (inside a packet/frame).
- Mid-level blue lines show an idle bus.
- The hexadecimal ID and parity bits (if enabled) appear in yellow. If a parity error is detected the hexadecimal ID and parity bits (if enabled) appear in red.
- Decoded hexadecimal data values appear in white.
- The checksum appears in blue if correct, or red if incorrect.
- Decoded text is truncated at the end of the associated frame when there is insufficient space within frame boundaries.
- Pink vertical bars indicate you need to expand the horizontal scale (and run again) to see decode.
- Red dots in the decode line indicate that there is data that is not being displayed. Scroll or expand the horizontal scale to view the information.
- Unknown bus values (undefined or error conditions) are drawn in red.
- If there is an error in the synch field, SYNC will appear in red.
- If the header exceeds the length specified in the standard, THM will appear red.
- If the total frame count exceeds the length specified in the standard, TFM will appear red (LIN 1.3 only).
- For LIN 1.3 a wakeup signal is indicated by WAKE in blue. If the wakeup signal is not followed by a valid wakeup delimiter a wakeup error is detected and displayed as WUP in red.

## Interpreting LIN Lister Data

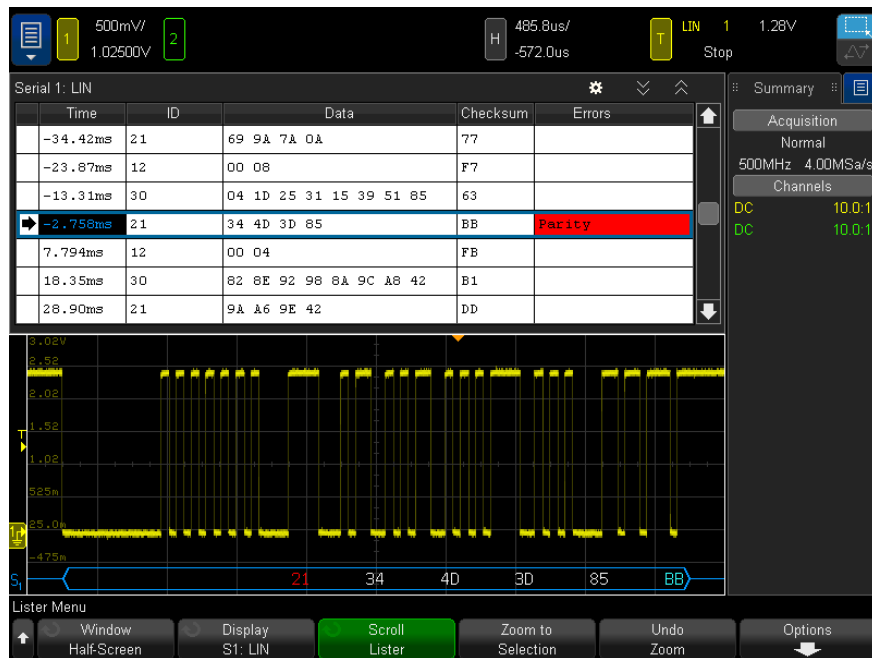

In addition to the standard Time column, the LIN Lister contains these columns:

- ID – frame ID. Can be displayed as hex digits or symbolic information (see "[Loading and Displaying LIN Symbolic Data](#)" on page 336).
- Data – data bytes. Can be displayed as hex digits or symbolic information.
- Checksum.
- Errors – highlighted in red.

Aliased data is highlighted in pink. When this happens, decrease the horizontal time/div setting and run again.

## Searching for LIN Data in the Lister

The oscilloscope's search capability lets you search for (and mark) certain types of LIN data in the Lister. You can use the sidebar **Navigate** controls to navigate through the marked rows.

- 1 With LIN selected as the serial decode mode, choose **Main Menu > Analyze > Waveform Search**.
- 2 In the Search Menu, click the **Search** softkey; then, select Serial 1 or Serial 2 on which the LIN signal is being decoded.
- 3 Click **Search for**; then, select from these options:
  - **ID** – Finds frames with the specified ID. Click the Frame ID softkey to select the ID.

- **ID & Data** – Finds frames with the specified ID and data. Click the Frame ID softkey to select the ID. Click the Bits softkey to enter the data value.
- **Errors** – Finds all errors.

For more information on searching data, see "[Searching Lister Data](#)" on page 109.

For more information on using the sidebar **Navigate** controls, see "[Navigating the Time Base](#)" on page 49.

## 22 CXPI Triggering and Serial Decode

Setup for CXPI Signals / 344

CXPI Triggering / 345

CXPI Serial Decode / 348

CXPI (Clock Extension Peripheral Interface) triggering and serial decode requires the P9240CXPA license.

## Setup for CXPI Signals

To set up the oscilloscope to capture CXPI signals:

- 1 Connect an oscilloscope channel to the signal in the device under test.  
Analog channels can be used.
- 2 Choose **Main Menu > Analyze > Serial Decode**.
- 3 Click the **Serial** softkey, select Serial 1 or Serial 2, and click the softkey again to enable decode.
- 4 Click the **Mode** softkey; then, select **CXPI**.
- 5 Click the **Bus Config** softkey to open the CXPI Bus Configuration Menu.

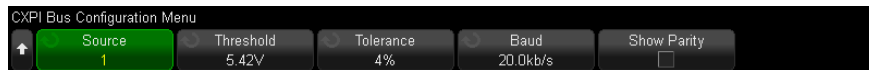

- a Click the **Source** softkey; then, select the channel for the signal.
- b Click the **Threshold** softkey; then, enter the signal threshold voltage level.  
The threshold voltage level is used in decoding, and it will become the trigger level when the trigger type is set to the selected serial decode (Serial 1 or Serial 2).
- c Click the **Tolerance** softkey; then, enter the tolerance as a percentage of the Tbit width.
- d Click the **Baud Rate** softkey; then, enter the baud rate that matches the CXPI signal from your device under test.  
The CXPI baud rate can be set from 9600 b/s to 40000 b/s in 100 b/s increments.  
You must set the baud rate to match your device under test.  
The default baud rate is 20 kb/s.
- e Select **Show Parity** to include the parity bit in the identifier field.  
When **Show Parity** is not selected, the upper bit is masked. The parity is still checked, but it is not displayed unless a parity error occurs.  
Parity errors are shown in red.
- f Click the  Back/Up softkey to return to the CXPI Serial Decode Menu.



## CXPI Triggering

To set up the oscilloscope to capture CXPI signals, see **"Setup for CXPI Signals"** on page 344.

When CXPI (Clock Extension Peripheral Interface) is selected as one of the serial bus decodes, you can trigger on CXPI signals.

CXPI frames have the following format:

### Normal frame

PID (1 byte)		Frame Info (1 byte)			Data (0-12 bytes)	CRC (1 byte)
Parity (1 bit)	Frame ID (7 bits)	DLC (4 bits)	NM (2 bits)		CT (2 bits)	
			wakeup	sleep		

### Long frame

PID (1 byte)		Frame Info (2 bytes)				Data (0-255 bytes)	CRC (2 bytes)
Parity (1 bit)	Frame ID (7 bits)	DLC (4 bits, = 0xF)	NM (2 bits)		CT (2 bits)	Extension DLC (1 byte)	
			wakeup	sleep			

- DLC = Data Length Code
- NM = Network Management
- CT = Counter

To set up a CXPI trigger condition:

- 1 Choose **Main Menu > Trigger > Trigger Menu**.
- 2 In the Trigger Menu, click the **Trigger Type** softkey; then, select the serial decode (Serial 1 or Serial 2) of the CXPI signal.



- 3 Click the **Trigger on:** softkey and select the CXPI trigger type:
  - **SOF - Start of Frame** – triggers at the start bit of any frame.
  - **EOF - End of Frame** – triggers at the end of any frame.
  - **PTYPE** – triggers on any frame that starts with the special PTYPE byte.

PTYPE frames begins with an extra PID byte with a Frame ID of 0000000b (reserved for only PTYPE frames). The PTYPE PID byte is then followed by a regular PID byte and the rest of the normal frame. The extra PTYPE byte is never included in the CRC calculation.

- **Frame ID** – triggers on a user-defined Frame ID at the end of the PID byte. The Frame ID value is user-defined, 7 bits, and has bitwise don't-cares. You can specify whether to trigger on PTYPE present or no PTYPE present.
  - **Frame ID, Info and Data** – triggers on CXPI frames at the end of the last data byte defined in the trigger. In addition to the PID value, you can specify the contents of the Frame Info byte with bitwise don't-cares. You can specify up to 12 data bytes on which to trigger with bitwise don't-cares.
  - **Frame ID, Info and Data (Long Frame)** – triggers on CXPI frames at the end of the last data byte defined in the trigger. The standard DLC field will be locked to 1111b. You can specify up to 12 bytes of data on which to trigger and specify the start byte number as an offset. The offset can be up to 123 bytes when PTYPE is present or 124 bytes when PTYPE is not present.
  - **CRC Field Error** – triggers when the calculated CRC does not match the transmitted CRC. You can optionally filter by Frame ID and PTYPE as in the Frame ID trigger.
  - **Parity Error** – triggers when the parity bit in the PID or PTYPE field is not correct.
  - **Inter-Byte Space Error** – triggers when there are more than 9 bits between consecutive bytes in a frame. You can optionally filter by Frame ID and PTYPE as in the Frame ID trigger.
  - **Inter-Frame Space Error** – triggers when there are fewer than 10 idle bits before a new frame begins.
  - **Framing Error** – triggers when the stop bit of a byte is not logical 1. You can optionally filter by Frame ID and PTYPE as in the Frame ID trigger.
  - **Data Length Error** – triggers when there are more data bytes in a frame than is indicated by the DLC or Extended DLC field. You can optionally filter by Frame ID and PTYPE as in the Frame ID trigger.
  - **Sample Error** – triggers when 10 consecutive logical 0s are detected.
  - **All Errors** – triggers on all CRC, Parity, IBS, Stop Bit, Data Length, and Sample errors.
  - **Sleep Frame** – triggers when a normal frame is transmitted matching the definition of a sleep frame in the CXPI specification.
  - **Wakeup Pulse** – triggers when a wakeup pulse is detected.
- 4 For the trigger types that let you trigger on data, click the **Bits** softkey. In the CXPI Bits Menu, you can specify ID, Frame Info, and Data values to trigger on:
- **Define** – this softkey selects what you want to specify (ID, Frame Info, or Data) and in what format (Hex, or Binary). The remaining softkeys in the menu let you enter values.
  - **PTYPE** – when specifying ID values, this softkey specifies whether you want to trigger when the special PTYPE byte is present or not present.

- **DLC** – when specifying Frame Info or Data values, this softkey specifies the data length code to trigger on. This will also affect the number of data bytes you can specify in the trigger.
  - **# of Bytes** – this softkey specifies the number of bytes of data to trigger on. It is limited by the specified DLC value but can be smaller.
  - **Start Byte #** – when triggering on long frames, the maximum number of bytes of data you can trigger on is 12, but those 12 bytes can be located at an offset within the data. This softkey specifies the offset starting byte. The starting byte can be up to 123 when PTYPE is present or up to 124 when PTYPE is not present.
- 5 When triggering on CRC Field Errors, Inter-Byte Space Errors, Framing Errors, or Data Length Errors, there is a **Filter by ID** softkey that you can enable to modify the trigger so that it occurs only for a specified ID.

**NOTE**

If the setup does not produce a stable trigger, the CXPI signals may be slow enough that the oscilloscope is AutoTriggering. Click the Run/Stop status in the upper-right corner of the display, and change the trigger mode from **Auto** to **Normal**.

---

**NOTE**

To display CXPI serial decode, see "**CXPI Serial Decode**" on page 348.

---

## CXPI Serial Decode

To set up the oscilloscope to capture CXPI signals, see ["Setup for CXPI Signals"](#) on page 344.

### NOTE

For CXPI triggering setup see ["CXPI Triggering"](#) on page 345.

To set up CXPI serial decode:

- 1 Choose **Main Menu > Analyze > Serial Decode** to display the Serial Decode Menu.



- 2 If the decode line does not appear on the display, choose **Main Menu > Analyze > Serial Decode** again to turn it on.
- 3 If the oscilloscope is stopped, choose **Main Menu > Run/Stop** to acquire and decode data.

### NOTE

If the setup does not produce a stable trigger, the CXPI signals may be slow enough that the oscilloscope is AutoTriggering. Click the Run/Stop status in the upper-right corner of the display, and change the trigger mode from **Auto** to **Normal**.

You can use the horizontal **Zoom** window for easier navigation of the acquired data.

- See Also
- ["Interpreting CXPI Decode"](#) on page 349
  - ["Interpreting CXPI Lister Data"](#) on page 350

## Interpreting CXPI Decode

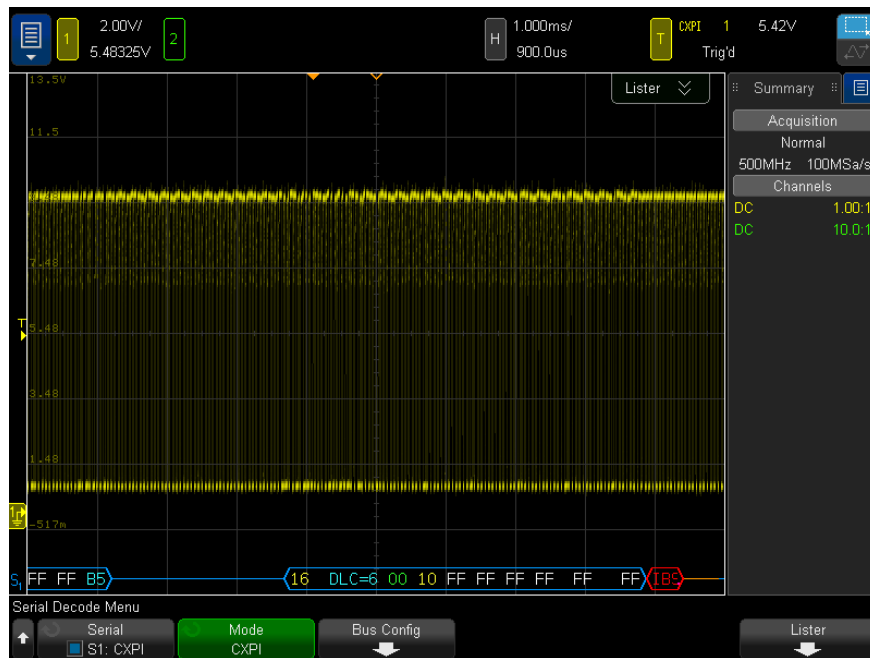

The *CXPI* decode display is color coded as follows:

- Blue angled waveforms show an active bus (inside a packet/frame).
- Blue mid-level lines show an idle bus.
- For PTYPE frames, the text "PTYPE" is shown in the decode before the Frame ID. If the parity bit in the PTYPE field is in error, the "PTYPE" text is displayed in red.
- Packet/Frame ID – yellow hex digits. The packet/frame ID can optionally show or omit the leading parity bit.
- Data Length Code (DLC) – cyan. The DLC is always a decimal value.
- Network Management (NM) – green. Binary value, two bits.
- Counter (CT) – yellow. Binary value, two bits.
- Data bytes – white text formatted as a pair of hexadecimal nibbles for each byte. These hexadecimal bytes are shown with MSB at the left..
- CRC – cyan hex digits when valid, red when error detected.
- Red angled waveforms – Unknown or error condition.
- Flagged error frames – red, with:
  - "IBS ERR" – Inter-Byte Space error. When the space between bytes in a frame is greater than 9 bits.
  - "IFS ERR" – Inter-Frame Space error. When there are fewer than 10 bits present in the idle state before a new frame starts.

- "FRAME ERR" – Framing error. When the stop bit is not a logical 1.
- "LEN ERR" – Data Length error. If the frame has more data bytes than are indicated in the DLC field.
- "SAMP ERR" – Sample error. If 10 logical 0s are detected consecutively.
- "?" – (unknown)
- Pink vertical bars – Expand horizontal scale (and run again) to see decode.
- Red Dot – More information is available. Decoded text is truncated to fit. Expand the horizontal scale to view the information.

When the bus goes into sleep conditions, special frames are drawn:

- SLEEP frame – orange. Displayed 2.5 ms after the bus goes idle-high. In the Lister, the fixed hex data values in the Data column are replaced by the text "SLEEP FRAME".
- WAKE frame – blue. When a low pulse of 250-2500  $\mu$ s is detected, it is a wakeup pulse, and a blue WAKE frame will be drawn. After that pulse will be an orange line. The decode line will turn blue/idle after the first 10 clock ticks are detected (but not before).

## Interpreting CXPI Lister Data

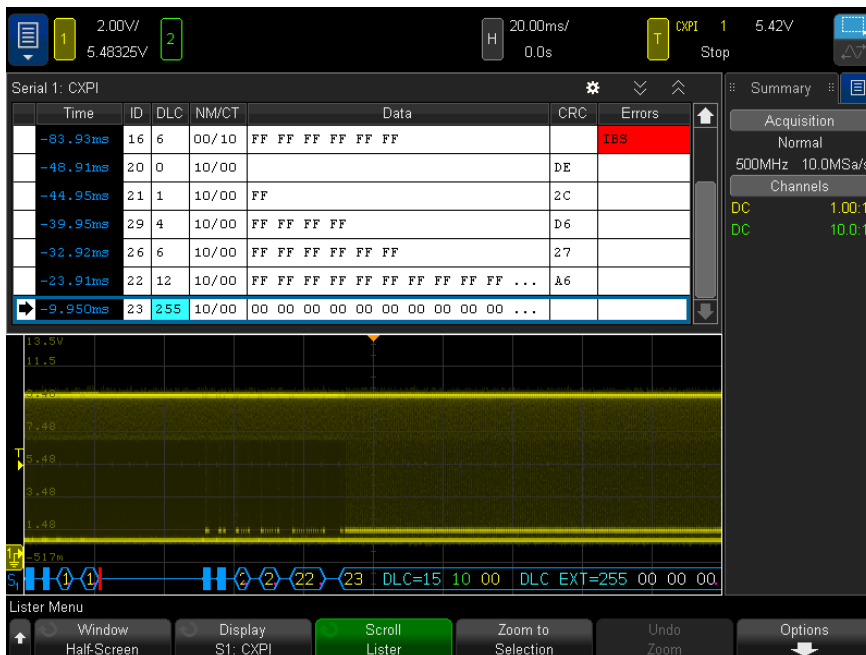

In addition to the standard Time column, the CXPI Lister contains these columns:

- ID – value in Hex.
- DLC – (Data Length Code) values in Decimal.

- NM/CT – (Network Management/Counter) values in Binary.
- Data – values in Hex.  
For sleep frames, data values are replaced by the text "SLEEP FRAME".
- CRC – value in Hex.
- Errors – string value that displays the type of error detected:
  - CRC – CRC Error.
  - Parity Error.
  - IBS – IBS Error.
  - Fr – Frame Error.
  - LEN – LENGTH Error.
  - SAMP – SAMPLE Error.





# 23 I2C Triggering and Serial Decode

Setup for I2C Signals / 354

I2C Triggering / 355

I2C Serial Decode / 358

I2C triggering and serial decode requires the EMBD license that you can get by purchasing the P9240EMBA upgrade.

## Setup for I2C Signals

I<sup>2</sup>C (Inter-IC bus) signals setup consists of connecting the oscilloscope to the serial data (SDA) line and the serial clock (SCL) line and then specifying the input signal threshold voltage levels.

To set up the oscilloscope to capture I<sup>2</sup>C signals, use the **Signals** softkey which appears in the Serial Decode Menu:

- 1 Choose **Main Menu > Analyze > Serial Decode**.
- 2 Click the **Serial** softkey, select Serial 1 or Serial 2, and click the softkey again to enable decode.
- 3 Click the **Mode** softkey; then, select **I2C**.
- 4 Click the **Signals** softkey to open the I<sup>2</sup>C Signals Menu.



- 5 For both the SCL (serial clock) and SDA (serial data) signals:
  - a Connect an oscilloscope channel to the signal in the device under test.
  - b Click the **SCL** or **SDA** softkey; then, select the channel for the signal.
  - c Click the corresponding **Threshold** softkey; then, enter the signal threshold voltage level.

The threshold voltage level is used in decoding, and it will become the trigger level when the trigger type is set to the selected serial decode slot.

Data must be stable during the whole high clock cycle or it will be interpreted as a start or stop condition (data transitioning while the clock is high).

The SCL and SDA labels for the source channels are automatically set.

## I2C Triggering

To set up the oscilloscope to capture I2C signals, see "[Setup for I2C Signals](#)" on page 354.

After the oscilloscope has been set up to capture I2C signals, you can trigger on a stop/start condition, a restart, a missing acknowledge, an EEPROM data read, or on a read/write frame with a specific device address and data value.

- 1 Choose **Main Menu > Trigger > Trigger Menu**.
- 2 In the Trigger Menu, click the **Trigger Type** softkey; then, select the Serial 1 or Serial 2 on which the I<sup>2</sup>C signals are being decoded.



- 3 Click the **Trigger on:** softkey; then, select the trigger condition:
  - **Start Condition**— The oscilloscope triggers when SDA data transitions from high to low while the SCL clock is high. For triggering purposes (including frame triggers), a restart is treated as a start condition.
  - **Stop Condition**— The oscilloscope triggers when data (SDA) transitions from low to high while the clock (SCL) is high.

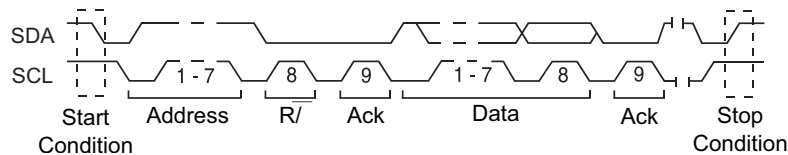

- **Missing Acknowledge**— The oscilloscope triggers when SDA data is high during any Ack SCL clock bit.
- **Address with no Ack**— The oscilloscope triggers when the acknowledge of the selected address field is false. The R/W bit is ignored.
- **Restart**— The oscilloscope triggers when another start condition occurs before a stop condition.
- **EEPROM Data Read**— The trigger looks for EEPROM control byte value 1010xxx on the SDA line, followed by a Read bit and an Ack bit. It then looks for the data value and qualifier set by the **Data** softkey and the **Data is** softkey. When this event occurs, the oscilloscope will trigger on the clock edge for the Ack bit after the data byte. This data byte does not need to occur directly after the control byte.

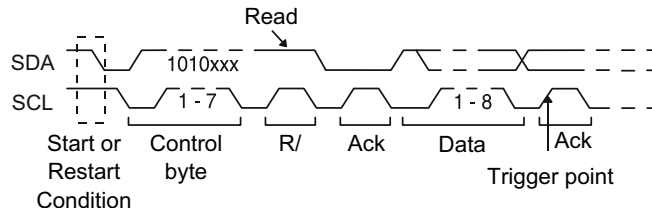

- **Frame (Start: Addr7: Read: Ack: Data) or Frame (Start: Addr7: Write: Ack: Data)**– The oscilloscope triggers on a read or write frame in 7-bit addressing mode on the 17th clock edge if all bits in the pattern match. For triggering purposes, a restart is treated as a start condition.

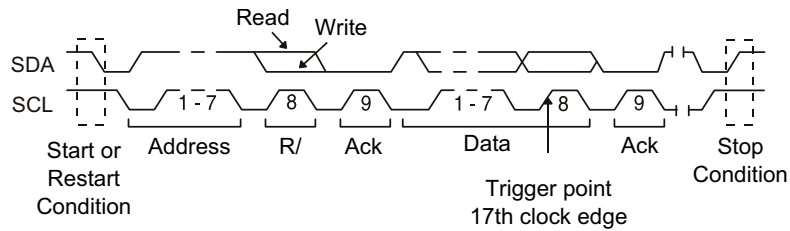

- **Frame (Start: Addr7: Read: Ack: Data: Ack: Data2) or Frame (Start: Addr7: Write: Ack: Data: Ack: Data2)**– The oscilloscope triggers on a read or write frame in 7-bit addressing mode on the 26th clock edge if all bits in the pattern match. For triggering purposes, a restart is treated as a start condition.

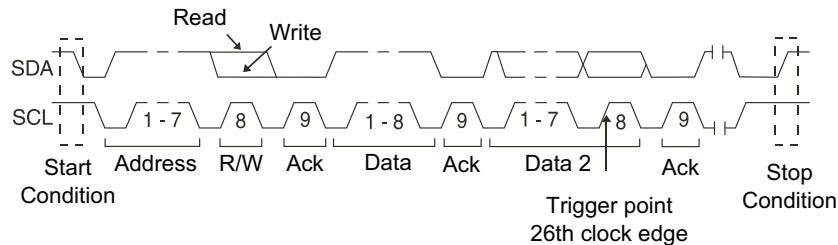

- **10-bit Write** – The oscilloscope triggers on a 10-bit write frame on the 26th clock edge if all bits in the pattern match. The frame is in the format:  
 Frame (Start: Address byte 1: Write: Address byte 2: Ack: Data)  
 For triggering purposes, a restart is treated as a start condition.

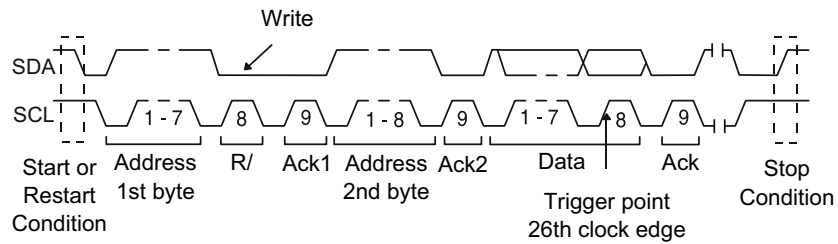

- 4 If you have set the oscilloscope to trigger on an EEPROM Data Read condition:

Click the **Data is** softkey to set the oscilloscope to trigger when data is = (equal to),  $\neq$  (not equal to), < (less than), or > (greater than) the data value set in the **Data** softkey.

The oscilloscope will trigger on the clock edge for the Ack bit after the trigger event is found. This data byte does not need to occur directly after the control byte. The oscilloscope will trigger on any data byte that meets the criteria defined by the **Data is** and **Data** softkeys during a current address read or a random read or a sequential read cycle.

- 5 If you have set the oscilloscope to trigger on a 7-bit address read or write frame condition or a 10-bit write frame condition:

- a Click the **Address** softkey and select the 7-bit or 10-bit device address.

You can select from an address range of 0x00 to 0x7F (7-bit) or 0x3FF (10-bit) hexadecimal. When triggering on a read/write frame, the oscilloscope will trigger after the start, address, read/write, acknowledge, and data events occur.

If don't care is selected (0xFF or 0xFFFF) for the address, the address will be ignored. The trigger will always occur on the 17th clock for 7-bit addressing or 26th clock for 10-bit addressing.

- b Click the **Data** value softkey and select the 8-bit data pattern on which to trigger.

You can select a data value in the range of 0x00 to 0xFF (hexadecimal). The oscilloscope will trigger after the start, address, read/write, acknowledge, and data events occur.

If don't care (0xFF) is selected for data, the data will be ignored. The trigger will always occur on the 17th clock for 7-bit addressing or 26th clock for 10-bit addressing.

- c If you have selected a three-byte trigger, click the **Data2** value softkey and select the 8-bit data pattern on which to trigger.

#### NOTE

To display I2C serial decode, see "**I2C Serial Decode**" on page 358.

## I2C Serial Decode

To set up the oscilloscope to capture I2C signals, see ["Setup for I2C Signals"](#) on page 354.

### NOTE

For I2C triggering setup see ["I2C Triggering"](#) on page 355.

To set up I2C serial decode:

- 1 Choose **Main Menu > Analyze > Serial Decode** to display the Serial Decode Menu.



- 2 Choose 7-bit or 8-bit address size. Use 8-bit address size to include the R/W bit as part of the address value, or choose 7-bit address size to exclude the R/W bit from the address value.
- 3 If the decode line does not appear on the display, choose **Main Menu > Analyze > Serial Decode** again to turn it on.
- 4 If the oscilloscope is stopped, choose **Main Menu > Run/Stop** to acquire and decode data.

### NOTE

If the setup does not produce a stable trigger, the I2C signals may be slow enough that the oscilloscope is AutoTriggering. Click the Run/Stop status in the upper-right corner of the display, and change the trigger mode from **Auto** to **Normal**.

You can use the horizontal **Zoom** window for easier navigation of the acquired data.

- See Also
- ["Interpreting I2C Decode"](#) on page 359
  - ["Interpreting I2C Lister Data"](#) on page 360
  - ["Searching for I2C Data in the Lister"](#) on page 360

## Interpreting I2C Decode

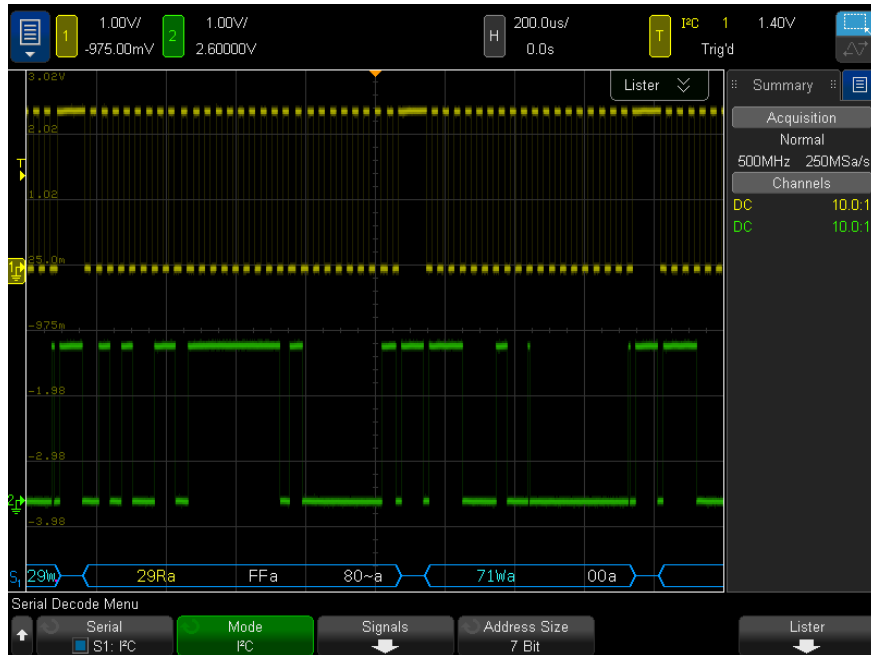

- Angled waveforms show an active bus (inside a packet/frame).
- Mid-level blue lines show an idle bus.
- In the decoded hexadecimal data:
  - Address values appear at the start of a frame.
  - Write addresses appear in light-blue along with the "W" character.
  - Read addresses appear in yellow along with the "R" character.
  - Restart addresses appear in green along with the "S" character.
  - Data values appear in white.
  - "a" indicates Ack (low), "~a" indicates No Ack (high).
  - Decoded text is truncated at the end of the associated frame when there is insufficient space within frame boundaries.
- Pink vertical bars indicate you need to expand the horizontal scale (and run again) to see decode.
- Red dots in the decode line indicate that more data can be displayed. Scroll or expand the horizontal scale to view the data.
- Aliased bus values (undersampled or indeterminate) are drawn in pink.
- Unknown bus values (undefined or error conditions) are drawn in red.

## Interpreting I2C Lister Data

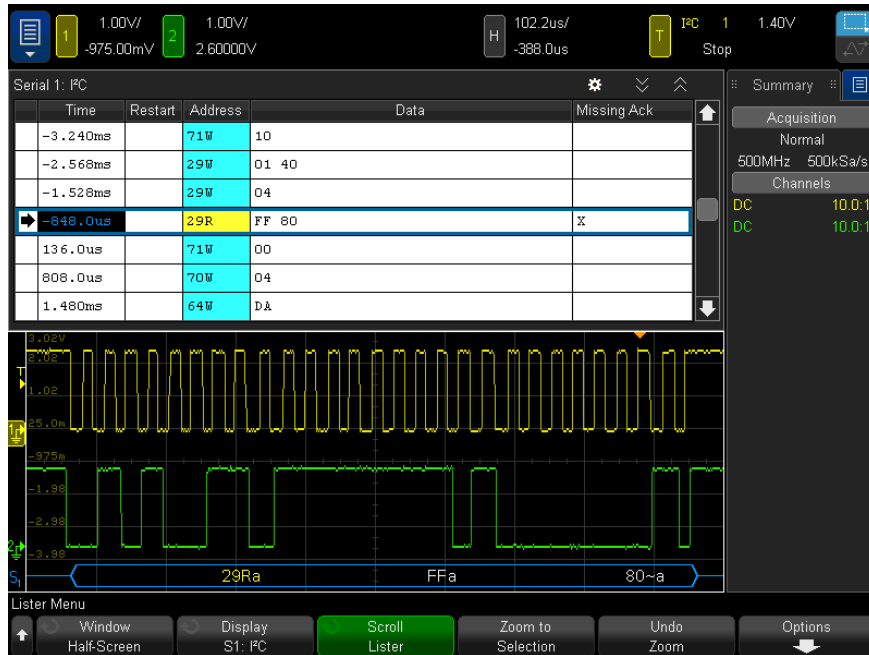

In addition to the standard Time column, the I2C Lister contains these columns:

- Restart – indicated with an "X".
- Address – colored blue for writes, yellow for reads.
- Data – data bytes.
- Missing Ack – indicated by an "X", highlighted in red if an error.

Aliased data is highlighted in pink. When this happens, decrease the horizontal time/div setting and run again.

## Searching for I2C Data in the Lister

The oscilloscope's search capability lets you search for (and mark) certain types of I2C data in the Lister. You can use the sidebar **Navigate** controls to navigate through the marked rows.

- 1 With I2C selected as the serial decode mode, choose **Main Menu > Analyze > Waveform Search**.
- 2 In the Search Menu, click the **Search** softkey; then, select Serial 1 or Serial 2 on which the I2C signal is being decoded.
- 3 Click **Search for**; then, select from these options:
  - **Missing Acknowledge** – finds SDA data is high during any Ack SCL clock bit.



- **Address with no Ack** – finds when the acknowledge of the selected address field is false. The R/W bit is ignored.
- **Restart** – finds when another start condition occurs before a stop condition.
- **EEPROM Data Read** – finds EEPROM control byte value 1010xxx on the SDA line, followed by a Read bit and an Ack bit. It then looks for the data value and qualifier set by the Data is softkey and the Data softkeys.
- **Frame(Start:Address7:Read:Ack:Data)** – finds a read frame on the 17th clock edge if all bits in the pattern match.
- **Frame(Start:Address7:Write:Ack:Data)** – finds a write frame on the 17th clock edge if all bits in the pattern match.
- **Frame(Start:Address7:Read:Ack:Data:Ack:Data2)** – finds a read frame on the 26th clock edge if all bits in the pattern match.
- **Frame(Start:Address7:Write:Ack:Data:Ack:Data2)** – finds a write frame on the 26th clock edge if all bits in the pattern match.

For more information on searching data, see "[Searching Lister Data](#)" on page 109.

For more information on using the sidebar **Navigate** controls, see "[Navigating the Time Base](#)" on page 49.



## 24 Manchester/NRZ Triggering and Serial Decode

Setup for Manchester Signals / 364

Manchester Triggering / 367

Manchester Serial Decode / 369

Setup for NRZ Signals / 372

NRZ Triggering / 375

NRZ Serial Decode / 377

Manchester/NRZ triggering and serial decode requires the NRZ license that you can get by purchasing the P9240NRZA upgrade.

The Manchester/NRZ triggering and decode solutions support generic Manchester- or NRZ-encoded serial buses.

## Setup for Manchester Signals

Manchester signal setup consists of first connecting the oscilloscope to a Manchester-encoded serial bus signal, then specifying the signal, bus configuration, and other settings.

To set up the oscilloscope to capture Manchester signals:

- 1 Press **[Serial]**.
- 2 Press the **Serial** softkey and choose the serial decode (Serial 1 or Serial 2) to use; then, press the softkey again to enable decode.
- 3 Press the **Mode** softkey; then, select the **Manchester** decode mode.
- 4 Press the **Signals** softkey to open the Manchester Signals Menu.



In the Manchester Signals Menu:

- a Press the **Source** softkey to select the channel connected to the Manchester signal line.

The label for the Manchester source channel is automatically set.

- b Press the **Threshold** softkey; then, enter the trigger threshold voltage level.

The threshold voltage level is used in decoding and will become the trigger level when the trigger type is set to the Manchester serial decode.

- c Press the **Baud** softkey; then, enter the baud rate of the Manchester signal from your device under test.

The baud rate can be set from 2 kb/s to 5 Mb/s in 100 b/s increments.

You must set the baud rate to match your device under test.

The default baud rate is 125 kb/s.

- d Press the **Tolerance** softkey to specify the tolerance for the Manchester signal. Valid values range from 5% to 30% in terms of percentage of the bit period.

- e Press the  Back/Up key to return to the Serial Decode Menu.

- 5 Press the **Bus Config** softkey to open the Manchester Bus Configuration Menu.



In the Manchester Bus Configuration Menu:

- a Press the **Display Format** softkey and select the display format:
  - **Word** – lets you break the frame into sync, header, data, and trailer fields.
 

In Word format, you can select between hexadecimal, unsigned decimal, and ASCII decode bases. The base setting is used for both the Lister and the decode line and applies to the data field only. The header and trailer fields are always displayed in hex.
  - **Bit** – displays the entire content of the frame as a string of bits.
 

In Bit format, the entire frame is always displayed in binary.
- 6 If the **Word** display format is selected:
  - a Press the **Sync Size** softkey and enter the sync field size, from 0 to 255 bits.
  - b Press the **Header Size** softkey and enter the header size, from 0 to 32 bits.
  - c Press the **# of Words** softkey and enter the number of words in the data field, from 1 to 255.
 

When the **Trailer Size** is set to 0, the <auto> option becomes available. In <auto> mode, any number of words can be supported.
  - d Press the **Data Word Size** softkey and enter the data word size, from 2 to 32 bits.
  - e Press the **Trailer Size** softkey and enter the trailer size, from 0 to 32 bits.
- 7 If the **Bits** display format is selected:
  - a Press the **Sync Size** softkey and enter the sync field size, from 0 to 255 bits.
- 8 Press the  Back/Up key to return to the Serial Decode Menu.
- 9 Press the **Settings** softkey to open the Manchester Settings Menu.



In the Manchester Settings Menu:

- a Press the **Start Edge #** softkey and enter the starting edge of the Manchester signal, from 1 to 256.
- b Press the **Polarity** softkey and select the Manchester signal's logic type:
  - Rising – specifies that a rising edge is used to encode a bit value of logic 1 (and a falling edge encodes a bit value of logic 0).
  - Falling – specifies that a falling edge is used to encode a bit value of logic 1 (and a rising edge encodes a bit value of logic 0).
- c Press the **Bit Order** softkey and select the bit order, either most significant bit first (*MSB*) or least significant bit first (*LSB*).

The selected order is used when displaying data in the serial decode waveform and in the Lister.

This softkey is available when the **Word** display format is selected in the Manchester Bus Configuration Menu.

- d** Press the **Idle Bits** softkey and enter the minimum idle time/inter-frame gap time of the Manchester bus in terms of the bit width.

Framing is determined by idle time.

- e** Use the **Decode Base** softkey to select between hexadecimal, unsigned decimal, or ASCII display of the decoded data.

The decode base setting is used for the display of the data field in both the decode line and in the Lister.

When the **Bit** display format is selected in the Manchester Bus Configuration Menu, this softkey is unavailable and the decode base is forced to Binary.

- f** Press the  Back/Up key to return to the Serial Decode Menu.

## Manchester Triggering

To set up the oscilloscope to capture a Manchester signal, see "[Setup for Manchester Signals](#)" on page 364.

To set up a Manchester trigger:

- 1 Press **[Trigger]**.
- 2 In the Trigger Menu, press the **Trigger Type** softkey; then, select the Manchester decode (Serial 1 or Serial 2).



- 3 Press the **Trigger** softkey; then, select the trigger condition:
  - **SOF - Start of Frame** – triggers after the starting edge, between the starting edge and the sync field.
  - **Value** – triggers on a value you specify, up to 128 bits, after the sync field (starting with header bits).

Note that the trigger value is always for bits as they arrive (that is, MSB first).

When the decode bit order (specified in the serial decode settings menu) is MSB first, the decoded value bit order matches the trigger value bit order.

When the serial decode bit order is LSB first, the decoded value bit order is opposite of the trigger value bit order.

When Value is selected:

- i Press the **#Bits** softkey and set the number of bits in the serial data value, from 4 bits to 128 bits.

The serial data value is displayed in the Value string in the waveform area.

- ii Press the **Value** softkey and use the keypad dialog box to enter the data value.

Note that the trigger value is always for bits as they arrive (that is, MSB first).

When the decode bit order (specified in the serial decode settings menu) is MSB first, the decoded value bit order matches the trigger value bit order.

When the serial decode bit order is LSB first, the decoded value bit order is opposite of the trigger value bit order.

- **Manchester Error** – triggers if a Manchester encoding error is detected.

You can use the **Zoom** mode for easier navigation of the decoded data.

**NOTE**

For Manchester decode information see "[Manchester Serial Decode](#)" on page 369.

---



## Manchester Serial Decode

To set up the oscilloscope to capture Manchester signals, see "[Setup for Manchester Signals](#)" on page 364.

### NOTE

For Manchester triggering setup see "[Manchester Triggering](#)" on page 367.

To set up Manchester serial decode:

- 1 Press [**Serial**] to display the Serial Decode Menu.



- 2 If the decode line does not appear on the display, press the [**Serial**] key to turn it on.
- 3 If the oscilloscope is stopped, press the [**Run/Stop**] key to acquire and decode data.

### NOTE

If the setup does not produce a stable trigger, the Manchester signal may be slow enough that the oscilloscope is AutoTriggering. Press the [**Mode/Coupling**] key, then press the **Mode** softkey to set the trigger mode from **Auto** to **Normal**.

You can use the horizontal **Zoom** window for easier navigation of the decoded data.

- See Also
- "[Interpreting Manchester Decode](#)" on page 369
  - "[Interpreting Manchester Lister Data](#)" on page 371

## Interpreting Manchester Decode

To display serial decode information, you must press [**Run**] or [**Single**] after switching on serial decode.

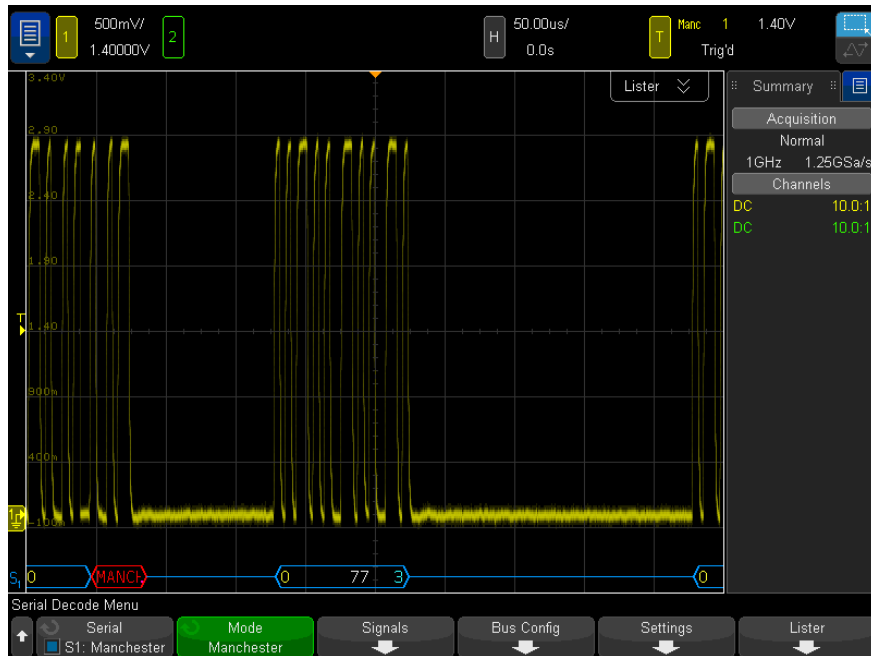

The Manchester decode display is color coded as follows:

- In Word format:
  - Header (yellow)
  - Data (white)
  - Trailer (blue)
- In Bit format:
  - Value (white)

The decode display shows a blue idle line until the specified starting edge # is reached, at which point the start of frame angle bracket is drawn in blue.

In Word format, no value is associated with the sync field. The first value displayed on the decoded bus is associated with the header field if you select a header size > 0. Otherwise, the first value displayed is associated with the data field. The end of frame angle bracket is drawn in blue at the end of the trailer field, or data field if the trailer size is 0, followed by a blue idle line.

In Bit format, the frame is not divided into fields. All bits in the frame are displayed as soon as the starting edge occurs. Each bit is displayed on the decoded bus, time-aligned with the corresponding Manchester signal.

The only type of error that will be reported in the Manchester decode is Manchester Error. When this occurs, a red error frame is drawn with the text "MANCH" in red inside the error frame. Any previously valid frame before the error is terminated with a blue closing > angle bracket. Because all data is assumed

invalid following a Manchester Error, the red error frame is drawn until a valid idle signal is detected. In the sync field, any bit value errors are ignored. Manchester errors are reported anywhere in the frame.

## Interpreting Manchester Lister Data

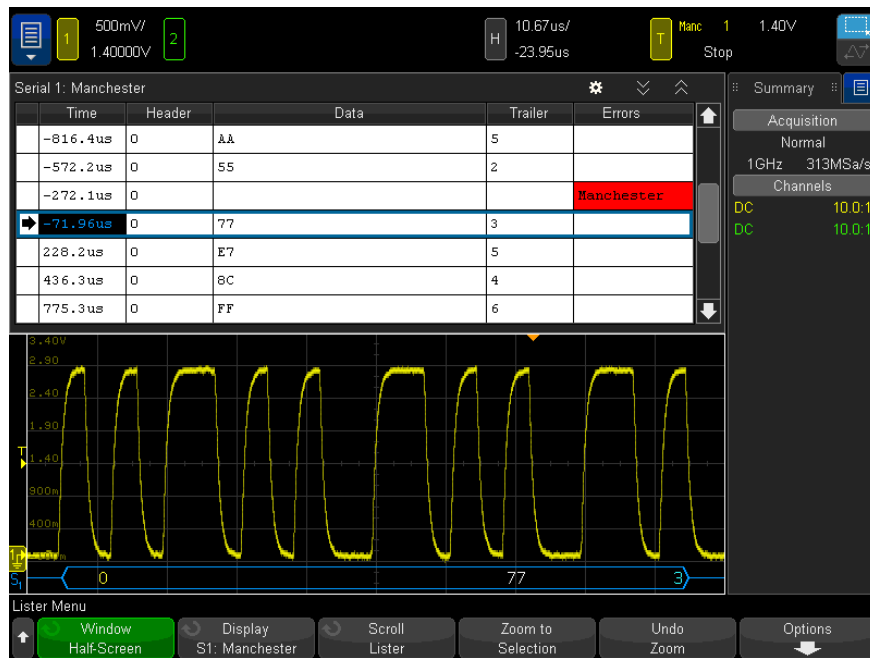

In addition to the standard Time column, the Manchester Lister contains these columns:

- In Word format:
  - Header (hex)
  - Data (hex, unsigned decimal, or ASCII)
  - Trailer (hex)
  - Errors
- In Bit format:
  - Value (binary)
  - Errors

Aliased data is highlighted in pink. When this happens, decrease the horizontal time/div setting and run again.

## Setup for NRZ Signals

NRZ signal setup consists of first connecting the oscilloscope to a NRZ-encoded serial bus signal, then specifying the signal, bus configuration, and other settings.

To set up the oscilloscope to capture NRZ signals:

- 1 Press [**Serial**].
- 2 Press the **Serial** softkey and choose the serial decode (Serial 1 or Serial 2) to use; then, press the softkey again to enable decode.
- 3 Press the **Mode** softkey; then, select the **NRZ** decode mode.
- 4 Press the **Signals** softkey to open the NRZ Signals Menu.



In the NRZ Signals Menu:

- a Press the **Source** softkey to select the channel connected to the NRZ signal line.  
The label for the NRZ source channel is automatically set.
  - b Press the **Threshold** softkey; then, enter the trigger threshold voltage level.  
The threshold voltage level is used in decoding and will become the trigger level when the trigger type is set to the NRZ serial decode.
  - c Press the **Baud** softkey; then, enter the baud rate of the NRZ signal from your device under test.  
The baud rate can be set from 5 kb/s to 5 Mb/s in 100 b/s increments.  
You must set the baud rate to match your device under test.  
The default baud rate is 125 kb/s.
  - d Press the  Back/Up key to return to the Serial Decode Menu.
- 5 Press the **Bus Config** softkey to open the NRZ Bus Configuration Menu.



In the NRZ Bus Configuration Menu:

- a Press the **Display Format** softkey and select the display format:
  - **Word** – lets you break the frame into header, data, and trailer fields.

In Word format, you can select between hexadecimal, unsigned decimal, and ASCII decode bases. The base setting is used for both the Lister and the decode line and applies to the data field only. The header and trailer fields are always displayed in hex.

- **Bit** – displays the entire content of the frame as a string of bits.

In Bit format, the entire frame is always displayed in binary.

- 6 If the **Word** display format is selected:
  - a Press the **# Start Bits** softkey and enter the number of starting bits, from 0 to 255 bits.
  - b Press the **Header Size** softkey and enter the header size, from 0 to 32 bits.
  - c Press the **# of Words** softkey and enter the number of words in the data field, from 1 to 255.
  - d Press the **Data Word Size** softkey and enter the data word size, from 2 to 32 bits.
  - e Press the **Trailer Size** softkey and enter the trailer size, from 0 to 32 bits.
- 7 If the **Bits** display format is selected:
  - a Press the **# Start Bits** softkey and enter the number of starting bits, from 0 to 255 bits.
  - b Press the **Frame Size** softkey and enter the total frame size of the NRZ signal, from 2 to 255 bits.
 

This would be equivalent to the sum of the number of bits in the header, data, and trailer fields in Word display format.
- 8 Press the  Back/Up key to return to the Serial Decode Menu.
- 9 Press the **Settings** softkey to open the NRZ Settings Menu.



In the NRZ Settings Menu:

- a Press the **Polarity** softkey and select the NRZ signal's logic type:
  - High – specifies that a positive voltage is used to encode a bit value of logic 1 (and a negative voltage encodes a bit value of logic 0).
  - Low – specifies that a negative voltage is used to encode a bit value of logic 1 (and a positive voltage encodes a bit value of logic 0).
- b Press the **Bit Order** softkey and select the bit order, either most significant bit first (*MSB*) or least significant bit first (*LSB*).

The selected order is used when displaying data in the serial decode waveform and in the Lister.

- c Press the **Idle State** softkey and choose the idle state of the NRZ bus, either Low or High.
- d Press the **Idle Bits** softkey and enter the minimum idle time/inter-frame gap time of the NRZ bus in terms of the bit width.

Framing is determined by idle time.

- e Use the **Decode Base** softkey to select between hexadecimal, unsigned decimal, or ASCII display of the decoded data.

The decode base setting is used for the display of the data field in both the decode line and in the Lister.

- f Press the  Back/Up key to return to the Serial Decode Menu.

## NRZ Triggering

To set up the oscilloscope to capture a NRZ signal, see "[Setup for NRZ Signals](#)" on page 372.

To set up a NRZ signal:

- 1 Press **[Trigger]**.
- 2 In the Trigger Menu, press the **Trigger Type** softkey; then, select the NRZ decode (Serial 1 or Serial 2).



- 3 Press the **Trigger** softkey; then, select the trigger condition:
  - **SOF - Start of Frame** – triggers after the starting edge, at the start of a NRZ frame.
  - **Value** – triggers on a value you specify, up to 128 bits, after the specified number of starting bits.

Note that the trigger value is always for bits as they arrive (that is, MSB first).

When the decode bit order (specified in the serial decode settings menu) is MSB first, the decoded value bit order matches the trigger value bit order.

When the serial decode bit order is LSB first, the decoded value bit order is opposite of the trigger value bit order.

When Value is selected:

- i Press the **#Bits** softkey and set the number of bits in the serial data value, from 4 bits to 128 bits.

The serial data value is displayed in the Value string in the waveform area.

- ii Press the **Value** softkey and use the keypad dialog box to enter the data value.

Note that the trigger value is always for bits as they arrive (that is, MSB first).

When the decode bit order (specified in the serial decode settings menu) is MSB first, the decoded value bit order matches the trigger value bit order.

When the serial decode bit order is LSB first, the decoded value bit order is opposite of the trigger value bit order.

You can use the **Zoom** mode for easier navigation of the decoded data.

**NOTE**

To display NRZ serial decode, see "[NRZ Serial Decode](#)" on page 377.

---



## NRZ Serial Decode

To set up the oscilloscope to capture NRZ signals, see "[Setup for NRZ Signals](#)" on page 372.

### NOTE

For NRZ triggering set up see "[NRZ Triggering](#)" on page 375.

To set up NRZ serial decode:

- 1 Press [**Serial**] to display the Serial Decode Menu.



- 2 If the decode line does not appear on the display, press the [**Serial**] key to turn it on.
- 3 If the oscilloscope is stopped, press the [**Run/Stop**] key to acquire and decode data.

### NOTE

If the setup does not produce a stable trigger, the NRZ signal may be slow enough that the oscilloscope is AutoTriggering. Press the [**Mode/Coupling**] key, then press the **Mode** softkey to set the trigger mode from **Auto** to **Normal**.

You can use the horizontal **Zoom** window for easier navigation of the decoded data.

- See Also
- "[Interpreting NRZ Decode](#)" on page 378
  - "[Interpreting NRZ Lister Data](#)" on page 379

## Interpreting NRZ Decode

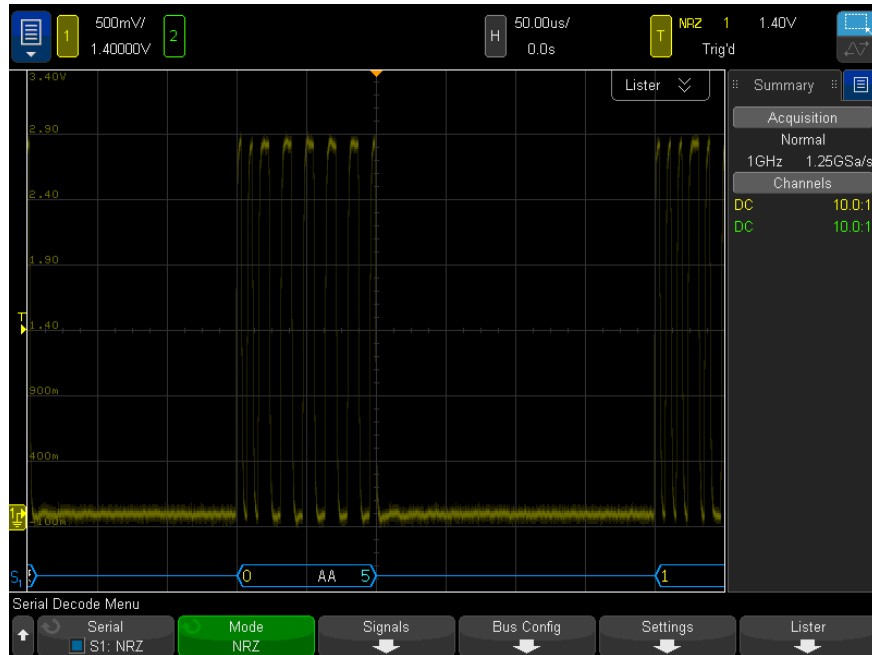

The NRZ decode display is color coded as follows:

- Word format
  - Header (yellow)
  - Data (white)
  - Trailer (blue)
- Bit format
  - Value (white)

The decode display shows a blue idle line until the start of frame, at which point, the start of frame angle bracket is drawn in blue.

In Word format, the first value displayed on the decoded bus is associated with the header field if you select a header size > 0. Otherwise, the first value displayed is associated with the data field. The end of frame angle bracket is drawn in blue at the end of the trailer field, or data field if the trailer size is 0, followed by a blue idle line.

In Bit format, the frame is not divided into fields. All bits in the frame are displayed as soon as the start of frame occurs. Each bit is displayed on the decoded bus, time-aligned with the corresponding NRZ signal.

## Interpreting NRZ Lister Data

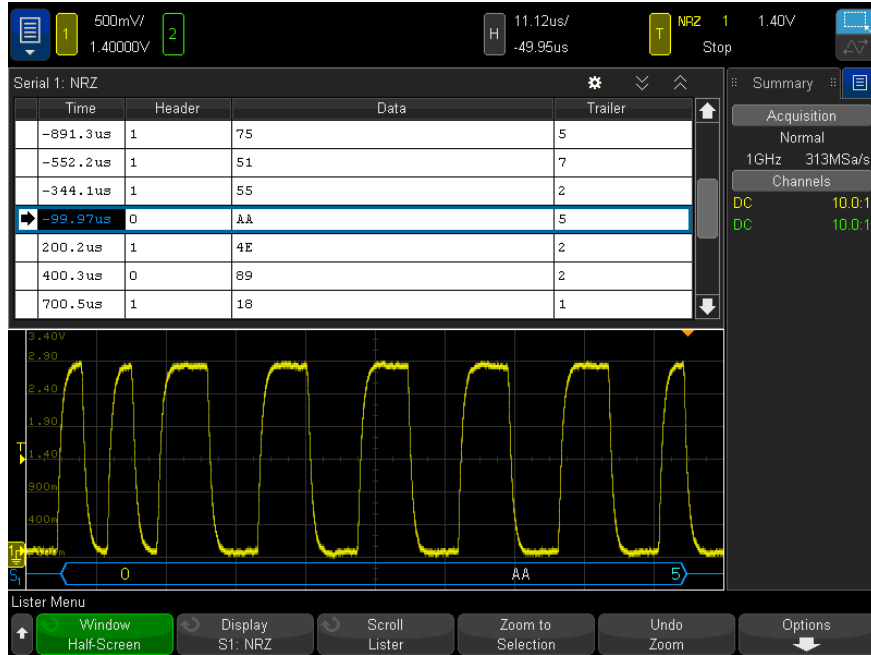

In addition to the standard Time column, the NRZ Lister contains these columns:

- In Word format:
  - Header (hex)
  - Data (hex, unsigned decimal, or ASCII)
  - Trailer (hex)
- In Bit format:
  - Value (binary)

Aliased data is highlighted in pink. When this happens, decrease the horizontal time/div setting and run again.



# 25 MIL-STD-1553/ARINC 429 Triggering and Serial Decode

Setup for MIL-STD-1553 Signals / 382

MIL-STD-1553 Triggering / 383

MIL-STD-1553 Serial Decode / 384

Setup for ARINC 429 Signals / 388

ARINC 429 Triggering / 390

ARINC 429 Serial Decode / 392

MIL-STD-1553/ARINC 429 triggering and serial decode requires the AERO license that you can get by purchasing the P9240AROA upgrade.

The MIL-STD-1553 triggering and decode solution supports bi-phase MIL-STD-1553 signaling by using dual threshold triggering. The solution supports the standard 1553 Manchester II encoding, data rate of 1 Mb/s, and word length of 20 bits.

## Setup for MIL-STD-1553 Signals

MIL-STD-1553 signal setup consists of first connecting the oscilloscope to a serial MIL-STD-1553 signal using a differential active probe (the Keysight N2791A is recommended), specifying the signal source, and specifying the high and low trigger threshold voltage levels.

To set up the oscilloscope to capture MIL-STD-1553 signals:

- 1 Choose **Main Menu > Analyze > Serial Decode**.
- 2 Click the **Serial** softkey, select Serial 1 or Serial 2, and click the softkey again to enable decode.
- 3 Click the **Mode** softkey; then, select **MIL-STD-1553**.
- 4 Click the **Signals** softkey to open the MIL-STD-1553 Signals Menu.



- 5 Click the **Source** softkey to select the channel connected to the MIL-STD-1553 signal line.

The label for the MIL-STD-1553 source channel is automatically set.

- 6 Click the  Back/Up softkey to return to the Serial Decode Menu.
- 7 Click the **Auto Setup** softkey which performs these actions:
  - Sets the probe attenuation factor of the input Source channel to 10:1.
  - Sets upper and lower thresholds to a voltage value equal to  $\pm 1/3$  division based on the current V/div setting.
  - Turns off trigger noise reject.
  - Turns on Serial Decode.
  - Sets the trigger type to MIL-1553.
- 8 If the upper and lower thresholds are not set correctly by **Auto Setup**, Click the **Signals** softkey to return to the MIL-STD-1553 Signals Menu. Then:
  - Click the **High Threshold** softkey; then, enter the high trigger threshold voltage level.
  - Click the **Low Threshold** softkey; then, enter the low trigger threshold voltage level.

The threshold voltage levels are used in decoding and will become the trigger levels when the trigger type is set to the selected serial decode slot.

## MIL-STD-1553 Triggering

To set up the oscilloscope to capture a MIL-STD-1553 signal, see "[Setup for MIL-STD-1553 Signals](#)" on page 382.

To set up a MIL-STD-1553 trigger:

- 1 Choose **Main Menu > Trigger > Trigger Menu**.
- 2 In the Trigger Menu, click the **Trigger Type** softkey; then, select Serial 1 or Serial 2 on which the MIL-STD-1553 signal is being decoded.



- 3 Click the **Trigger** softkey; then, select the trigger condition:
  - **Data Word Start** – triggers on the start of a Data word (at the end of a valid Data Sync pulse).
  - **Data Word Stop** – triggers on the end of a Data word.
  - **Command/Status Word Start** – triggers on the start of Command/Status word (at the end of a valid C/S Sync pulse).
  - **Command/Status Word Stop** – triggers on the end of a Command/Status word.
  - **Remote Terminal Address** – triggers if the RTA of the Command/Status word matches the specified value.

When this option is selected, the **RTA** softkey becomes available and lets you select the hex Remote Terminal Address value to trigger on. If you select 0xXX (don't cares), the oscilloscope will trigger on any RTA.

- **Remote Terminal Address + 11 Bits** – triggers if the RTA and the remaining 11 bits match the specified criteria.

When this option is selected, these softkeys become available:

- The **RTA** softkey lets you select the hex Remote Terminal Address value.
- The **Bit Time** softkey lets you select the bit time position.
- The **0 1 X** softkey lets you set the bit time position value as a 1, 0, or X (don't care).
- **Parity Error** – triggers if the (odd) parity bit is incorrect for the data in the word.
- **Sync Error** – triggers if an invalid Sync pulse is found.
- **Manchester Error** – triggers if a Manchester encoding error is detected.

### NOTE

For MIL-STD-1553 decode information see "[MIL-STD-1553 Serial Decode](#)" on page 384.

## MIL-STD-1553 Serial Decode

To set up the oscilloscope to capture MIL-STD-1553 signals, see ["Setup for MIL-STD-1553 Signals"](#) on page 382.

### NOTE

For MIL-STD-1553 triggering setup see ["MIL-STD-1553 Triggering"](#) on page 383.

To set up MIL-STD-1553 serial decode:

- 1 Choose **Main Menu > Analyze > Serial Decode** to display the Serial Decode Menu.



- 2 Use the **Base** softkey to select between hexadecimal and binary display of the decoded data.

The base setting is used for the display of the remote terminal address and the data, in both the decode line and in the Lister.

- 3 If the decode line does not appear on the display, choose **Main Menu > Analyze > Serial Decode** again to turn it on.
- 4 If the oscilloscope is stopped, choose **Main Menu > Run/Stop** to acquire and decode data.

You can use the horizontal **Zoom** window for easier navigation of the decoded data.

- See Also**
- ["Interpreting MIL-STD-1553 Decode"](#) on page 384
  - ["Interpreting MIL-STD-1553 Lister Data"](#) on page 386
  - ["Searching for MIL-STD-1553 Data in the Lister"](#) on page 387

## Interpreting MIL-STD-1553 Decode

To display serial decode information after turning on serial decode, you must choose **Main Menu > Run/Stop** to start making acquisitions or **Main Menu > Single** to make a single acquisition.



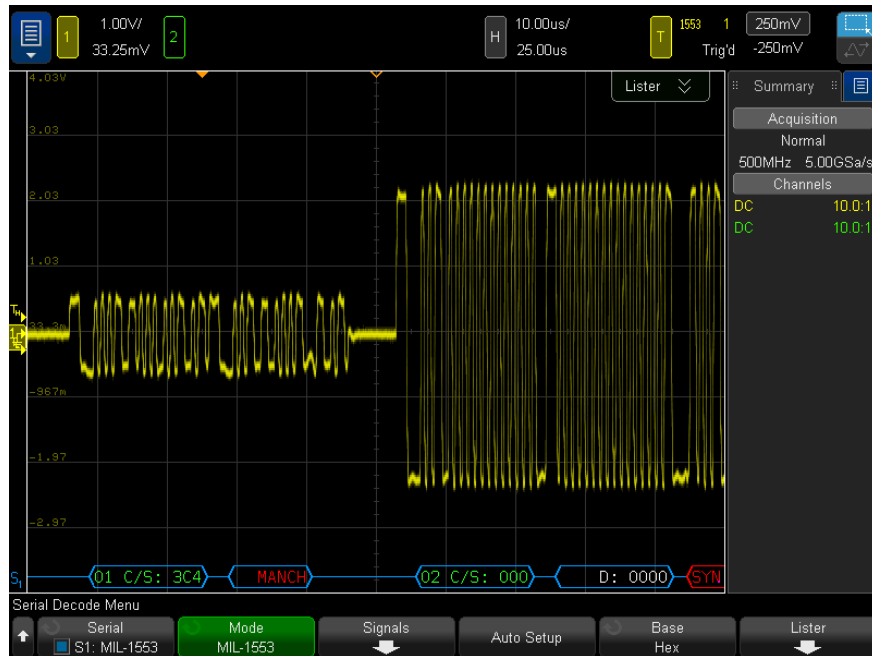

The MIL-STD-1553 decode display is color coded as follows:

- Command and Status decoded data is colored green, with the Remote Terminal Address (5 bits of data) being displayed first, then the text "C/S:", followed by the value of the remaining 11 bits of a Command/Status word.
- Data word decoded data is colored white, preceded by the text "D:".
- Command/Status or Data words with a Parity error have the decode text displayed in red instead of green or white.
- SYNC errors are displayed with the word "SYNC" within red angle brackets.
- Manchester encoding errors are displayed with the word "MANCH" within blue angle brackets (blue instead of red because a valid Sync pulse started the word).

## Interpreting MIL-STD-1553 Lister Data

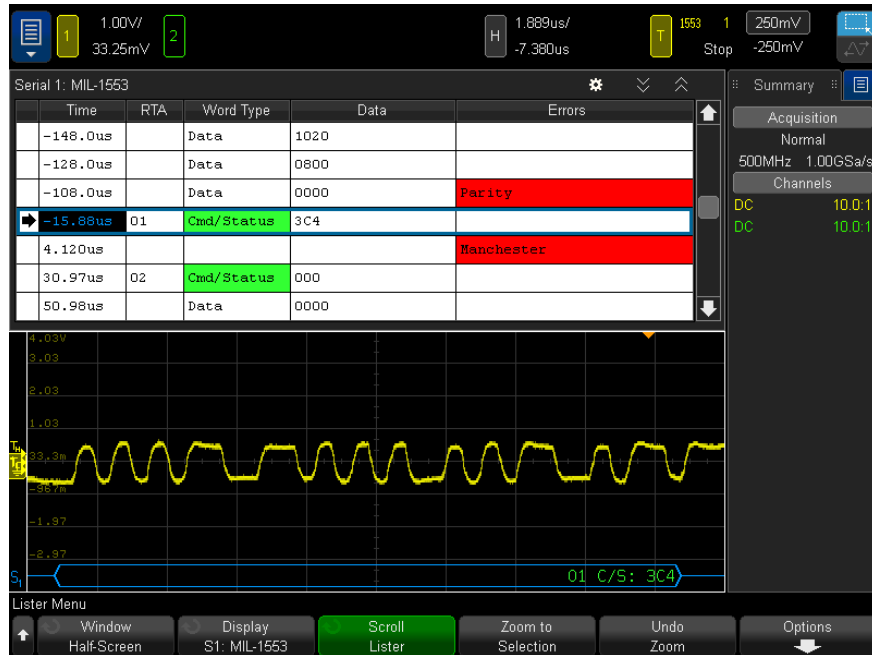

In addition to the standard Time column, the MIL-STD-1553 Lister contains these columns:

- RTA – displays the Remote Terminal Address for Command/Status words, nothing for Data words.
- Word Type – "Cmd/Status" for Command/Status words, "Data" for Data words. For Command/Status words the background color is green to match the decode text color.
- Data – the 11 bits after the RTA for Command/Status words, or the 16 bits of a Data word.
- Errors – "Sync", "Parity", or "Manchester" errors as appropriate. The background color is red to indicate an error.

Aliased data is highlighted in pink. When this happens, decrease the horizontal time/div setting and run again.

## Searching for MIL-STD-1553 Data in the Lister

The oscilloscope's search capability lets you search for (and mark) certain types of MIL-STD-1553 data in the Lister. You can use the sidebar **Navigate** controls to navigate through the marked rows.

- 1 With MIL-STD-1553 selected as the serial decode mode, choose **Main Menu > Analyze > Waveform Search**.
- 2 In the Search Menu, click the **Search** softkey; then, select Serial 1 or Serial 2 on which the MIL-STD-1553 signal is being decoded.
- 3 Click **Search for**; then, select from these options:
  - **Data Word Start** – finds the start of a Data word (at the end of a valid Data Sync pulse).
  - **Command/Status Word Start** – finds the start of Command/Status word (at the end of a valid C/S Sync pulse).
  - **Remote Terminal Address** – finds the Command/Status word whose RTA matches the specified value. The value is specified in hex.

When this option is selected, the **RTA** softkey becomes available and lets you select the hex Remote Terminal Address value to find.

- **Remote Terminal Address + 11 Bits** – finds the RTA and the remaining 11 bits that match the specified criteria.

When this option is selected, these softkeys become available:

- The **RTA** softkey lets you select the hex Remote Terminal Address value.
- The **Bit Time** softkey lets you select the bit time position.
- The **0 1 X** softkey lets you set the bit time position value as a 1, 0, or X (don't care).
- **Parity Error** – finds (odd) parity bits that are incorrect for the data in the word.
- **Sync Error** – finds invalid Sync pulses.
- **Manchester Error** – finds Manchester encoding errors.

For more information on searching data, see "[Searching Lister Data](#)" on page 109.

For more information on using the sidebar **Navigate** controls, see "[Navigating the Time Base](#)" on page 49.

## Setup for ARINC 429 Signals

Setup consists of first connecting the oscilloscope to a ARINC 429 signal using a differential active probe (the Keysight N2791A is recommended), then using the Signals Menu to specify the signal source, the high and low trigger threshold voltage levels, the signal speed, and the signal type.

To set up the oscilloscope to capture ARINC 429 signals:

- 1 Choose **Main Menu > Analyze > Serial Decode**.
- 2 Click the **Serial** softkey, select Serial 1 or Serial 2, and click the softkey again to enable decode.
- 3 Click the **Mode** softkey; then, select **ARINC 429**.
- 4 Click the **Signals** softkey to open the ARINC 429 Signals Menu.



- 5 Click **Source**; then, select the channel for the ARINC 429 signal.  
The label for the ARINC 429 source channel is automatically set.
- 6 Click the **Speed** softkey to open the ARINC 429 Speed Menu.



- 7 In the ARINC429 Speed Menu, click the **Speed** softkey and specify the speed of the ARINC 429 signal:
  - **High** – 100 kb/s.
  - **Low** – 12.5 kb/s.
  - **User Defined** – click the **User Baud** softkey and enter the user-defined speed value.
- 8 Click the  Back/Up softkey to return to the ARINC 429 Signals Menu.
- 9 Click the **Signal Type** softkey and specify the signal type of the ARINC 429 signal:
  - **Line A (non-inverted)**.
  - **Line B (inverted)**.
  - **Differential (A-B)**.
- 10 Click the **Auto Setup** softkey to automatically set these options for decoding and triggering on ARINC 429 signals:
  - High Trigger Threshold: 3.0 V.

- Low Trigger Threshold: -3.0 V.
- Noise Reject: Off.
- Probe Attenuation: 10.0.
- Vertical Scale: 4 V/div.
- Serial Decode: On.
- Base: Hex.
- Word Format: Label/SDI/Data/SSM.
- Trigger: currently active serial bus.
- Trigger Mode: Word Start.

**11** If the high and low thresholds are not set correctly by **Auto Setup**:

- Click the **High Threshold** softkey; then, enter the high trigger threshold voltage level.
- Click the **Low Threshold** softkey; then, enter the low trigger threshold voltage level.

The threshold voltage levels are used in decoding and will become the trigger levels when the trigger type is set to the selected serial decode slot.

## ARINC 429 Triggering

To set up the oscilloscope to capture a ARINC 429 signal, see "[Setup for ARINC 429 Signals](#)" on page 388.

After setting up the oscilloscope to capture a ARINC 429 signal:

- 1 Choose **Main Menu > Trigger > Trigger Menu**.
- 2 In the Trigger Menu, click the **Trigger Type** softkey; then, select Serial 1 or Serial 2 on which the ARINC 429 signal is being decoded.



- 3 Click the **Trigger:** softkey; then, select the trigger condition:
  - **Word Start** – triggers on the start of a word.
  - **Word Stop** – triggers at the end of a word.
  - **Label** – triggers on the specified label value.
  - **Label + Bits** – triggers on the label and the other word fields as specified.
  - **Label Range** – triggers on a label following in a min/max range.
  - **Parity Error** – triggers on words with a parity error.
  - **Word Error** – triggers on an intra-word coding error.
  - **Gap Error** – triggers on an inter-word gap error.
  - **Word or Gap Error** – triggers on either a Word or Gap Error.
  - **All Errors** – triggers on any of the above errors.
  - **All Bits (Eye)** – triggers on any bit, which will therefore form an eye diagram.
  - **All 0 Bits** – triggers on any bit with a value of zero.
  - **All 1 Bits** – triggers on any bit with a value of one.
- 4 If you select the **Label** or **Label + Bits** condition, use the **Label** softkey to specify the label value.

Label values are always displayed in octal.

- 5 If you select the **Label + Bits** condition, use the **Bits** softkey and submenu to specify the bit values:



Click the **Data**, **SSM**, and/or **SSM** softkeys and use the binary keypad dialog to enter the 0, 1, or X (don't care) values.

The SDI or SSM selections may not be available, depending on word format selection in the Serial Decode Menu.

- 6 If you select the **Label Range** condition, use the **Label Min** and **Label Max** softkeys to specify the ends of the range.

Again, label values are always displayed in octal.

You can use the **Zoom** mode for easier navigation of the decoded data.

**NOTE**

To display ARINC 429 serial decode, see "[ARINC 429 Serial Decode](#)" on page 392.

---

## ARINC 429 Serial Decode

To set up the oscilloscope to capture ARINC 429 signals, see "[Setup for ARINC 429 Signals](#)" on page 388.

### NOTE

For ARINC 429 triggering set up see "[ARINC 429 Triggering](#)" on page 390.

To set up ARINC 429 serial decode:

- 1 Choose **Main Menu > Analyze > Serial Decode** to display the Serial Decode Menu.



- 2 In the submenu accessed by the **Settings** softkey, you can use the **Base** softkey to select between hexadecimal and binary display of the decoded data.

The base setting is used for *data* display in both the decode line and in the Lister.

Label values are always displayed in octal, and SSM and SDI values are always displayed in binary.

- 3 Click the **Word Format** softkey and specify the word decode format:
  - **Label/SDI/Data/SSM:**
    - Label - 8 bits.
    - SDI - 2 bits.
    - Data - 19 bits.
    - SSM - 2 bits.
  - **Label/Data/SSM:**
    - Label - 8 bits.
    - Data - 21 bits.
    - SSM - 2 bits.
  - **Label/Data:**
    - Label - 8 bits.
    - Data - 23 bits.
- 4 If the decode line does not appear on the display, choose **Main Menu > Analyze > Serial Decode** again to turn it on.
- 5 If the oscilloscope is stopped, choose **Main Menu > Run/Stop** to acquire and decode data.



**NOTE**

If the setup does not produce a stable trigger, the ARINC 429 signal may be slow enough that the oscilloscope is AutoTriggering. Click the Run/Stop status in the upper-right corner of the display, and change the trigger mode from **Auto** to **Normal**.

You can use the horizontal **Zoom** window for easier navigation of the decoded data.

- See Also
- ["Interpreting ARINC 429 Decode"](#) on page 393
  - ["ARINC 429 Totalizer"](#) on page 394
  - ["Interpreting ARINC 429 Lister Data"](#) on page 395
  - ["Searching for ARINC 429 Data in the Lister"](#) on page 395

## Interpreting ARINC 429 Decode

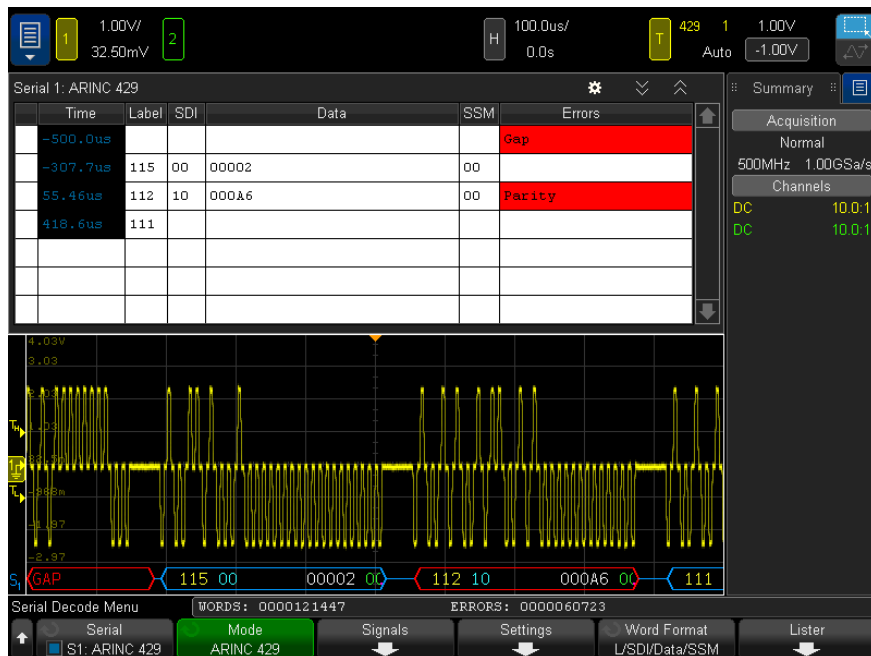

Depending on the selected word decode format, the ARINC 429 decode display is color coded as follows:

- When the decode format is Label/SDI/Data/SSM:
  - Label (yellow) (8 bits) – displayed in octal.
  - SDI (blue) (2 bits) – displayed in binary.
  - Data (white, red if parity error) (19 bits) – displayed in the selected Base.
  - SSM (green) (2 bits) – displayed in binary.
- When the decode format is Label/Data/SSM:
  - Label (yellow) (8 bits) – displayed in octal.

- Data (white, red if parity error) (21 bits) – displayed in the selected Base.
- SSM (green) (2 bits) – displayed in binary.
- When the decode format is Label/Data:
  - Label (yellow) (8 bits) – displayed in octal.
  - Data (white, red if parity error) (23 bits) – displayed in the selected Base.

The Label bits are displayed in the same order as they are received on the wire. For the Data, SSM, and SDI bits, the fields are displayed in the order received; however, the bits within those fields are displayed in reverse order. In other words, the non-Label fields are displayed in the ARINC 429 Word Format, while the bits for those fields have the opposite transfer order on the wire.

## ARINC 429 Totalizer

The ARINC 429 totalizer measures the total ARINC 429 words and errors.



The totalizer is always running, counting words and errors, and is displayed whenever ARINC 429 decode is displayed. The totalizer counts even when the oscilloscope is stopped (not acquiring data).

Stopping acquisitions does not affect the totalizer.

When an overflow condition occurs, the counter displays **OVERFLOW**.

The counters can be reset to zero by clicking the **Reset ARINC 429 Counters** softkey (in the decode **Settings** menu).

## Interpreting ARINC 429 Lister Data

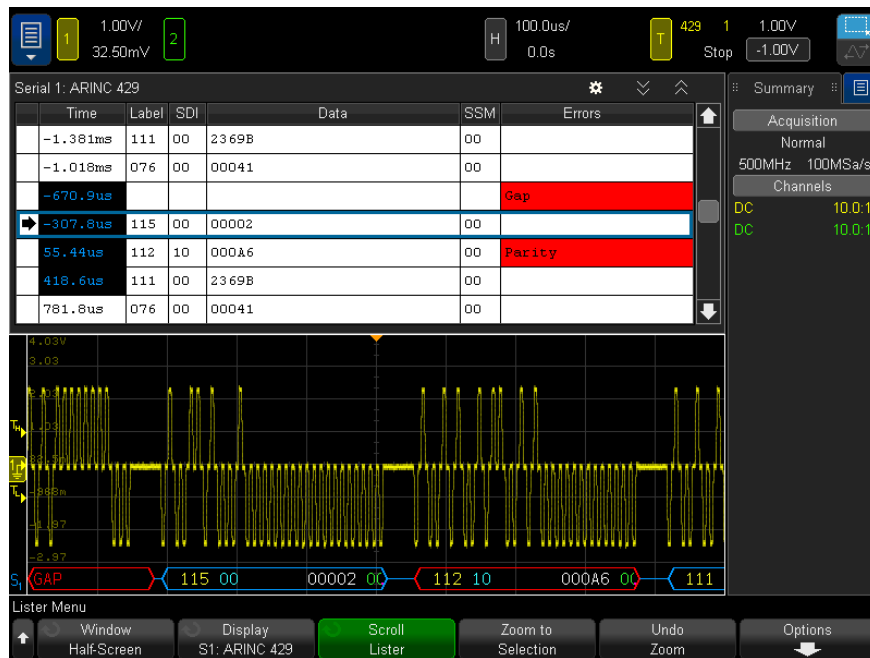

In addition to the standard Time column, the ARINC 429 Lister contains these columns:

- Label – the 5-bit label value in octal format.
- SDI – the bit values (if included in the word decode format).
- Data – the data value in binary or hex, depending on the base setting.
- SSM – the bit values (if included in the word decode format).
- Errors – highlighted in red. Errors can be Parity, Word, or Gap.

Aliased data is highlighted in pink. When this happens, decrease the horizontal time/div setting and run again.

## Searching for ARINC 429 Data in the Lister

The oscilloscope's search capability lets you search for (and mark) certain types of ARINC 429 data in the Lister. You can use the sidebar **Navigate** controls to navigate through the marked rows.

- 1 With ARINC 429 selected as the serial decode mode, choose **Main Menu > Analyze > Waveform Search**.
- 2 In the Search Menu, click the **Search** softkey; then, select Serial 1 or Serial 2 on which the ARINC 429 signal is being decoded.
- 3 Click **Search**; then, select from these options:

- **Label** – finds the specified label value.  
Label values are always displayed in octal.
- **Label + Bits** – finds the label and the other word fields as specified.
- **Parity Error** – finds words with a parity error.
- **Word Error** – finds an intra-word coding error.
- **Gap Error** – finds an inter-word gap error.
- **Word or Gap Error** – finds either a Word or Gap Error.
- **All Errors** – finds any of the above errors.

For more information on searching data, see "[Searching Lister Data](#)" on page 109.

For more information on using the sidebar **Navigate** controls, see "[Navigating the Time Base](#)" on page 49.

# 26 SENT Triggering and Serial Decode

Setup for SENT Signals / 398

SENT Triggering / 402

SENT Serial Decode / 404

SENT (Single Edge Nibble Transmission) triggering and serial decode requires the P9240NSA license.

## Setup for SENT Signals

To set up the oscilloscope to capture SENT signals:

- 1 Connect an oscilloscope channel to the signal in the device under test.  
Analog channels can be used.
- 2 Choose **Main Menu > Analyze > Serial Decode**.
- 3 Click the **Serial** softkey, select Serial 1 or Serial 2, and click the softkey again to enable decode.
- 4 Click the **Mode** softkey; then, select **SENT**.
- 5 Click the **Source** softkey to open the SENT Source Menu.



- a Click the **Source** softkey; then, select the channel for the signal.
  - b Click the **Threshold** softkey; then, select the signal threshold voltage level.  
The threshold voltage level is used in decoding, and it will become the trigger level when the trigger type is set to the selected serial decode (Serial 1 or Serial 2).
  - c Click the  Back/Up softkey to return to the SENT Serial Decode Menu.
- 6 Click the **Bus Config** softkey to open the SENT Bus Configuration Menu.

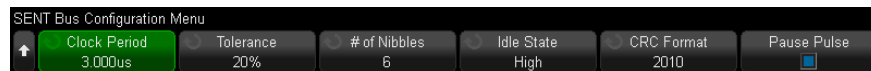

- a Click the **Clock Period** softkey; then, specify the nominal clock period (tick) time.
- b Click the **Tolerance** softkey; then, specify the percent tolerance for determining whether the sync pulse is valid for decoding the data.  
If the measured time of the sync pulse is within the percent tolerance of the nominal clock period setting, the decode proceeds; otherwise, the sync pulse is in error, and the data is not decoded.
- c Click the **# of Nibbles** softkey; then, specify the number of nibbles in a Fast Channel Message.
- d Click the **Idle State** softkey to specify the idle state of the SENT signal.
- e Click the **CRC Format** softkey to specify the CRC format that will be used in calculating the correctness of the CRCs.

Enhanced Serial Message CRCs are always calculated using the 2010 format, but for the Fast Channel Messages, and for Short Serial Message CRCs, the chosen setting is used.

- f Click the **Pause Pulse** softkey to specify whether there is a pause pulse between Fast Channel Messages.

- **Off** – There is no pause pulse between Fast Channel Messages.

Note that a SENT serial bus with no pause pulse is never idle. This means, during normal operation, the fast channel decode line will show a continuous stream of packets, with a new packet opening as soon as the previous one has closed.

- **On** – Pause pulses are added between Fast Channel Messages so that frames come at a regular interval.

If there is a pause pulse (and **Pause Pulse** is on), idle time is shown between messages.

- **SPC** (Short PWM Code) – In SENT SPC, there are no pause pulses. Instead, the message event is triggered by the master when it wants to receive data. SENT SPC ends the transmission after the CRC so it almost appears as if there is a pause pulse from the end until the next master trigger.

- g Click the  Back/Up softkey to return to the SENT Serial Decode Menu.

- 7 Click the **Settings** softkey to open the SENT Settings Menu.

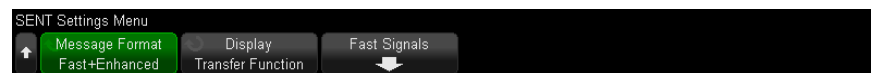

- a Click the **Message Format** softkey to select the message decode/triggering format:

- **Fast Nibbles (All)** – displays the raw transmitted nibble values.
- **Fast Signals** – displays Fast Channel Message Signals.
- **Fast + Short Serial** – displays both Fast and Slow Messages (Short format) simultaneously.
- **Fast + Enhanced Serial** – displays both Fast and Slow Messages (Enhanced format) simultaneously.
- **Short Serial** – displays Slow Channel Messages in Short format.
- **Enhanced Serial** – displays Slow Channel Messages in Enhanced format.

This selection affects both decoding and triggering. The decode is affected both in how the system interprets the data, and what will be displayed. The trigger is affected in that the trigger hardware needs to be configured to trigger on serial messages correctly.

You can specify the nibble display order for Fast Channel Message Signals (under the **Fast Signals** softkey). Raw transmitted nibble values are displayed in the order received.

**NOTE**

For the Slow Channel, the proper format, Short or Enhanced, must be chosen for proper decoding and triggering to occur.

Slow Channel Serial Messages are always displayed as defined by the SENT specification.

- b Click the **Display** softkey to select between hexadecimal, unsigned decimal, or "transfer function" display of Fast Channel nibbles, signals, and CRC values, as well as Slow Channel IDs, data, and CRC values. (The S&C value is always displayed in binary.)

Your selection is used for both the Lister and the decode line displays.

When **Transfer Function** is selected (for message formats that include fast signals), Fast Channel Signals display a calculated physical value based on the specified **Multiplier** and **Offset** (under the **Fast Signals** softkey):

$$\text{PhysicalValue} = (\text{Multiplier} * \text{SignalValueAsUnsignedInteger}) + \text{Offset}$$

When **Transfer Function** is selected, the CRC and Slow Channel information is displayed in hex.

- 8 When a fast signals message decode/triggering is selected, click the **Fast Signals** softkey to open the SENT Signals Menu where you can define and specify the display of up to six Fast Signals.



- a Click the **Fast Signals** softkey and select the Fast Signal to be defined.  
Once a Fast Signal is selected, click the softkey again to enable or disable decode for that signal.
- b Click the **Start Bit # (MSB)** softkey to specify the starting bit for the selected signal.
- c Click the **# of Bits** softkey to specify the number of bits in the selected signal.
- d Click the **Nibble Order** softkey to specify the nibble display order as either most significant nibble (MSN) or least significant nibble (LSN) first.
- e When the display mode setting is **Transfer Function** (see the SENT Settings Menu), click the **Multiplier** or **Offset** softkeys; then, specify the value.

The multiplier and offset values are used in calculating a physical value displayed for the Fast Signal:



·  $PhysicalValue = (Multiplier * SignalValueAsUnsignedInteger) + Offset$

Here are some Fast Signal definition examples:

**Example 1: Start Bit # = 13, # of bits = 8, Nibble Order = LSN First**

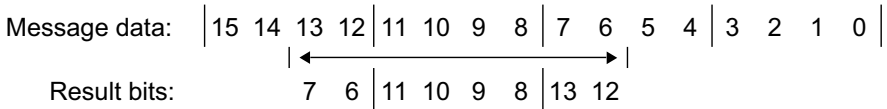

**Example 2: Start Bit # = 10, # of bits = 5, Nibble Order = MSN First**

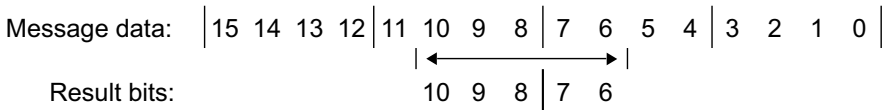

## SENT Triggering

To set up the oscilloscope to capture SENT signals, see "[Setup for SENT Signals](#)" on page 398.

To set up a SENT trigger condition:

- 1 Choose **Main Menu > Trigger > Trigger Menu**.
- 2 In the Trigger Menu, click the **Trigger Type** softkey; then, select the serial decode (Serial 1 or Serial 2) of the SENT signal.



- 3 Click the **Trigger on:** softkey and select the SENT trigger condition:
  - **Start of Fast Channel Message** – triggers on the start of any Fast Channel Message (after 56 Synchronization/Calibration ticks).
  - **Start of Slow Channel Message** – trigger on the start of any Slow Channel Message.
  - **Fast Channel SC & Data** – triggers on a Fast Channel Message when the Status & Communication nibble and the data nibbles match the values entered using additional softkeys.
  - **Slow Channel Message ID** – triggers when a Slow Channel Message ID matches the value entered using additional softkeys.
  - **Slow Channel Message ID & Data** – triggers when a Slow Channel Message ID and Data field both match the values entered using additional softkeys.
  - **Tolerance Violation** – triggers when the sync pulse width varies from the nominal value by greater than the entered percentage.
  - **Fast Channel CRC Error** – triggers on any Fast Channel Message CRC error.
  - **Slow Channel CRC Error** – triggers on any Slow Channel Message CRC error.
  - **All CRC Errors** – triggers on any CRC error, Fast or Slow.
  - **Pulse Period Error** – triggers if a nibble is either too wide or too narrow (for example, data nibble < 12 (11.5) or > 27 (27.5) ticks wide). Sync, S&C, data, or checksum pulse periods are checked.
  - **Successive Sync Pulses Error** – triggers on a sync pulse whose width varies from the previous sync pulse's width by greater than 1/64 (1.5625%, as defined in the SENT specification).

- 4 If you choose the **Fast Channel SC & Data** trigger condition:
  - a Click the **Base** softkey to choose between Hex or Binary data value entry.
 

Use the Binary method if you need to enter "don't care" bits (X) within a nibble. If all bits in a nibble are "don't care", the hex nibble is displayed as "don't care" (X). When all bits in a nibble are 1s or 0s, the hex value is shown. Hex nibbles that contain a mix of 0/1 bits and "don't care" bits are displayed as "\$".
  - b Click the **SC & Data** softkey and use the keypad dialog to enter the data value.
 

The S&C nibble is the left most nibble entered in the string of numbers, followed by the data nibbles.
- 5 If you choose the **Slow Channel Message ID** or **Slow Channel Message ID & Data** trigger condition:
  - a Click the **Configuration** softkey to select the desired packet ID for the selected packet type.
 

When an Enhanced Serial message format is specified (see "**Setup for SENT Signals**" on page 398), click this softkey to select which enhanced format configuration is being used:

    - 16-Bit Data, 4-Bit ID
    - 12-Bit Data, 8-Bit ID
  - b Click the **Slow Message ID** softkey and specify the Slow Message ID.
  - c If you choose the **Slow Channel Message ID & Data** trigger condition, click the **Slow Data** softkey and specify the Slow Message data.
- 6 If you choose the **Tolerance Violation** trigger condition, click the **Tolerance** softkey and specify the tolerance variation that is considered a violation.
 

The percentage entered must be less than the percent tolerance specified in the decode bus configuration settings.

**NOTE**

If the setup does not produce a stable trigger, the SENT signals may be slow enough that the oscilloscope is AutoTriggering. Click the Run/Stop status in the upper-right corner of the display, and change the trigger mode from **Auto** to **Normal**.

**NOTE**

To display SENT serial decode, see "**SENT Serial Decode**" on page 404.

## SENT Serial Decode

To set up the oscilloscope to capture SENT signals, see "[Setup for SENT Signals](#)" on page 398.

### NOTE

For SENT triggering setup see "[SENT Triggering](#)" on page 402.

To set up SENT serial decode:

- 1 Choose **Main Menu > Analyze > Serial Decode** to display the Serial Decode Menu.

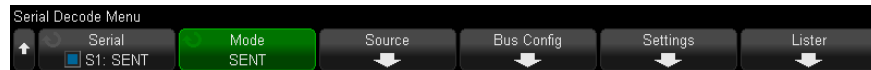

- 2 If the decode line does not appear on the display, choose **Main Menu > Analyze > Serial Decode** again to turn it on.
- 3 If the oscilloscope is stopped, choose **Main Menu > Run/Stop** to acquire and decode data.

### NOTE

If the setup does not produce a stable trigger, the SENT signals may be slow enough that the oscilloscope is AutoTriggering. Click the Run/Stop status in the upper-right corner of the display, and change the trigger mode from **Auto** to **Normal**.

You can use the horizontal **Zoom** window for easier navigation of the acquired data.

- See Also
- "[Interpreting SENT Decode](#)" on page 404
  - "[Interpreting SENT Lister Data](#)" on page 407
  - "[Searching for SENT Data in the Lister](#)" on page 408

## Interpreting SENT Decode

The fields of the Fast and Slow Channels are displayed as follows. Note that the Slow Channel has three different variants. The colors noted below indicate the color of the text:

- Fast Channel:

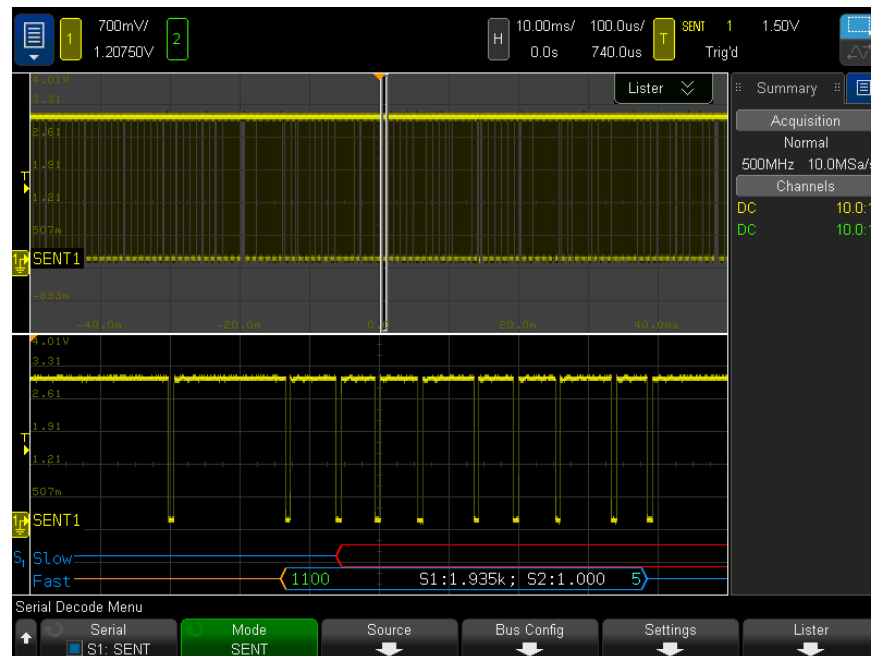

- Status & Communication (S&C) Nibble (green) (4 bits):
  - 2 Application bits and 2 Serial Message bits will be displayed, in all formats.
- Data Nibbles (white) (4 bits, but may be combined into Signals, based on format):
  - **"Fast Nibbles (All)"** format – each nibble displayed as hex or decimal number.
  - **"Fast Signals"**, **"Fast + Short Serial"**, or **"Fast + Enhanced Serial"** formats – If any fast signals are enabled, signals are displayed like:
    - S1:<value>;S2:<value>.
    - Unused nibbles are not displayed (example, when 6th nibble is an inverted copy of the 1st nibble).
- CRC Nibble (blue when valid, red when error detected) (4 bits).
- Slow Channel – Short Serial Message:
  - Message ID (yellow) (4 bits).
  - Data Byte (white) (8 bits).
  - CRC (blue when valid, red when error detected) (4 bits).

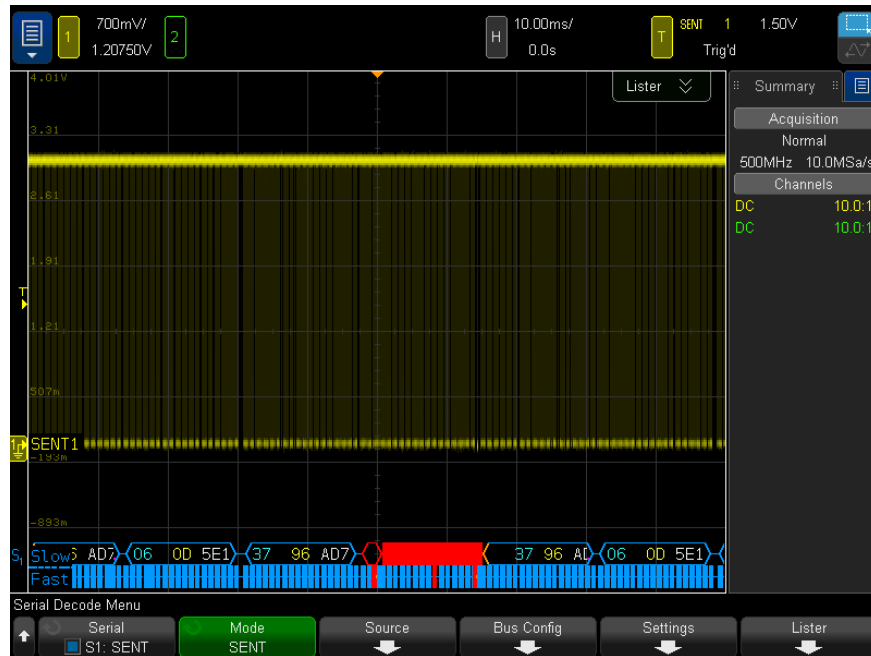

- Slow Channel – Enhanced Serial Message:
  - CRC (blue when valid, orange if end of message is off screen, red when error detected) (6 bits).
  - Message ID (yellow) (4 or 8 bits).
  - Data Field (white) (16 or 12 bits).

Enhanced Serial Message CRCs will be displayed in orange if the data to calculate the CRC is off-screen to the right. Serial messages will also be shown with a leading idle line in orange and an opening brace in orange if the starting location cannot be precisely determined due to that data being off screen to the left.

The decode will also indicate errors where a nibble's pulse is too wide or too narrow. This will be indicated by a ">" or "<" in red, as well as the rest of the packet's outline and closing brace being in red, as well as an orange idle line until the next valid sync. At the time of the valid sync, there will be an orange opening brace.

## Interpreting SENT Lister Data

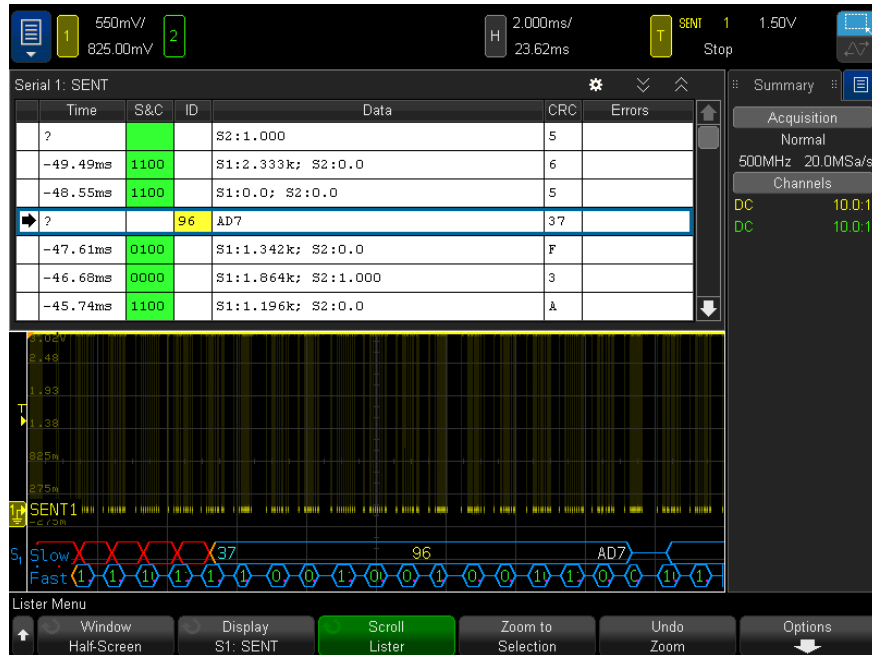

Each Fast or Slow Channel message is represented on its own row. The start time of Slow Channel messages determines their order relative to the Fast Channel messages. Therefore, a Slow Channel message appears before most of the Fast Channel messages that it was built from. This is due to the "Time" column holding the start time of a packet.

In addition to the standard Time column, the following columns are used to support both the Fast Channel and the Slow Channel simultaneously, and these columns are displayed for all Message Format modes except **Fast Nibbles (All)**:

- S&C – (Fast Channel Only) (binary).
- ID – (Slow Channel Only) (Hex or Decimal).
- Data – (Hex or Decimal):
  - Fast Channel:
    - <value> (value in Hex or Decimal) (Raw Decode Format).
    - S1:<value>;S2:<value> (values are in Hex or Decimal) (other formats).
  - Slow Channel: Hex or Decimal display of a single value.
- CRC – (value in Hex or Decimal).
- Pause Ticks (ticks will be displayed in orange if the uncertainty of the measurement is > 25%).
- Errors.

When the Message Format is set to **Fast Nibbles (All)**, the following columns are displayed:

- Sync Width.
- S&C – (Fast Channel Only) (binary).
- Data – (Hex or Decimal).
- CRC – (value in Hex or Decimal).
- Errors.

When the selected Message Format contains both Fast and Slow Channel Messages, the S&C Lister field (populated for Fast Messages) has a green background, and the ID Lister field (populated for Slow Messages) has a yellow background.

Slow Channel CRC values that cannot be confirmed as valid or invalid due to data used in the calculation being off screen to the right, will have an orange background in the Lister.

## Searching for SENT Data in the Lister

The oscilloscope's search capability lets you search for (and mark) certain types of SENT data in the Lister. You can use the sidebar **Navigate** controls to navigate through the marked rows.

- 1 With SENT selected as the serial decode mode, choose **Main Menu > Analyze > Waveform Search**.
- 2 In the Search Menu, click the **Search** softkey; then, select Serial 1 or Serial 2, where the SENT signals is being decoded.
- 3 In the Search Menu, click **Search for**; then, select from these options:
  - **Fast Channel Data** – finds Fast Channel data nibbles that match the values entered using additional softkeys.
  - **Slow Channel Message ID** – finds Slow Channel Message IDs that match the value entered using additional softkeys.
  - **Slow Channel Message ID & Data** – finds Slow Channel Message IDs and Data that match the values entered using additional softkeys.
  - **All CRC Errors** – finds any CRC error, Fast or Slow.
  - **Pulse Period Error** – finds where a nibble is either too wide or too narrow (for example, data nibble < 12 (11.5) or > 27 (27.5) ticks wide). Sync, S&C, data, or checksum pulse periods are checked.

For more information on searching data, see "[Searching Lister Data](#)" on page 109.

For more information on using the sidebar **Navigate** controls, see "[Navigating the Time Base](#)" on page 49.



# 27 UART/RS232 Triggering and Serial Decode

Setup for UART/RS232 Signals / 410

UART/RS232 Triggering / 412

UART/RS232 Serial Decode / 414

UART/RS232 triggering and serial decode requires the COMP license that you can get by purchasing the P9240CMPA upgrade.

## Setup for UART/RS232 Signals

To set up the oscilloscope to capture UART/RS232 signals:

- 1 Choose **Main Menu > Analyze > Serial Decode**.
- 2 Click the **Serial** softkey, select Serial 1 or Serial 2, and click the softkey again to enable decode.
- 3 Click the **Mode** softkey; then, select **UART/RS232**.
- 4 Click the **Signals** softkey to open the UART/RS232 Signals Menu.



- 5 For both the Rx and Tx signals:
  - a Connect an oscilloscope channel to the signal in the device under test.
  - b Click the **Rx** or **Tx** softkey; then, select the channel for the signal.
  - c Click the corresponding **Threshold** softkey; then, select the signal threshold voltage level.

The threshold voltage level is used in decoding, and it will become the trigger level when the trigger type is set to the selected serial decode slot.

The RX and TX labels for the source channels are automatically set.

- 6 Click the  Back/Up softkey to return to the Serial Decode Menu.
- 7 Click the **Bus Config** softkey to open the UART/RS232 Bus Configuration Menu.



Set the following parameters.

- a **#Bits** – Set the number of bits in the UART/RS232 words to match your device under test (selectable from 5–9 bits).
- b **Parity** – Choose odd, even, or none, based on your device under test.
- c **Baud** – Click the **Baud Rate** softkey, then click the **Baud** softkey and select a baud rate to match the signal in your device under test. You can select baud rates from 1.2 kb/s to 12 Mb/s.

If the desired baud rate is not listed, select **User Defined** on the Baud softkey; then, select the desired baud rate using the **User Baud** softkey. You can set the user-defined UART baud rate from 100 b/s to 8.0000 Mb/s.

- d Polarity** – Select idle low or idle high to match your device under test's state when at idle. For RS232 select idle low.
- e Bit Order** – Select whether the most significant bit (MSB) or the least significant bit (LSB) is presented after the start bit in the signal from your device under test. For RS232 select LSB.

**NOTE**

In the serial decode display, the most significant bit is always displayed on the left regardless of how Bit Order is set.

---

## UART/RS232 Triggering

To set up the oscilloscope to capture UART/RS-232 signals, see "[Setup for UART/RS232 Signals](#)" on page 410.

To trigger on a UART (Universal Asynchronous Receiver/Transmitter) signal connect the oscilloscope to the Rx and Tx lines and set up a trigger condition. RS232 (Recommended Standard 232) is one example of a UART protocol.

- 1 Choose **Main Menu > Trigger > Trigger Menu**.
- 2 In the Trigger Menu, click the **Trigger Type** softkey; then, select Serial 1 or Serial 2 on which the UART/RS232 signals are being decoded.



- 3 Click the **Trigger Setup** softkey to open the UART/RS232 Trigger Setup Menu.



- 4 Click the **Base** softkey to select Hex or ASCII as the base displayed on the Data softkey in the UART/RS232 Trigger Setup Menu.

Note that the setting of this softkey does not affect the selected base of the decode display.

- 5 Click the **Trigger** softkey and set up the desired trigger condition:
  - **Rx Start Bit** – The oscilloscope triggers when a start bit occurs on Rx.
  - **Rx Stop Bit** – Triggers when a stop bit occurs on Rx. The trigger will occur on the first stop bit. This is done automatically whether the device under test uses 1, 1.5, or 2 stop bits. You do not need to specify the number of stop bits used by the device Under test.
  - **Rx Data** – Triggers on a data byte that you specify. For use when the device under test data words are from 5 to 8 bits in length (no 9th (alert) bit).
  - **Rx 1:Data** – For use when the device under test data words are 9 bits in length including the alert bit (the 9th bit). Triggers only when the 9th (alert) bit is 1. The specified data byte applies to the least significant 8 bits (excludes the 9th (alert) bit).
  - **Rx 0:Data** – For use when the device under test data words are 9 bits in length including the alert bit (the 9th bit). Triggers only when the 9th (alert) bit is 0. The specified data byte applies to the least significant 8 bits (excludes the 9th (alert) bit).

- **Rx X:Data** – For use when the device under test data words are 9 bits in length including the alert bit (the 9th bit). Triggers on a data byte that you specify regardless of the value of the 9th (alert) bit. The specified data byte applies to the least significant 8 bits (excludes the 9th (alert) bit).
  - Similar choices are available for Tx.
  - **Rx or Tx Parity Error** – Triggers on a parity error based on the parity you have set in the Bus Configuration Menu.
- 6 If you choose a trigger condition that includes "**Data**" in its description (for example: **Rx Data**), then click the **Data is** softkey, and choose an equality qualifier. You can choose equal to, not equal to, less than, or greater than a specific data value.
  - 7 Use the **Data** softkey to choose the data value for your trigger comparison. This works in conjunction with the **Data is** softkey.
  - 8 Optional: The **Burst** softkey lets you trigger on the Nth frame (1-4096) after an idle time you select. All trigger conditions must be met for the trigger to occur.
  - 9 If **Burst** is selected, an idle time (1  $\mu$ s to 10 s) can be specified so that the oscilloscope will look for a trigger condition only after the idle time has past. Click the **Idle** softkey and set an idle time.

**NOTE**

If the setup does not produce a stable trigger, the UART/RS232 signals may be slow enough that the oscilloscope is AutoTriggering. Click the Run/Stop status in the upper-right corner of the display, and change the trigger mode from **Auto** to **Normal**.

---

**NOTE**

To display UART/RS232 serial decode, see "**UART/RS232 Serial Decode**" on page 414.

---

## UART/RS232 Serial Decode

To set up the oscilloscope to capture UART/RS232 signals, see "[Setup for UART/RS232 Signals](#)" on page 410.

### NOTE

For UART/RS232 triggering setup see "[UART/RS232 Triggering](#)" on page 412.

To set up UART/RS232 serial decode:

- 1 Choose **Main Menu > Analyze > Serial Decode** to display the Serial Decode Menu.



- 2 Click **Settings**.
- 3 In the UART/RS232 Settings Menu, click the **Base** softkey to select the base (hex, binary, or ASCII) in which decoded words are displayed.



- When displaying words in ASCII, the 7-bit ASCII format is used. Valid ASCII characters are between 0x00 and 0x7F. To display in ASCII you must select at least 7 bits in the Bus Configuration. If ASCII is selected and the data exceeds 0x7F, the data is displayed in hex.
  - When **#Bits** is set to 9 in the UART/RS232 Bus Configuration Menu, the 9th (alert) bit is displayed directly to the left of the ASCII value (which is derived from the lower 8 bits).
- 4 Optional: Click the **Framing** softkey and select a value. In the decode display, the chosen value will be displayed in light blue. However, if a parity error occurs the data will be displayed in red.
  - 5 If the decode line does not appear on the display, choose **Main Menu > Analyze > Serial Decode** again to turn it on.
  - 6 If the oscilloscope is stopped, choose **Main Menu > Run/Stop** to acquire and decode data.

### NOTE

If the setup does not produce a stable trigger, the UART/RS232 signals may be slow enough that the oscilloscope is AutoTriggering. Click the Run/Stop status in the upper-right corner of the display, and change the trigger mode from **Auto** to **Normal**.

You can use the horizontal **Zoom** window for easier navigation of the acquired data.

- See Also
- ["Interpreting UART/RS232 Decode"](#) on page 415
  - ["UART/RS232 Totalizer"](#) on page 416
  - ["Interpreting UART/RS232 Lister Data"](#) on page 416
  - ["Searching for UART/RS232 Data in the Lister"](#) on page 417

## Interpreting UART/RS232 Decode

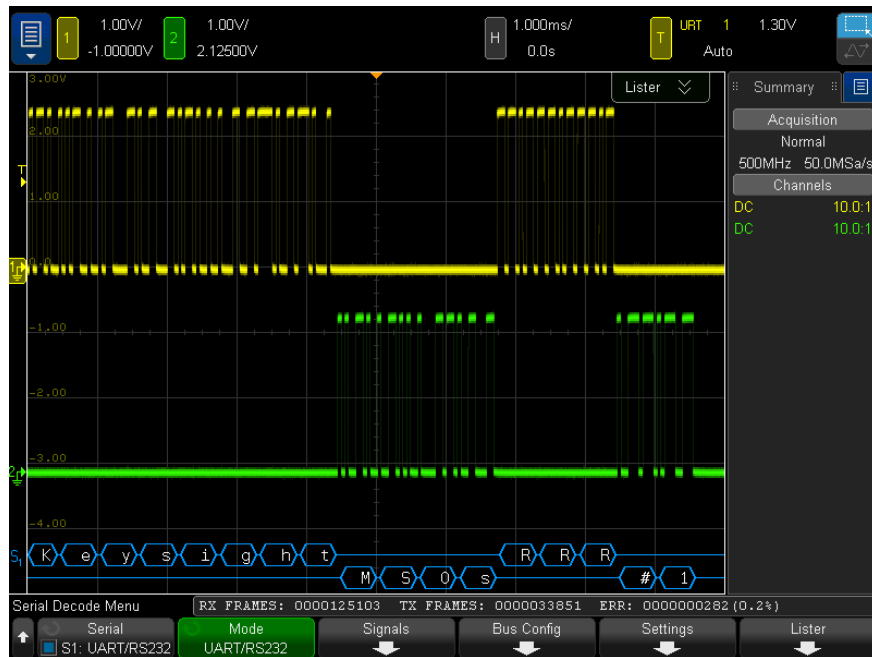

- Angled waveforms show an active bus (inside a packet/frame).
- Mid-level blue lines show an idle bus.
- When using 5–8 bit formats, the decoded data is displayed in white (in binary, hex, or ASCII).
- When using the 9 bit format, all data words are displayed in green, including the 9th bit. The 9th bit is displayed on the left.
- When a data word value is selected for framing, it is displayed in light blue. When using 9-bit data words, the 9th bit will also be displayed in light blue.
- Decoded text is truncated at the end of the associated frame when there is insufficient space within frame boundaries.
- Pink vertical bars indicate you need to expand the horizontal scale (and run again) to see decode.
- When the horizontal scale setting does not permit the display of all available decoded data, red dots will appear in the decoded bus to mark the location of hidden data. Expand the horizontal scale to allow the data to display.

- An unknown (undefined) bus is shown in red.
- A parity error will cause the associated data word to be shown in red, which includes the 5-8 data bits and the optional 9th bit.

## UART/RS232 Totalizer

The UART/RS232 totalizer consists of counters that provide a direct measure of bus quality and efficiency. The totalizer appears on screen whenever UART/RS232 Decode is ON in the Serial Decode Menu.



The totalizer is running, counting frames and calculating the percentage of error frames, even when the oscilloscope is stopped (not acquiring data).

The ERR (error) counter is a count of Rx and Tx frames with parity errors. The TX FRAMES and RX FRAMES counts include both normal frames and frames with parity errors. When an overflow condition occurs, the counter displays **OVERFLOW**.

The counters can be reset to zero by clicking the **Reset UART Counters** softkey in the UART/RS232 Settings Menu.

## Interpreting UART/RS232 Lister Data

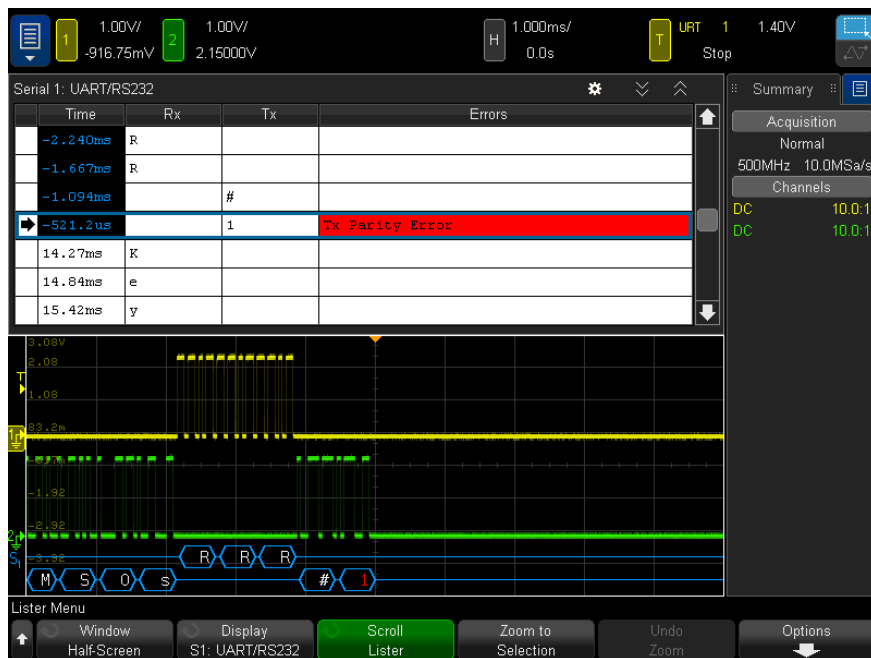



In addition to the standard Time column, the UART/RS232 Lister contains these columns:

- Rx – receive data.
- Tx – transmit data.
- Errors – highlighted in red, Parity Error or Unknown Error.

Aliased data is highlighted in pink. When this happens, decrease the horizontal time/div setting and run again.

## Searching for UART/RS232 Data in the Lister

The oscilloscope's search capability lets you search for (and mark) certain types of UART/RS232 data in the Lister. You can use the sidebar **Navigate** controls to navigate through the marked rows.

- 1 With UART/RS232 selected as the serial decode mode, choose **Main Menu > Analyze > Waveform Search**.
- 2 In the Search Menu, click the **Search** softkey; then, select Serial 1 or Serial 2 on which the UART/RS232 signals are being decoded.
- 3 In the Search Menu, click **Search**; then, select from these options:
  - **Rx Data** – Finds a data byte that you specify. For use when the DUT data words are from 5 to 8 bits in length (no 9th (alert) bit).
  - **Rx 1:Data** – For use when the DUT data words are 9 bits in length including the alert bit (the 9th bit). Finds only when the 9th (alert) bit is 1. The specified data byte applies to the least significant 8 bits (excludes the 9th (alert) bit)
  - **Rx 0:Data** – For use when the DUT data words are 9 bits in length including the alert bit (the 9th bit). Finds only when the 9th (alert) bit is 0. The specified data byte applies to the least significant 8 bits (excludes the 9th (alert) bit).
  - **Rx X:Data** – For use when the DUT data words are 9 bits in length including the alert bit (the 9th bit). Finds a data byte that you specify regardless of the value of the 9th (alert) bit. The specified data byte applies to the least significant 8 bits (excludes the 9th (alert) bit).
  - Similar choices are available for Tx.
  - **Rx or Tx Parity Error** – Finds a parity error based on the parity you have set in the Bus Configuration Menu.
  - **Rx or Tx Any Error** – Finds any error.

For more information on searching data, see "[Searching Lister Data](#)" on page 109.

For more information on using the sidebar **Navigate** controls, see "[Navigating the Time Base](#)" on page 49.



# 28 USB PD Triggering and Serial Decode

Setup for USB PD Signals / 420

USB PD Triggering / 421

USB PD Serial Decode / 423

USB PD (Power Delivery) triggering and serial decode requires the P9240UPDA license.

## Setup for USB PD Signals

To set up the oscilloscope to capture USB PD signals:

- 1 Connect an oscilloscope channel to the signal in the device under test.  
Analog channels can be used.
- 2 Choose **Main Menu > Analyze > Serial Decode**.
- 3 Click the **Serial** softkey, select Serial 1 or Serial 2, and click the softkey again to enable decode.
- 4 Click the **Mode** softkey; then, select **USB PD**.



- 5 Click the **Source** softkey; then, select the channel for the signal.
- 6 Click the **Threshold** softkey; then, enter the signal threshold voltage level.

The threshold voltage level is used in decoding, and it will become the trigger level when the trigger type is set to the selected serial decode (Serial 1 or Serial 2).

## USB PD Triggering

To set up the oscilloscope to capture USB PD signals, see "[Setup for USB PD Signals](#)" on page 420.

When USB PD (Power Delivery) is selected as one of the serial bus decodes, you can trigger on USB PD signals.

To set up a USB PD trigger condition:

- 1 Choose **Main Menu > Trigger > Trigger Menu**.
- 2 In the Trigger Menu, click the **Trigger Type** softkey; then, select the serial decode (Serial 1 or Serial 2) of the USB PD signal.



- 3 Click the **Trigger** softkey and select the USB PD trigger mode:
  - **Preamble Start** – triggers at the start of a preamble, which starts with 0.
  - **EOP** – triggers at the end of packet.
  - **SOP** – triggers on ordered set Sync-1, Sync-1, Sync-1, Sync-2.
  - **SOP'** – triggers on ordered set Sync-1, Sync-1, Sync-3, Sync-3.
  - **SOP''** – triggers on ordered set Sync-1, Sync-3, Sync-1, Sync-3.
  - **SOP' Debug** – triggers on ordered set Sync-1, RST-2, RST-2, Sync-3.
  - **SOP'' Debug** – triggers on ordered set Sync-1, RST-2, Sync-3, Sync-2.
  - **Hard Reset** – triggers on ordered set RST-1, RST-1, RST-1, RST-2.
  - **Cable Reset** – triggers on ordered set RST-1, Sync-1, RST-1, Sync-3.
  - **CRC Error** – triggers when an error is detected on a 32-bit CRC.
  - **Preamble Error** – triggers when an error is detected on a 64-bit sequence of alternating 0 and 1.
  - **Header Content** – triggers on a user-defined 16-bit value.  
In this mode, additional softkeys let you further set up the trigger mode.
- 4 When the **Header Content** trigger mode is selected, click the **Header Type** softkey to select the header type:
  - **Control Message** – triggers on control message types (0 data object). Click the **Message Type** softkey to select the control message.
  - **Data Message** – triggers on data message types (1 or more data objects). Click the **Message Type** softkey to select the data message.
  - **Extended Message** – triggers on extended message types (bit 15 is set). Click the **Message Type** softkey to select the extended data message.

- **Value** – triggers on a user-defined header value. Click the **Base** softkey to specify the number base, and click the **Header** softkey to enter the value.
- 5 Also when the **Header Content** trigger mode is selected, there is a **Qualifier** softkey that can further qualify the trigger:
- **None** – There is no additional qualifier for the trigger.
  - **SOP** – The trigger occurs on Sync-1, Sync-1, Sync-1, Sync-2 ordered sets only.
  - **SOP'** – The trigger occurs on Sync-1, Sync-1, Sync-3, Sync-3 ordered sets only.
  - **SOP"** – The trigger occurs on Sync-1, Sync-3, Sync-1, Sync-3 ordered sets only.

**NOTE**

If the setup does not produce a stable trigger, the USB PD signals may be slow enough that the oscilloscope is AutoTriggering. Click the Run/Stop status in the upper-right corner of the display, and change the trigger mode from **Auto** to **Normal**.

---

**NOTE**

To display USB PD serial decode, see "**USB PD Serial Decode**" on page 423.

---

## USB PD Serial Decode

To set up the oscilloscope to capture USB PD signals, see "[Setup for USB PD Signals](#)" on page 420.

### NOTE

For USB PD triggering setup see "[USB PD Triggering](#)" on page 421.

To set up USB PD serial decode:

- 1 Choose **Main Menu > Analyze > Serial Decode** to display the Serial Decode Menu.



- 2 If the decode line does not appear on the display, choose **Main Menu > Analyze > Serial Decode** again to turn it on.
- 3 If the oscilloscope is stopped, choose **Main Menu > Run/Stop** to acquire and decode data.

### NOTE

If the setup does not produce a stable trigger, the USB PD signals may be slow enough that the oscilloscope is AutoTriggering. Click the Run/Stop status in the upper-right corner of the display, and change the trigger mode from **Auto** to **Normal**.

You can use the horizontal **Zoom** window for easier navigation of the acquired data.

- See Also
- "[Interpreting USB PD Decode](#)" on page 424
  - "[Interpreting USB PD Lister Data](#)" on page 425

## Interpreting USB PD Decode

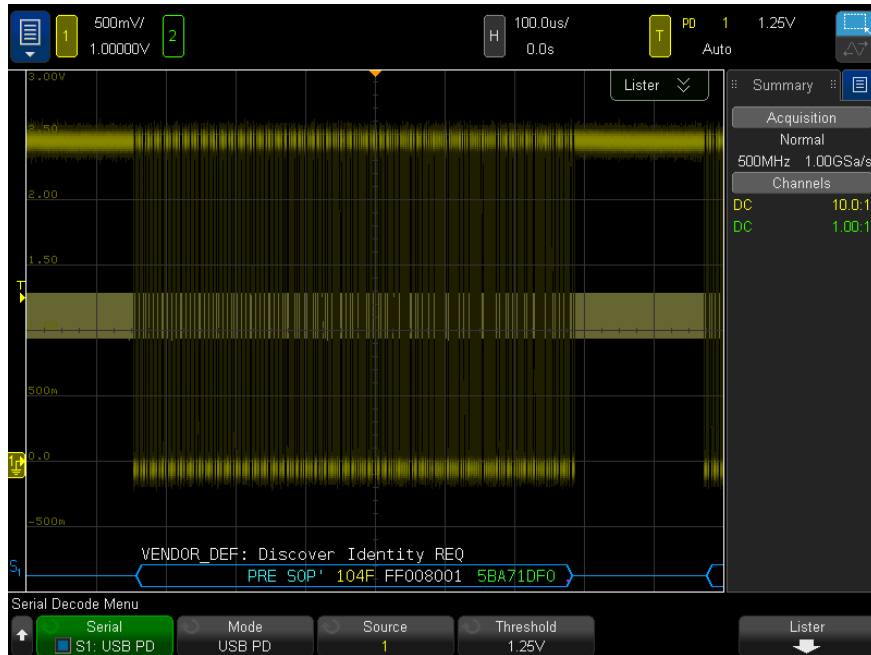

The USB PD decode is displayed as a single bus, with one decode line positioned at the bottom of the waveform area, time-aligned with the associated physical signal. Above the decode line is abbreviated symbolic decode information, shown in white, that describes the header's port power role (bit 8), port data role (bit 5), and message type (bits 4-0).

The decode line shows a blue idle line until the preamble is reached, at which point the start of frame angle bracket (<) is drawn in blue. The end of frame angle bracket (>) is drawn in blue at the end of the EOP, followed by a blue idle line. The fields and hex data within a packet are distinguished by color:

- SOP\* (blue)
- Message Header (yellow)
- Extended Message Header (yellow)
- Data (white)
- CRC (green)
- EOP (blue)

When errors occur, a red error frame is drawn until a valid idle signal is detected. For CRC errors, the decoded text is shown in red. For preamble errors, "PError" is shown in red.



## Interpreting USB PD Lister Data

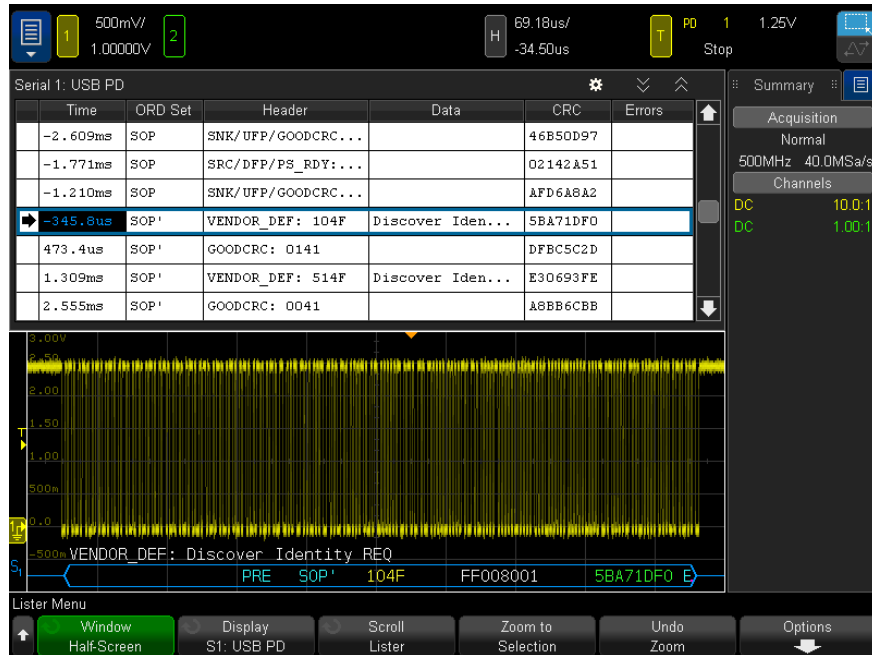

In addition to the standard Time column, the USB PD Lister contains these columns:

- ORD Set – the ordered set type.
- Header – the header type and value.
- Data – the data or extended message.
- CRC – value in Hex.
- Errors – string value that displays the type of error detected.



# Index

## Symbols

- (-) Width measurement, 220
- (+) Width measurement, 220

## Numerics

- 1 M ohm input impedance, 57
- 50 ohm input impedance, 57

## A

- About Oscilloscope, 302
- absolute value math function, 84
- AC channel coupling, 56
- AC RMS - Full Screen measurement, 216
- AC RMS - N Cycles measurement, 215
- accessories, 20
- acquire, 177
- acquisition memory, 130
- acquisition memory, saving, 285
- acquisition mode, 184
- acquisition mode, averaging, 187
- acquisition mode, high resolution, 189
- acquisition mode, normal, 184
- acquisition mode, peak detect, 185
- acquisition mode, preserve during Autoscale, 296
- acquisition modes, 177
- active serial bus, 340, 359, 415
- actual sample rate, 183
- adaptive persistence, 114
- adding measurements, 205
- addition math function, 70
- address with no ack condition, I2C trigger, 355
- adjacent channel power ratio (ACPR) FFT analysis measurement, 228
- AERO license, 307
- aliasing, 180
- aliasing, FFT, 81
- alternating edge trigger, 133
- AM (amplitude modulation), waveform generator output, 275
- Amplitude measurement, 212
- amplitude modulation (AM), waveform generator output, 275
- analog channel, probe attenuation, 61
- analog channel, setup, 51
- analog filters, adjusting, 75

- analysis results, saving, 283
- Analyze Segments, 191, 192, 234
- annotation, adding, 119
- antialiasing, disabling/enabling, 121
- arbitrary generated waveforms, editing, 265
- arbitrary waveform generator output, 263
- arbitrary waveforms, copying from other sources, 270
- arbitrary waveforms, creating new, 266
- arbitrary waveforms, editing existing, 267
- Area - Full Screen measurement, 227
- Area - N Cycles measurement, 227
- ARINC 429 serial decode, 392
- ARINC 429 totalizer, 394
- ARINC 429 trigger, 390
- ARINC 429 words/errors counter, 394
- ARINC 429 decode, signal speed, 388
- ARINC 429 decode, signal type, 388
- ARINC 429 decode, word format, 392
- ASCII file format, 282
- ASCII XY data, 285
- attenuation, probe, 61
- attenuation, probe, external trigger, 176
- attenuators, 63
- Auto Increment, 288
- AUTO license, 307
- Auto Setup, FFT, 78
- Auto trigger mode, 170
- Auto? trigger indicator, 171
- automatic measurements, 203, 208
- AutoProbe interface, 57
- Autoscale, 20
- Autoscale preferences, 295
- Aux Out connector, 299
- Aux Out signal and zone qualified trigger, 168
- Average - Full Screen measurement, 215
- Average - N Cycles measurement, 215
- average measurement trend, 93
- averaged value math function, 89
- averaging acquire mode, 184, 187
- Ax + B math function, 83

## B

- band width, 302
- band width limit, 58
- band width required, oscilloscope, 182
- band width, oscilloscope, 180
- band width, real time sampling, 190
- Bartlett FFT window, 77

- base 10 exponential math function, 86
- Base measurement, 213
- BIN file format, 282
- binary data (.bin), 310
- binary data file examples, 313
- binary data in MATLAB, 310
- binary data, example program for reading, 313
- binary mode cursors, 197
- bit rate measurement, 221
- Blackman Harris FFT window, 77
- blanking, 42
- BMP file format, 282
- Bode plot, frequency response analysis, 259
- brick-wall frequency response, 181
- built-in help, 21
- burst width measurements, 220
- burst, capture signal bursts, 191
- BW Limit? in DVM display, 250

## C

- calibrate probe, 62
- calibration, 301
- CAN decode, source channels, 322
- CAN FD standard, 324
- CAN frame counter, 331
- CAN serial decode, 329
- CAN symbolic data, 325
- CAN totalizer, 331
- CAN trigger, 326
- CANFD license, 307
- capture signal bursts, 191
- cardiac waveform generator output, 264
- Center, FFT, 76
- channel labels, 123
- channel power FFT analysis measurement, 228
- channel, analog, 51
- channel, band width limit, 58
- channel, coupling, 56
- channel, fine adjustment, 59
- channel, invert, 60
- channel, position, 55
- channel, probe units, 61
- channel, skew, 62
- channel, vertical sensitivity, 54
- characteristics, 20
- clear display, 116, 186
- clear display, Quick Clear Display, 304
- clear persistence, 114

Clock Extension Peripheral Interface (CXPI)  
 serial analysis, license, 307  
 common logarithm math function, 85  
 COMP license, 307  
 compensate passive probes, 20  
 connections for frequency response analysis  
 (FRA), 256  
 copyright, 2  
 counter, 252  
 Counter measurement, 219  
 counter, ARINC 429 words/errors, 394  
 counter, CAN frame, 331  
 counter, UART/RS232 frame, 416  
 coupling, channel, 56  
 coupling, trigger, 172  
 crosstalk problems, 75  
 CSV data, 284  
 CSV file format, 282  
 CSV files, minimum and maximum  
 values, 317  
 cursor measurements, 195  
 cursor units, 198  
 cursors, binary, 197  
 cursors, gated measurement window, 232  
 cursors, hex, 197  
 cursors, manual, 197  
 cursors, measure mode, 197  
 cursors, track waveform, 197  
 custom location, time reference, 46  
 CXPI decode, interpreting, 349  
 CXPI decode, signal setup, 344  
 CXPI license, 307  
 CXPI Lister data, 350  
 CXPI serial decode, 348  
 CXPI trigger, 345  
 Czech user interface, 22

## D

d/dt math function, 72  
 DC channel coupling, 56  
 DC offset correction for integrate  
 waveform, 74  
 DC RMS - Full Screen measurement, 215  
 DC RMS - N Cycles measurement, 215  
 DC signals, checking, 171  
 DC waveform generator output, 263  
 DDR burst, random trigger holdoff, 175  
 dead time (re-arm), 192  
 decaying average approximation, 89  
 decibels, FFT vertical units, 77  
 decimating samples, 183  
 decimation, for measurement record, 317  
 decimation, for screen, 317  
 default setup, 20, 292  
 defaults, waveform generator, 279  
 Delay measurement, 208, 221  
 delay time indicator, 46  
 delay, adjusting, 38  
 delayed sweep, 43  
 delete file, 294

depth, AM modulation, 276  
 detection type, FFT (Magnitude), 77  
 deviation, FM modulation, 277  
 differentiate math function, 72  
 digital voltmeter (DVM), 250  
 digits, counter resolution, 253  
 display multiple acquisitions, 178  
 display, clear, 116  
 display, interpreting, 20  
 display, persistence, 114  
 display, signal detail, 112  
 displayed channels Autoscale, 295  
 distortion problems, 75  
 Divide math function, 71  
 Duty cycle measurement, 220  
 duty cycle measurement trend, 93  
 DVM (digital voltmeter), 250

## E

edge speeds, 182  
 edge then edge triggering, 135  
 edge triggering, 133  
 editing measurements, 207  
 EEPROM data read, I2C trigger, 355  
 either edge trigger, 133  
 e-mail setups, images, or data, 289  
 e-mail, Quick Email, 304  
 EMBD license, 307  
 energy of a pulse, 73  
 English user interface and Quick Help, 22  
 envelope math function, 90  
 envelope, max/min, 92  
 environmental characteristics, 20  
 event table, 107  
 expand about, 54, 295  
 expand about center, 295  
 expand about ground, 295  
 exponential fall waveform generator  
 output, 264  
 exponential math function, 86  
 exponential rise waveform generator  
 output, 263  
 exporting waveform, 281  
 EXT TRIG IN as Z-axis input, 42  
 external trigger, 176  
 external trigger, input impedance, 176  
 external trigger, probe attenuation, 176  
 external trigger, probe units, 176

## F

factory default settings, 292  
 Fall time measurement, 221  
 fall time measurement trend, 93  
 falling edges count measurements, 226  
 fast debug Autoscale, 295  
 FFT (Magnitude) detection type, 77  
 FFT aliasing, 81  
 FFT analysis measurements, 228

FFT DC value, 81  
 FFT gating, 77  
 FFT magnitude math function, 75  
 FFT measurement hints, 80  
 FFT peaks, searching, 79  
 FFT phase math function, 75  
 FFT resolution, 80  
 FFT spectral leakage, 83  
 FFT units, 81  
 FFT vertical units, 77  
 FFT window, 76  
 file explorer, 294  
 file format, ASCII, 282  
 file format, BIN, 282  
 file format, BMP, 282  
 file format, CSV, 282  
 file format, PNG, 282  
 file name, new, 288  
 file, save, recall, load, 294  
 filter math function, averaged value, 89  
 filter math function, envelope, 90  
 filter math function, high pass and low  
 pass, 88  
 filter math function, smoothing, 90  
 filters, math, 88  
 fine adjustment, channel, 59  
 fine adjustment, horizontal scale, 45  
 firmware updates, 309  
 Flat top FFT window, 76  
 FM (frequency modulation), waveform  
 generator output, 276  
 folding frequency, 180  
 forcing a trigger, 132  
 FRA (frequency response analysis), 255  
 FRA license, 307  
 frame trigger, I2C, 356  
 frame, LIN symbolic, 338  
 freeze display, 304  
 freeze display, Quick Freeze Display, 304  
 French user interface and Quick Help, 22  
 frequency counter, 253  
 frequency data in CSV files, 318  
 frequency deviation, FM modulation, 277  
 Frequency measurement, 219  
 frequency measurement trend, 93  
 frequency modulation (FM), waveform  
 generator output, 276  
 frequency peaks, searching, 79  
 frequency response analysis (FRA), 255  
 frequency response analysis data,  
 save, 260  
 frequency, Nyquist, 180  
 frequency-shift keying modulation (FSK),  
 waveform generator output, 278  
 FSK (frequency-shift keying modulation),  
 waveform generator output, 278

## G

gated by cursors measurement  
 window, 232

gating, FFT, 77  
 Gaussian frequency response, 181  
 Gaussian pulse waveform generator  
   output, 264  
 Generic video trigger, 158  
 German user interface and Quick Help, 22  
 glitch capture, 185  
 glitch trigger, 137  
 golden waveform test, 235  
 graphical user interface language, 22  
 graticule intensity, 118  
 graticule type, 117  
 grid intensity, 118  
 grid type, 117  
 ground level, 52

## H

Hanning FFT window, 76  
 hardware self test, 302  
 help, built-in, 21  
 hex mode cursors, 197  
 HF Reject, 174  
 high pass filter math function, 88  
 high-frequency noise rejection, 174  
 high-resolution mode, 184, 189  
 holdoff, 175  
 hop frequency, FSK modulation, 278  
 Horizontal controls, 40  
 horizontal position, adjusting, 38  
 horizontal scale fine adjustment, 45  
 Host ID, 306  
 host PC, connecting oscilloscope to, 20

## I

I2C serial decode, 358  
 I2C trigger, 355  
 idle serial bus, 340, 359, 415  
 Impedance softkey, 57  
 increment statistics, 234  
 indeterminate state, 197  
 infinite persistence, 114, 178, 185  
 input impedance, analog channel input, 57  
 installed licenses, 302  
 instantaneous slope of a waveform, 72  
 Integrate math function, 73  
 intensity control, 112  
 interpolate, arbitrary waveform option, 266  
 invert waveform, 60  
 invert waveform generator output, 271  
 Italian user interface and Quick Help, 22

## J

Japanese user interface and Quick Help, 22

## K

keyboard shortcuts for  
   run/stop/single, 178  
 Korean user interface and Quick Help, 22

## L

label list, 127  
 label list, loading from text file, 127  
 labels, 123  
 labels, auto-increment, 126  
 labels, reset library, 128  
 language, user interface, 22  
 length control, 285  
 length softkey, 284  
 level, trigger, 131  
 LF Reject, 172  
 library, labels, 125  
 licenses, 307  
 LIN serial decode, 339  
 LIN symbolic data, 336  
 LIN trigger, 337  
 Lister, 107  
 load file, 294  
 Load from, 288  
 Location, 287  
 Location, File Explorer softkey label, 294  
 logging remote commands, 300  
 logic presets, waveform generator, 273  
 low pass filter math function, 88  
 low-frequency noise rejection, 172

## M

magnify math function, 91  
 Manchester serial decode, 369  
 Manchester trigger, 367  
 Manchester/NRZ serial analysis,  
   license, 307  
 mask files, recall, 290  
 MASK license, 307  
 mask statistics, quick reset, 304  
 mask test, trigger output, 238, 299  
 mask testing, 235  
 mask, Aux Out signal, 299  
 math filters, 88  
 math functions, cascaded, 66  
 math operators, 70  
 math transforms, 72  
 math visualizations, 91  
 math, 1\*2, 71  
 math, 1/2, 71  
 math, addition, 70  
 math, differentiate, 72  
 math, divide, 71  
 math, FFT magnitude/phase, 75  
 math, functions, 65  
 math, integrate, 73

math, multiply, 71  
 math, offset, 68  
 math, scale, 68  
 math, subtract, 70  
 math, units, 68, 69  
 math, using waveform math, 66  
 MATLAB binary data, 310  
 max envelope, 92  
 max hold math function, 92  
 maximum math function, 92  
 Maximum measurement, 211  
 maximum sample rate, 183  
 measure mode cursors, 197  
 measure statistics, quick reset, 304  
 measure, Quick Measure All, 304  
 measurement definitions, 208  
 measurement record, 285  
 measurement statistics, 233  
 measurement thresholds, 230  
 measurement trend math function, 92  
 measurement window, 232  
 measurements, 208  
 measurements, add, 205  
 measurements, automatic, 203  
 measurements, delay, 208  
 measurements, edit, 207  
 measurements, overshoot, 209  
 measurements, phase, 209  
 measurements, preshoot, 209  
 measurements, time, 218  
 measurements, voltage, 211  
 MegaZoom IV, 3  
 memory depth and sample rate, 183  
 memory, segmented, 191  
 message, CAN symbolic, 327  
 MIL-STD-1553 serial decode, 384  
 MIL-STD-1553 trigger, 383  
 min envelope, 92  
 min hold math function, 92  
 minimum math function, 92  
 Minimum measurement, 212  
 missing acknowledge condition, I2C  
   trigger, 355  
 Mode/Coupling key, trigger, 169  
 model number, 302  
 modulation, waveform generator  
   output, 275  
 module installed, 302  
 Multiply math function, 71

## N

N8900A Infiniium Offline oscilloscope  
   analysis software, 282  
 natural logarithm math function, 85  
 navigate files, 294  
 navigating the time base, 49  
 Near Field Communication (NFC) trigger,  
   license, 307  
 Near Field Communication (NFC)  
   triggering, 146

negative pulse width measurement trend, 93  
 new label, 126  
 NFC license, 307  
 NFC triggering, 146  
 noise rejection, 173  
 noise waveform generator output, 263  
 noise, adding to waveform generator output, 274  
 noise, high-frequency, 174  
 noise, low-frequency, 172  
 noisy signals, 169  
 normal acquire mode, 184  
 normal mode, 184  
 Normal trigger mode, 170  
 notices, 2  
 NRZ license, 307  
 NRZ serial decode, 377  
 NRZ trigger, 375  
 Nth edge burst trigger, 149  
 Nth edge burst triggering, 149  
 number of negative pulses measurements, 225  
 number of positive pulses measurements, 225  
 Nyquist frequency, 82  
 Nyquist sampling theory, 180

## O

occupied band width FFT analysis measurement, 228  
 offset (DC) correction for integrate waveform, 74  
 operators, math, 70  
 OR trigger, 142  
 oscilloscope band width, 180  
 oscilloscope band width required, 182  
 oscilloscope rise time, 182  
 oscilloscope sample rate, 182  
 output load expected, waveform generator, 271  
 output settings, waveform generator, 271  
 output, trigger, 299  
 Overshoot measurement, 209, 213

## P

pan and zoom, 37  
 passive probes, compensating, 20  
 pattern trigger, 139  
 peak detect mode, 184, 185  
 peak-peak math function, 92  
 Peak-peak measurement, 211  
 period counter, 253  
 Period measurement, 218  
 period measurement trend, 93  
 persistence, 114  
 persistence, clearing, 114  
 persistence, infinite, 178

Phase measurement, 209, 222  
 phase X cursor units, 198  
 PNG file format, 282  
 points per span, FFT (Magnitude), 78  
 Polish user interface and Quick Help, 22  
 Portuguese user interface and Quick Help, 22  
 position, analog, 55  
 positive pulse width measurement trend, 93  
 post-processing, 204  
 post-trigger information, 38  
 predefined labels, 125  
 Preshoot measurement, 209, 214  
 Press to go, 287  
 Press to go, File Explorer softkey label, 294  
 pre-trigger information, 38  
 probe attenuation, 61  
 probe attenuation, external trigger, 176  
 probe head, 63  
 probe units, 61  
 probe, calibrate, 62  
 probes, 20  
 probes, connecting, 20  
 probes, passive, compensating, 20  
 PTYPE frames, CXPI, 345  
 pulse polarity, 137  
 pulse waveform generator output, 263  
 pulse width trigger, 137

## Q

qualifier, pulse width, 138  
 Quick Action menu item, 304  
 Quick Clear Display, 304  
 Quick Email, 304  
 Quick Freeze Display, 304  
 Quick Help, 21  
 Quick Mask Statistics Reset, 304  
 Quick Measure All, 304  
 Quick Measure Statistics Reset, 304  
 Quick Recall, 304  
 Quick Save, 304  
 Quick Trigger Mode, 304

## R

ramp waveform generator output, 263  
 random noise, 169  
 random trigger holdoff, 175  
 ratio measurement, 217  
 ratio measurement trend, 93  
 ratio X cursor units, 198  
 ratio Y cursor units, 198  
 raw acquisition record, 285  
 realtime sampling and oscilloscope band width, 190  
 realtime sampling option, 190  
 re-arm time, 192  
 recall, 304

recall mask files, 290  
 recall setups, 290  
 recall, Quick Recall, 304  
 Rectangular FFT window, 76  
 Ref I/O connector, 297  
 reference point, waveform, 295  
 reference signal mode, 297  
 reference waveforms, 97  
 remote commands, logging, 300  
 required oscilloscope bandwidth, 182  
 reset label library, 128  
 restart condition, I2C trigger, 355  
 results, frequency response analysis (FRA), 259  
 return instrument for service, 303  
 Rise time measurement, 221  
 rise time measurement trend, 93  
 rise time, oscilloscope, 182  
 rise time, signal, 182  
 rise/fall time triggering, 144  
 rising edge count measurements, 225  
 RMS - AC measurement trend, 93  
 roll mode, 40  
 RS232 trigger, 412  
 runt pulses, 218  
 runt triggering, 150  
 Russian user interface and Quick Help, 22

## S

sample rate, 3  
 sample rate and memory depth, 183  
 sample rate, current rate displayed, 36  
 sample rate, oscilloscope, 181, 182  
 sampling theory, 180  
 sampling, overview, 180  
 save, 304  
 save file, 294  
 save segment, 284  
 save setup files, 283  
 save times, data, 286  
 Save to, 287  
 save, Quick Save, 304  
 saving data, 281  
 SCL, I2C trigger, 354  
 SDA, 354  
 SDA, I2C trigger, 354  
 segmented memory, 191  
 segmented memory, re-arm time, 192  
 segmented memory, saving segments, 284  
 segmented memory, statistical data, 192  
 Selected, File Explorer softkey label, 294  
 self test, hardware, 302  
 SENSOR license, 307  
 SENT data, searching, 408  
 SENT decode, interpreting, 404  
 SENT decode, signal setup, 398  
 SENT fast signals definition, 400  
 SENT Lister data, 407  
 SENT serial decode, 404  
 SENT trigger, 402

serial clock, I2C trigger, 354  
 serial data, 354  
 serial data, I2C trigger, 354  
 serial number, 302  
 service functions, 301  
 setup and hold triggering, 152  
 setup files, saving, 283  
 setup, frequency response analysis (FRA), 257  
 setups, recall, 290  
 shipping precautions, 303  
 shortcuts (keyboard) for  
   run/stop/single, 178  
 Sigma, minimum, 238  
 signal, CAN symbolic, 327  
 signal, inputting, 20  
 signal, LIN symbolic, 338  
 Simplified Chinese user interface and Quick Help, 22  
 sinc waveform generator output, 263  
 sine waveform generator output, 263  
 single-shot acquisitions, 171  
 single-shot events, 178  
 single-shot, waveform generator, 272  
 skew, analog channel, 62  
 slope trigger, 133  
 smoothing math function, 90  
 Snapshot All measurements, 209  
 snapshot all, quick action, 304  
 soft front panel (SFP), opening, 20  
 soft front panel (SFP), using, 21  
 softkey label buttons, 6  
 software updates, 309  
 software version, 302  
 software, installing, 20  
 Span, FFT, 76  
 Spanish user interface and Quick Help, 22  
 specifications, 20  
 spectral leakage, FFT, 83  
 square math function, 84  
 square root, 83  
 square waveform generator output, 263  
 square waves, 181  
 start condition, I2C, 355  
 Start Freq, FFT, 76  
 startup guide information, 20  
 statistics, increment, 234  
 statistics, mask test, 240  
 statistics, measurement, 233  
 statistics, using segmented memory, 192  
 status, User Cal, 302  
 Std Deviation measurement, 216  
 stop condition, I2C, 355  
 Stop Freq, FFT, 76  
 storage locations, navigate, 287  
 subtract math function, 70  
 sweep frequencies, frequency response analysis, 257  
 symbolic data, CAN, 325  
 symbolic data, LIN, 336  
 sync pulse, waveform generator, 272

## T

test, mask, 235  
 Thai user interface and Quick Help, 22  
 theory, sampling, 180  
 threshold, analog channel measurements, 230  
 time measurements, 218  
 time reference indicator, 46  
 time, re-arm, 192  
 timebase, 40  
 times for saving data, 286  
 Top measurement, 212  
 total harmonic distortion (THD) FFT analysis measurement, 229  
 totalize counter, 253  
 totalizer, ARINC 429, 394  
 totalizer, CAN, 331  
 totalizer, UART/rs232, 416  
 tracking cursors, 197  
 Traditional Chinese user interface and Quick Help, 22  
 transforms, math, 72  
 transmit single-shot, waveform generator, 272  
 Trig'd trigger indicator, 171  
 Trig'd? trigger indicator, 171  
 trigger coupling, 172  
 trigger indicator, Auto?, 171  
 trigger indicator, Trig'd, 171  
 trigger indicator, Trig'd?, 171  
 trigger level, 131  
 trigger mode, auto or normal, 170  
 trigger mode, Quick Trigger Mode, 304  
 trigger output, 299  
 trigger output, mask test, 238, 299  
 trigger qualified event signal, counting, 252  
 trigger signal, raw, 299  
 trigger type, ARINC 429, 390  
 trigger type, CAN, 326  
 trigger type, CXPI, 345  
 trigger type, edge, 133  
 trigger type, edge then edge, 135  
 trigger type, glitch, 137  
 trigger type, I2C, 355  
 trigger type, LIN, 337  
 trigger type, Manchester, 367  
 trigger type, MIL-STD-1553, 383  
 trigger type, NFC, 146  
 trigger type, NRZ, 375  
 trigger type, Nth edge burst, 149  
 trigger type, OR, 142  
 trigger type, pattern, 139  
 trigger type, pulse width, 137  
 trigger type, rise/fall time, 144  
 trigger type, RS232, 412  
 trigger type, runt, 150  
 trigger type, SENT, 402  
 trigger type, setup and hold, 152  
 trigger type, slope, 133  
 trigger type, UART, 412

trigger type, USB PD, 421  
 trigger type, video, 154  
 trigger types, 129  
 trigger, definition, 130  
 trigger, external, 176  
 trigger, forcing a, 132  
 trigger, general information, 130  
 trigger, holdoff, 175  
 trigger, mode/coupling, 169  
 trigger, source, 133  
 trigger, zone qualified, 167  
 triggers, Aux Out signal, 299  
 Turkish user interface, 22

## U

UART totalizer, 416  
 UART trigger, 412  
 UART/RS232 frame counter, 416  
 UART/RS232 license, 307  
 UART/RS232 serial decode, 414  
 under-sampled signals, 180  
 units, cursor, 198  
 units, external trigger probe, 176  
 units, math, 68, 69  
 units, probe, 61  
 updating software and firmware, 309  
 upgrade options, 307  
 USB 3.0 port required, 20  
 USB PD decode, interpreting, 424  
 USB PD decode, signal setup, 420  
 USB PD Lister data, 425  
 USB PD serial analysis, license, 307  
 USB PD serial decode, 423  
 USB PD trigger, 421  
 USBPD license, 307  
 user cal, 301  
 user calibration, 301  
 user interface language, 22  
 utilities, 293

## V

V RMS, FFT vertical units, 77  
 variable persistence, 114  
 vertical expansion, 54  
 vertical offset, 55  
 vertical position, 55  
 vertical sensitivity, 54  
 Vertical Units, FFT, 77  
 VID license, 308  
 video trigger, 154  
 video trigger, custom Generic, 158  
 visualizations, math, 91  
 voltage measurements, 211

## W

warranty, 2, 303

## Index

- waveform generator, [261](#)
- waveform generator amplitude, frequency response analysis, [258](#)
- waveform generator defaults, restoring, [279](#)
- waveform generator expected output load, [271](#)
- waveform generator logic presets, [273](#)
- waveform generator output settings, [271](#)
- waveform generator sync pulse, [272](#)
- waveform generator sync pulse, Aux Out signal, [299](#)
- waveform generator, arbitrary waveforms, [265](#)
- waveform generator, invert output, [271](#)
- waveform generator, output single-shot, [272](#)
- waveform generator, waveform type, [262](#)
- waveform type, waveform generator, [262](#)
- waveform, cursor tracking, [197](#)
- waveform, intensity, [112](#)
- waveform, reference point, [295](#)
- waveform, saving/exporting, [281](#)
- WAVEGEN license, [308](#)
- white noise, adding to waveform generator output, [274](#)
- Width - measurement, [220](#)
- Width + measurement, [220](#)
- Window, FFT, [76](#)

## X

- X at Max Y measurement, [224](#)
- X at Max Y on FFT, [209](#)
- X at Min Y measurement, [223](#)
- X at Min Y on FFT, [209](#)
- XY mode, [40](#)

## Z

- Z-axis blanking, [42](#)
- zero phase reference, FFT (Phase), [78](#)
- zone qualified trigger, [167](#)
- zoom and pan, [37](#)
- zoom display measurement window, [232](#)