

# M & G PRESSURE TESTER

INSTRUCTION BULLETIN  
FOR  
HYDRA—LITE™ DEADWEIGHT INSTRUMENTS

MODEL HL DEADWEIGHT TESTERS  
MODEL HLG DEADWEIGHT GAUGES

Visit [TRANSCAT.com](https://www.transcat.com) >

[sales@transcat.com](mailto:sales@transcat.com) | 800.828.1470

For Repair and Recalibration  
Return to

**AMETEK**

TEST AND CALIBRATION INSTRUMENTS DIVISION  
8600 SOMERSET DR., LARGO FL 33773



# **METEK**

TEST AND CALIBRATION INSTRUMENTS DIVISION

Testing Equipment

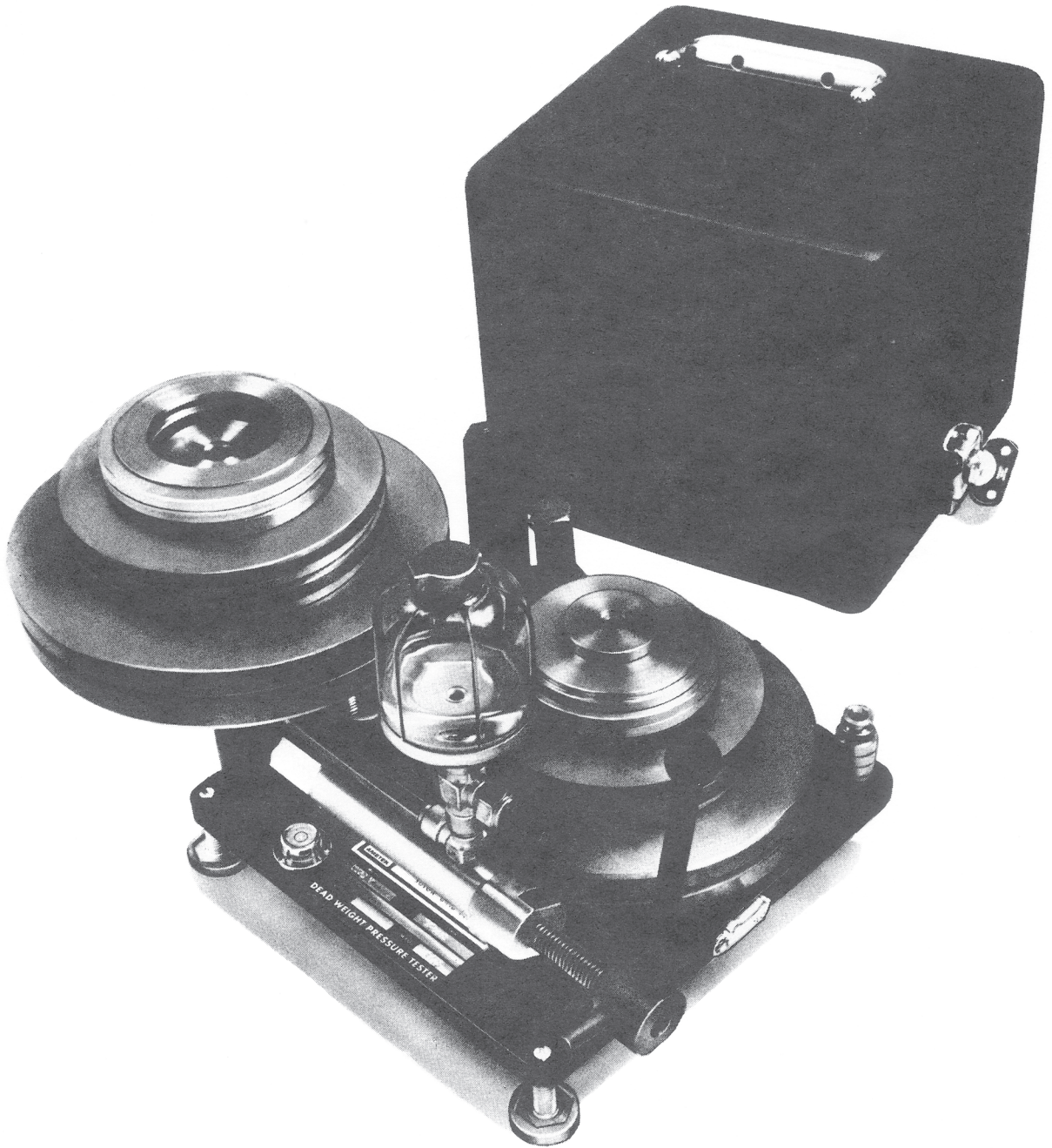

## **INSTRUCTION BULLETIN**

**HYDRA-LITE DEADWEIGHT TESTERS  
AND DEADWEIGHT GAUGES**

**MODELS HL & HLG**



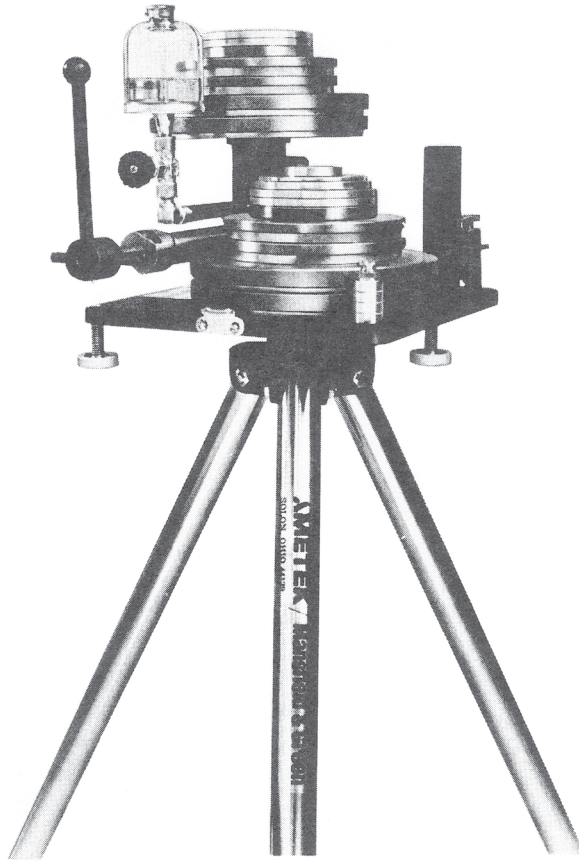

VIEW SHOWING HYDRA-LITE DEADWEIGHT TESTER MOUNTED ON OPTIONAL TRIPOD.

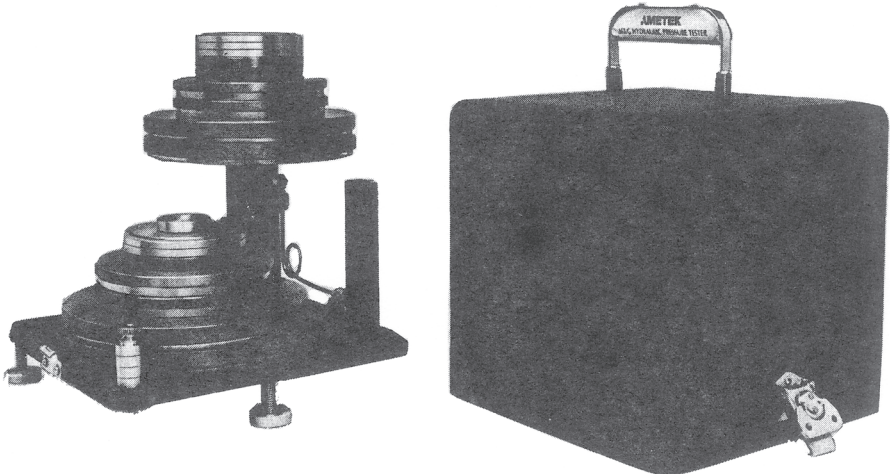

HYDRA-LITE DEADWEIGHT GAUGE.



## **TABLE OF CONTENTS**

<b>SECTION 1 — MODEL DESCRIPTION</b>	<b>Page 6</b>
<b>SECTION 2 — ASSEMBLY AND SETUP INSTRUCTIONS</b>	<b>Page 9</b>
<b>SECTION 3 — OPERATING INSTRUCTIONS</b>	<b>Page 10</b>
<b>SECTION 4 — SERVICE INSTRUCTIONS</b>	<b>Page 11</b>
<b>SECTION 5 — CORRECTION FACTORS</b>	<b>Page 12</b>
<b>SECTION 6 — RECERTIFICATION PROCEDURES</b>	<b>Page 12</b>
<b>SECTION 7 — PARTS LIST</b>	<b>Page 14</b>

## **ILLUSTRATIONS**

<b>FIGURE 1 — SIDE VIEW, HYDRA-LITE TESTER</b>	<b>Page 19</b>
<b>FIGURE 2 — PLAN VIEW, HYDRA-LITE TESTER</b>	<b>Page 20</b>
<b>FIGURE 3 — SIDE VIEW, HYDRA-LITE GAUGE</b>	<b>Page 21</b>
<b>FIGURE 4 — PLAN VIEW, HYDRA-LIT GAUGE</b>	<b>Page 22</b>
<b>FIGURE 5 — PUMP ASSEMBLY</b>	<b>Page 23</b>

**OPERATIONAL INSTRUCTIONS**  
**FOR USE WITH**  
**HYDRA-LITE™ DEADWEIGHT PRESSURE INSTRUMENTS**

**SECTION 1 – MODEL DESCRIPTION**

The HYDRA-LITE hydraulic dead weight instruments are light weight, compact, portable and highly accurate. HYDRA-LITE instruments operate on the dead weight principle using only fundamental units of force and area. Fluid pressure equals the weight force divided by the piston area.

HL Models are complete dead weight testers including an oil reservoir, pump, deadweight column, pointer puller and set, instrument post, and 1/2" NPT adapter. Model HLG deadweight gauges include the deadweight column, instrument post and 1/2" NPT adapter. An optional conversion kit, T-535, is available to convert a deadweight gauge to a deadweight tester. Weights and piston-cylinder assemblies are supplied with each HYDRA-LITE instrument as tabulated in the charts below.

MODEL	RANGE	INCREMENTS	PISTON AREA SQ. IN.	WEIGHT SET NO.
2	10–200 PSI	.1 PSI	.05	1
4	10–400 PSI	.1 PSI	.05	2
6	10–600 PSI	.1 PSI	.05	3
10	50–1000 PSI	.5 PSI	.01	1
20	50–2000 PSI	.5 PSI	.01	2
30	50–3000 PSI	.5 PSI	.01	3
12	10–200 PSI 50–1000 PSI	.1 PSI .5 PSI	.05 .01	1
24	10–400 PSI 50–2000 PSI	.1 PSI .5 PSI	.05 .01	2
36	10–600 PSI 50–3000 PSI	.1 PSI .5 PSI	.05 .01	3



MODEL	RANGE	INCREMENTS	PISTON AREA SQ. IN.	WEIGHT SET NO.
15M	1-15 KG/CM <sup>2</sup>	.005 KG/CM <sup>2</sup>	.05	1M
30M	1-30 KG/CM <sup>2</sup>	.005 KG/CM <sup>2</sup>	.05	2M
45M	1-45 KG/CM <sup>2</sup>	.005 KG/CM <sup>2</sup>	.05	3M
75M	5-75 KG/CM <sup>2</sup>	.025 KG/CM <sup>2</sup>	.01	1M
150M	5-150 KG/CM <sup>2</sup>	.025 KG/CM <sup>2</sup>	.01	2M
225M	5-225 KG/CM <sup>2</sup>	.025 KG/CM <sup>2</sup>	.01	3M
90M	1-15 KG/CM <sup>2</sup> 5-75 KG/CM <sup>2</sup>	.005 KG/CM <sup>2</sup> .025 KG/CM <sup>2</sup>	.05 .01	1M
180M	1-30 KG/CM <sup>2</sup> 5-150 KG/CM <sup>2</sup>	.005 KG/CM <sup>2</sup> .025 KG/CM <sup>2</sup>	.05 .01	2M
270M	1-45 KG/CM <sup>2</sup> 5-225 KG/CM <sup>2</sup>	.005 KG/CM <sup>2</sup> .025 KG/CM <sup>2</sup>	.05 .01	3M

MODEL	RANGE	INCREMENTS	PISTON AREA SQ. IN.	WEIGHT SET NO.
1500N	100-1500 KPA	.5 KPA	.05	1N
3000N	100-3000 KPA	.5 KPA	.05	2N
4500N	100-4500 KPA	.5 KPA	.05	3N
7500N	500-7500 KPA	2.5 KPA	.01	1N
15,000N	500-15,000 KPA	2.5 KPA	.01	2N
22,500N	500-22,500 KPA	2.5 KPA	.01	3N
9000N	100-1500 KPA 500-7500 KPA	.5 KPA 2.5 KPA	.05 .01	1N
18,000N	100-3000 KPA 500-15,000 KPA	.5 KPA 2.5 KPA	.05 .01	2N
27,000N	100-4500 KPA 500-22,500 KPA	.5 KPA 2.5 KPA	.05 .01	3N

WEIGHTS FURNISHED WITH HYDRA — LITE TESTERS & GAUGES

WEIGHT SET NO.	QUANTITY PER SET							
	WG-234	WG-230	WG-233	WG-231	WG-232	WG-23	WG-25	WG-229
1	1	4	1	1	4	3	4	0
2	1	4	1	1	4	3	4	2
3	1	4	1	1	4	3	4	4
	WG-256	WG-257	WG-258	WG-259	WG-260	WG-261	WG-186	WG-255
1M	1	5	1	1	4	4	2	1
2M	1	5	1	1	4	4	5	1
3M	1	5	1	1	4	4	8	1
	WG-263	WG-264	WG-265	WG-266	WG-267	WG-268	WG-269	WG-262
1N	1	5	1	1	4	4	2	1
2N	1	5	1	1	4	4	5	1
3N	1	5	1	1	4	4	8	1

PRESSURE GENERATED BY WEIGHTS

Piston Area	PRESSURE – PSI								
	1/20	.1	.2	1	2	2	10	40	100
1/100	.5	1	5	10	10	50	200	500	25
Part No.	WG-234	WG-230	WG-233	WG-231	WG-232	WG-23	WG-25	WG-229	w/c Assy

Piston Area	PRESSURE – KG/CM <sup>2</sup>								
	1/20	.005	.01	.05	.1	.2	1	5	1
1/100	.025	.05	.25	.5	1	5	25	5	
Part No.	WG-256	WG-257	WG-258	WG-259	WG-260	WG-261	WG-186	w/c Assy plus WG-255	

Piston Area	PRESSURE – KPA, KN/M <sup>2</sup>								
	1/20	.5	1	5	10	20	100	500	100
1/100	2.5	5	25	50	100	500	2500	500	
Part No.	WG-263	WG-264	WG-265	WG-266	WG-267	WG-268	WG-269	w/c Assy plus WG-262	

W/C — Weight Carrier

Weights are made from a hard, non magnetic zinc alloy or wrought aluminum.

HYDRA—LITE deadweight testers and gauges are calibrated for International Standard Gravity 980.665 cm/sec<sup>2</sup> to an accuracy of plus or minus 0.1% of indicated pressure traceable to the National Institute of Standards and Technology (NIST).

**CAUTION**

HYDRA-LITE test fluid is TCI Type AAA tester oil. The instruments being calibrated or pressure medium being measured must be either gas or liquids compatible with mineral oil.

ACCESSORY – the HYDRA–LITE may be tripod mounted for portable operation. An accessory tripod is available.

## SECTION 2 – ASSEMBLY AND SETUP INSTRUCTIONS

- A. Remove the unit from shipping carton by taking the handle and lifting it out of the carton.
- B. Place unit on a firm surface.
- C. Remove the lid and store it in a convenient place to prevent damage.
- D. Remove the shipping screw and washer from the weight stack and set aside. Temporarily remove the weights from the tester.
- E. Install the adjustable leveling legs into the base making sure that they do not protrude above the top of the base.
- F. Level the unit by turning the adjustable leveling legs with the aid of the bull’s-eye level located next to the column.
- G. Replace the stack of weights removed from the unit. Add the remaining weights packed in the bottom of the shipping carton. The draw bar with the knurled nut attached to it may now be inserted thru the middle of the weight stack and secured by threading into the base. This draw bar should be used to maintain the weight stack in its proper position whenever the unit is being transported.
- H. Remove the tape from the weight carrying tube (T-522) securing it to the column.

## SECTION 3 – OPERATING INSTRUCTIONS

### 3.1 Dual Range Models HL and HLG

- A. Select the correct piston and cylinder to suit the required pressure range. Use the table in Section 1 or the decal attached to the tester base as a guide.
- B. To remove a piston and cylinder assembly, turn retainer nut (T-570) counter clockwise until loose and lift off the nut and tube carrier (T-571). Remove the cylinder with a 1 inch open end wrench.
- C. To install a piston and cylinder assembly on the column, place the 10-90014 O ring in the column recess, and thread the cylinder into the column and tighten. Do not overtighten, as it may damage the cylinder. Replace the retainer nut and tube carrier over the cylinder and thread on finger tight.

### 3.2 Model HL, Dead Weight Tester

- A. Open both tester valves. (K-1575)
- B. Fill the oil reservoir approximately 3/4 full with TCI AAA hydraulic tester oil from the 1/2 pint can supplied with the unit.
- C. Close the output valve and withdraw the pump screw by turning the crank counterclockwise until the pump is filled with oil.
- D. Open the output valve and close the reservoir valve.
- E. Slowly turn the pump screw clockwise until no air bubbles can be seen coming through the oil as it rises in the instrument post (T-507). Adjust the oil level to the top of the instrument post.
- F. Connect the instrument to the instrument post.

**CAUTION**

**THE PRESSURE RATING OF THE TUBING AND FITTINGS USED TO CONNECT THE PUMP TO THE TEST DEVICE MUST EXCEED THE PRESSURE CAPABILITY OF THE PUMP (3,000 PSI).**

- G. Place the correct number of weights to give the desired pressure on the weight carrying tube. Screw the pump in until the piston floats and rotate the weight stack 10 to 30 RPM to reduce friction. The ideal float position is between the middle two horizontal reference marks on the column (T-512) as indicated by the bottom of the weight carrying tube (T-522).

**CAUTION**

**DO NOT OPEN RESERVOIR VALVE WHEN UNIT IS UNDER PRESSURE  
PRESSURIZING THE RESERVOIR WILL BLOW THE OIL OUT OF THE TESTER.**

**NOTE:** The screw pump handle will become increasingly difficult to turn as higher pressures are generated. An extension arm, T-504, has been supplied for use with the pump handle and is located next to the oil reservoir threaded into the base. The extension arm threads into the pump handle and can be operated in much the same fashion as an indexing ratchet wrench. By pulling on the spring-loaded handle outward and away from the tester, the handle will disengage from the threaded pump rod. The handle may then be rotated independently of the threaded pump rod and after indexing 90 degrees be allowed to snap back for normal operation.

### 3.3 Set-up and use of the Tester as a Gauge (HL)

- A. Perform steps A through E in Section 3.1
- B. Close the output valve and connect the pressure source at the instrument post.
- C. Place enough weights on the weight carrying tube to equal the estimated pressure.
- D. Slowly open the output valve, rotate the weight stack, and add or remove weights until the piston is in the float position.

### 3.4 Set-up and use of the Gauge (HLG)

- A. Remove the piston and cylinder assembly from the column.
- B. **Fill the column with TCI AAA hydraulic tester oil from the ½ pint can supplied with the unit.**
- C. Continue to fill slowly until no air bubbles can be seen coming thru the oil as it rises in the instrument post.
- D. Replace the piston and cylinder assembly making sure that the face seal “O” ring is in place and properly positioned.
- E. Continue to fill through the instrument post until the oil level is to the top.

NOTE: The above steps are intended to prime the system, purging it of air. In order to prevent loss of prime, maintain the oil level near the top of the gauge post. In the event that prime is lost the above steps should be repeated.

- F. Place enough weights on the weight carrying tube to balance the estimated pressure.
- G. Connect the pressure source to be measured to the instrument post and slowly apply pressure to the HYDRA—LITE gauge. Rotate the weight stack and add or subtract weights until the piston reaches an equilibrium float condition.

## SECTION 4 – SERVICE INSTRUCTIONS

### 4.1 Cleaning Piston and Cylinder

If a piston and cylinder is shipped installed in a tester, no cleaning is required prior to use. Each piston and cylinder shipped separately should be cleaned prior to use.

Periodic recleaning of the piston and cylinder is necessary. A lack of sensitivity to small pressure changes is an indication that the piston and cylinder assembly requires recleaning.

Suggested cleaning procedure is as follows:

- A. Carefully wipe off any visible dirt or foreign matter from the protruding part of the piston and slowly withdraw the piston from the cylinder. Do not use force, but be sure all dirt is removed so that piston will slip out easily.
- B. Cylinder bore should be wiped with a small wood handled wiper such as a “Q Tip” to remove all evidence of dirt. Wipe the piston dry and clean with a lint free wiper such as “Kim Wipe”.
- C. Rinse piston and cylinder in residual free solvent.
- D. Wipe cylinder bore and piston again to remove any dirt.
- E. Pick up piston by piston cap and dip it in clean fluid to be used in tester, then carefully insert piston in the cylinder. If any feeling of roughness or what might be grit in the annulus area is suspected, disassemble and repeat cleaning procedure.



F. At the same time, the dead weight column, output post and tubing should be drained and flushed with a residual free solvent, then cleaned, dried and refilled using clean fluid.

G. The piston-cylinder assembly then can be installed carefully in the mounting column.

REMEMBER — Do not touch piston with fingers or other soiled or contaminating surfaces after cleaning.

- Extremely minute particles can cause trouble in a closely fitted assembly such as this. It is not possible to over emphasize the value of cleanliness.

## SECTION 5 – CORRECTION FACTORS

To obtain the maximum accuracy of which this tester is capable, it is essential that certain corrections be made.

### 5.1 Correction for User's Gravity

All HYDRA—LITE testers are calibrated for accuracy of output pressure at International Standard Gravity (980.665 cm/sec<sup>2</sup>). When used in a location having a local gravity other than 980.665 cm/sec<sup>2</sup>, the actual tester output pressure must be calculated as follows: divide the local gravity by 980.665 and multiply the quotient by the nominal pressure increment. EXAMPLE: Find the true pressure output at 1000 PSI at a location having a local gravity of 980.000 cm/sec<sup>2</sup>.

$$\frac{980.000}{980.665} = .9993219$$

$$1000 \times .9993219 = 999.3219 \text{ PSI}$$

### 5.2 Fluid Head

When hydraulically pressurized, a correction is required only when the gauge height or the reference plane of the unit being calibrated is either higher or lower than that of the HYDRA—LITE tester. This correction is made at a rate of 0.031 PSI per inch of head (head being the height between the bottom of the HYDRA—LITE piston and the gauge or reference plane of the instrument being calibrated). The HYDRA—LITE reference plane is 3/4" below the top edge of the instrument post when the piston is in mid stroke.

## SECTION 6 – RECERTIFICATION PROCEDURES

### 6.1 Introduction

The piston & cylinder, given proper care, will give satisfactory service for many years. This unit, however, can be damaged or worn in such a manner that inaccurate pressure readings are received. A slight oil leakage between the piston & cylinder is normal and desirable to assure proper lubrication. An unusual increase in the degree of leakage may be an indication that the cylinder is worn. Excessive misalignment or wobbling of the weight stack during operation may indicate that the piston is damaged. If either condition is suspected, the piston & cylinder, should be returned to TCI Division for examination and recertification.

### 6.2 Frequency of Recertification

The recommended frequency of recertification is a direct function of the use to which the tester is subjected. As a general rule, TCI hydraulic testers should be tested and recertified every 12 months. Testers used frequently, or with dirty fluids, should be tested and certified at more frequent intervals. Master units, used infrequently may be tested and certified less frequently.

### 6.3 Material Necessary for Recertification

The following parts should be returned to TCI for testing and certification.

- a. Piston / cylinder assembly (T-572 and/or T-573)
- b. Tube Carrier (T-271) and Tube (T-522)
- c. All weights that have the same serial number as the tester

NOTE — It is not necessary to send in the pump if it is functioning satisfactorily. All pumps sent in will be refurbished at a nominal charge.

— In order to reduce process time and your overall cost, please do not send in any customized fittings, hoses, tools or small miscellaneous parts.

**6.4 Packaging Instruction**

All parts returned to TCI must be securely packaged to preclude damage in shipping. Pistons and cylinders should be placed within the protective container (T-539) or other secure package. NOTE: Remove leveling legs (99-90016) before shipping to prevent damage to weights during shipping.

**6.5 Certification options for new and used testers**

Before ordering a new tester or sending an old tester material back to TCI, specify one of the following certification options and any additional requirements on your purchase order. Contact the distributor if you need any assistance.

**AMETEK TCI DIVISION DEADWEIGHT TESTER CERTIFICATION OPTIONS**

Option	Description
A	STANDARD CERTIFICATION OF ACCURACY TRACEABLE TO NIST STANDARDS (Item is repaired and calibrated, but no data is provided)
— Options with Additional Cost —	
B	“WITH DATA” - OPTION A PLUS DATA (Item is repaired and calibrated, data is provided)
C	“ISO 9000 REQUIREMENTS” OPTION FOR NEW TESTERS (Option B plus NIST and Working Standards calibration and due dates, accuracy of standards, accuracy ratio statement, copy of ISO certification, and a Certificate of conformance)
D	“AS RECEIVED / AS LEFT” DATA PLUS OPTION A (Item is cleaned and tested with no adjustments or repairs. Then the item is adjusted or repaired and recalibrated if necessary)
E	“AS RECEIVED / AS LEFT” PER MGP-213 PLUS OPTION A (Same as option C, with additional information pertaining to who and what was used to do the calibration, calibration procedures, and if the device was in tolerance as received and what was done to correct the out-of-tolerance condition)
F	“ISO 9000 REQUIREMENTS” OPTION FOR USED TESTERS (Option D plus NIST and Working Standards calibration and due dates, accuracy of standards, accuracy ratio statement copy of ISO certification, and a Certificate of Conformance)

## HL PARTS LIST

<u>Part Number</u>	<u>Description</u>	<u>No. Req'd.</u>
HL	Hydraulic Pressure Tester	
T-505	Plate – Base	1
1GT-99	Assembly – Gauge Pointer Puller and Set	1
01-90044	Scr – #8 – 32 x 3/4 Soc. Hd. Cap	1
07-90004	Lockwasher – #8 Split	1
04-90022	Nut – #8 – 32 Hex	1
T-518	Rod – Small Weight Guide	1
07-90000	Lockwasher – 1/4 Split	5
04-90018	Nut – 1/4 – 20 Hex	4
99-90010	T Nut – 1/4 – 20 Brass	1
T-502	Guide – Weight	1
01-90000	Scr – 1/4 – 20 x 3/4 Soc. Hd. Cap	4
11-90009	Adapter – 1/4 to 1/2 NPT	1
K-1246	Level	1
K-1182	Spring – Level Positioning	1
03-90020	Scr – #2 – 56 x 5/16 Fil. Hd.	3
T-504	Arm – Lever	1
99-90016	Leg – Leveling	3
T-512	Column – DWT	1
07-90001	Lockwasher – #10 Split	2
01-90027	Scr – #10 – 32 x 1" Soc. Hd. Cap	2
11-90007	Long Hex Nipple – 1/8 NPT 4"	1
11-90006	Street Elbow - 1/8 NPT	1
13-90014	Valve – 1/8 F x 1/8 F	2
99-90014	Reservoir – Oil	1
11-90008	Elbow – 1/8 NPT Male	1
12-90039	Elbow – 1/8 NPT x 1/8 OD Tube	1
T-515	Tube – Gauge Post	1
12-90040	Straight Connector – 1/8 NPT x 1/8 Tube	1
T-507	Post – Instrument	1
T-516	Pump Assembly	1
T-573	Assembly – HL 1/100 Area Piston & Cylinder	1
T-572	Assembly – HL 1/20 Area Piston & Cylinder	1
T-539	Container, Protective	1
T-522	Tube – Weight Carrying	1
T-509	Enclosure – DWT	1
T-501	Bracket – Handle	1
T-508	Handle – Carrying Case	1
99-90013	Catch – Compression Spring	2
03-90027	Scr – #5 – 40 x 1/4 Rd Hd	8
T-570	Retainer Nut – Piston and Tube Carrier	1
T-571	Tube Carrier	1
07-90005	Lockwasher – #5 External Tooth	8
04-90028	Nut – #5 – 40 Hex	4
MG AAA/ 1/2 PT	1/2 Pint Can of M & G AAA Tester Oil	1



## HLG PARTS LIST

<u>Part No.</u>	<u>Description</u>	<u>No. Reqd.</u>
HLG	Hydraulic Pressure Guage	
T-505	Plate – Base	1
T-518	Rod – Small Weight Guide	1
07-90000	Lockwasher – 1/4 Split	5
04-90018	Nut – 1/4 – 20 Hex	4
99-90010	T Nut – 1/4 – 20 Brass	1
T-502	Guide – Weight	1
01-90000	Scr – 1/4 – 20 x 3/4 Soc. Hd. Cap	4
11-90009	Adapter – 1/4 to 1/2 NPT	1
K-1246	Level	1
K-1182	Spring – Level Positioning	1
03-90020	Scr – #2 – 56 x 5/16 Fil. Hd.	3
99-90016	Leg – Leveling	3
T-512	Column – DWT	1
07-90001	Lockwasher – #10 – Split	2
01-90027	Scr – #10 – 32 x 1" Soc. Hd. Cap	2
T-117	Plug	1
11-90010	Pipe Plug – 1/8 NPT Hex Socket	1
12-90039	Elbow – 1/8 NPT x 1/8 O.D. Tube	1
T-517	Tube – Gauge Post	1
12-90040	Straight Connector – 1/8 NPT x 1/8 Tube	1
T-507	Post – Instrument	1
T-573	Assembly – HL 1/100 Area Piston & Cylinder	1
T-572	Assembly – HL 1/20 Area Piston & Cylinder	1
T-539	Container, Protective	1
T-522	Tube – Weight Carrying	1
T-509	Enclosure – DWT	1
T-501	Bracket – Handle	1
T-508	Handle – Carrying Case	1
99-90013	Catch – Compression Spring	2
03-90027	Scr – #5 – 40 x 1/4 Rd. Hd.	8
07-90005	Lockwasher – #5 External Tooth	8
04-90028	Nut – #5 – 40 Hex	4
MG AAA/ 1/2 PT	1/2 Pint Can of M & G AAA tester oil	1
T-570	Retainer Nut - Piston & Tube Carrier	1
T-571	Tube Carrier	1

## T-516 PUMP ASSEMBLY

<u>Part No.</u>	<u>Description</u>	<u>No. Req'd.</u>
T-516	Pump Assembly	
T-523	Piston – Screw Pump	1
09-90004	Ball – 3/8 Dia. Grade 200 Chrome Alloy Steel	1
T-513	Drive Screw – Pump	1
T-524	Washer – Screw Pump Piston	1
21-90001	Snap Ring	1
T-514	Nut – Screw Pump	1
T-511	Body – Screw Pump	1
T-506	Body – Handle	1
99-90011	Spring – Compression	1
99-90012	Screw – Shoulder	1
T-503	Arm – Handle	2
99-90009	Glide Ring	1
10-90090	O-Ring	1

T-535 CONVERSION KIT

HLG TO HL

<u>Part No.</u>	<u>Description</u>	<u>No. Reqd.</u>
T-535	Conversion Kit – HLG to HL	
T-504	Arm – Lever	1
T-515	Tube – Guage Post	1
T-516	Pump Assembly	1
1GT-99	Assembly – Pointer Puller & Setter	1
01-90044	Scr – #8 – 32 x 3/4" Soc. Hd. Cap.	1
04-90022	#8 – 32 Nut	1
07-90004	#8 Split Lockwasher	1
10-90013	"O" ring – Dash #016	1
11-90006	1/8 NPT Street Elbow	1
11-90007	Long Hex Nipple – 1/8 NPT x 4" Long	1
11-90008	Elbow – 1/8 NPT – Male	1
12-90039	Elbow – 1/8 NPT x 1/8 OD Tube	1
12-90040	Straight Connector – 1/8 NPT x 1/8 OD Tube	1
13-90014	1/8 Female x 1/8 Female valve	2
99-90014	Reservoir – Oil	1

T-536 SEAL KIT  
FOR HL & HLG

<u>Part No.</u>	<u>Description</u>	<u>No. Reqd.</u>
T-536	Seal Kit — HL & HLG	
10-90013	“O” Ring .614 IX x .070 W	1
10-90014	“O” Ring .644 ID x .087 W Dash #016	1
10-90090	“O” Ring for .750 glide ring Dash #2-112	1
99-90009	Glide ring — Teflon	1

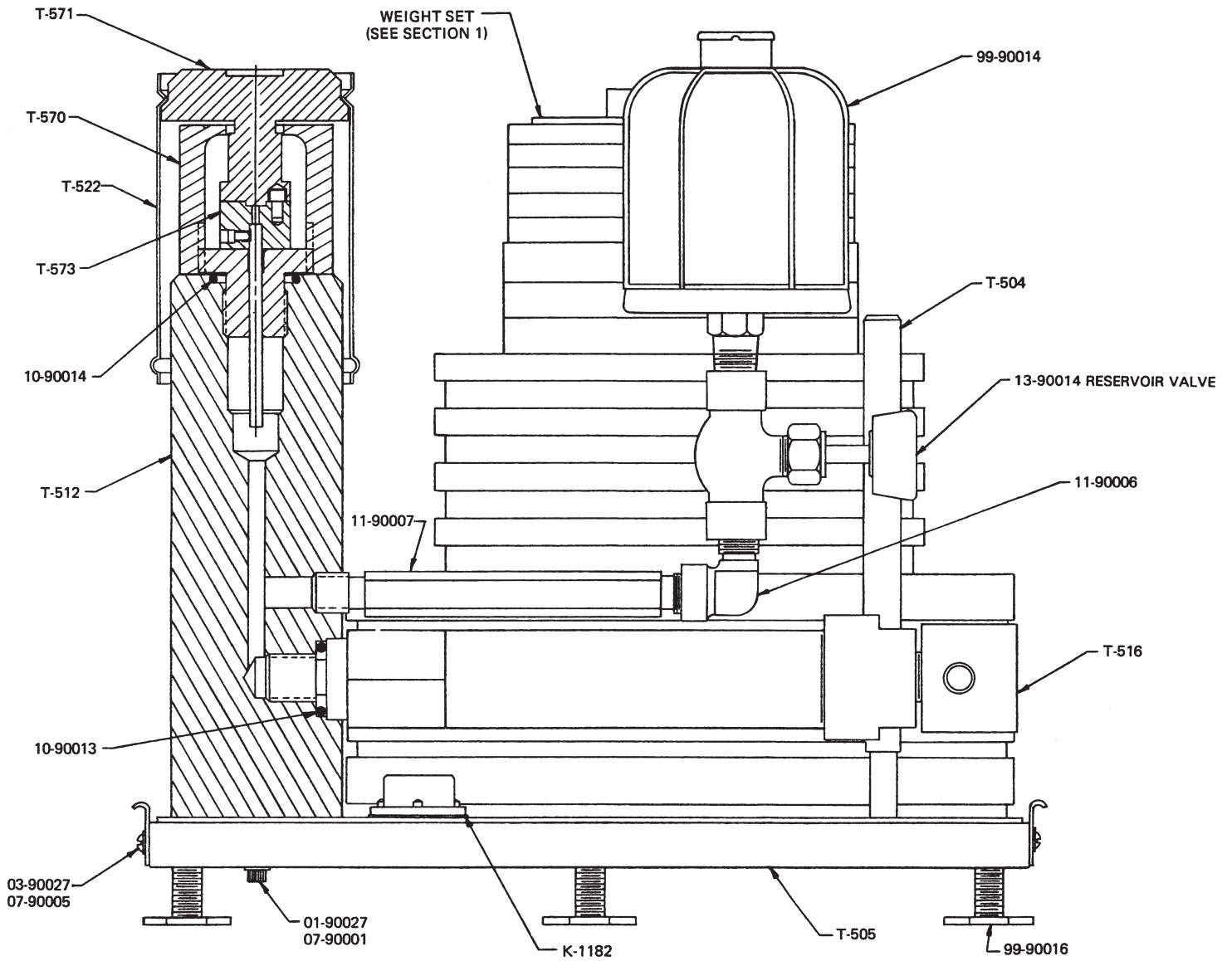

DRAWING TITLE		
<b>HYDRA-LITE TESTER</b>		
SIZE	CODE IDENT NO.	DWG. NO.
<b>B</b>	<b>92456</b>	<b>HL</b>
SCALE	RAW WT/ M	SHEET

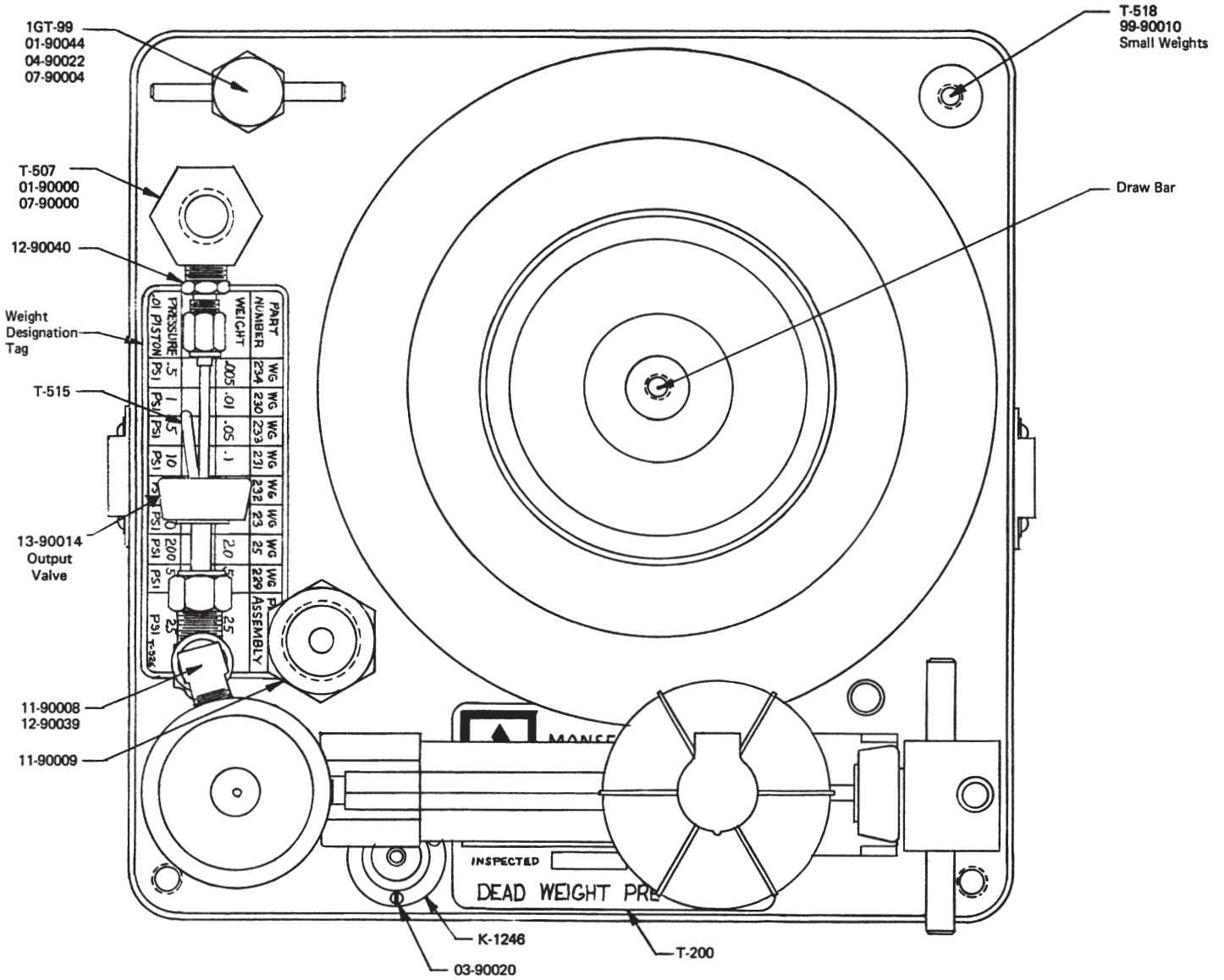

DRAWING TITLE		
<b>HYDRA-LITE TESTER</b>		
SIZE	CODE IDENT NO.	DWG. NO.
<b>B</b>	92456	<b>HL</b>
SCALE	RAW WT/M	SHEET

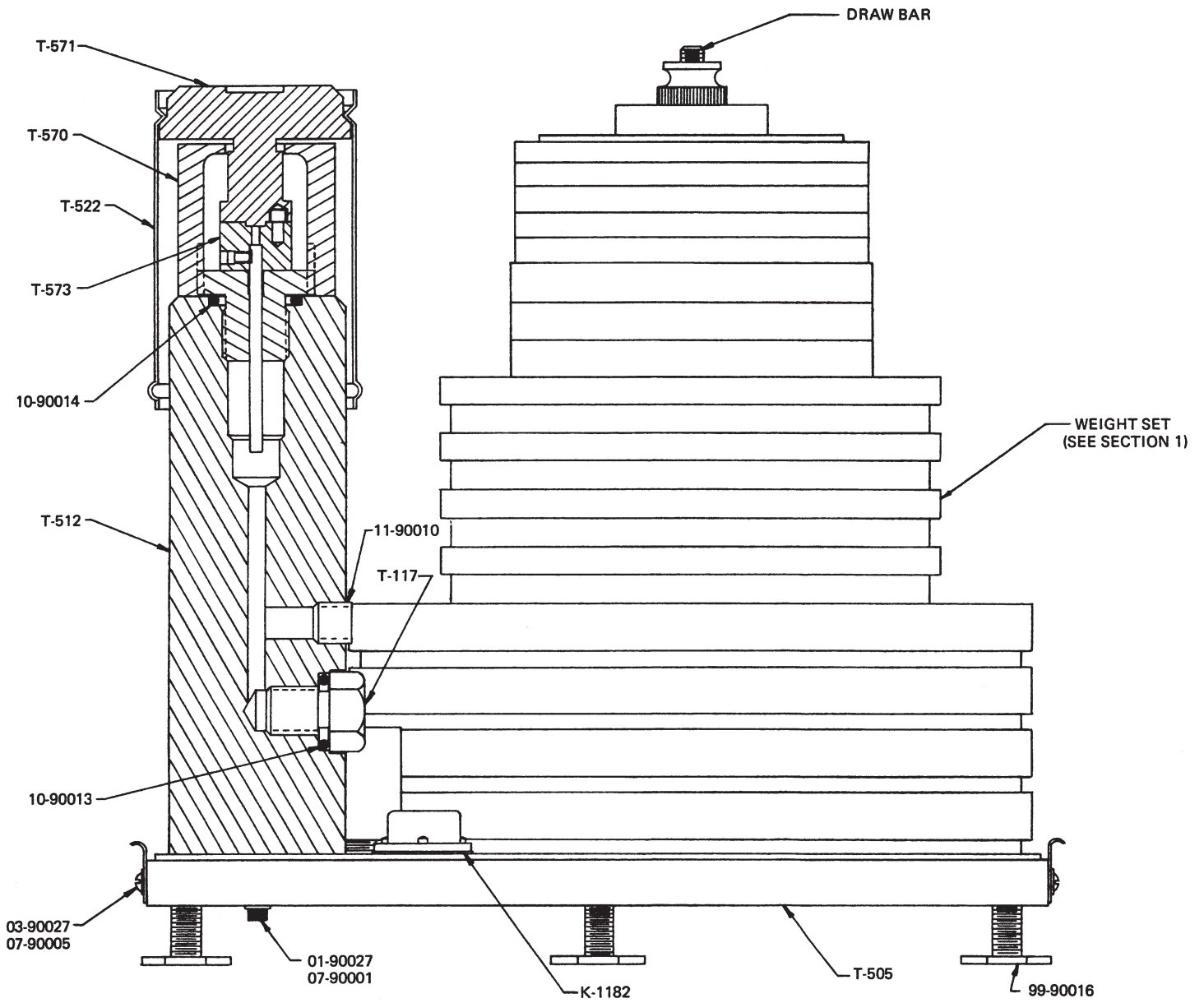

<b>AMETEK</b>		
DRAWING TITLE		
<b>HYDRA-LITE GAUGE</b>		
SIZE	CODE IDENT NO.	DWS. NO.
<b>B</b>	92456	<b>HLG</b>
SCALE	RAW WT/ M	SHEET

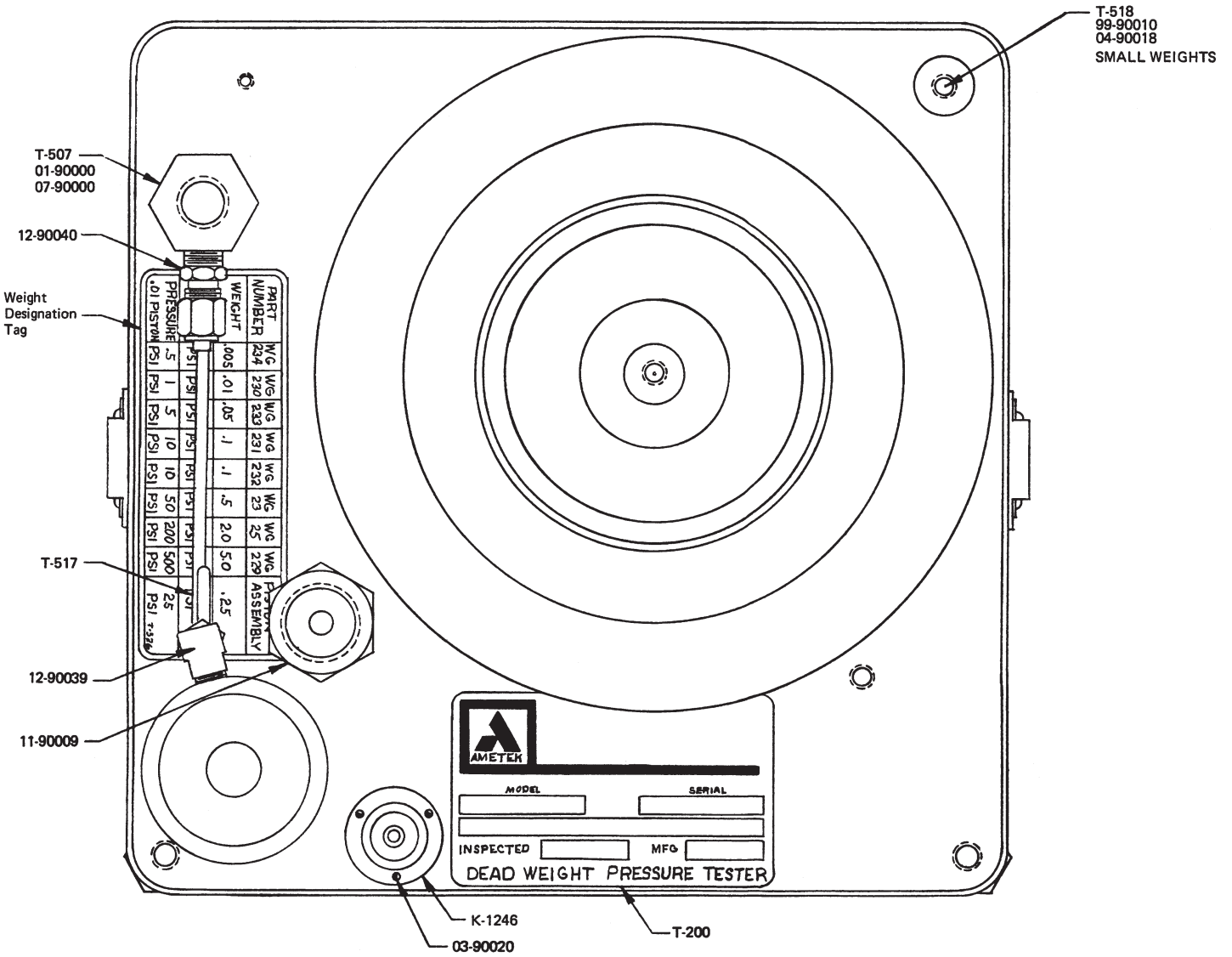

 <b>AMETEK</b>		
DRAWING TITLE		
<b>HYDRA-LITE GAUGE</b>		
SIZE	CODE IDENT NO.	DWG. NO.
<b>B</b>	92456	<b>HLG</b>
SCALE	RAW WT/M	SHEET



