

# Pomona<sup>®</sup>

**Model 3533**  
**Adapter**  
**BNC Male To Male**

**TRANSCAT**

▶ Visit us at [Transcat.com](http://Transcat.com)!

35 Vantage Point Drive // Rochester, NY 14624 // Call 1.800.800.5001

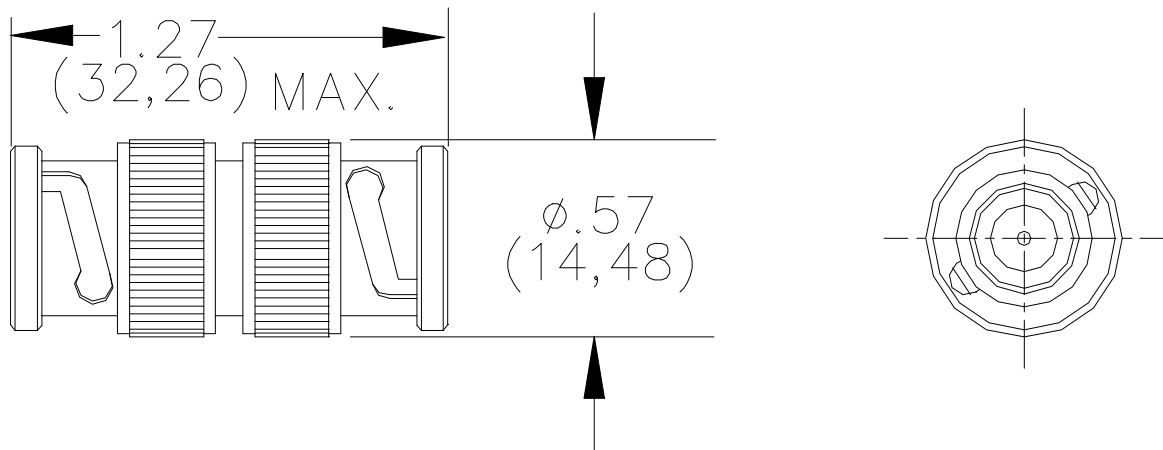

## **MATERIALS:**

Body – Brass, Tarnish Resistant Plating, Center Contact: Gold Plated Brass

Dielectric: PTFE

Finish: Body and Fittings – Tarnish Resistant

Center Contact – Gold Plated

Marking: “Pomona 3533”

## **RATING:**

Operating Voltage: Shield/Earth: 30VAC/60VDC Max.

Inner Conductor/Shield: 500VRMS Max.

Operating Temperature: -65°C to +165°C

Nominal Impedance: 50 Ohms

**ORDERING INFORMATION:** Model 3533

All dimensions are in inches. Tolerances (except noted): .xx = ±.02” (.51 mm), .xxx = ±.005” (.127 mm).

All specifications are to the latest revisions. Specifications are subject to change without notice.

Registered trademarks are the property of their respective companies. Made in USA

**TRANSCAT**

▶ Visit us at [Transcat.com](http://Transcat.com)!

35 Vantage Point Drive // Rochester, NY 14624 // Call 1.800.800.5001