



**PLEASE CHECK FOR CHANGE INFORMATION
AT THE REAR OF THIS MANUAL.**

**S-53
TRIGGER
RECOGNIZER
HEAD**

INSTRUCTION MANUAL

**Tektronix, Inc.
P.O. Box 500
Beaverton, Oregon 97077**

070-1147-00
Product Group 42

Serial Number _____

First Printing MAY 1971
Revised OCT 1987

Copyright © 1971 Tektronix, Inc. All rights reserved.
Contents of this publication may not be reproduced in any
form without the written permission of Tektronix, Inc.

Products of Tektronix, Inc. and its subsidiaries are covered
by U.S. and foreign patents and/or pending patents.

TEKTRONIX, TEK, SCOPE-MOBILE, and  are
registered trademarks of Tektronix, Inc. TELEQUIPMENT
is a registered trademark of Tektronix U.K. Limited.

Printed in U.S.A. Specification and price change privileges
are reserved.

INSTRUMENT SERIAL NUMBERS

Each instrument has a serial number on a panel insert, tag,
or stamped on the chassis. The first number or letter
designates the country of manufacture. The last five digits
of the serial number are assigned sequentially and are
unique to each instrument. Those manufactured in the
United States have six unique digits. The country of
manufacture is identified as follows:

B000000	Tektronix, Inc., Beaverton, Oregon, USA
100000	Tektronix Guernsey, Ltd., Channel Islands
200000	Tektronix United Kingdom, Ltd., London
300000	Sony/Tektronix, Japan
700000	Tektronix Holland, NV, Heerenveen, The Netherlands

TABLE OF CONTENTS

SECTION 1	SPECIFICATION	Page	SECTION 5	PERFORMANCE CHECK and CALIBRATION PROCEDURE	Page
	General Information	1-1		Introduction	5-1
	Electrical Characteristics	1-1		Equipment Required	5-1
	Environmental Characteristics	1-2		Performance Check Procedure	5-1
	Mechanical Characteristics	1-2		Calibration Procedure	5-5
SECTION 2	OPERATING INSTRUCTIONS		SECTION 6	ELECTRICAL PARTS LIST	
	General Information	2-1		Abbreviations	
	Installation	2-1		Parts Ordering Information	
	General	2-1		Special Notes and Symbols	
	Head Installation	2-1		Index	
	Extender Cable Installation	2-1		Electrical Parts List	
	Controls and Connectors	2-2	SECTION 7	DIAGRAMS	
	First Time Operation			Symbols	
	General Information	2-3		Component Locations	
	Procedure	2-3		Troubleshooting Waveforms	
	Using a Pretrigger	2-3		Diagrams	
	H.F. Triggering	2-3	SECTION 8	MECHANICAL PARTS LIST	
SECTION 3	CIRCUIT DESCRIPTION			Mechanical Parts Information	
	General Information	3-1		Mechanical Parts List	
	Block Diagram	3-1		Mechanical Parts Illustration	
	Circuit Description	3-2	CHANGE INFORMATION		
	Level and Slope	3-2		Abbreviations and symbols used in this manual are based on or taken directly from IEEE Standard 260 "Standard Symbols for Units", MIL-STD-12B and other standards of the electronics industry. Change information, if any, is located at the rear of this manual.	
	Schmitt Trigger	3-2			
	Arming and Start Tunnel Diode	3-2			
	Holdoff	3-3			
	Output	3-3			
SECTION 4	MAINTENANCE				
	Introduction	4-1			
	Obtaining Replacement Parts	4-1			
	Parts Removal and Replacement	4-1			
	Housing and Rear Panel	4-1			
	Circuit Boards	4-1			
	Parts Locations	4-2			
	Troubleshooting	4-2			
	Repackaging for Shipment	4-2			



Fig. 1-1. S-53 Trigger Recognizer Head.

SECTION 1

SPECIFICATION

Change information, if any, affecting this section will be found at the rear of this manual.

General Information

The S-53 Trigger Recognizer Head produces a stable trigger signal from input signals from DC to 1 GHz. The trigger output signal is available at the front and rear panels of the S-53 to permit triggering of a sampling time-base unit.

The operating power for the S-53 is obtained when the unit is installed into a head compartment (or connected via an interconnecting cable) in Tektronix sampling instruments. The S-53 may be used with a Type 3S2, 3S5, or 3S6 in place of one of the sampling heads. The 7S12 will accept

the S-53 in place of the pulse generator, and thus operate as a general purpose sampling oscilloscope. The S-53 will also operate separately with the Type 285 Power Supply.

Electrical Characteristics

The following characteristics apply over an ambient temperature range of 0°C to +50°C after a 10 minute warmup for an instrument that was calibrated at a temperature between +20°C and +30°C. The required operating voltages are applied to the instrument when it is connected or installed into the sampling head compartment, or powered by a sampling head power supply.

ELECTRICAL CHARACTERISTICS

Characteristics	Performance Requirement	Supplemental Information
INPUT Signal		
Frequency	DC to 1 GHz	
Sensitivity Range	10 mV to 1 V P-P into 50 Ω	2 V P-P maximum
TRIG OUT Signal		
Amplitude	At least 1 V into 50 Ω positive-going	
Rise Rate	600 mV/ns	
Pulse Duration	3 ns within 2 ns at 50% amplitude level	
Period (minimum)	27 μ s within 2.5 μ s with input signals above 50 kHz.	
INPUT Signal to Trigger Out Signal Delay Time	15 ns or less	Conditions for Test: Use a fast rise signal (or high frequency source with low amplitude modulation) with amplitude of at least 200 mV, 7M11 50 Ω Delay Line, and 7S12.
INPUT Signal to Trigger Out Signal Jitter	15 ps or less	
Kickout at Input	\pm 10 mV or less	

ENVIRONMENTAL CHARACTERISTICS

Characteristics	Performance Requirement	Supplemental Information
Temperature		
Non-operating		-40°C to +65°C
Operating		0°C to +50°C
Altitude		
Non-operating		To 50,000 feet
Operating		To 15,000 feet
Vibration (Non-operating)		15 minutes along each axis at 0.015 inch. Vary the frequency from 10 to 55 to 10 Hz in 1-minute sweeps. Three minutes at any resonant point or at 55 Hz.
Shock (Non-operating)		Two shocks each of 500 g's (2 ms duration), 750 g's (1 ms duration) and 1000 g's (0.5 ms duration), in each direction and along each major axis for a total of 36 shocks.
Transportation		Meets National Safe Transit Committee type of test when packaged as shipped by factory.

MECHANICAL CHARACTERISTICS

Characteristics	Description
Finish	Anodized aluminum front panel, extruded aluminum blue-vinyl painted cabinet with aluminum castings front and rear.
Weight	Approximately 8 oz.
Dimensions	
Height	About 2 inches
Width	About 1 3/4 inches
Length	About 4 inches

SECTION 2

OPERATING INSTRUCTIONS

Change information, if any, affecting this section will be found at the rear of this manual.

General Information

This section of the manual provides the basic information required for operation of the S-53 Trigger Recognizer head, and includes installation and First Time Operation instructions.

The S-53 may be powered by any Tektronix instrument containing a sampling head compartment such as Tektronix 7S12, 7S11, or Types 3S2, 3S5, 3S6, or 286; or the unit may be powered separately by a Tektronix Type 285 Power Supply for S-50 Series Heads. The S-53 may be connected to a head compartment by one of two accessory extender cables. This permits a short length coaxial cable to be used to connect the input trigger signals.

A fast trigger output signal at the front and rear panel connectors which can be synchronized with input signals up to 1 GHz, makes the S-53 useful for an input triggering unit. The S-53 can be used in the Pulse Generator compartment of the 7S12 TDR Sampler unit to convert the unit to a general purpose sampling unit.

INSTALLATION

General

Since the S-53 Trigger Recognizer Head can be powered by Tektronix instruments containing sampling compartments or sampling head extender cables, many combinations of instruments are possible. Two general methods of installation are shown in Fig. 2-1. Part (A) shows the S-53 installed in the pulse generator compartment of the Tektronix 7S12 TDR Sampler unit. This allows the 7S12 to be used as a general purpose sampling unit. The 7S12 can be installed in any 7000 series oscilloscope. Part (B) shows the S-53 installed in the head compartment of the Type 285 Power Supply.

With either method of installation, the S-53 can be plugged into the sampling unit or powered as shown, or used remotely on a special extender cable. Three and six foot extender cables are available. Order the three foot extender cable by Tektronix Part No. 012-0124-00, or the six foot extender cable by Tektronix Part No. 012-0125-00. Contact your local Tektronix Field Office or representative for price and availability of these optional accessories.

Head Installation

To insert the S-53 into a compartment of the sampling unit or power supply, proceed as follows:

1. Pull the latch knob outward from the front panel (the latch knob will push out normally when the unit is inserted if the knob is left free to move).
2. Insert the unit slowly into the compartment, so the two plastic guides enter the rear connector opening.
3. Push the S-53 completely into the compartment.
4. Push the latch knob to lock the unit in place.

To remove the S-53 from the compartment, pull the latch knob away from the front panel, then pull the unit from the compartment.

Extender Cable Installation

To use the S-53 on an extender cable, install as follows:

1. Pull the latch knob extender outward from the panel (the latch knob will push out normally when the extender is inserted if the knob is free to move).
2. Insert the extender cable head end slowly into the desired compartment in the sampling unit so the two plastic guides in the compartment engage the unit.
3. Push the head completely into the compartment.
4. Push the latch knob to lock the extender cable head end in place.
5. Connect the S-53 to the other end of the extender cable in a similar manner, and set the latch knob to hold it in place.

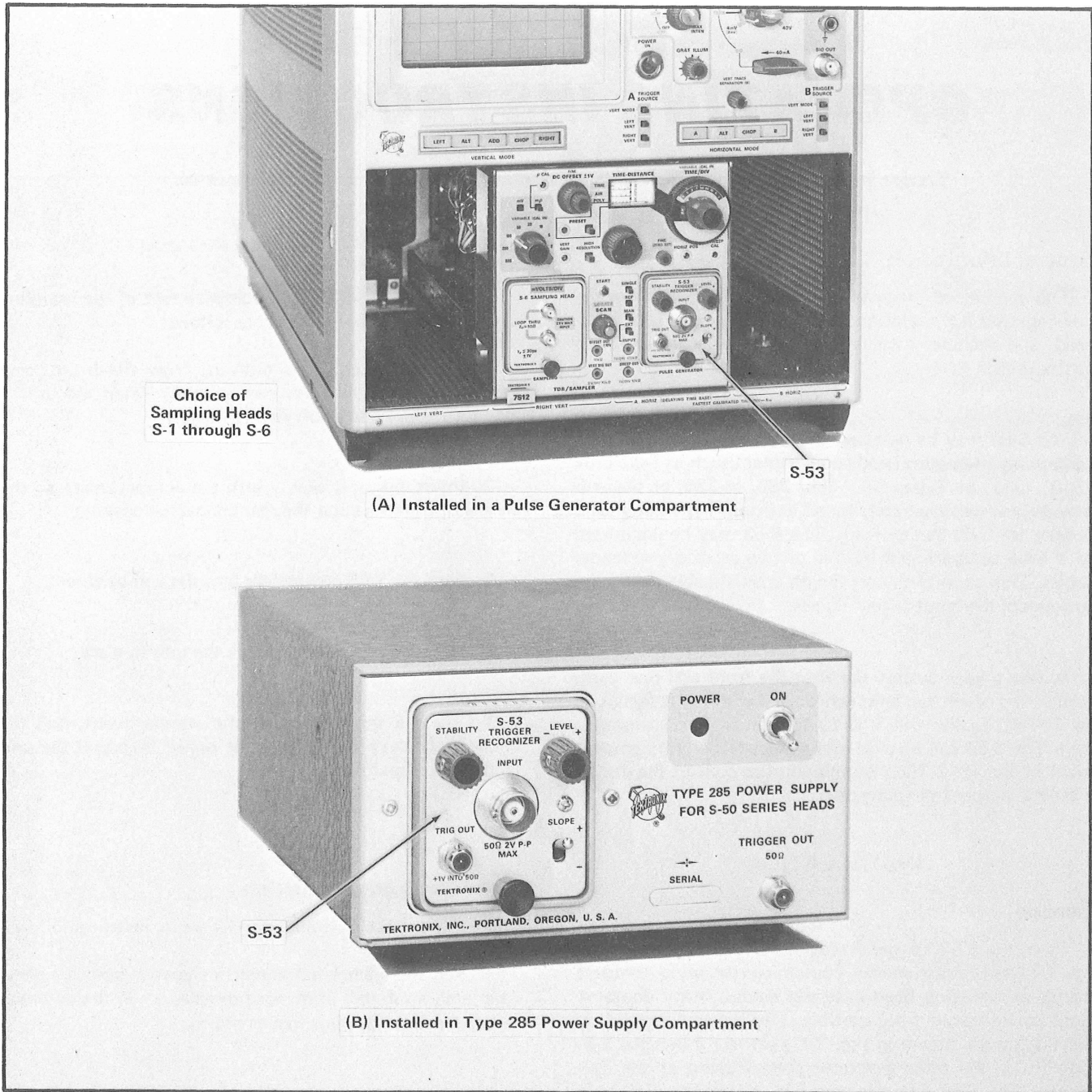

Fig. 2-1. S-53 Installation Information.

6. To remove the S-53 from the extender cable, pull the latch knob on the front panel of the S-53 and remove the unit from the extender cable.

7. To remove the extender cable head from the sampling unit compartment, pull the latch knob outward from the front of the panel, then pull the extender cable free.

CONTROLS AND CONNECTORS

A brief description of the function and operation of the controls and connectors of the S-53 follows:

SLOPE

Selects + (the positive-going) or - (the negative-going) slope of the triggering signal.

LEVEL	Determines the amplitude level on the triggering waveform where triggering is to occur. Also serves as a fine sync adjustment with the STABILITY control during HF sync operation.
STABILITY	Adjusts the width of the Trigger hysteresis. Also serves as a coarse sync adjustment to place the S-53 HF sync operation.
INPUT	BNC type connector that accepts all triggering signals used in the S-53.
TRIG OUT	BSM type connector, provides a positive pulse from the Trigger circuit.
Trigger Out	Rear Panel coaxial connector, provides positive pulse from the Trigger circuit for triggering standard sampling time-base unit.

Vertical Mode	Right
Horizontal Mode	A

7S12 with S-6 and S-53

(Two center compartments, the right vertical and the A horizontal compartments.)

Time Distance dial	0
Multiplier	X.1
Time/Div	5 ns
Variable	Cal in
Fine (Zero Set)	Fully clockwise
Rep	pushed in
Scan	Midrange
Locate	pushed in
mV	pushed in
mV/Div	100
DC Offset (& Fine)	Midrange

S-53

STABILITY	Fully clockwise
LEVEL	Midrange
SLOPE	+

FIRST TIME OPERATION

General Information

One of the important uses for the S-53 Trigger Recognizer head is to convert the 7S12 TDR/Sampler plug-in unit to a general purpose sampling unit by providing an internal trigger output from a wide range of signal inputs. This First Time Operation uses the S-53 installed in the Pulse Generator compartment of the 7S12 as shown in Fig. 2-1A. Other sampling heads can be substituted for the S-6, depending upon the signal inputs and risetime required. Tektronix Type 284 Pulse Generator is used to provide signals to the S-53 and S-6.

Procedure

1. Insert the 7S12 TDR/Sampler into the center two compartments of the 7504 Oscilloscope. Any Tektronix 7000-series Oscilloscope may be substituted for the 7504.
2. Install the S-53 in the Pulse Generator compartment.
3. Install the S-6 in the 7S12 Sampling compartment.
4. Set the controls as follows:

7504 Indicator Oscilloscope

A Intensity	CCW
B Intensity	CCW

5. Turn on the Type 284 and the Oscilloscope Power. After about a 5 minute warmup time, advance the A Intensity until a free running trace is observed. Center the trace on the CRT with the 7S12 DC Offset control.

Using a Pretrigger

6. Install a SMA (3 mm) termination connector to the S-6 Loop Thru (upper) connector. Connect the Type 284 Pulse Output signal through a GR to BNC adapter, a BNC coaxial cable, and a BNC to SMA (3 mm) adapter to the S-6 Loop Thru (lower) connector. Connect the Type 284 Trigger Output signal (Lead Time 75 ns) through a BNC coaxial cable to the S-53 INPUT connector.

7. Turn the S-53 STABILITY control fully counter-clockwise, and set the LEVEL control for a stable display of the Type 284 Pulse Output signal. See Fig. 2-2.

H.F. Triggering

8. Disconnect the Type 284 Pulse Output cable and connect the Type 284 1 ns Period sine wave output signal through a GR to BNC adapter, a BNC coaxial cable, and a BNC to SMA (3 mm) adapter to the S-6 Loop Thru (lower) connector.

9. Change the Time/Div to 1 ns and set both the S-53 STABILITY and the LEVEL control for a stable sine wave display; see Fig. 2-3.

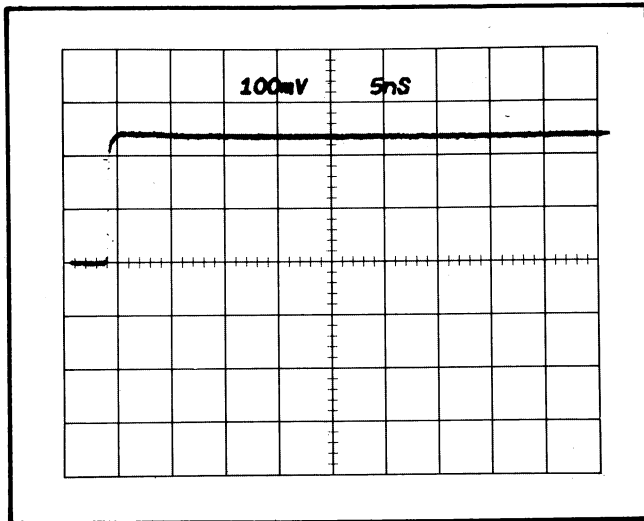

Fig. 2-2. Type 284 Pulse Output signal display using a pretrigger.

The Trigger source signal to the S-53 INPUT can be obtained from the test signal by using a tee connection, by using a power divider, or by using the Feed Thru (upper) connector of the S-6. To use the Feed Thru (upper) connector of the S-6 to obtain the trigger source, connect as follows:

10. Remove the $50\ \Omega$ termination from the S-6 Feed Thru (upper) connector, and install a SMA (3 mm) to BNC adapter in its place. Remove the BNC coaxial cable connected to the S-53 INPUT and connect a short BNC coaxial cable from the S-53 INPUT connector to the BNC to SMA adapter installed on the S-6 Feed Thru (upper) connector.

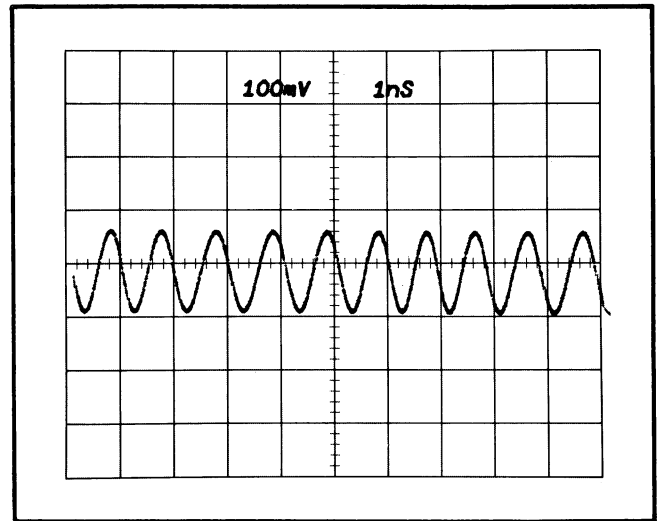
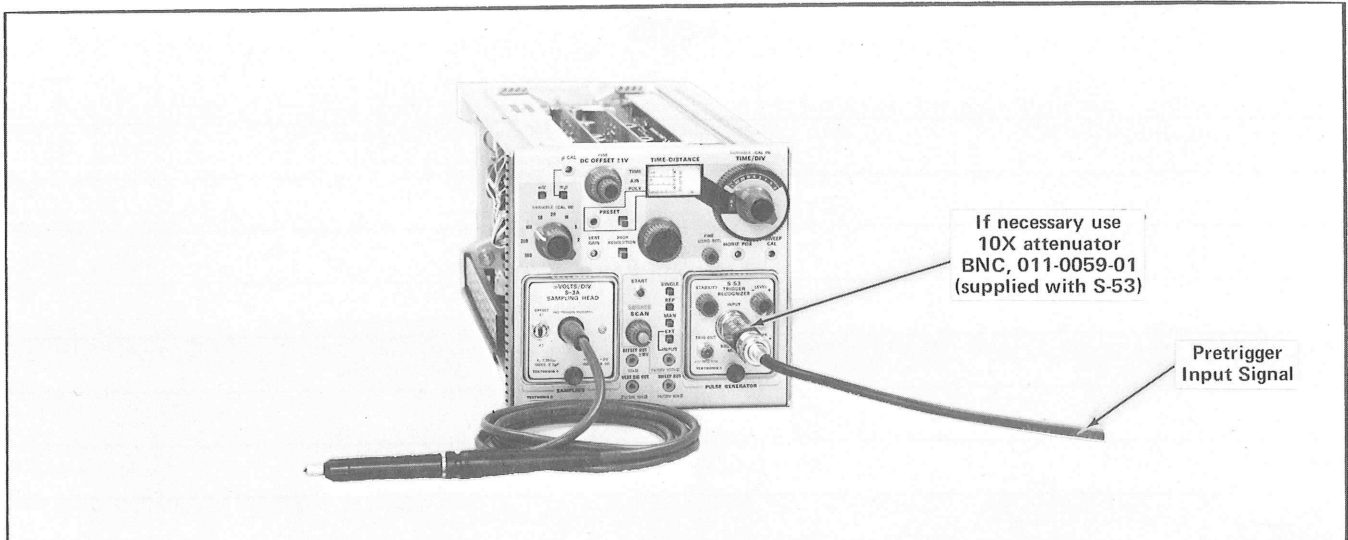

Fig. 2-3. 1 ns period sine wave display.

11. Set both the STABILITY and the LEVEL control for a stable sine wave display.

Fig. 2-4 shows the setup information for two applications to convert the 7S12 into a general purpose sampling unit with the S-53.

When the Type 285 Power Supply is used to furnish the power to the S-53 as shown installed in Fig. 2-1B, both trigger output signals are available at the front panel; one from the S-53 TRIG OUT connector, and one from the Type 285 Trigger Out connector. Either connector provides a positive pulse from the trigger circuit for triggering standard sampling time-base units or other devices.



(A) General Purpose sampling operation using a pretrigger. Choose the sampling head for your application.

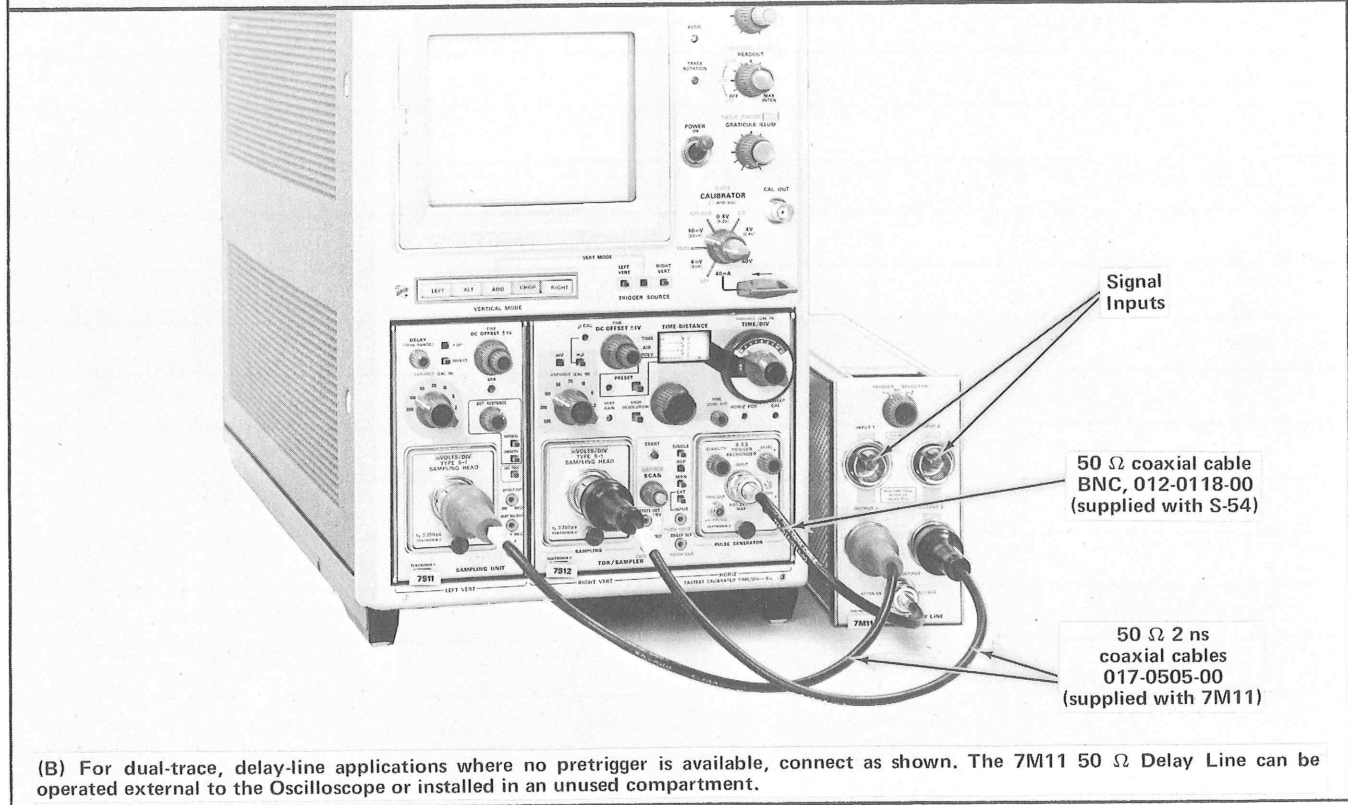

(B) For dual-trace, delay-line applications where no pretrigger is available, connect as shown. The 7M11 50 Ω Delay Line can be operated external to the Oscilloscope or installed in an unused compartment.

Fig. 2-4. General Purpose sampling applications.

SECTION 3

CIRCUIT DESCRIPTION

Change information, if any, affecting this section will be found at the rear of this manual.

General Information

This section of the manual contains the electrical description of the S-53 Trigger Recognizer Head circuits.

The S-53 requires +15 V and -12.2 V input power. The input power is obtained when the instrument is connected to the pulse generator compartment connector of a TDR/Sampler unit, to one compartment connector of a dual-trace sampling unit, or to the Type 285 Power Supply.

Refer to the schematic diagram in Section 7 of the manual as necessary during the Circuit Description.

BLOCK DIAGRAM

The Block diagram, Figure 3-1, shows the major circuit blocks of the S-53. A brief description of each block follows, starting with the Level and Slope block.

The S-53 trigger input signals are connected through the front panel INPUT connector to the Level and Slope amplifier. The front panel SLOPE switch selects the positive or negative going portion to be used, and the front panel

LEVEL control sets the level of the input signal at which triggering will occur. At this triggering point, the amplifier drives a current signal to the Schmitt Trigger block.

When the Schmitt Trigger is driven by the current signal from the Level and Slope, it produces a fast pulse to drive the Arming and Start Tunnel Diode. The front panel STABILITY control provides a means of setting the sensitivity of the Schmitt trigger circuit.

When the tunnel diodes are armed in the Arming and Start Tunnel Diode block, the fast trigger pulse from the Schmitt Trigger operates the circuit to provide a fast output. The Holdoff block provides a minimum holdoff time between triggers and resets the tunnel diodes.

The output amplifies the fast positive step from the Arming and Start Tunnel Diodes to provide a fast positive pulse to the front and rear panel trigger out connectors.

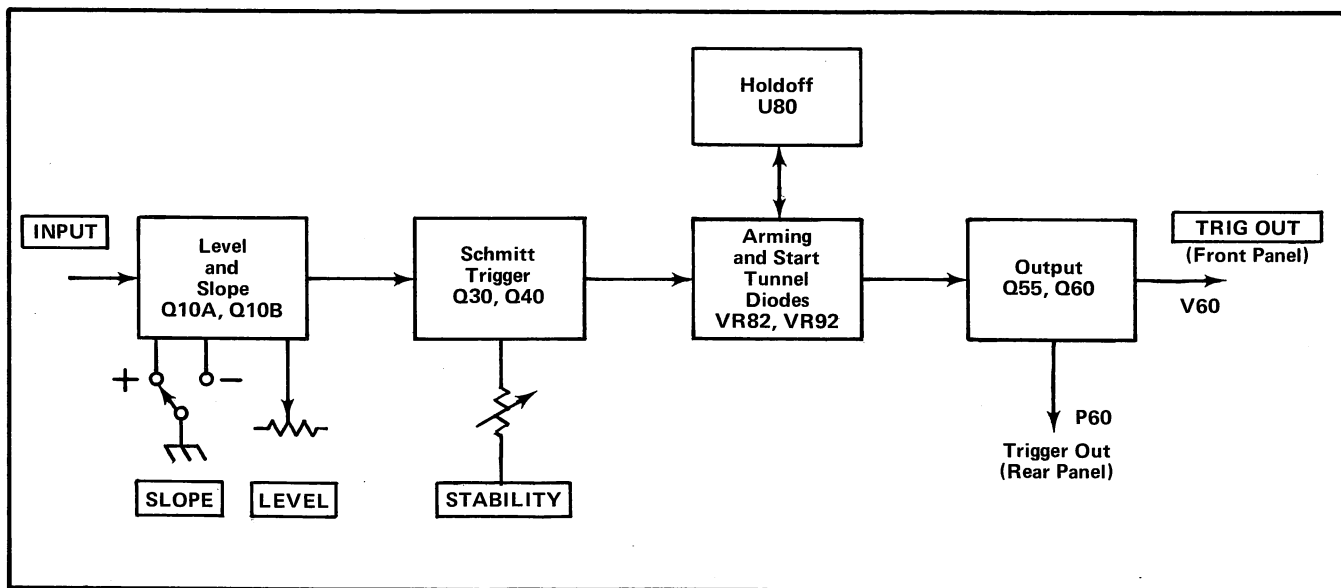

Fig. 3-1. S-53 Block diagram.

CIRCUIT DESCRIPTION

Level and Slope

The Level and Slope Amplifier consists of Q10, Q12, Q20, Q22 and associated components. The input to the circuit is from the front panel INPUT connector, and the output current from the common connection of R26, R20, and R22 drives the Schmitt Trigger circuit.

Q10 and Q12 are connected as a differential amplifier. With the LEVEL control set to midrange, and no input signal at J10, current in each transistor is about 5 mA. Assume that the + SLOPE is selected as shown in the diagram in Section 7. Q20 is reverse biased, and Q22 is conducting. The TRIG ZERO adjustment allows the current to be set to drive the Schmitt Trigger circuit.

With a positive input signal, above the level set by the LEVEL control, Q10 and Q12 cause current in Q22 to increase. When the - SLOPE is selected, Q22 is reverse biased and Q20 is conducting. With a negative input signal below the level set by the LEVEL control, Q10 and Q12 cause current in Q20 to increase. The increase in current in Q20 or Q22 increases the current to the Schmitt Trigger circuit.

Schmitt Trigger

The Schmitt Trigger circuit consists of Q30, Q40, tunnel diode CR25, and associated components. The circuit is driven by a current signal from the Level and Slope circuit through Q20 or Q22. The positive output signal is coupled through C49 to the Arming and Start Tunnel Diode circuit at Q50 base.

The tunnel diode, CR25, is connected into the positive feedback circuit of the amplifier so that an increase in the tunnel diode current will be amplified by the circuit. Once the tunnel diode has changed state in response to an increase current signal, the circuit reduces current in the tunnel diode so that it will revert to the low state when the input current signal is removed.

Input current from the common connection of R22, R20, and R26 is set by the Trig Zero, R25, during calibration to arm the tunnel diode. Part of the input current path is through R28-Q30, and the remainder is through CR25-Q40. Additional current to this circuit is supplied from +15 V through R29 and R41.

With CR armed, the next increase in current signal from the Level and Slope circuit caused an increase of current in the tunnel diode, CR25. Even if this initial increase

in current does not cause the tunnel diode to change to its high state, this change may still occur due to amplification in the circuit. Any increase in tunnel diode current produces a change in voltage at Q40 collector. A part of this voltage change, as determined by the settings of the Stability Zero Set adjustment and the STABILITY control, appears at the emitter of Q30 as a decrease in forward bias. This results in a larger percentage of current from R29. When CR25 current is sufficient to cause it to change to its high state, a positive signal is produced, and coupled through C49 to Q50 base and the 3 ns delay line in the Arming and Start Tunnel Diode circuit.

When CR25 changes to the high state, less current is supplied by the Level and Slope circuit, which results in a lower current in Q40. The decrease in Q40 current is sensed by Q30, and thus R29 supplies less current to CR25. Current is decreased to a point where removal of the initial current signal from Q20 or Q22 in the Level and Slope circuit will cause CR25 to return to its low state. Current from the Level and Slope circuit, as set by the Trig Zero adjustment, will again arm CR25 for the next current signal.

Arming and Start Tunnel Diode

The Arming and Start Tunnel Diode circuit consists of Q50, CR82 (the Arming tunnel diode) CR92 (the Start tunnel diode), a 3 ns delay line, and associated components.

The circuit is triggered from a fast positive pulse from CR25, and is controlled by the Holdoff circuit at U80A and B collectors. Circuit output at CR92 anode drives the Holdoff and Output circuits.

Before a trigger input signal, the Holdoff circuit transistors U80A and B must be cut off to allow arming current for CR82 and CR92. Arming current for CR82 is set by R82, and arming current for CR92 is set by R92. These controls set the current below the peak value requirement of each tunnel diode. Final arming of CR92 is accomplished when CR82 changes to its high state.

With CR82 armed, the next positive input signal through C49 drives Q50 base and the 3 ns delay line. The increased conduction of Q50 couples a positive pulse through C50 and R51 to cause CR82 to change to its high state. With CR82 changed to its high state, the arming current of CR92 is increased, and CR92 is fully armed. The positive trigger signal from the 3 ns delay line through R52 causes CR92 to change to its high state. This positive output signal at CR92 anode drives the Output circuit through CR51, and the Holdoff circuit through R67.

Further operation of the Arming and Start Tunnel Diode circuit occurs when the Holdoff circuit turns on U80A and B, which reduces the current to the tunnel diodes CR82 and CR92 causing them to change to their low states. Later U80A and B are reverse biased, and the arming current to the tunnel diodes is re-established.

Holdoff

The Holdoff circuit, consisting of U80 and associated components, is driven by the positive step pulse from the Start tunnel diode. The circuit output at U80A and B collector controls the arming current of the Arming and Start tunnel diodes.

The quiescent conditions of the circuit are as follows: the Start tunnel diode, CR92, is armed (at its low state) and U80E is reverse biased. VR67, CR67, and CR68 are conducting, and C70 is charged to about 6.2 V. U80D base current in R73 turns on U80D (emitter at zero volts) and CR70 is reverse biased. With U80D on, U80A, B and C are reverse biased.

When CR92 changes to its high state, this positive voltage through R97 and R67 forward biases U80E. With U80E on, its low collector voltage reverse biases CR68 and allows C70 to charge through R70. C70 charges to a value which causes CR70 to conduct and reverse bias U80D. With U80D reverse biased, U80C base current in R75 causes U80C to conduct (emitter near +5 V), and turn on U80A and B. With U80A and B on, the current to CR82 and CR92 is reduced. This reduction in current causes CR82 and CR92 to change to their low stages. Also when U80A is on, U80E becomes reverse biased. This allows CR68 to conduct and

charge C70 toward 6.2 V. C70 voltage rises and is coupled by CR70 to U80D base until U80D is forward biased and its base conducts enough current through R73 to reverse bias CR70. With U80D on, U80A, B, and C are reverse biased. The circuit is ready for another Start tunnel diode positive signal.

Output

The Output circuit amplifies the positive step from the Start tunnel diode to provide a trigger output pulse to the front and rear panel connectors.

Before the input pulse, CR51 conducts, forward biasing Q55. Q55 conducts with its current path from +15 V through R58, R57, Q55, and R55 to the -12.2 V. Q55 collector current is low, and Q60 does not conduct.

When CR92, in the Arming and Start Tunnel Diode circuit, changes to its high state, a positive signal is coupled through CR51 to Q55 base. Q55 increases conduction through C60 and turns on Q60. Q60 collector goes positive and feedback occurs through R62 and C62 to Q55 base. CR51 is reverse biased. Fast regeneration of the circuit is caused by C57, C60, and C62. The fast positive pulse at the collector of Q60 is coupled to the TRIG OUT connector (J60) on the front panel through C65 and CR65, and to the rear panel connector (P60) through C61 and CR61.

After this fast regeneration, Q60 cuts off, and C60 charges to set Q55 emitter at a low voltage level allowing CR51 to conduct.

SECTION 4

MAINTENANCE

Change information, if any, affecting this section will be found at the rear of this manual.

Introduction

This section of the manual is a maintenance guide for the S-53 Pulse Generator Head. Information is included for parts ordering, parts removal and replacement, disassembly and assembly.

Obtaining Replacement Parts

All parts used in the S-53 can be purchased directly through your local Tektronix Field Office or representative. However, replacements for standard electronic items can be obtained locally. Consult the Electrical or Mechanical Parts List to determine the value, tolerance and rating required.

NOTE

When selecting replacement parts, it is important to remember that the physical size and shape of a component may affect its performance at high frequencies. After repair, the S-53 Pulse Generator Head may require re-calibration.

Parts Removal and Replacement

Housing and Rear Panel. To remove the S-53 from its housing, loosen the four retaining screws on the rear panel. Slide the rear panel off, and remove the housing by sliding it to the rear. With the housing and rear panel removed, the unit can be connected to an extender cable for access to adjustment controls and circuit test points for calibration. Two lengths of extender cables are available from your local Tektronix Field Office or representative. Order by Tektronix Part No. 012-0124-00 for the three-foot length and Tektronix Part No. 012-0125-00 for the six-foot length extender cable.

To install the S-53 in its housing, check that the upper and lower corners of the T.D. Driver and Delay Line board are aligned with the channels in the housing which contain the zigzag springs. Push the S-53 gently into the housing until it contacts the front panel. Be sure that the white plastic pawl in the locking knob is properly aligned as the S-53 is slid into the housing. Attach the rear casting, making sure that the hole on

one side fits over the trigger output signal connector. Insert the four long mounting bolts and tighten them securely. To ensure that the mounting bolts align with the front panel, hold the S-53 in its normal horizontal position; start the lower bolts, then turn the S-53 over and start the remaining two bolts.

Circuit Boards. To remove the T.D. Driver board, free the Delay Line coaxial cable from the slot in the Pre-Trigger (center) board and gently pull the board outward from the Pre-Trigger board. This allows access to both sides of both boards. To remove the trigger coaxial lead from the front panel, use a 5/16-inch end wrench to hold the nut located behind the front panel. Then use a 9/32-inch end wrench to remove the coaxial cable retaining nut. Once this nut is removed, gently pull the coaxial cable, together with the connector center pin, from the connector. Remove the connector shell, by first loosening the nut located behind the front panel with the 5/16-inch end wrench. The Delay Line is soldered to each board. To unsolder the Delay Line, care should be taken not to overheat the board or parts on the boards (example: carefully unsolder CR92 on the T.D. Driver board before unsoldering the Delay Line). To install the Timing board, reverse the procedure. (When inserting the coaxial cables, be sure that the outer braid is not shorted to the center conductor).

To remove the Pre-Trigger board; the connecting wire from the center conductor of the PULSE OUTPUT connector and the wires connecting the front panel controls must be unsoldered.

Use the following procedure:

1. Unsolder the wire from the center conductor of the BNC connector.
2. Unsolder the wires from the front panel controls.
3. With a 5/64-inch allen wrench, remove the two screws holding the Pre-Trigger board to the BNC connector assembly. Remove the Pre-Trigger board from the connector.

4. To install the Pre-Trigger board, reverse the procedure. Be sure the two spiral pins are flush with the connector holder before tightening the allen screws.

Parts Location

Photos of the T.D. Driver and Pre-Trigger boards, with the component locations, are shown in Section 7. The Mechanical Parts Illustration in Section 8 shows locations of the mechanical parts.

Troubleshooting

As an aid to troubleshooting, use the troubleshooting conditions listed on the schematic diagram page in Section 7. A preliminary condition is to determine if the sampling unit or Power Supply is providing the proper power to the S-53. The waveform conditions are given using the TRIG OUT signal to trigger the test oscilloscope. If necessary, use internal triggering (if no TRIG OUT signal) to isolate the inoperative circuit.

A TRIG OUT signal should be available when the STABILITY control is fully clockwise and the LEVEL control midrange. This also checks the free-run operation of the Schmitt trigger circuit.

Without an input signal to the S-53, set the STABILITY control counterclockwise. The Schmitt trigger circuit should not free-run and no TRIG OUT signal should be available. For further information on the Schmitt circuit and other circuits, refer to the Circuit Description Section.

Repackaging for Shipment

If the Tektronix instrument is to be shipped to a Tektronix Service Center for service or repair, attach a tag showing: owner (with address) and the name of an individual at your firm that can be contacted, complete instrument serial number and a description of the service required.

Save and re-use the package in which your instrument was shipped. If the original packaging is unfit for use or not available, repackage the instrument as follows:

Surround the instrument with polyethylene sheeting to protect the finish of the instrument. Obtain a carton of corrugated cardboard of the correct carton strength and having inside dimensions of no less than six inches more than the instrument dimensions. Cushion the instrument by tightly packing three inches of dunnage or urethane foam between carton and instrument, on all sides. Seal carton with shipping tape or industrial stapler.

The carton test strength for your instrument is 200 pounds.

SECTION 5

PERFORMANCE CHECK/CALIBRATION

Change information, if any, affecting this section will be found at the rear of this manual.

Introduction

This section of the manual contains the Performance Check and the Calibration Procedure. When the Performance Check Procedure is completed, the instrument is checked to the "Performance" information given in Section 1. The tolerances and waveforms given in the Calibration Procedure should be considered only as calibration guides, and not as instrument specifications.

Equipment Required

The following test equipment, or its equivalent is required for both the Performance Check Procedure and the Calibration Procedure of the S-53. All test equipment must be calibrated. If other equipment is substituted, it must meet or exceed the limits stated in the equipment list.

1. Oscilloscope; 7000-Series such as 7704 to accept plug-in units listed in item 2.
2. 7S12 TDR/Sampler.
3. S-6 Sampling Head.
- 4.1 S-1 Sampling Head. (Used only to check kickout signal in Performance check step 5.)
5. 7M11 50 Ω Delay Line.
6. Test Oscilloscope, 10X probe, 20 MHz Bandwidth, 5 μ s/div, 5 V/div. (Used only to check TRIG OUT Period, Performance check step 6.)
7. Type 284 Pulse Generator.
8. 50 Ω coaxial cable, 1 ns, SMA (3 mm) connectors, Tektronix Part No. 015-1023-00 (supplied with S-52).
9. Two Coaxial cables, 50 Ω , 42 inch, BNC connectors, Tektronix Part No. 012-0057-01 (one supplied with S-53).

10. Coaxial cable, 50 Ω , 18 inch, BNC connectors, Tektronix Part No. 012-0076-00.

11. Three adapters, GR to BNC Female, Tektronix Part No. 017-0063-00.

12. Adapter, SMA (3 mm) Male to BNC Female, Tektronix Part No. 015-1018-00.

13. Adapter, GR to BNC Male, Tektronix Part No. 017-0064-00.

14. Adapter, SMA (3 mm) Female to Female, Tektronix Part No. 015-1012-00 (supplied with S-6).

15. Adapter, BSM Male to BNC Female, Tektronix Part No. 103-0036-00.

16. 50 Ω termination male, SMA (3 mm) Tektronix Part No. 015-1022-00 (supplied with S-6).

17. 50 Ω 5X attenuator, BNC Tektronix Part No. 011-0060-02.

18. BNC T connector, Tektronix Part No. 103-0030-00.

19. Variable Attenuator with GR874 connectors. It consists of a 100 Ω potentiometer across a 50 Ω line, and does not have a guaranteed response. Tektronix Part No. 067-0511-00.

20. Sampling-Head extender, 3 foot. Tektronix Part No. 012-0124-00.

PERFORMANCE CHECK PROCEDURE

Introduction

The Performance Check provides a means of rapidly checking the S-53 without adjusting any internal con-

Performance Check/Calibration—S-53

trols. Failure to meet any of the requirements given in this procedure indicates a need for internal checks or adjustments, and the user should refer to the Calibration Procedure in this section.

Preliminary Procedure

1. Assemble the equipment as follows: Install the 7S12 in the center two compartments of the 7504 Oscilloscope. Install the S-6 in the Sampling compartment and install the S-53 in the Pulse Generator compartment of the 7S12. The 7M11 50 Ω Delay Line requires no operating power, but can be installed in an unused compartment of 7504. Type 284 Pulse Generator is used in step 3, 4 & 5.

2. Set the controls as follows:

7504 Indicator Oscilloscope

A Intensity	CCW
B Intensity	CCW
Vertical Mode	Right
Horizontal Mode	A

7S12 with S-6 and S-53

(Two center compartments, the right vertical and the A horizontal compartments)

Time Distance dial	0
Multiplier	X.1
Time/Div	10 ns
Variable	Cal in
Fine (Zero Set)	Fully clockwise
Rep	pushed in
Scan	Midrange
Locate	pushed in
mV	pushed in
mV/Div	100
Variable	Cal in
DC Offset (& Fine)	Midrange

S-53

STABILITY	Fully Clockwise
LEVEL	Midrange
SLOPE	+

3. Turn on the Type 284, and the Oscilloscope power. After about five minutes warmup, advance the A Intensity until a free-running trace is observed. Center the trace with the 7S12 DC Offset control.

1. Check TRIG OUT (Front Panel) Amplitude and Duration

a. Connect the S-53 TRIG OUT signal through a BSM to BNC adapter, a 5X attenuator, a 42 inch BNC coaxial cable, and a BNC to GR adapter to 7M11 Input 1 connector. Connect the 7M11 Output 1 through a GR to BNC adapter, a 42 inch BNC coaxial cable, and a BNC to 3 mm adapter to the S-6 Loop Thru (lower) connector. Connect a 1 ns 3 mm coaxial line and a 50 Ω termination to the upper Loop Thru connector.

b. Turn the S-53 STABILITY control fully clockwise. Set the LEVEL control to about midrange, to observe the TRIG OUT signal on the CRT.

c. Check the TRIG OUT amplitude to be at least one volt positive-going (1 division or greater).

d. Change the Time/Div to 2 ns. Use the Time-Distance knob to position the the TRIG OUT display on screen. Check the TRIG OUT duration at the 50% amplitude point to be 3 ns within 2 ns.

2. Check TRIG OUT (Front Panel) Rise Rate

a. Change the Time/Div to 500 ps. Set the mV/Div to 50. Use the Time-Distance knob to position the rising portion of the TRIG OUT signal on the CRT.

b. Check any portion of the rise to be greater than 600 mV (1.2 divisions) in 1 ns. See Fig. 5-1.

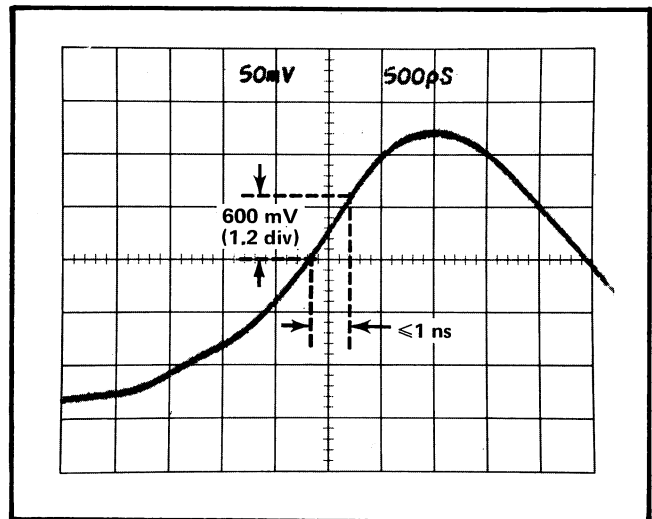

Fig. 5-1. Waveform of TRIG OUT leading edge showing Rise Rate. (2X attenuator in 7M11 and 5X attenuator in signal path for 500 mV/div.)

3. Check INPUT Signal to TRIG OUT Signal Delay Time

a. Disconnect the cables and connect as follows: Install a BNC tee connector onto the S-53 INPUT connector. To the TRIG OUT connector, install a BSM to BNC adapter and a 5X attenuator. Connect the Type 284 Pulse Output Signal through a GR to BNC adapter and a BNC coaxial cable to one arm of the tee connector. Connect the other arm of the tee connector through a 42 inch BNC coaxial cable, a BNC to GR adapter to Input 1 on the 7M11 50 Ω Delay Line. Connect the 7M11 Output 1 through a GR to BNC adapter, a 42 inch BNC coaxial cable, and a BNC to 3 mm adapter to the S-6 Loop Thru (lower) connector.

b. Set the mV/Div to 50. Set the Multiplier to X.1, and the Time/Div to 2 ns. Set the Time-Distance control for a dial reading of zero.

c. Set the S-53 LEVEL control for a stable display of the Type 284 Pulse Output leading edge (the S-53 Input signal). Change the Time-Distance knob to position the pulse leading edge to a reference point 1 division from the left side of the graticule.

d. Without moving the position, trigger controls, or other setup conditions; change the BNC cable connector from the BNC tee connector (the cable going to the 7M11) to the 5X attenuator installed with an adapter on the S-53 TRIG OUT connector.

e. Observe the TRIG OUT signal. Check the position of the TRIG OUT signal leading edge at the 50% amplitude point to be 15 ns or less from the reference point (Pulse Output leading edge) set in part c. See Fig. 5-2.

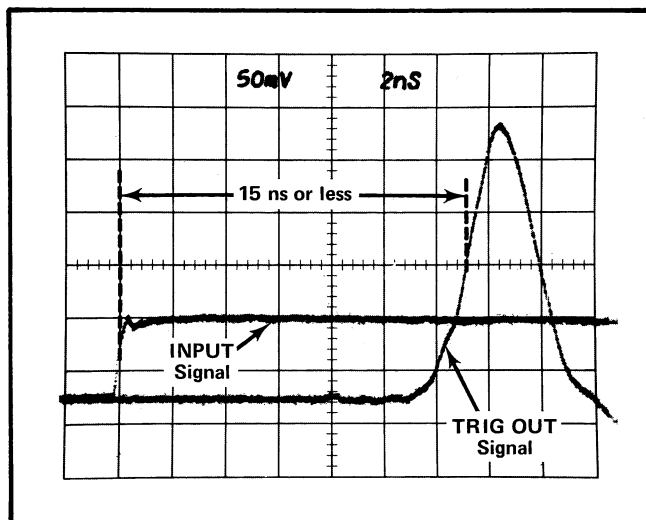

Fig. 5-2. Double exposure photo showing the INPUT signal to TRIG OUT delay time.

4. Check INPUT Signal to Trigger Out Signal Jitter

a. Disconnect the BNC cable connector from the 5X attenuator and connect it to the remaining arm of the tee connector. (This connects the input signal to the S-6 via the 7M11).

b. Set the Time-Distance control near zero to observe the Type 284 Pulse Output leading edge (S-53 INPUT Signal).

c. Set the mV/Div to 50, and set the mV/Div Variable control for a display amplitude of about 5 divisions. Then change the mV/Div to 10, and center the rising portion of the Pulse at the center of the graticule.

d. Change the Time-Div to 20 and Turn the Time-Distance knob to position the rising portion of the pulse to the center of the CRT.

e. Use 90% of the dots displayed in the rising portion of the signal to measure the jitter to be 15 ps or less. See Fig. 5-3.

5. Check Kickout at INPUT

a. Disconnect the cables from the Heads, remove the S-6 Sampling Head, and install a S-1 Sampling Head in its place.

b. Connect the S-53 TRIG OUT through a BSM to BNC adapter, a 5X attenuator, a 42 inch BNC coaxial cable, a BNC to GR adapter to Input 1 on the 7M11

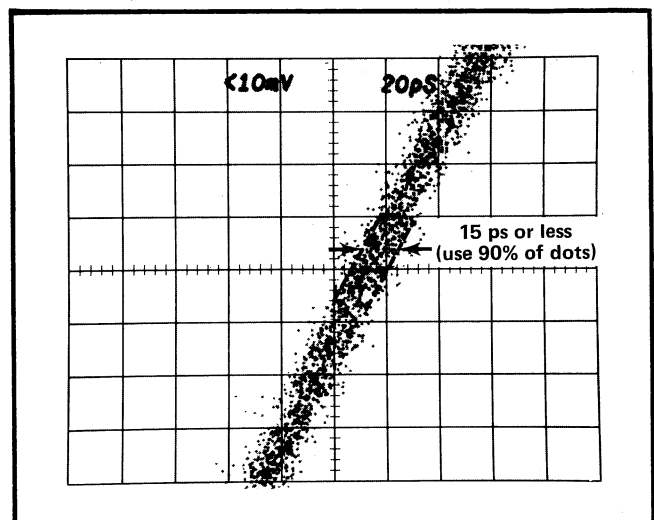

Fig. 5-3. Typical waveform to observe INPUT signal to Trigger Out signal jitter in step 4.

Performance Check/Calibration—S-53

Delay Line. Connect the 7M11 Output 1 through a 5 ns GR coaxial cable to the S-1 Input connector.

c. Change the following controls:

7S12	
Time Distance dial	0
Multiplier	X.1
Time/Div	10 ns
mV/Div	100
Variable	Cal in

d. Observe the TRIG OUT signal on the CRT screen and record its position horizontally on the graticule. See the typical displayed signal (Fig. 5-4 waveform A).

e. Disconnect the coaxial cable at the 5X attenuator and connect it to the S-53 INPUT connector. (This connects the INPUT through the Delay Line to the S-1 Input and maintains relative timing.)

f. Change the mV/Div to 2, and center the trace with the DC Offset control.

g. Turn the SCAN control counterclockwise for about a one second sweep to observe the Kickout signal. Adjust the S-53 LEVEL and STABILITY controls for maximum amplitude of the Kickout signal. See a typical waveform (Fig. 5-4 waveform B).

h. Observe the displayed Kickout signal to be less than 10 mV.

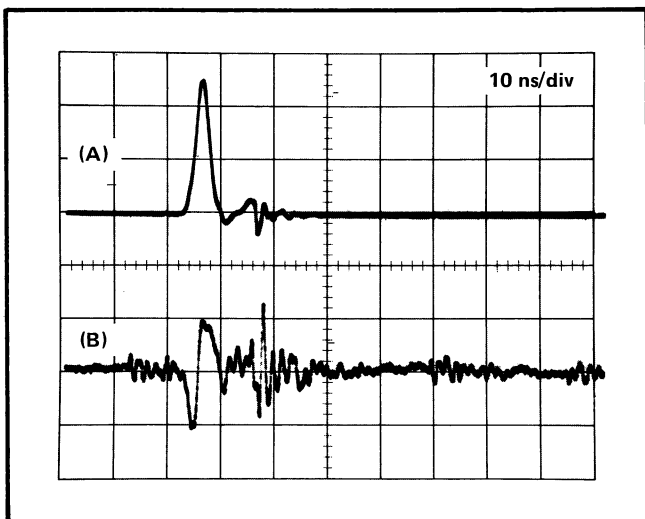

Fig. 5-4. Double exposure photo to show timing of kickout signal. (A) TRIG OUT signal; (B) Typical Kickout signal from the INPUT.

i. Disconnect the cables to the Heads, remove the S-1 Sampling Head, and install the S-6 Sampling Head in place of the S-1.

6. Check TRIG OUT Period

a. Set the S-53 STABILITY control fully clockwise, and the LEVEL control to midrange.

b. Connect a Test Oscilloscope (about 20 MHz bandwidth) 10X probe to the S-53 TRIG OUT connector (unterminated).

c. Trigger the Test Oscilloscope internally on a positive signal. Use 5 μ s/div sweep rate and about 5 V/Div including the probe.

d. Check the TRIG OUT Period to be 27 μ s within 2.5 μ s.

7. Check INPUT Signal and Sensitivity

a. Disconnect the cables and connect as follows: Connect 100 ns 1 volt square wave signal from the Type 284 through a Variable attenuator, a GR to BNC adapter to a BNC tee connector. Connect one arm of the tee connector through a 42 inch BNC coaxial cable to the S-53 INPUT connector. Connect the other arm of the tee connector through a 42 inch BNC coaxial cable, and a BNC to 3 mm adapter to the S-6 Loop Thru (lower) connector.

b. Set the Multiplier to X.1. Set the Time/Div to 10 ns, and the mV/Div to 200. Set the Variable attenuator in the signal path to clockwise (minimum attenuation).

c. Set the S-53 STABILITY control fully counterclockwise, and set the LEVEL control for a stable display of the 100 ns period square wave. Check that the LEVEL control can be set for a stable display with the SLOPE switch in either + or -.

d. Change the Type 284 Square Wave Amplitude to 100 mV. Change the Variable attenuator in the signal path to reduce the display to about 15 mV (set the S-53 LEVEL control to maintain a triggered display). Check that the display can be triggered with the SLOPE switch in either + or -.

e. Change the Type 284 Period switch to 10 ns. Use both the S-53 STABILITY and LEVEL controls for a stable display of the 10 ns period sine wave display.

Further adjust the Variable control in the signal path for about a 15 mV amplitude display. Check that a stable display can be obtained with the STABILITY AND LEVEL controls.

f. Change the Type 284 Period switch to 1 ns. Use both the STABILITY and the LEVEL controls to obtain a stable display.

CALIBRATION PROCEDURE

Introduction

The Calibration Procedure contains all the adjustments required in the instrument. Troubleshooting information is contained in the Maintenance Section and in the Diagram Section.

Preliminary Procedure

1. Assemble the equipment as follows: Install the 7S12 in the center two compartments of the 7504 Oscilloscope. Install the S-6 in the Sampling compartment, and install the Sampling Head Extender into the Pulse Generator compartment of the 7S12. A Type 284 Pulse Generator is used.

2. Remove the S-53 from its housing (see the Maintenance Section), and install it onto the Sampling Head Extender.

3. Set the controls as follows:

7504 Indicator Oscilloscope

A Intensity	CCW
B Intensity	CCW
Vertical Mode	Right
Horizontal Mode	A

7S12 with S-6 and (S-53 on Extender)

(Two center compartments, the right vertical and the A horizontal compartments)

Time Distance dial	0
Multiplier	X10
Time/Div	1 μ s
Variable	Cal in
Fine (Zero Set)	Fully clockwise
Rep	pushed in
Scan	9 o'clock
Locate	pushed in
mV	pushed in
mV/Div	100
Variable	Cal in
DC Offset (& Fine)	Midrange

S-53

STABILITY	Fully Counterclockwise
SLOPE	+
LEVEL	Midrange (set in step 1)

4. Turn on the Type 284, and the Oscilloscope power. After about five minutes warmup, advance the A intensity until a free-running trace is observed. Center the trace on the CRT with the 7S12 DC Offset control.

1. Adjust Trig Zero (R25) and Stability Zero (R30)

a. Preset R30 fully clockwise (minimum resistance). If the Arm or Start Tunnel Diode circuits have been changed, set R82 and R92 to midrange.

b. With no input signal, use a Test Oscilloscope with a 1X probe or a sensitive voltmeter connected to Q12 base, and set the LEVEL control for a Q12 base voltage of about -6 mV. Then remove the probe.

c. Adjust R25 until the oscilloscope trace shows some noise, indicating that the trace is triggered by the S-53. Further set R25 to the center of this indicated triggered range.

d. Turn R30 counterclockwise until the indicated triggered trace stops. Then adjust R25 to restore the indicated triggered trace. Repeat R30 and R25 adjustments for a maximum counterclockwise rotation of R30 that still maintains the indicated triggered trace.

e. Connect the Type 284 100 ns square wave output signal through a variable attenuator, GR to BNC adapter to a BNC tee connector. Connect one output of the tee connector through a BNC coaxial cable, BNC to 3 mm adapter to the S-6 Feed Thru (lower) connector. Connect the other output of the tee connector through a BNC coaxial cable to the S-53 INPUT connector.

f. Set the Variable attenuator in the signal path for a 15 mV signal display on the CRT (15 mV input signal). Set the mV/Div to 10.

g. Using the LEVEL control obtain a stable display. Set the Variable attenuator to reduce the input signal to about 10 mV.

If the LEVEL control can be set for a stable display, further adjust R30 slightly counterclockwise until the display is untriggered (repeat if necessary). Then increase the input signal to 15 mV and check for a triggered display. If these conditions are not met, repeat the step.

2. Adjust Arm and Start T.D. Bias (R82), (R92)

a. Disconnect the connecting cables and reconnect as follows: Connect Type 284 Pulse Output through GR to BNC adapter to a BNC tee connector. Connect one output of the tee connector through a 42 inch BNC coaxial cable and a BNC to GR connector to Input 1 of the 7M11 50 Ω Delay Line. Connect 7M11 Output 1 through a GR to BNC adapter, a 42 inch BNC coaxial cable, and a BNC to 3 mm adapter to S-6 Loop Thru (lower connector). Connect the other output from the tee connector through an 18 inch BNC coaxial cable to S-53 INPUT connector.

b. Push in the $m\rho$ button. Set the $m\rho/Div$ to 100. Set the Multiplier to X.1, and the Time/Div to 2 ns. Set the S-53 LEVEL control for a stable trace. Adjust the $m\rho/Div$ Variable for about a 5 division display. Center the display with the DC Offset control.

c. Change the $m\rho/Div$ to 10. Change the Time/Div to 50 ps and change the Time-Distance knob to position the center portion of the display to the center of the CRT.

d. Adjust R82 and R92 for minimum jitter. The display may show a jump to the left before the minimum jitter point during the adjustment.

REPLACEABLE ELECTRICAL PARTS

PARTS ORDERING INFORMATION

Replacement parts are available from or through your local Tektronix, Inc. Field Office or representative.

Changes to Tektronix instruments are sometimes made to accommodate improved components as they become available, and to give you the benefit of the latest circuit improvements developed in our engineering department. It is therefore important, when ordering parts, to include the following information in your order: Part number, instrument type or number, serial number, and modification number if applicable.

If a part you have ordered has been replaced with a new or improved part, your local Tektronix, Inc. Field Office or representative will contact you concerning any change in part number.

Change information, if any, is located at the rear of this manual.

SPECIAL NOTES AND SYMBOLS

X000 Part first added at this serial number
00X Part removed after this serial number

ITEM NAME

In the Parts List, an Item Name is separated from the description by a colon (:). Because of space limitations, an Item Name may sometimes appear as incomplete. For further Item Name identification, the U.S. Federal Cataloging Handbook H6-1 can be utilized where possible.

ABBREVIATIONS

ACTR	ACTUATOR	PLSTC	PLASTIC
ASSY	ASSEMBLY	QTZ	QUARTZ
CAP	CAPACITOR	RECP	RECEPTACLE
CER	CERAMIC	RES	RESISTOR
CKT	CIRCUIT	RF	RADIO FREQUENCY
COMP	COMPOSITION	SEL	SELECTED
CONN	CONNECTOR	SEMICOND	SEMICONDUCTOR
ELCTLT	ELECTROLYTIC	SENS	SENSITIVE
ELEC	ELECTRICAL	VAR	VARIABLE
INCAND	INCANDESCENT	WW	WIREWOUND
LED	LIGHT EMITTING DIODE	XFMR	TRANSFORMER
NONWIR	NON WIREWOUND	XTAL	CRYSTAL

CROSS INDEX - MFR. CODE NUMBER TO MANUFACTURER

Mfr. Code	Manufacturer	Address	City, State, Zip Code
01121	ALLEN-BRADLEY CO	1201 SOUTH 2ND ST	MILWAUKEE WI 53204
02735	RCA CORP SOLID STATE DIVISION	ROUTE 202	SOMERVILLE NJ 08876
03508	GENERAL ELECTRIC CO SEMI-CONDUCTOR PRODUCTS DEPT	W GENESEE ST	AUBURN NY 13021
04222	AVX CERAMICS DIV OF AVX CORP	19TH AVE SOUTH P O BOX 867	MYRTLE BEACH SC 29577
04713	MOTOROLA INC SEMICONDUCTOR GROUP	5005 E MCDOWELL RD	PHOENIX AZ 85008
05397	UNION CARBIDE CORP MATERIALS SYSTEMS DIV	11901 MADISON AVE	CLEVELAND OH 44101
07716	TRW INC TRW ELECTRONICS COMPONENTS TRW IRC FIXED RESISTORS/BURLINGTON	2850 MT PLEASANT AVE	BURLINGTON IA 52601
09353	C AND K COMPONENTS INC	15 RIVERDALE AVE	NEWTON MA 02158
14193	CAL-R INC	1601 OLYMPIC BLVD	SANTA MONICA CA 90404
14552	MICRO/SEMICONDUCTOR CORP	2830 S FAIRVIEW ST	SANTA ANA CA 92704
19701	MEPCO/ELECTRA INC A NORTH AMERICAN PHILIPS CO	P O BOX 760	MINERAL WELLS TX 76067
23223	CTS MICROELECTRONICS INC	1201 CUMBERLAND AVE P O BOX 1278	WEST LAFAYETTE IN 47902
24931	SPECIALTY CONNECTOR CO INC	2620 ENDRESS PLACE P O BOX D	GREENWOOD IN 46142
32997	BOURNS INC TRIMPOT DIV	1200 COLUMBIA AVE	RIVERSIDE CA 92507
54583	TDK ELECTRONICS CORP	755 EASTGATE BLVD	GARDEN CITY NY 11530
57668	ROHM CORP	16931 MILLIKEN AVE	IRVINE CA 92713
59660	TUSONIX INC	2155 N FORBES BLVD	TUCSON, ARIZONA 85705
72982	ERIE TECHNOLOGICAL PRODUCTS INC	645 W 11TH ST	ERIE PA 16512
75042	INTERNATIONAL RESISTIVE CO INC	401 N BROAD ST	PHILADELPHIA PA 19108
80009	TEKTRONIX INC	4900 S W GRIFFITH DR P O BOX 500	BEAVERTON OR 97077
91418	RADIO MATERIALS CORP	4242 BYRN MAWR AVE W	CHICAGO IL 60646
98291	SEAELECTRO CORP	225 HOYT	MAMARONECK NY 10544
TK0961	NEC ELECTRONICS USA INC	401 ELLIS ST	MOUNTAIN VIEW CA 94043

Component No.	Tektronix Part No.	Serial/Assembly No. Effective	Discnt	Name & Description	Mfr. Code	Mfr. Part No.
A1	670-1460-00	B010100	B050689	CIRCUIT BD ASSY:TRIGGER	80009	670-1460-00
A1	670-1460-01	B050690	B152019	CIRCUIT BD ASSY:TRIGGER	80009	670-1460-01
A1	670-1460-02	B152020		CIRCUIT BD ASSY:TRIGGER	80009	670-1460-02
A1C3	283-0121-00			CAP,FXD,CER DI:1000PF,20%,200V	91418	5P102M2011958
A1C5	283-0121-00			CAP,FXD,CER DI:1000PF,20%,200V	91418	5P102M2011958
A1C10	283-0140-00	B010100	B019999	CAP,FXD,CER DI:4.7PF,+/-0.25PF,50V	72982	8101E003A479C
A1C10	283-0141-00	B020000		CAP,FXD,CER DI:200PF,10%,600V	14193	PD-0321-201K
A1C19	283-0121-00			CAP,FXD,CER DI:1000PF,20%,200V	91418	5P102M2011958
A1C21	283-0121-00			CAP,FXD,CER DI:1000PF,20%,200V	91418	5P102M2011958
A1C35	283-0121-00			CAP,FXD,CER DI:1000PF,20%,200V	91418	5P102M2011958
A1C41	283-0032-00			CAP,FXD,CER DI:470PF,5%,500V	59660	831-000-Z5E0471J
A1C49	283-0159-00			CAP,FXD,CER DI:18PF,5%,50V	04222	SR155A180JAA
A1C50	283-0186-00			CAP,FXD,CER DI:27PF,5%,50V	04222	SR155A 270JAA
A1C101	283-0198-00			CAP,FXD,CER DI:0.22UF,20%,50V	05397	C330C224M5U1CA
A1C103	283-0198-00			CAP,FXD,CER DI:0.22UF,20%,50V	05397	C330C224M5U1CA
A1CR6	152-0141-02			SEMICON DVC,DI:SW,SI,30V,150MA,30V,DO-35	03508	DA2527 (1N4152)
A1CR8	152-0141-02			SEMICON DVC,DI:SW,SI,30V,150MA,30V,DO-35	03508	DA2527 (1N4152)
A1CR23	152-0141-02			SEMICON DVC,DI:SW,SI,30V,150MA,30V,DO-35	03508	DA2527 (1N4152)
A1CR25	152-0177-00			SEMICON DVC,DI:SELECTED	80009	152-0177-00
A1J50	131-0582-00			CONN,RCPT,ELEC:SNAP-ON,FEMALE,MODIFIED	98291	52-052-0049
A1Q10	153-0594-00			SEMICON DVC SE:MATCHED PAIR	80009	153-0594-00
A1Q12	-----			(PART OF Q10)		
A1Q20	151-0294-00	B010100	B152019	TRANSISTOR:P,NP,SI,U-43	04713	SMT1014
A1Q20	151-0362-00	B152020		TRANSISTOR:P,NP,SI,U-43	04713	SMT1105
A1Q22	151-0294-00	B010100	B152019	TRANSISTOR:P,NP,SI,U-43	04713	SMT1014
A1Q22	151-0362-00	B152020		TRANSISTOR:P,NP,SI,U-43	04713	SMT1105
A1Q30	151-0190-01			TRANSISTOR:NPN,SI,TO-92	80009	151-0190-01
A1Q40	151-0188-00			TRANSISTOR:P,NP,SI,TO-92	80009	151-0188-00
A1Q50	151-0269-00	B010100	B039999	TRANSISTOR:NPN,SI,TO-92	TK0961	41632BD
A1Q50	151-0441-01	B040000		TRANSISTOR:NPN,SI	80009	151-0441-01
A1R2	317-0510-00			RES,FXD,CMPSN:51 OHM,5%,0.125W	01121	BB5105
A1R3	321-0228-00			RES,FXD,FILM:2.32K OHM,1%,0.125W,TC=TO	19701	5043ED2K32F
A1R4	307-0241-00			RES,FXD,CMPSN:100 OHM,10%,0.075W	23223	100A5L
A1R5	323-0191-00			RES,FXD,FILM:953 OHM,1%,0.5W,TC=TO	75042	CECT0-9530F
A1R8	317-0201-00			RES,FXD,CMPSN:200 OHM,5%,0.125W	01121	BB2015
A1R10	317-0430-00	B010100	B019999	RES,FXD,CMPSN:43 OHM,5%,0.125W	01121	BB4305
A1R10	317-0101-00	B020000		RES,FXD,CMPSN:100 OHM,5%,0.125W	01121	BB1015
A1R12	317-0510-00			RES,FXD,CMPSN:51 OHM,5%,0.125W	01121	BB5105
A1R13	317-0822-00			RES,FXD,CMPSN:8.2K OHM,5%,0.125W	01121	BB8225
A1R16	317-0471-00			RES,FXD,CMPSN:470 OHM,5%,0.125W	01121	BB4715
A1R17	321-0228-00			RES,FXD,FILM:2.32K OHM,1%,0.125W,TC=TO	19701	5043ED2K32F
A1R18	307-0241-00			RES,FXD,CMPSN:100 OHM,10%,0.075W	23223	100A5L
A1R19	323-0191-00			RES,FXD,FILM:953 OHM,1%,0.5W,TC=TO	75042	CECT0-9530F
A1R20	317-0101-00			RES,FXD,CMPSN:100 OHM,5%,0.125W	01121	BB1015
A1R21	317-0102-00			RES,FXD,CMPSN:1K OHM,5%,0.125W	01121	BB1025
A1R22	317-0101-00			RES,FXD,CMPSN:100 OHM,5%,0.125W	01121	BB1015
A1R24	315-0102-00			RES,FXD,FILM:1K OHM,5%,0.25W	57668	NTR25JE01K0
A1R25	311-0622-00			RES,VAR,NONNW:TRMR,100 OHM,0.5W	32997	3329H-L58-101
A1R26	317-0680-00			RES,FXD,CMPSN:68 OHM,5%,0.125W	01121	BB6805
A1R28	317-0101-00			RES,FXD,CMPSN:100 OHM,5%,0.125W	01121	BB1015
A1R29	317-0362-00			RES,FXD,CMPSN:3.6K OHM,5%,0.125W	01121	BB3625
A1R30	311-0635-00			RES,VAR,NONNW:TRMR,1K OHM,0.5W	32997	3329H-G48-102
A1R32	317-0202-00			RES,FXD,CMPSN:2K OHM,5%,0.125W	01121	BB2025
A1R33	317-0103-00			RES,FXD,CMPSN:10K OHM,5%,0.125W	01121	BB1035
A1R35	315-0132-00			RES,FXD,FILM:1.3K OHM,5%,0.25W	57668	NTR25J-E01K3
A1R41	317-0752-00			RES,FXD,CMPSN:7.5K OHM,5%,0.125W	01121	BB7525
A1R43	315-0132-00			RES,FXD,FILM:1.3K OHM,5%,0.25W	57668	NTR25J-E01K3
A1R49	317-0430-00	B050690		RES,FXD,CMPSN:43 OHM,5%,0.125W	01121	BB4305

Replaceable Electrical Parts - S-53

Component No.	Tektronix Part No.	Serial/Assembly No. Effective	Dscort	Name & Description	Mfr. Code	Mfr. Part No.
A1R50	317-0393-00			RES, FXD, CMPSN:39K OHM, 5%, 0.125W	01121	BB3935
A1VR21	152-0279-00			SEMICON DVC, DI:ZEN, SI, 5.1V, 5%, 0.4W, DO-7	14552	TD3810989

Component No.	Tektronix Part No.	Serial/Assembly No. Effective	Discont	Name & Description	Mfr. Code	Mfr. Part No.
A2	670-1461-00	B010100	B050689	CIRCUIT BD ASSY:T D DRIVER	80009	670-1461-00
A2	670-1461-01	B050690		CIRCUIT BD ASSY:T D DRIVER	80009	670-1461-01
A2C57	283-0186-00			CAP, FXD, CER DI:27PF, 5%, 50V	04222	SR155A 270JAA
A2C58	283-0111-00			CAP, FXD, CER DI:0.1UF, 20%, 50V	05397	C330C104M5U1CA
A2C60	283-0060-00			CAP, FXD, CER DI:100PF, 5%, 200V	59660	855-535U2J101J
A2C61	283-0175-00			CAP, FXD, CER DI:10PF, 5%, 200V	05397	C312C10002G5CA 8
A2C62	283-0175-00			CAP, FXD, CER DI:10PF, 5%, 200V	05397	C312C10002G5CA 8
A2C65	283-0175-00			CAP, FXD, CER DI:10PF, 5%, 200V	05397	C312C10002G5CA 8
A2C70	283-0142-00	B010100	B019999	CAP, FXD, CER DI:0.0027UF, 5%, 200V	54583	CK45YE2D272J-A
A2C70	283-0051-00	B020000		CAP, FXD, CER DI:0.0033UF, 5%, 100V	04222	SR301A332JAA
A2C85	283-0065-00			CAP, FXD, CER DI:0.001UF, 5%, 100V	59660	0835-591Y5E0102J
A2CR51	152-0141-02			SEMICON DVC, DI:SW, SI, 30V, 150MA, 30V, DO-35	03508	DA2527 (1N4152)
A2CR61	152-0141-02			SEMICON DVC, DI:SW, SI, 30V, 150MA, 30V, DO-35	03508	DA2527 (1N4152)
A2CR65	152-0141-02			SEMICON DVC, DI:SW, SI, 30V, 150MA, 30V, DO-35	03508	DA2527 (1N4152)
A2CR67	152-0141-02			SEMICON DVC, DI:SW, SI, 30V, 150MA, 30V, DO-35	03508	DA2527 (1N4152)
A2CR68	152-0141-02			SEMICON DVC, DI:SW, SI, 30V, 150MA, 30V, DO-35	03508	DA2527 (1N4152)
A2CR70	152-0141-02			SEMICON DVC, DI:SW, SI, 30V, 150MA, 30V, DO-35	03508	DA2527 (1N4152)
A2CR82	152-0140-01			SEMICON DVC, DI:TNL, GE, 10MA, 8PF, DO-17	03508	SMTD995
A2CR92	152-0177-00			SEMICON DVC, DI:SELECTED	80009	152-0177-00
A2P50	131-0391-00			CONN, RCPT, ELEC: SNAP-ON, MALE	24931	32JR105-1
A2P60	175-1264-00			CABLE ASSY, RF: 50 OHM COAX, 1.5 L	80009	175-1264-00
A2Q55	151-0269-00	B010100	B039999	TRANSISTOR: NPN, SI, TO-92	TK0961	41632B0
A2Q55	151-0441-01	B040000		TRANSISTOR: NPN, SI	80009	151-0441-01
A2Q60	151-0271-00			TRANSISTOR: PNP, SI, TO-92	04713	SPS8236
A2R51	317-0430-00			RES, FXD, CMPSN: 43 OHM, 5%, 0.125W	01121	BB4305
A2R52	317-0430-00			RES, FXD, CMPSN: 43 OHM, 5%, 0.125W	01121	BB4305
A2R53	317-0181-00			RES, FXD, CMPSN: 180 OHM, 5%, 0.125W	01121	BB1815
A2R54	317-0103-00			RES, FXD, CMPSN: 10K OHM, 5%, 0.125W	01121	BB1035
A2R55	317-0104-00			RES, FXD, CMPSN: 100K OHM, 5%, 0.125W	01121	BB1045
A2R57	317-0103-00			RES, FXD, CMPSN: 10K OHM, 5%, 0.125W	01121	BB1035
A2R58	317-0102-00			RES, FXD, CMPSN: 1K OHM, 5%, 0.125W	01121	BB1025
A2R60	317-0750-00			RES, FXD, CMPSN: 75 OHM, 5%, 0.125W	01121	BB7505
A2R61	317-0512-00			RES, FXD, CMPSN: 5.1K OHM, 5%, 0.125W	01121	BB5125
A2R62	317-0103-00			RES, FXD, CMPSN: 10K OHM, 5%, 0.125W	01121	BB1035
A2R63	317-0301-00			RES, FXD, CMPSN: 300 OHM, 5%, 0.125W	01121	BB3015
A2R65	317-0512-00			RES, FXD, CMPSN: 5.1K OHM, 5%, 0.125W	01121	BB5125
A2R67	317-0101-00			RES, FXD, CMPSN: 100 OHM, 5%, 0.125W	01121	BB1015
A2R68	317-0332-00	B010100	B050689	RES, FXD, CMPSN: 3.3K OHM, 5%, 0.125W	01121	BB3325
A2R68	317-0392-00	B050690		RES, FXD, CMPSN: 3.9K OHM, 5%, 0.125W	01121	BB3925
A2R70	317-0153-00	B010100	B050689	RES, FXD, CMPSN: 15K OHM, 5%, 0.125W	01121	BB1535
A2R70	317-0123-00	B050690		RES, FXD, CMPSN: 12K OHM, 5%, 0.125W	01121	BB1235
A2R73	317-0434-00			RES, FXD, CMPSN: 430K OHM, 5%, 0.125W	01121	BB4345
A2R75	321-0306-00			RES, FXD, FILM: 15.0K OHM, 1%, 0.125W, TC=TO	19701	5033ED15J00F
A2R76	317-0622-00			RES, FXD, CMPSN: 6.2K OHM, 5%, 0.125W	01121	BB6225
A2R77	321-0297-00			RES, FXD, FILM: 12.1K OHM, 1%, 0.125W, TC=TO	07716	CEAD12101F
A2R81	317-0103-00			RES, FXD, CMPSN: 10K OHM, 5%, 0.125W	01121	BB1035
A2R82	311-0634-00			RES, VAR, NONW: TRMR, 500 OHM, 0.5W	32997	3329H-L58-501
A2R84	315-0112-00			RES, FXD, FILM: 1.1K OHM, 5%, 0.25W	19701	5043CX1K100J
A2R85	317-0201-00			RES, FXD, CMPSN: 200 OHM, 5%, 0.125W	01121	BB2015
A2R91	317-0103-00			RES, FXD, CMPSN: 10K OHM, 5%, 0.125W	01121	BB1035
A2R92	311-0634-00			RES, VAR, NONW: TRMR, 500 OHM, 0.5W	32997	3329H-L58-501
A2R94	315-0162-00			RES, FXD, FILM: 1.6K OHM, 5%, 0.25W	19701	5043CX1K600J
A2R95	317-0101-00			RES, FXD, CMPSN: 100 OHM, 5%, 0.125W	01121	BB1015
A2R97	317-0470-00			RES, FXD, CMPSN: 47 OHM, 5%, 0.125W	01121	BB4705
A2U80	156-0048-00			MICROCKT, LINEAR: 5 XSTR ARRAY	02735	CA3046
A2VR67	152-0280-00			SEMICON DVC, DI:ZEN, SI, 6.2V, 5%, 0.4W, DO-7	04713	1N753A

Replaceable Electrical Parts - S-53

Component No.	Tektronix	Serial/Assembly No.		Name & Description	Mfr.	Mfr. Part No.
	Part No.	Effective	Discont		Code	
J10	131-0126-00			CONN, RCPT, ELEC: BNC, FEMALE	24931	28JR205-2
J60	175-1039-00			CABLE ASSY, RF: 50 OHM COAX, 3.5 L	80009	175-1039-00
R15	311-0546-00			RES, VAR, NONW: TRMR, 10K OHM, 0.5W	01121	W-8154A
R40	311-0091-00			RES, VAR, NONW: PNL, 1K OHM, 0.5W	01121	W-3083E
S10	260-0613-00			SWITCH, TOGGLE: SPDT, 5A, 115VAC, ON-ON	09353	7101SHZQI

SECTION 7

DIAGRAMS AND CIRCUIT BOARD ILLUSTRATIONS

Symbols and Reference Designators

Electrical components shown on the diagrams are in the following units unless noted otherwise:

- Capacitors = Values one or greater are in picofarads (pF).
Values less than one are in microfarads (μF).
- Resistors = Ohms (Ω).

Graphic symbols and class designation letters are based on ANSI Standard Y32.2-1975.

Logic symbology is based on ANSI Y32.14-1973 in terms of positive logic. Logic symbols depict the logic function performed and may differ from the manufacturer's data.

The overline on a signal name indicates that the signal performs its intended function when it goes to the low state.

Abbreviations are based on ANSI Y1.1-1972.

Other ANSI standards that are used in the preparation of diagrams by Tektronix, Inc. are:

- Y14.15, 1966 Drafting Practices.
- Y14.2, 1973 Line Conventions and Lettering.
- Y10.5, 1968 Letter Symbols for Quantities Used in Electrical Science and Electrical Engineering.

The following prefix letters are used as reference designators to identify components or assemblies on the diagrams.

A	Assembly, separable or repairable (circuit board, etc)	H	Heat dissipating device (heat sink, heat radiator, etc)	S	Switch or contactor
AT	Attenuator, fixed or variable	HR	Heater	T	Transformer
B	Motor	HY	Hybrid circuit	TC	Thermocouple
BT	Battery	J	Connector, stationary portion	TP	Test point
C	Capacitor, fixed or variable	K	Relay	U	Assembly, inseparable or non-repairable (integrated circuit, etc.)
CB	Circuit breaker	L	Inductor, fixed or variable	V	Electron tube
CR	Diode, signal or rectifier	M	Meter	VR	Voltage regulator (zener diode, etc.)
DL	Delay line	P	Connector, movable portion	W	Wirestrap or cable
DS	Indicating device (lamp)	Q	Transistor or silicon-controlled rectifier	Y	Crystal
E	Spark Gap, Ferrite bead	R	Resistor, fixed or variable	Z	Phase shifter
F	Fuse	RT	Thermistor		
FL	Filter				

The following special symbols may appear on the diagrams:

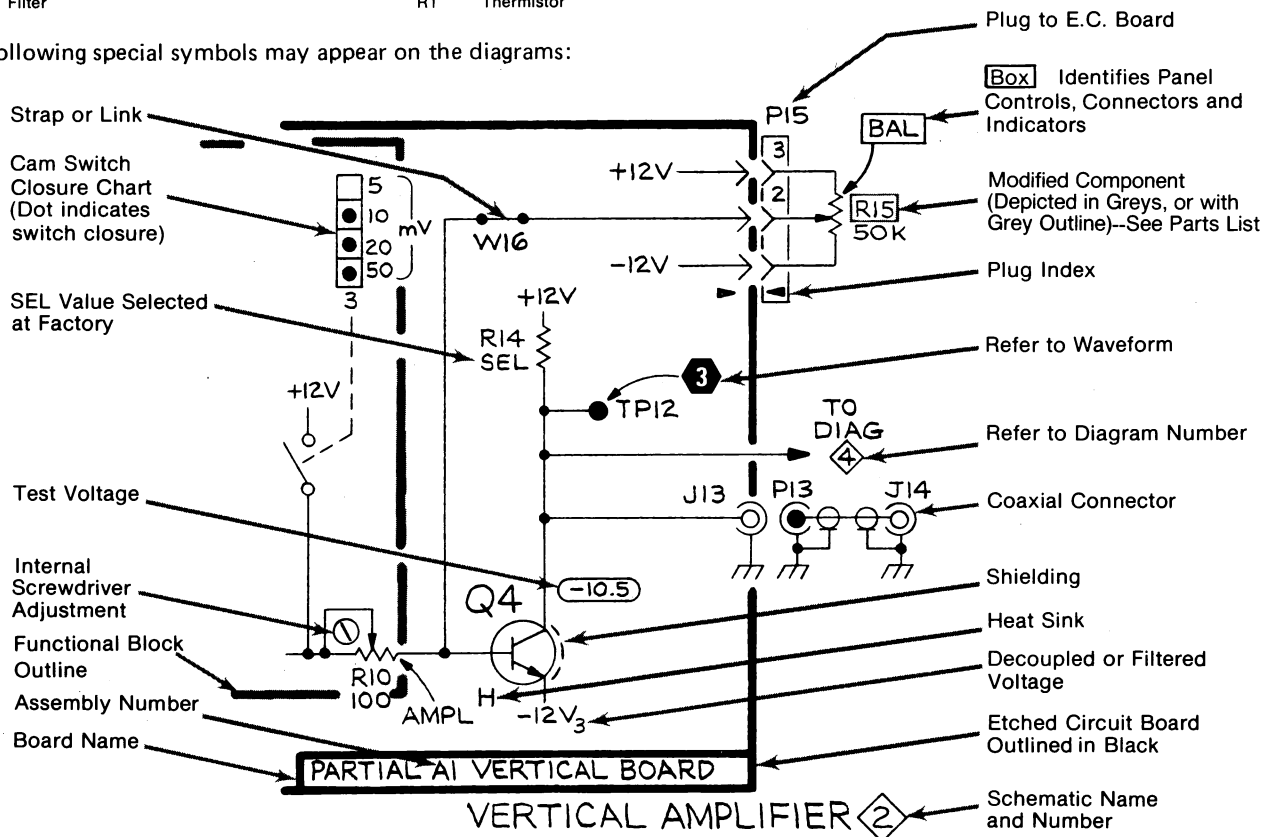

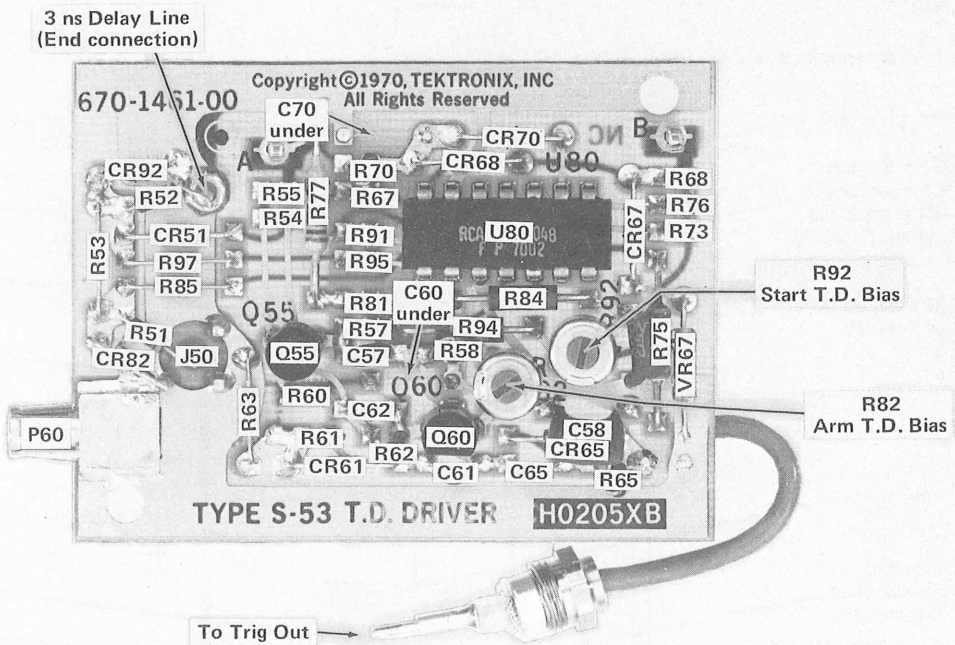
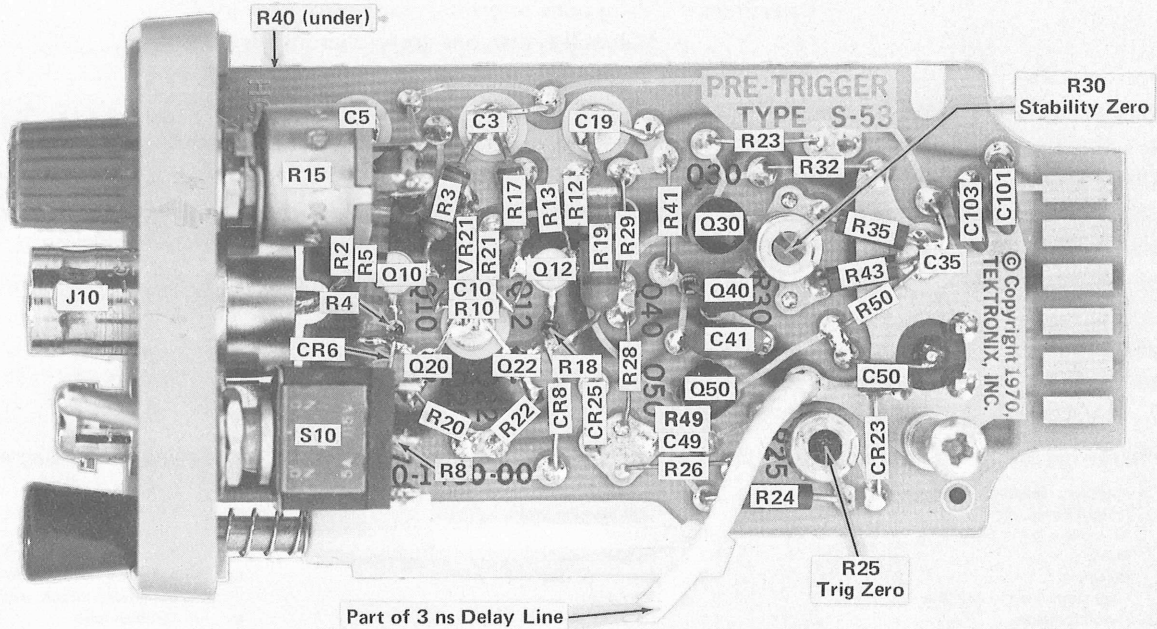

Troubleshooting Conditions

Power is obtained from Type 285 Power Supply, or sampling head compartment. Use a sampling Head Extender so that the Type S-53 case can be removed. Trigger the Test Oscilloscope from the TRIG OUT pulse to show time relationship. 100 mV—100 ns square wave input from Type 284 to S-53 Input.

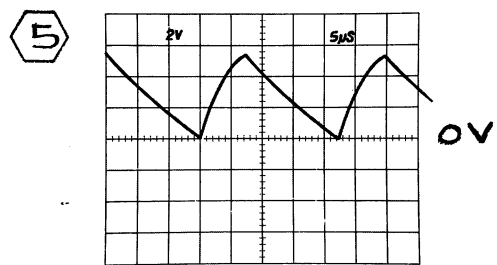
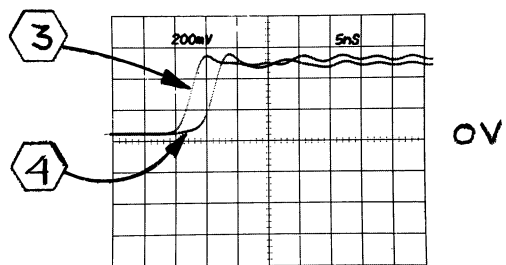
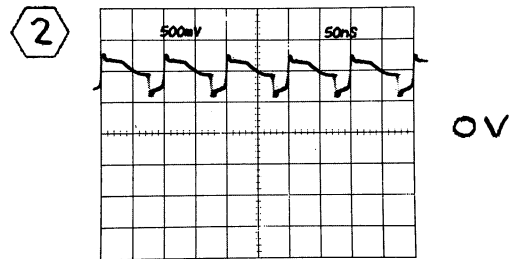
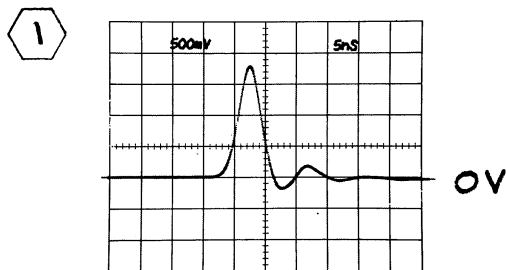

Double exposure photograph to show about 3 ns time difference.

Troubleshooting waveforms were obtained with 7A16, 7B50, and 7503. Signals for waveforms (No. 1) were coaxially connected and 50 Ω terminated, and all others were connected with P6053 10X probe with a short ground lead. DC coupling was used for all waveforms.

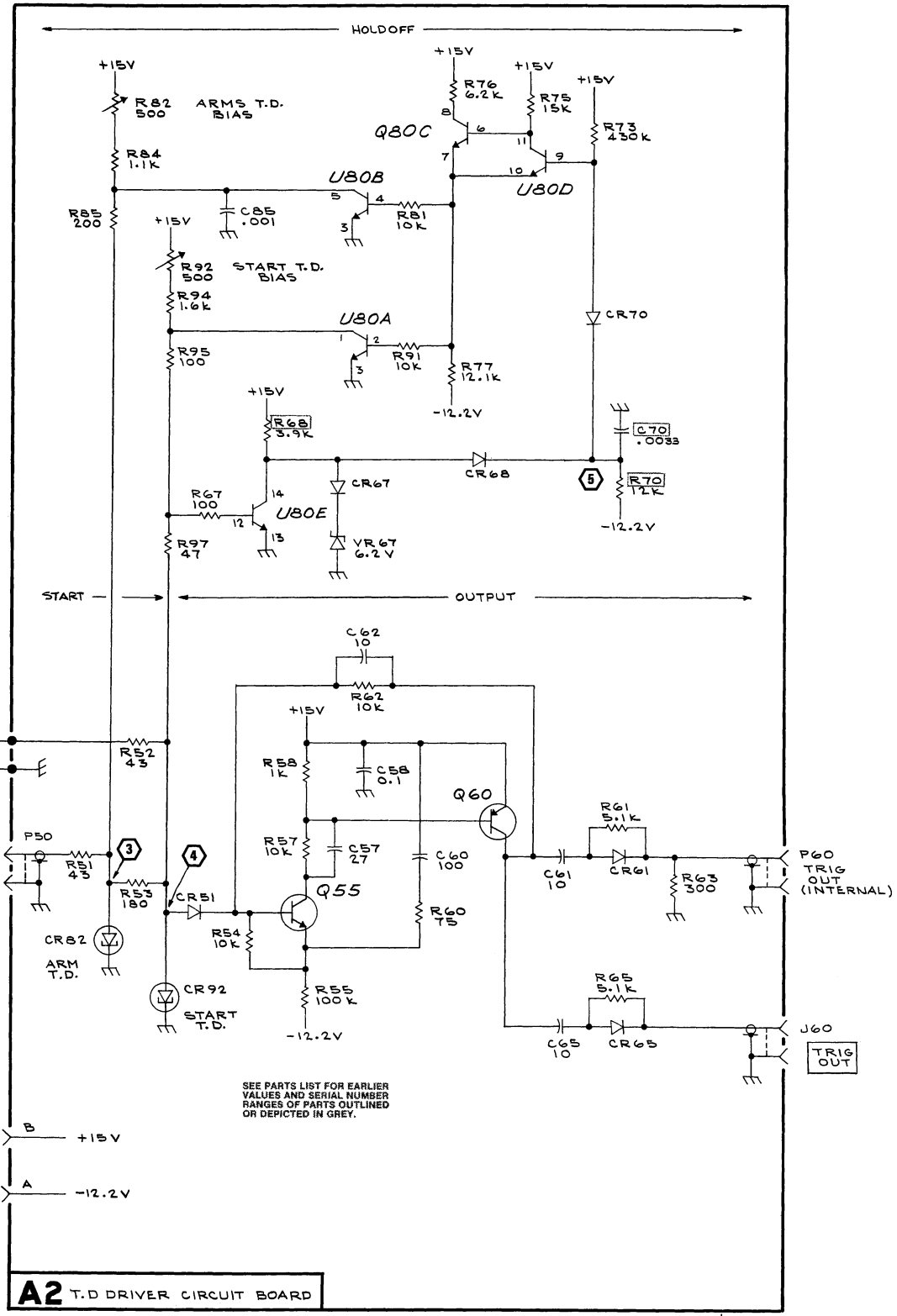
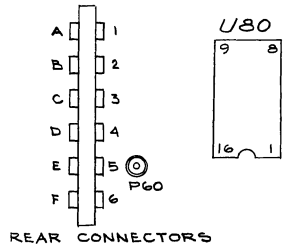
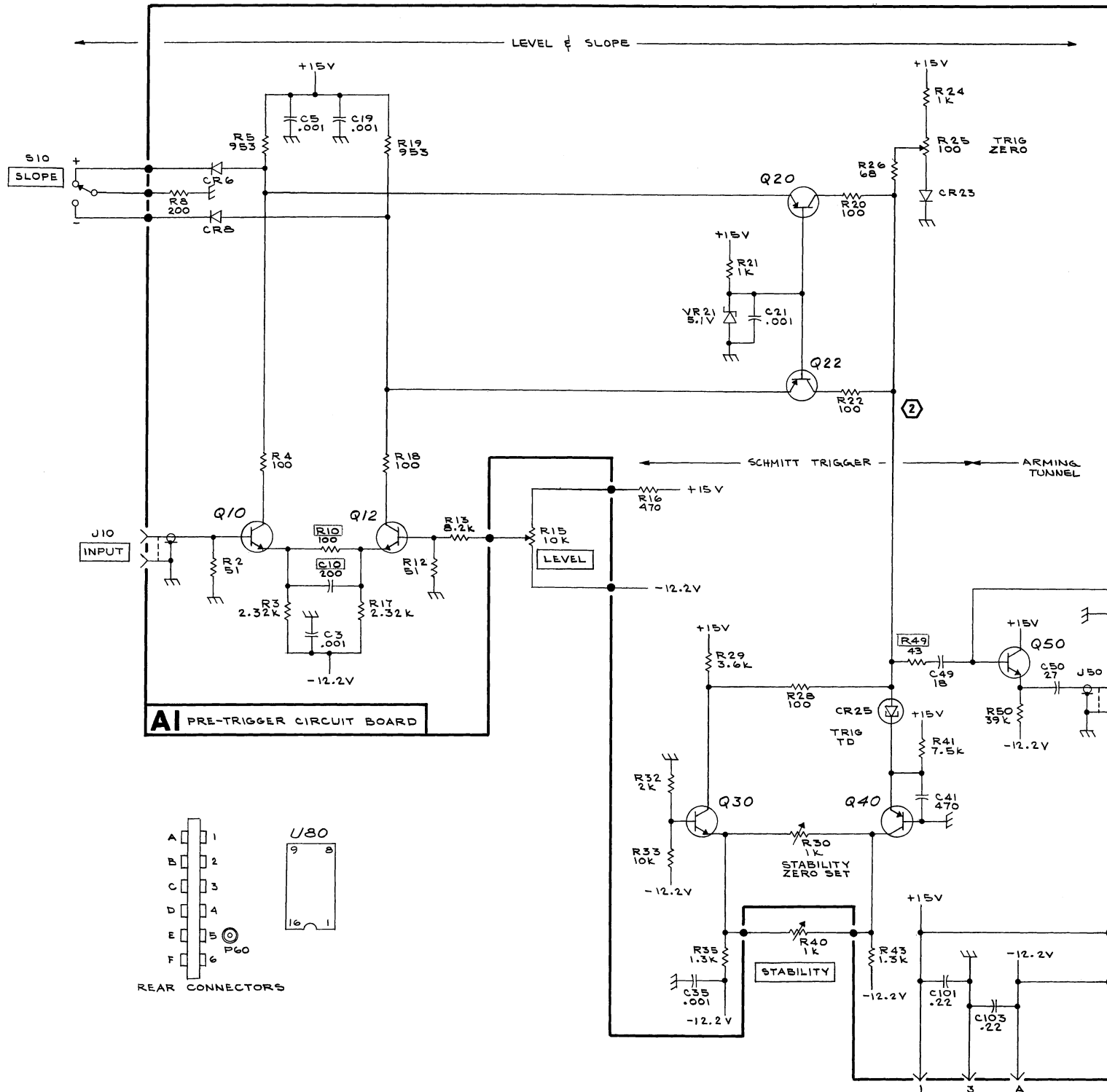

SEE PARTS LIST FOR EARLIER VALUES AND SERIAL NUMBER RANGES OF PARTS OUTLINED OR DEPICTED IN GREY.

REPLACEABLE MECHANICAL PARTS

PARTS ORDERING INFORMATION

Replacement parts are available from or through your local Tektronix, Inc. Field Office or representative.

Changes to Tektronix instruments are sometimes made to accommodate improved components as they become available, and to give you the benefit of the latest circuit improvements developed in our engineering department. It is therefore important, when ordering parts, to include the following information in your order: Part number, instrument type or number, serial number, and modification number if applicable.

If a part you have ordered has been replaced with a new or improved part, your local Tektronix, Inc. Field Office or representative will contact you concerning any change in part number.

Change information, if any, is located at the rear of this manual.

SPECIAL NOTES AND SYMBOLS

X000 Part first added at this serial number
00X Part removed after this serial number

FIGURE AND INDEX NUMBERS

Items in this section are referenced by figure and index numbers to the illustrations.

INDENTATION SYSTEM

This mechanical parts list is indented to indicate item relationships. Following is an example of the indentation system used in the description column.

```

1 2 3 4 5           Name & Description
Assembly and/or Component
Attaching parts for Assembly and/or Component
    --- * ---
Detail Part of Assembly and/or Component
Attaching parts for Detail Part
    --- * ---
Parts of Detail Part
Attaching parts for Parts of Detail Part
    --- * ---

```

Attaching Parts always appear in the same indentation as the item it mounts, while the detail parts are indented to the right. Indented items are part of, and included with, the next higher indentation. The separation symbol --- * --- indicates the end of attaching parts.

Attaching parts must be purchased separately, unless otherwise specified.

ITEM NAME

In the Parts List, an Item Name is separated from the description by a colon (:). Because of space limitations, an Item Name may sometimes appear as incomplete. For further Item Name identification, the U.S. Federal Cataloging Handbook H6-1 can be utilized where possible.

ABBREVIATIONS

"	INCH	ELCTRN	ELECTRON	IN	INCH	SE	SINGLE END
#	NUMBER SIZE	ELEC	ELECTRICAL	INCAND	INCANDESCENT	SECT	SECTION
ACTR	ACTUATOR	ELCTLT	ELECTROLYTIC	INSUL	INSULATOR	SEMICOND	SEMICONDUCTOR
ADPTR	ADAPTER	ELEM	ELEMENT	INTL	INTERNAL	SHLD	SHIELD
ALIGN	ALIGNMENT	EPL	ELECTRICAL PARTS LIST	LPHLDR	LAMPHOLDER	SHLDR	SHOULDERED
AL	ALUMINUM	EQPT	EQUIPMENT	MACH	MACHINE	SKT	SOCKET
ASSEM	ASSEMBLED	EXT	EXTERNAL	MECH	MECHANICAL	SL	SLIDE
ASSY	ASSEMBLY	FIL	FILLISTER HEAD	MTG	MOUNTING	SLFLKG	SELF-LOCKING
ATTEN	ATTENUATOR	FLEX	FLEXIBLE	NIP	NIPPLE	SLVG	SLEEVING
AWG	AMERICAN WIRE GAGE	FLH	FLAT HEAD	NON WIRE	NOT WIRE WOUND	SPR	SPRING
BD	BOARD	FLTR	FILTER	OBD	ORDER BY DESCRIPTION	SQ	SQUARE
BRKT	BRACKET	FR	FRAME or FRONT	OD	OUTSIDE DIAMETER	SST	STAINLESS STEEL
BRS	BRASS	FSTNR	FASTENER	OVH	OVAL HEAD	STL	STEEL
BRZ	BRONZE	FT	FOOT	PH BRZ	PHOSPHOR BRONZE	SW	SWITCH
BSHG	BUSHING	FXD	FIXED	PL	PLAIN or PLATE	T	TUBE
CAB	CABINET	GSKT	GASKET	PLSTC	PLASTIC	TERM	TERMINAL
CAP	CAPACITOR	HDL	HANDLE	PN	PART NUMBER	THD	THREAD
CER	CERAMIC	HEX	HEXAGON	PNH	PAN HEAD	THK	THICK
CHAS	CHASSIS	HEX HD	HEXAGONAL HEAD	PWR	POWER	TNSN	TENSION
CKT	CIRCUIT	HEX SOC	HEXAGONAL SOCKET	RCPT	RECEPTACLE	TPG	TAPPING
COMP	COMPOSITION	HLCPS	HELICAL COMPRESSION	RES	RESISTOR	TRH	TRUSS HEAD
CONN	CONNECTOR	HLEXT	HELICAL EXTENSION	RGD	RIGID	V	VOLTAGE
COV	COVER	HV	HIGH VOLTAGE	RLF	RELIEF	VAR	VARIABLE
CPLG	COUPLING	IC	INTEGRATED CIRCUIT	RTNR	RETAINER	W/	WITH
CRT	CATHODE RAY TUBE	ID	INSIDE DIAMETER	SCH	SOCKET HEAD	WSHR	WASHER
DEG	DEGREE	IDENT	IDENTIFICATION	SCOPE	OSCILLOSCOPE	XFMR	TRANSFORMER
DWR	DRAWER	IMPLR	IMPELLER	SCR	SCREW	XSTR	TRANSISTOR

CROSS INDEX - MFR. CODE NUMBER TO MANUFACTURER

Mfr. Code	Manufacturer	Address	City, State, Zip Code
00287	C E M CO INC	P O BOX 179	DANIELSON CT 06239
00779	AMP INC	P O BOX 3608	HARRISBURG PA 17105
12697	CLAROSTAT MFG CO INC	LOWER WASHINGTON ST	DOVER NH 03820
18203	ENGELMANN MICROWAVE CO	SKYLINE DRIVE	MONTVILLE NJ 07045
22526	DU PONT E I DE NEMOURS AND CO INC	515 FISHING CREEK RD	NEW CUMBERLAND PA 17070-3007
	DU PONT CONNECTOR SYSTEMS		
	DIV MILITARY PRODUCTS GROUP		
24931	SPECIALTY CONNECTOR CO INC	2620 ENDRESS PLACE P O BOX D	GREENWOOD IN 46142
73743	FISCHER SPECIAL MFG CO	446 MORGAN ST	CINCINNATI OH 45206
77900	SHAKEPROOF	SAINT CHARLES RD	ELGIN IL 60120
	DIV OF ILLINOIS TOOL WORKS		
79136	WALDES KOHINOOR INC	47-16 AUSTEL PLACE	LONG ISLAND CITY NY 11101
80009	TEKTRONIX INC	4900 S W GRIFFITH DR P O BOX 500	BEAVERTON OR 97077
83486	ELCO INDUSTRIES INC	1101 SAMUELSON RD	ROCKFORD IL 61101
93907	TEXTRON INC	600 18TH AVE	ROCKFORD IL 61101
	CAMCAR DIV		
98291	SEAELECTRO CORP	225 HOYT	MAMARONECK NY 10544
TK0392	NORTHWEST FASTENER SALES INC	7923 SW CIRRRUS DRIVE	BEAVERTON OR 97005
TK0435	LEWIS SCREW CO	4114 S PEORIA	CHICAGO IL 60609

Fig. & Index No.	Tektronix Part No.	Serial/Assembly No.		Qty	12345 Name & Description	Mfr.	
		Effective	Dscont			Code	Mfr. Part No.
1-1	386-1337-15	B010100	B051049	1	PANEL, REAR:	80009	386-1337-15
	386-1337-09	B051050		1	PANEL, REAR: (ATTACHING PARTS)	80009	386-1337-09
-2	211-0141-00			4	SCREW, MACHINE: 4-40 X 3.25, PNH, SST (END ATTACHING PARTS)	83486	ORDER BY DESCR
-3	380-0233-00			1	HSG, SAMPLING HD: ALUMINUM	80009	380-0233-00
-4	131-0555-00			4	.CONTACT, ELEC: GROUNDING, PH BRZ ALBALOY PL	80009	131-0555-00
-5	276-0174-00			1	FORM, DELAY LINE: EPOXY GLASS LAM, 2.092 X (ATTACHING PARTS)	80009	276-0174-00
-6	211-0008-00			1	SCREW, MACHINE: 4-40 X 0.25, PNH, STL (END ATTACHING PARTS)	93907	ORDER BY DESCR
-7	-----			1	CKT BOARD ASSY: TRIGGER (SEE A1 REPL)		
-8	351-0184-00			1	.POST, CKT BD MTG: 0.58 L X 0.219 OD BRS	80009	351-0184-00
-9	131-0582-00			1	.CONN, RCPT, ELEC: SNAP-ON, FEMALE, MODIFIED	98291	52-052-0049
-10	131-0591-00			2	.TERMINAL, PIN: 0.835 L X 0.025 SQ PH BRZ	22526	47332
-11	136-0252-07			9	.SOCKET, PIN CONN: W/O DIMPLE	22526	75060-012
-12	214-1081-00			2	.PIN, SPRING: 0.187 L X 0.034 OD, SST (ATTACHING PARTS)	00287	031X187MDP
-13	211-0162-00			2	SCREW, MACHINE: 2-56 X 0.188, SCH, SST (END ATTACHING PARTS)	TK0428	ORDER BY DESCR
-14	210-0707-00			2	EYELET, MTL: 0.089 OD X 0.093 L, BRS GOLD PL	12697	ORDER BY DESCR
-15	-----			1	CKT BOARD ASSY: TD DRIVER (SEE A1 REPL)		
-16	131-0391-00			1	.CONN, RCPT, ELEC: SNAP-ON, MALE	24931	32JR105-1
-17	136-0252-07			20	.SOCKET, PIN CONN: W/O DIMPLE	22526	75060-012
-18	175-1039-00			1	.CABLE ASSY, RF: 50 OHM COAX, 3.5 L	80009	175-1039-00
-19	131-0579-00			1	.CONN, RCPT, ELEC: MINTR BAYONET, MALE	24931	38JS106-1
-20	136-0263-03	B010100	B040319	2	SOCKET, PIN TERM: U/W 0.025 SQ PINS	00779	85864-2
	136-0263-04	B040320		2	SOCKET, PIN TERM: U/W 0.025 SQ PIN	22526	75377-001
-21	175-1264-00			1	.CABLE ASSY, RF: 50 OHM COAX, 1.5 L	80009	175-1264-00
-22	352-0133-00			1	.RTNR, ELEC CONN: BRASS ALBALOY	80009	352-0133-00
-23	131-0126-00			1	CONN, RCPT, ELEC: BNC, FEMALE (ATTACHING PARTS)	24931	28JR205-2
-24	220-0545-00			1	NUT, RTNG: 0.5-28 X 0.531 OD, BRS ALBALOY PL	80009	220-0545-00
-25	352-0178-01			1	HLDR, ELEC CONN: DBL D BNC, AL ALBALOY PL (END ATTACHING PARTS)	80009	352-0178-01
-26	384-0687-00	B010100	B029999	1	KNOB: 1.44 L X 0.125 OD, SST	80009	384-0687-00
-27	214-1226-01	B010100	B029999	1	SPRING, HLCP: 0.18 OD X 0.44 L, MUW CD PL	80009	214-1226-01
-28	105-0066-00	B010100	B029999	1	STRIKE, LATCH: SAMPLING HEAD	80009	105-0066-00
	105-0338-00	B030000		1	LATCH ASSEMBLY:	80009	105-0338-00
	354-0163-00			1	.RING, RETAINING: TYPE E EXT, U/O 0.125 ID SFT	79136	5133-12ZD
	384-0687-01			1	.KNOB: 1.44 L X 0.125 OD, SST	80009	384-0687-01
	105-0336-00			1	.STRIKE, CATCH:	80009	105-0336-00
-29	366-1023-00	B010100	B019999	2	KNOB: GY, 0.127 ID X 0.392 OD X 0.531 H	80009	366-1023-00
	366-1023-01	B020000		1	KNOB: GY, 0.127 ID X 0.392 OD X 0.531 H	80009	366-1023-01
	213-0153-00			1	.SETScrew: 5-40 X 0.125, STL	TK0392	ORDER BY DESCR
-30	366-1023-00	B010100	B019999	1	KNOB: GY, 0.127 ID X 0.392 OD X 0.531 H	80009	366-1023-00
	366-1023-01	B020000		1	KNOB: GY, 0.127 ID X 0.392 OD X 0.531 H	80009	366-1023-01
	213-0153-00			1	.SETScrew: 5-40 X 0.125, STL	TK0392	ORDER BY DESCR
-31	333-1424-00			1	PANEL, FRONT: (ATTACHING PARTS)	80009	333-1424-00
-32	211-0022-00			1	SCREW, MACHINE: 2-56 X 0.188, PNH, STL (END ATTACHING PARTS)	TK0435	ORDER BY DESCR
-33	-----			1	SWITCH, TOGGLE: (SEE S10 REPL) (ATTACHING PARTS)		
-34	210-0562-00			2	NUT, PLAIN, HEX: 0.25-40 X 0.312 BRS CD PL	73743	20224-402
-35	210-0046-00			1	WASHER, LOCK: 0.261 ID, INTL, 0.018 THK, STL (END ATTACHING PARTS)	77900	1214-05-00-0541C
-36	-----			1	RESISTOR, VARIABLE: (ATTACHING PARTS)		
-37	210-0583-00			2	NUT, PLAIN, HEX: 0.25-32 X 0.312, BRS CD PL	73743	2X-20319-402
-38	210-0046-00			1	WASHER, LOCK: 0.261 ID, INTL, 0.018 THK, STL (END ATTACHING PARTS)	77900	1214-05-00-0541C
-39	-----			1	RESISTOR, VARIABLE: (ATTACHING PARTS)		
-40	210-0583-00			2	NUT, PLAIN, HEX: 0.25-32 X 0.312, BRS CD PL (END ATTACHING PARTS)	73743	2X-20319-402
-41	386-1338-17			1	SUBPANEL, FRONT:	80009	386-1338-17

Replaceable Mechanical Parts - S-53

Fig. & Index No.	Tektronix Part No.	Serial/Assembly No. Effective	Discnt	Qty.	12345 Name & Description	Mfr. Code	Mfr. Part No.
1-					STANDARD ACCESSORIES		
	011-0059-01	B010100	B040199	1	ATTENUATOR, FXD:10X ATTN, 50 OHM, BNC	80009	011-0059-01
	011-0059-02	B040200		1	ATTENUATOR, FXD:10:1 ATTN, 50 OHM, BNC	18203	A314-ES
	012-0057-01			1	CABLE ASSY, RF:50 OHM COAX, 43.0 L	80009	012-0057-01
	070-1147-00			1	MANUAL, TECH: INSTRUCTION	80009	070-1147-00

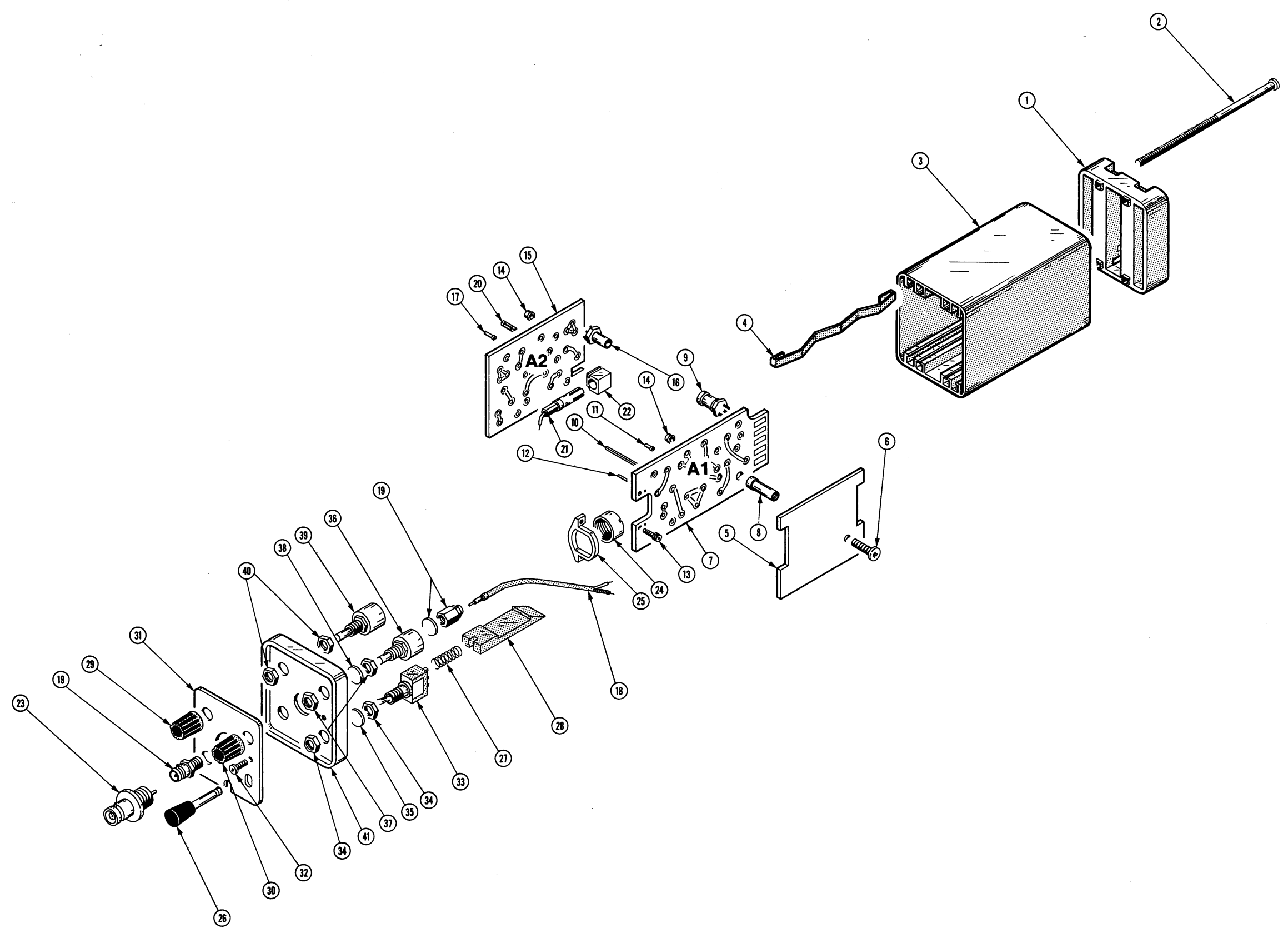

MANUAL CHANGE INFORMATION

At Tektronix, we continually strive to keep up with latest electronic developments by adding circuit and component improvements to our instruments as soon as they are developed and tested.

Sometimes, due to printing and shipping requirements, we can't get these changes immediately into printed manuals. Hence, your manual may contain new change information on following pages.

A single change may affect several sections. Since the change information sheets are carried in the manual until all changes are permanently entered, some duplication may occur. If no such change pages appear following this page, your manual is correct as printed.