

# Bimetal Thermometer

## Model TI.52, Stainless Steel Case & Wetted Parts

Datasheet TI.52

### Applications

- Suitable for fluid medium which does not corrode 304 stainless steel

### Special features

- Industrial design
- Adjustable angle connection with external reset
- Stainless steel case and wetted parts

### Standard version

#### Size

5" (127mm) Type TI.52

#### Accuracy

+ 1.0% full scale value (ASME B40.3)

#### Ranges

-100 °F to 1000 °F (and equivalent Celsius)

#### Working Range

Steady: full scale value

Short time: 110% of full scale value

#### Over Range

Temporary over or under range tolerance of 50% of scale up to 500 °F. (260°C). For ranges above 500°F, maximum over range is 800°F; continuous. 1000°F intermittent.

#### Connection

Material: 304 stainless steel

Adjustable angle, 1/2" NPT

#### Stem

Material: 304 stainless steel

Diameter: 1/4" (6.35 mm)

Length: 2½" to 72" (63.5 mm to 1,828.8 mm)

#### Measuring Element

Bi-metal helix

#### Dial

White aluminum, dished, with black markings



#### Thermometer TI.52

##### Case

Material: 304 stainless steel

Hermetically sealed per ASME B40.3 standard

Ingress protection IP 65

External reset slotted hex head on back of case

##### Pointer

Black aluminum

##### Standard Scales

Single: Fahrenheit or Celsius

Dual: Fahrenheit (outer) and Celsius (inner)

##### Window Gasket

Neoprene

Silicone (-100 °F and over 550 °F)

##### Window

Flat instrument glass

##### Weight

26 oz. (5" dial)

Add 1 oz for every 2" of stem length

##### Dampening

Inert gel to minimize pointer oscillation

##### Movement

Viscous inert gel to enhance pointer operation

##### Warranty

7- Year Warranty

## Optional Extras

- Thermowells
- Silicone fill
- Dampened Movement
- Special scales and dial markings
- Acrylic and safety glass windows
- Calibration certification traceable to NIST
- Min/max pointer
- DIN standards

### STANDARD RANGES

Fahrenheit	Dual Scale F & C	Celsius
Single Scale	F Outer, C Inner	Single Scale
-100/150 F	-100/150 F & -70/70 C	-50/50 C
-40/120 F	40/120 F & -40/50 C	-20/120 C
0/140 F	0/140 F & -20/60 C	0/50 C <sup>1</sup>
0/200 F	0/200 F & -15/90 C	0/100 C
0/250 F	0/250 F & -20/120 C	0/150 C
20/240 F	20/240 F & -5/115 C	0/200 C
25/125 F <sup>1</sup>	25/125 F & -5/50 C <sup>1</sup>	0/250 C
50/300 F	50/300 F & 10/150 C	0/300 C
50/400 F	50/400 F & 10/200 C	0/450 C <sup>2</sup>
50/550 F	50/500 F & 10/260 C	100/550 C <sup>2</sup>
150/750 F	150/750 F & 65/400 C	
200/1000 F <sup>2</sup>	200/1000 F & 100/540 C <sup>2</sup>	

<sup>1</sup>Minimum stem length 4" for Type 52

<sup>2</sup>Not recommended for continuous service over 800°F (425°C)

## Dimensions

### Standard versions

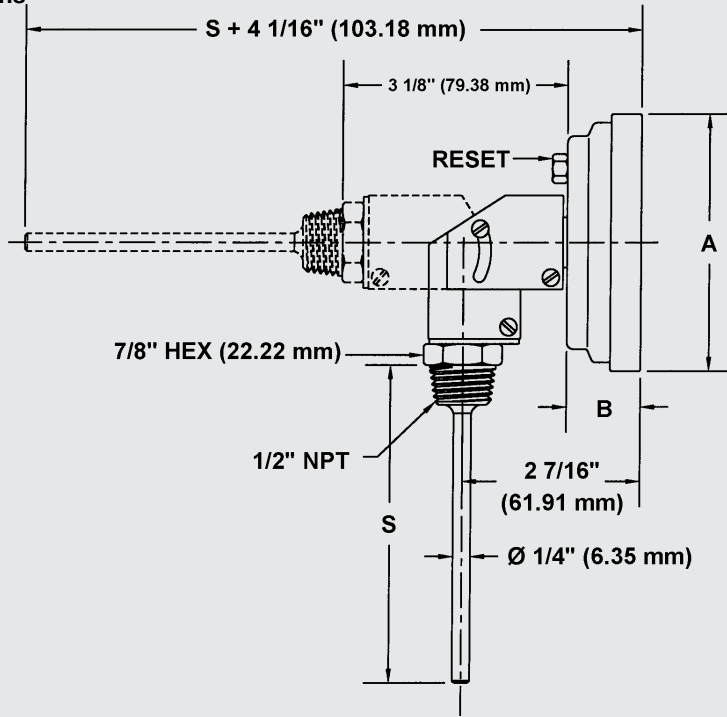

Stem Length
2½" (63.5 mm)
4" (101.6 mm)
6" (152.4 mm)
9" (228.6 mm)
12" (304.8 mm)
15" (381.0 mm)
18" (457.2 mm)
24" (609.6 mm)

WIKA Type	DIAL SIZE	A	B	S (Stem Length)
52	5" (127 mm)	5-1/4" (133.35 mm)	15/16" (23.8 mm)	As Specified

Note: Thermowells for temperature instruments are recommended for all process systems where pressure, velocity, or viscous, abrasive and corrosive materials are present individually or in combination. A properly selected thermowell protects the temperature instrument from possible damage resulting from these process variables. Furthermore, a thermowell permits removal of the temperature instrument for replacement, repair or testing without effecting the process media or the system.

#### Ordering information

State computer part number (if available) /type number/size/range/connection size and locations/options required. WIKA reserves the right to make changes without prior notice.