

PXI

NI PXI-1042 Series User Manual

Worldwide Technical Support and Product Information

ni.com

National Instruments Corporate Headquarters

11500 North Mopac Expressway Austin, Texas 78759-3504 USA Tel: 512 683 0100

Worldwide Offices

Australia 1800 300 800, Austria 43 0 662 45 79 90 0, Belgium 32 0 2 757 00 20, Brazil 55 11 3262 3599,
Canada (Calgary) 403 274 9391, Canada (Ottawa) 613 233 5949, Canada (Québec) 450 510 3055,
Canada (Toronto) 905 785 0085, Canada (Vancouver) 514 685 7530, China 86 21 6555 7838,
Czech Republic 420 224 235 774, Denmark 45 45 76 26 00, Finland 385 0 9 725 725 11,
France 33 0 1 48 14 24 24, Germany 49 0 89 741 31 30, Greece 30 2 10 42 96 427, India 91 80 51190000,
Israel 972 0 3 6393737, Italy 39 02 413091, Japan 81 3 5472 2970, Korea 82 02 3451 3400,
Malaysia 603 9131 0918, Mexico 001 800 010 0793, Netherlands 31 0 348 433 466,
New Zealand 0800 553 322, Norway 47 0 66 90 76 60, Poland 48 22 3390150, Portugal 351 210 311 210,
Russia 7 095 783 68 51, Singapore 65 6226 5886, Slovenia 386 3 425 4200, South Africa 27 0 11 805 8197,
Spain 34 91 640 0085, Sweden 46 0 8 587 895 00, Switzerland 41 56 200 51 51, Taiwan 886 2 2528 7227,
Thailand 662 992 7519, United Kingdom 44 0 1635 523545

For further support information, refer to the *Technical Support and Professional Services* appendix. To comment on the documentation, send email to techpubs@ni.com.

Important Information

Warranty

The NI PXI-1042 Series chassis are warranted against defects in materials and workmanship for a period of one year from the date of shipment, as evidenced by receipts or other documentation. National Instruments will, at its option, repair or replace equipment that proves to be defective during the warranty period. This warranty includes parts and labor.

The media on which you receive National Instruments software are warranted not to fail to execute programming instructions, due to defects in materials and workmanship, for a period of 90 days from date of shipment, as evidenced by receipts or other documentation. National Instruments will, at its option, repair or replace software media that do not execute programming instructions if National Instruments receives notice of such defects during the warranty period. National Instruments does not warrant that the operation of the software shall be uninterrupted or error free.

A Return Material Authorization (RMA) number must be obtained from the factory and clearly marked on the outside of the package before any equipment will be accepted for warranty work. National Instruments will pay the shipping costs of returning to the owner parts which are covered by warranty.

National Instruments believes that the information in this document is accurate. The document has been carefully reviewed for technical accuracy. In the event that technical or typographical errors exist, National Instruments reserves the right to make changes to subsequent editions of this document without prior notice to holders of this edition. The reader should consult National Instruments if errors are suspected. In no event shall National Instruments be liable for any damages arising out of or related to this document or the information contained in it.

EXCEPT AS SPECIFIED HEREIN, NATIONAL INSTRUMENTS MAKES NO WARRANTIES, EXPRESS OR IMPLIED, AND SPECIFICALLY DISCLAIMS ANY WARRANTY OF MERCHANTABILITY OR FITNESS FOR A PARTICULAR PURPOSE. CUSTOMER'S RIGHT TO RECOVER DAMAGES CAUSED BY FAULT OR NEGLIGENCE ON THE PART OF NATIONAL INSTRUMENTS SHALL BE LIMITED TO THE AMOUNT THEREOF PAID BY THE CUSTOMER. NATIONAL INSTRUMENTS WILL NOT BE LIABLE FOR DAMAGES RESULTING FROM LOSS OF DATA, PROFITS, USE OF PRODUCTS, OR INCIDENTAL OR CONSEQUENTIAL DAMAGES, EVEN IF ADVISED OF THE POSSIBILITY THEREOF. This limitation of the liability of National Instruments will apply regardless of the form of action, whether in contract or tort, including negligence. Any action against National Instruments must be brought within one year after the cause of action accrues. National Instruments shall not be liable for any delay in performance due to causes beyond its reasonable control. The warranty provided herein does not cover damages, defects, malfunctions, or service failures caused by owner's failure to follow the National Instruments installation, operation, or maintenance instructions; owner's modification of the product; owner's abuse, misuse, or negligent acts; and power failure or surges, fire, flood, accident, actions of third parties, or other events outside reasonable control.

Copyright

Under the copyright laws, this publication may not be reproduced or transmitted in any form, electronic or mechanical, including photocopying, recording, storing in an information retrieval system, or translating, in whole or in part, without the prior written consent of National Instruments Corporation.

Trademarks

National Instruments™, NI™, and ni.com™ are trademarks of National Instruments Corporation.

Product and company names mentioned herein are trademarks or trade names of their respective companies.

Patents

For patents covering National Instruments products, refer to the appropriate location: **Help»Patents** in your software, the `patents.txt` file on your CD, or `ni.com/patents`.

WARNING REGARDING USE OF NATIONAL INSTRUMENTS PRODUCTS

(1) NATIONAL INSTRUMENTS PRODUCTS ARE NOT DESIGNED WITH COMPONENTS AND TESTING FOR A LEVEL OF RELIABILITY SUITABLE FOR USE IN OR IN CONNECTION WITH SURGICAL IMPLANTS OR AS CRITICAL COMPONENTS IN ANY LIFE SUPPORT SYSTEMS WHOSE FAILURE TO PERFORM CAN REASONABLY BE EXPECTED TO CAUSE SIGNIFICANT INJURY TO A HUMAN.

(2) IN ANY APPLICATION, INCLUDING THE ABOVE, RELIABILITY OF OPERATION OF THE SOFTWARE PRODUCTS CAN BE IMPAIRED BY ADVERSE FACTORS, INCLUDING BUT NOT LIMITED TO FLUCTUATIONS IN ELECTRICAL POWER SUPPLY, COMPUTER HARDWARE MALFUNCTIONS, COMPUTER OPERATING SYSTEM SOFTWARE FITNESS, FITNESS OF COMPILERS AND DEVELOPMENT SOFTWARE USED TO DEVELOP AN APPLICATION, INSTALLATION ERRORS, SOFTWARE AND HARDWARE COMPATIBILITY PROBLEMS, MALFUNCTIONS OR FAILURES OF ELECTRONIC MONITORING OR CONTROL DEVICES, TRANSIENT FAILURES OF ELECTRONIC SYSTEMS (HARDWARE AND/OR SOFTWARE), UNANTICIPATED USES OR MISUSES, OR ERRORS ON THE PART OF THE USER OR APPLICATIONS DESIGNER (ADVERSE FACTORS SUCH AS THESE ARE HEREAFTER COLLECTIVELY TERMED "SYSTEM FAILURES"). ANY APPLICATION WHERE A SYSTEM FAILURE WOULD CREATE A RISK OF HARM TO PROPERTY OR PERSONS (INCLUDING THE RISK OF BODILY INJURY AND DEATH) SHOULD NOT BE RELIANT SOLELY UPON ONE FORM OF ELECTRONIC SYSTEM DUE TO THE RISK OF SYSTEM FAILURE. TO AVOID DAMAGE, INJURY, OR DEATH, THE USER OR APPLICATION DESIGNER MUST TAKE REASONABLY PRUDENT STEPS TO PROTECT AGAINST SYSTEM FAILURES, INCLUDING BUT NOT LIMITED TO BACK-UP OR SHUT DOWN MECHANISMS. BECAUSE EACH END-USER SYSTEM IS CUSTOMIZED AND DIFFERS FROM NATIONAL INSTRUMENTS' TESTING PLATFORMS AND BECAUSE A USER OR APPLICATION DESIGNER MAY USE NATIONAL INSTRUMENTS PRODUCTS IN COMBINATION WITH OTHER PRODUCTS IN A MANNER NOT EVALUATED OR CONTEMPLATED BY NATIONAL INSTRUMENTS, THE USER OR APPLICATION DESIGNER IS ULTIMATELY RESPONSIBLE FOR VERIFYING AND VALIDATING THE SUITABILITY OF NATIONAL INSTRUMENTS PRODUCTS WHENEVER NATIONAL INSTRUMENTS PRODUCTS ARE INCORPORATED IN A SYSTEM OR APPLICATION, INCLUDING, WITHOUT LIMITATION, THE APPROPRIATE DESIGN, PROCESS AND SAFETY LEVEL OF SUCH SYSTEM OR APPLICATION.

Contents

About This Manual

Conventions	vii
Related Documentation.....	viii

Chapter 1

Getting Started

Unpacking	1-1
What You Need to Get Started	1-1
Key Features	1-2
Chassis Description.....	1-3
Optional Equipment	1-5
EMC Filler Panels	1-5
Rack Mount Kits.....	1-5
Slot Blockers	1-6
PXI-1042 Series Backplane Overview	1-6
Interoperability with CompactPCI	1-6
System Controller Slot	1-6
Star Trigger Slot	1-7
Peripheral Slots.....	1-7
Local Bus	1-7
Trigger Bus	1-8
System Reference Clock.....	1-8

Chapter 2

Installation and Configuration

Chassis Cooling Considerations	2-1
Providing Adequate Clearance	2-1
Setting Fan Speed	2-2
Installing Filler Panels	2-2
Installing Slot Blockers	2-3
Rack Mounting	2-3
Connecting Safety Ground.....	2-3
Connecting to Power Source.....	2-4
Installing a PXI Controller.....	2-4
Installing PXI Modules	2-6
Power Switch LED Indicator	2-8
Remote Voltage Monitoring and Control	2-8

PXI_CLK10 Rear Connectors	2-10
10 MHz REF IN	2-10
10 MHz REF OUT	2-10
Using System Configuration and Initialization Files	2-11

Chapter 3

Maintenance

Service Interval	3-1
Preparation	3-1
Cleaning	3-2
Interior Cleaning	3-2
Exterior Cleaning	3-2
Cleaning and Replacing the Fan Filters	3-2
Resetting the AC Mains Circuit Breaker	3-3
Replacing the Modular Power Supply	3-4
Removal	3-4
Installation	3-4
Configuration	3-5
Connecting Safety Ground	3-5
Connecting to Power Source	3-5

Appendix A

Specifications

Appendix B

Pinouts

Appendix C

Technical Support and Professional Services

Glossary



Index

About This Manual

The *NI PXI-1042 Series User Manual* describes the features of the PXI-1042 Series chassis and contains information about configuring the chassis, installing the modules, and operating and using the PXI-1042 Series chassis.

Conventions

The following conventions are used in this manual:

- » The » symbol leads you through nested menu items and dialog box options to a final action. The sequence **File»Page Setup»Options** directs you to pull down the **File** menu, select the **Page Setup** item, and select **Options** from the last dialog box.
-  This icon denotes a note, which alerts you to important information.
-  This icon denotes a caution, which advises you of precautions to take to avoid injury, data loss, or a system crash. When this symbol is marked on the product, refer to the *Read Me First: Safety and Radio-Frequency Interference* document, shipped with the product, for precautions to take.
- bold** Bold text denotes items that you must select or click in the software, such as menu items and dialog box options. Bold text also denotes parameter names.
- italic* Italic text denotes variables, emphasis, a cross reference, or an introduction to a key concept. This font also denotes text that is a placeholder for a word or value that you must supply.
- monospace Text in this font denotes text or characters that you should enter from the keyboard, sections of code, programming examples, and syntax examples. This font is also used for the proper names of disk drives, paths, directories, programs, subprograms, subroutines, device names, functions, operations, variables, filenames, and extensions.
- PXI-1042/PXI-1042Q The PXI-1042 chassis appears in the views throughout the manual. The mechanical features are identical between the PXI-1042 and the PXI-1042Q chassis unless otherwise noted.

Related Documentation

The following documents contain information that you might find helpful as you read this manual:

- *Compact PCI Specification PICMG 2.0 R 3.0*
- *PXI Specification, Revision 2.0*
- *IEEE 1101.1-1991, IEEE Standard for Mechanical Core Specifications for Microcomputers Using IEC 603-2 Connectors*
- *IEEE 1101.10, IEEE Standard for Additional Mechanical Specifications for Microcomputers Using IEEE 1101.1 Equipment Practice*

Getting Started

This chapter describes the key features of the PXI-1042 Series chassis and lists the kit contents and optional equipment you can order from National Instruments.

Unpacking

Carefully inspect the shipping container and the chassis for damage. Check for visible damage to the metal work. Check to make sure all handles, hardware, and switches are undamaged. Inspect the inner chassis for any possible damage, debris, or detached components. If damage appears to have been caused during shipment, file a claim with the carrier. Retain the packing material for possible inspection and/or reshipment.

What You Need to Get Started

The PXI-1042 Series kit contains the following items:

- PXI-1042 or PXI-1042Q chassis
- Filler panels
- AC power cable (refer to Table 1-1 for AC power cables)
- NI PXI-1042 Series User Manual*
- Software media with Chassis Initialization file, `chassis.ini`
- Read Me First: Safety and Radio-Frequency Interference*

Table 1-1. AC Power Cables

Power Cable	Reference Standards
Standard 120 V (USA)	ANSI C73.11/NEMA 5-15-P/IEC83
Switzerland 220 V	SEV
Australia 240 V	AS C112
Universal Euro 230 V	CEE (7), II, IV, VII IEC83
North America 120 V	ANSI C73.20/NEMA 5-15-P/IEC83
United Kingdom 230 V	BS 1363/IEC83

If you are missing any of the items listed in Table 1-1, or if you have the incorrect AC power cable, contact National Instruments.

Key Features

The PXI-1042 Series combines a high-performance 8-slot PXI backplane with a high-output power supply and a structural design that has been optimized for maximum usability in a wide range of applications. The chassis' modular design ensures a high level of maintainability, resulting in a very low mean time to repair (MTTR). The PXI-1042 Series fully comply with the *PXI Specification, Revision 2.0*, offering advanced timing and synchronization features.

The key features of the PXI-1042 Series include the following:

- PXI and CompactPCI (PICMG 2.0 R 3.0) module compatibility
- Compact 3U-sized, 8-slot chassis
- Universal AC input: automatic voltage and frequency ranging
- Over-current protection through push-reset circuit breaker (no AC-input fuses to replace)
- Removable modular power-supply shuttle
- Remote voltage monitoring and inhibit through a rear-panel connector
- On/Off (Standby) power switch on the front panel for easy access
- Temperature-sensing module that can adjust fan speed based on air-intake temperature to minimize audible noise

- Front-panel LED that can indicate power supply failure
- Carrying handle for portability
- Tilt feet for bench-top applications

Chassis Description

Figures 1-1 and 1-2 show the key features of the PXI-1042 chassis front and back panels. Figure 1-1 shows the front view of the PXI-1042. Figure 1-2 shows the rear view of the PXI-1042. Figure 1-3 shows the rear view of the PXI-1042Q.

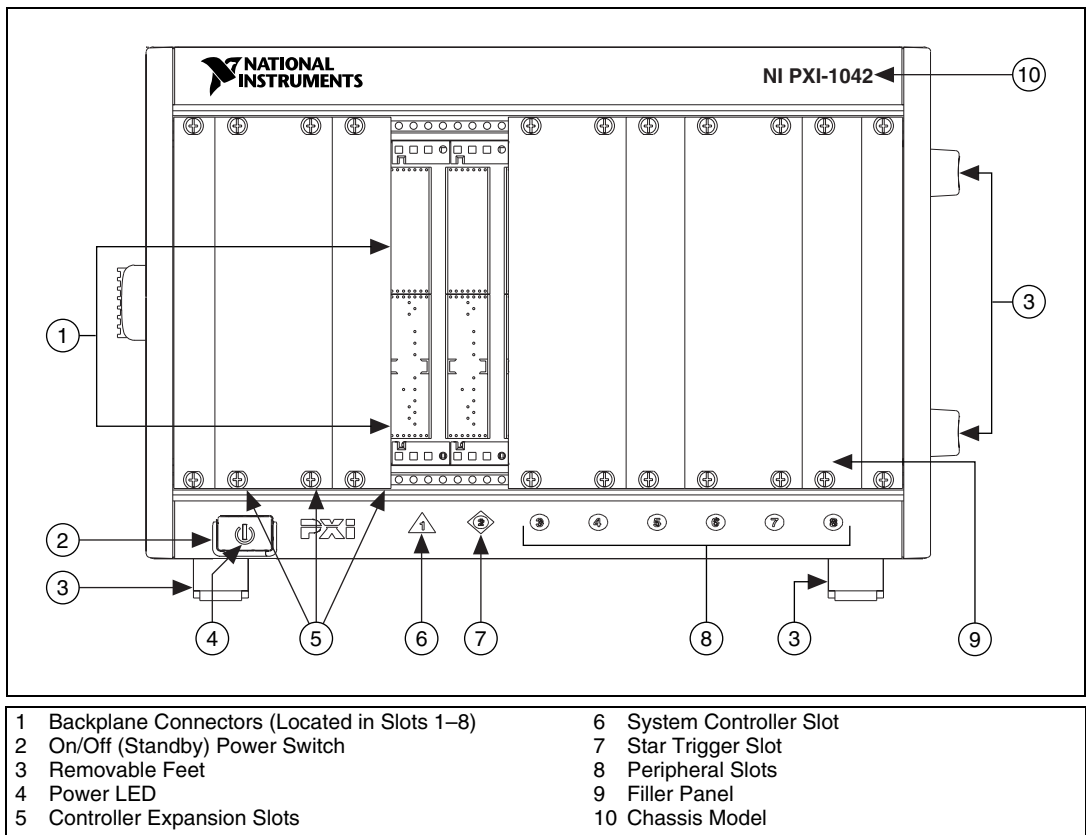

Figure 1-1. Front View of the PXI-1042 Chassis

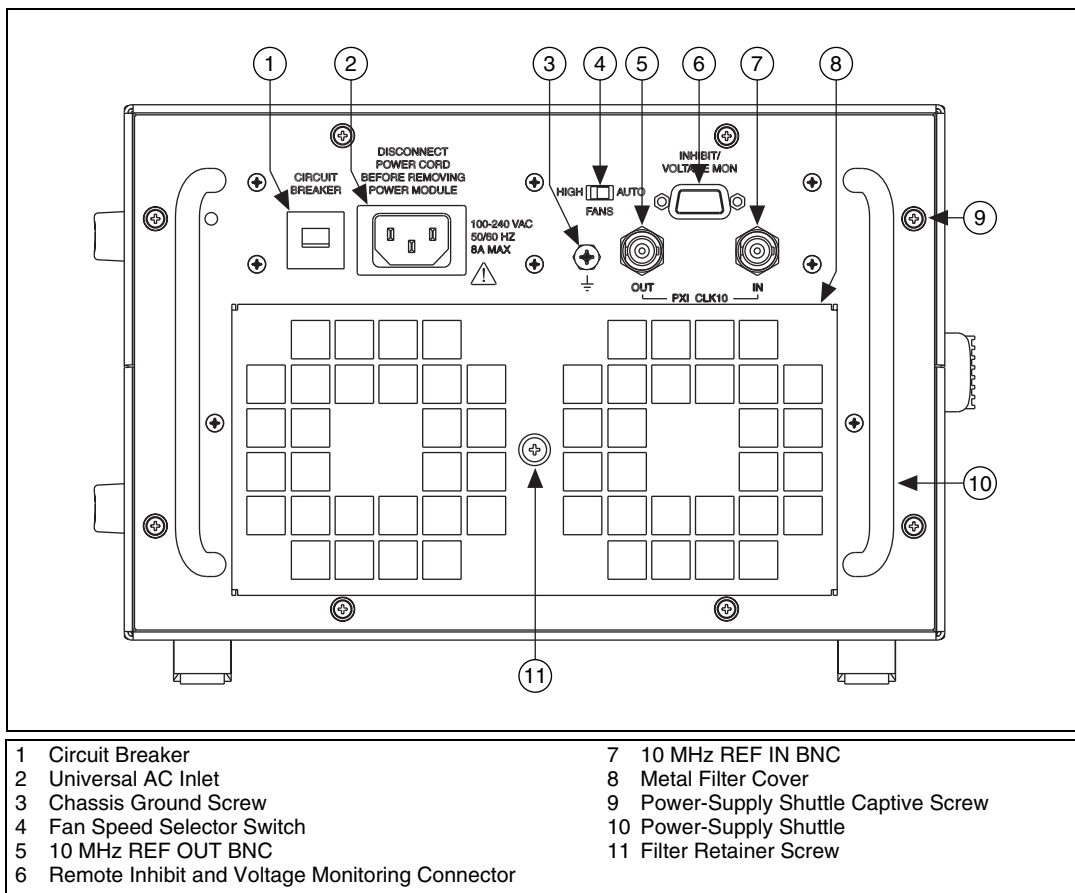

Figure 1-2. Rear View of the PXI-1042 Chassis

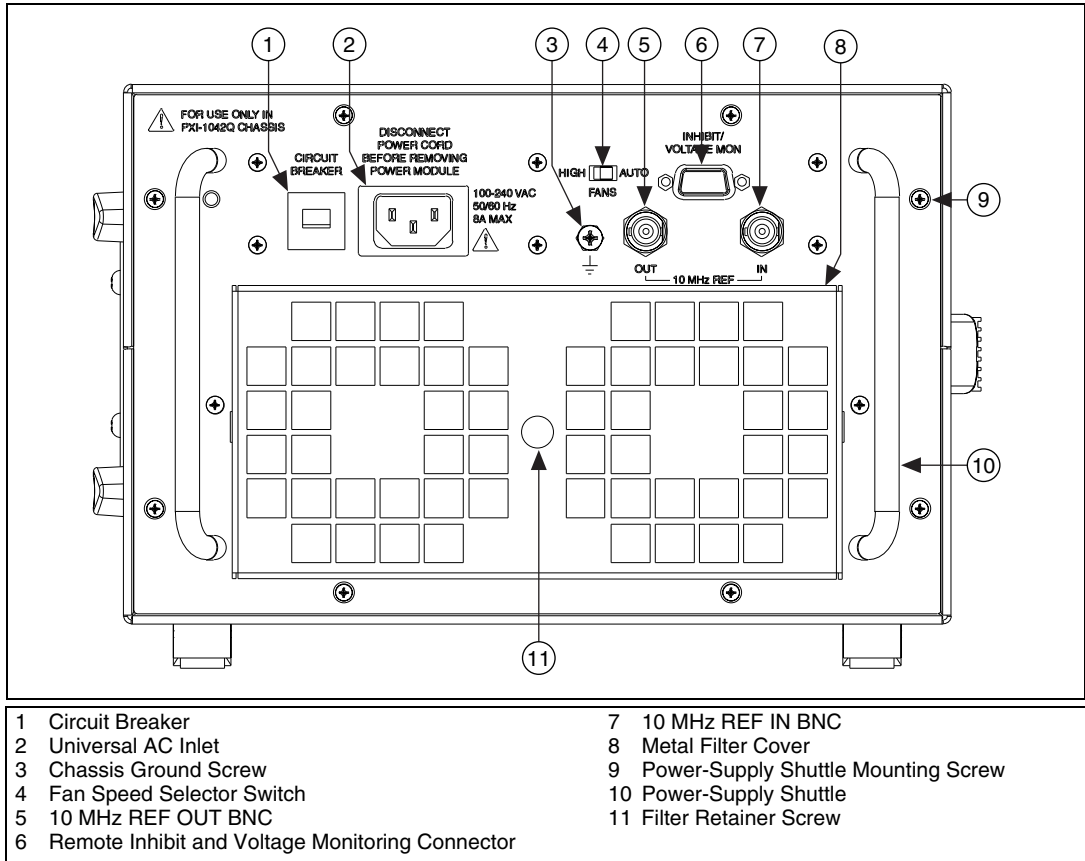

Figure 1-3. Rear View of the PXI-1042Q Chassis

Optional Equipment

Contact National Instruments to order the following options for the PXI-1042 Series chassis.

EMC Filler Panels

Optional EMC filler panel kits are available from National Instruments.

Rack Mount Kits

Two rack mount kit options are available for mounting the PXI-1042 Series chassis into a 19 in. instrument cabinet.

The first option is a pair of mounting brackets for use on the front of the chassis. The second option is a rear rack mount kit. The rear rack mount kit differs from the front kit to allow for easier installation into the rack. For more information, refer to Figure A-3, *PXI-1042 Series Chassis Rack Mount Kit Components*.

Slot Blockers

Optional slot blocker kits are available from National Instruments for improved thermal performance when all slots are not used.

PXI-1042 Series Backplane Overview

Interoperability with CompactPCI

The PXI-1042 Series backplane is interoperable with PXI-compatible products and standard CompactPCI products. This is an important feature, because some PXI systems may require components that do not implement PXI-specific features. For example, you may want to use a standard CompactPCI network interface card in a PXI chassis.

The signals on the backplane P1 connector meet the requirements of the CompactPCI specification for both the peripheral and system modules.

The PXI-specific signals are on the P2 connector and are found only on the signal lines reserved or not used in the CompactPCI 64-bit specification. Therefore, all modules that meet the requirements of the CompactPCI 64-bit specification will function in the PXI-1042 Series.

System Controller Slot

The system controller slot is Slot 1 of the chassis as defined by the PXI specification. It has three controller expansion slots for system controller modules that are wider than one slot. As defined in the PXI specification, these slots allow the controller to expand to the left to prevent the controller from using peripheral slots.

Star Trigger Slot

The Star Trigger (ST) slot is Slot 2. This slot has dedicated equal-length trigger lines between Slot 2 and each remaining peripheral slot (refer to Figure 1-4). This slot is intended for modules with ST functionality that can provide individual triggers to all other peripheral modules. However, if you do not require advanced trigger functionality, you can install any standard peripheral module in this slot.

Peripheral Slots

There are seven peripheral slots including the Star Trigger slot.

Local Bus

The PXI backplane local bus is a daisy-chained bus that connects each peripheral slot with adjacent peripheral slots to the left and right, as shown in Figure 1-4.

The left local bus signals on Slot 2 are used for Star Trigger and do not connect to Slot 1. The right local bus signals on Slot 8 are not routed anywhere.

For example, a given peripheral slot's right local bus connects to the adjacent slot's left local bus, and so on. Each local bus is 13 lines wide and can pass analog signals between cards or provide a high-speed side-band digital communication path that does not reduce the PXI bus bandwidth.

Local bus signals may range from high-speed TTL signals to analog signals as high as 42 V.

Initialization software uses the configuration information specific to each adjacent peripheral module to evaluate local bus compatibility.

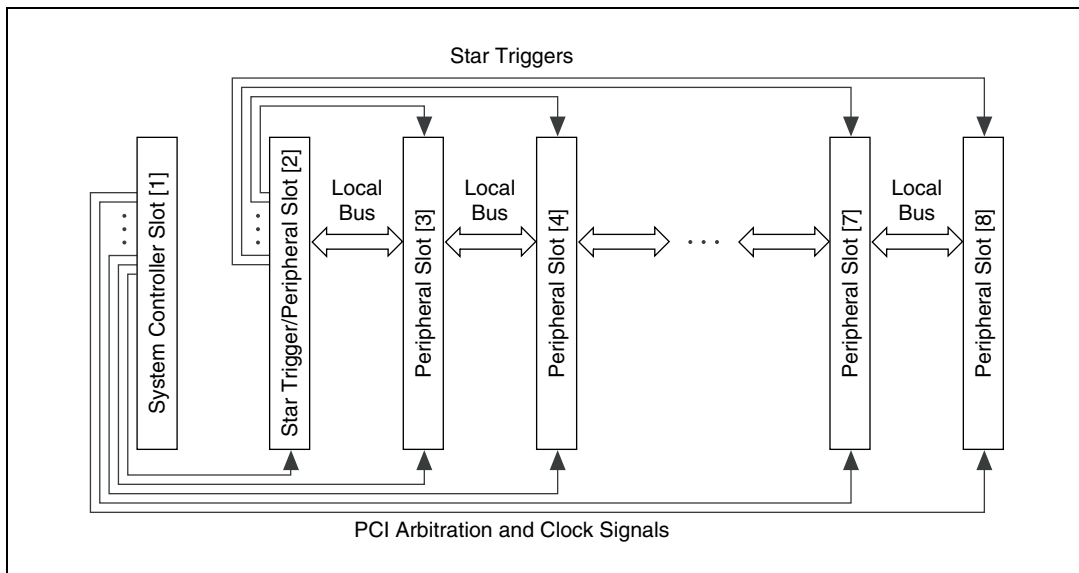

Figure 1-4. PXI Local Bus and Star Trigger Routing

Trigger Bus

All slots share eight trigger lines. You can use these trigger lines in a variety of ways. For example, you can use triggers to synchronize the operation of several different PXI peripheral modules. In other applications, one module can control carefully timed sequences of operations performed on other modules in the system. Modules can pass triggers to one another, allowing precisely timed responses to asynchronous external events the system is monitoring or controlling.

System Reference Clock

The PXI-1042 Series chassis supply the PXI 10 MHz system clock signal (PXI_CLK10) independently to each peripheral slot. An independent buffer (having a source impedance matched to the backplane and a skew of less than 250 ps between slots) drives the clock signal to each peripheral slot. You can use this common reference clock signal to synchronize multiple modules in a measurement or control system. You can drive PXI_CLK10 from an external source through the PXI_CLK10_IN pin on the P2 connector of the Star Trigger Slot. Refer to Table B-4, [P2 \(J2\) Connector Pinout for the Star Trigger Slot](#). Sourcing an external clock on this pin automatically replaces the backplane's 10 MHz source. You also can drive PXI_CLK10 from the 10 MHz REF IN connector on the rear of the chassis. Sourcing an external clock on this connector automatically

overrides the backplane's 10 MHz clock. If the clock signal is present on both the PXI_CLK10_IN pin of the Star Trigger Slot and the 10 MHz REF IN connector on the rear of the chassis, the signal on the Star Trigger Slot is selected and provided to all peripheral slots and the external 10 MHz REF OUT connector on the rear of the chassis.

Installation and Configuration

This chapter describes how to prepare and operate the PXI-1042 Series chassis.

Before connecting the chassis to a power source, read this chapter and the *Read Me First: Safety and Radio-Frequency Interference* document included with your kit.

Chassis Cooling Considerations

The PXI-1042 Series chassis are designed to operate on a bench or in an instrument rack. Determine how you want to use the chassis and follow the appropriate installation instructions.

Providing Adequate Clearance

Apertures in the top and along both sides of the chassis facilitate power supply and module cooling. Air enters through filters and fan inlets in the lower rear of the chassis and exits through the upper sections on both sides and through the top, as shown in Figure 2-1. Place the chassis on a bench top or in an instrument rack so that the fans (air inlets) and the air outlet apertures along both sides and the top of the chassis have adequate ventilation. Keep other equipment a minimum of 3 in. away from the air inlets on the rear of the chassis.

When rack mounting a PXI-1042 Series chassis, provide 1.75 in. (44.5 mm) clearance above and on the sides of the unit for adequate venting. High-power applications may require additional clearance.

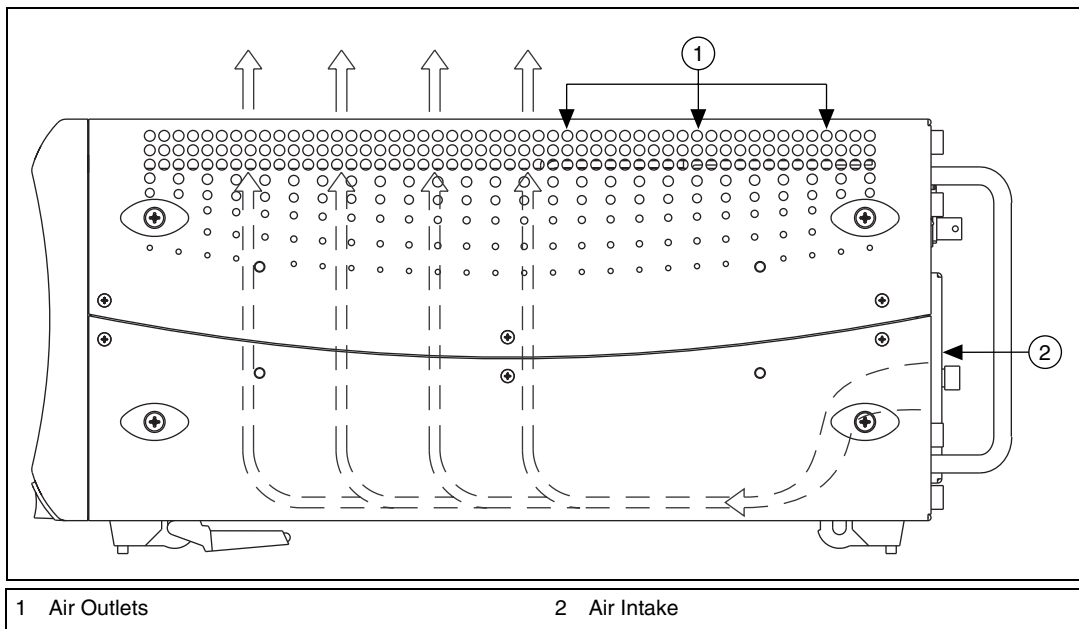

Figure 2-1. PXI-1042 Series Chassis Airflow Side View

Install the chassis so that you can easily access the rear panel. This simplifies replacing the air filters or power supply shuttle assembly, if necessary.

Setting Fan Speed

The fan-speed selector switch is on the rear panel of the PXI-1042 Series chassis. Refer to Figure 1-2, *Rear View of the PXI-1042 Chassis*, and Figure 1-3, *Rear View of the PXI-1042Q Chassis*, to locate the fan-speed selector switch. Select HIGH for maximum cooling performance (recommended) or AUTO for quieter operation. When set to AUTO, the fan speed is determined by chassis intake air temperature.

Installing Filler Panels

To improve module cooling performance, install filler panels (provided with the chassis) in unused or empty slots. Secure with the captive mounting screws provided.

Installing Slot Blockers

The cooling performance of the chassis can be improved by installing optional slot blockers. Refer to ni.com for more details.

Rack Mounting

Rack mount applications require the optional rack mount kits available from National Instruments. Refer to the instructions supplied with the rack mount kits to install your PXI-1042 Series in an instrument rack. Refer to Figure A-3, *PXI-1042 Series Chassis Rack Mount Kit Components*.



Note You may want to remove the feet from the PXI-1042 Series when rack mounting. To do so, remove the screws holding the feet in place.

Connecting Safety Ground



Caution The PXI-1042 Series chassis are designed with a three-position NEMA 5-15 style plug for the U.S. that connects the ground line to the chassis ground. To minimize shock hazard, make sure the electrical power outlet you use to power the chassis has an appropriate earth safety ground.

If your power outlet does not have an appropriate ground connection, you must connect the premise safety ground to the chassis grounding screw located on the rear panel. Refer to Figure 1-2, *Rear View of the PXI-1042 Chassis*, and Figure 1-3, *Rear View of the PXI-1042Q Chassis*, to locate the chassis grounding screw. To connect the safety ground, complete the following steps:

1. Connect a 16 AWG (1.3 mm) wire to the chassis grounding screw using a grounding lug. The wire must have green insulation with a yellow stripe or must be noninsulated (bare).
2. Attach the opposite end of the wire to permanent earth ground using toothed washers or a toothed lug.

Connecting to Power Source



Caution Do *not* install modules prior to performing the following power-on test.

Attach input power through the rear AC inlet using the appropriate AC power cable supplied. Refer to Figure 1-2, *Rear View of the PXI-1042 Chassis*, and Figure 1-3, *Rear View of the PXI-1042Q Chassis*, to locate the AC inlet.

The power switch allows you to power on the chassis or place it in standby mode. Push the power switch to the On (recessed) position (if not already on). Observe that all fans become operational and the power switch LED is a steady green.



Caution To remove power, you *must* disconnect the AC power cable.

Installing a PXI Controller

This section contains general installation instructions for installing a PXI controller in a PXI-1042 Series chassis. Refer to your PXI controller user manual for specific instructions and warnings. To install a controller, complete the following steps:

1. Plug in the PXI chassis before installing the controller. The power cord grounds the chassis and protects it from electrical damage while you install the controller. Make sure the power switch is in the Off (standby) position.



Caution To protect both yourself and the chassis from electrical hazards, leave the chassis off until you finish installing the controller.

2. Install the controller into the system controller slot (red card guides) by first placing the controller edges into the front controller guides (top and bottom). Slide the controller to the rear of the chassis (making sure that the injector/ejector handle is pushed down as shown in Figure 2-2).

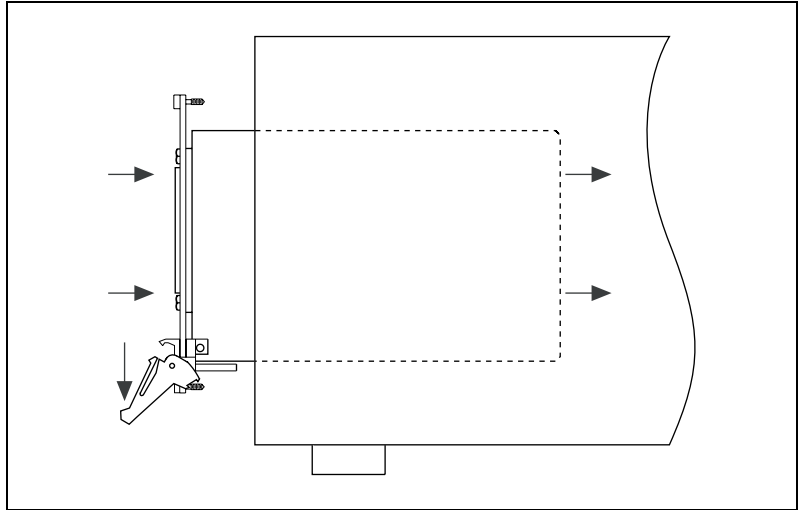

Figure 2-2. Injector/Ejector Handle Position during Controller Insertion

3. When you begin to feel resistance, push up on the injector/ejector handle to inject the controller fully into the chassis frame. Secure the controller front panel to the chassis using the controller front-panel mounting screws.
4. Connect the keyboard, mouse, and monitor to the appropriate connectors. Connect devices to ports as required by your system configuration.
5. Power on the chassis. Verify that the controller boots. If the controller does not boot, refer to your controller user manual.

Figure 2-3 shows a PXI controller installed in the system controller slot of a PXI-1042 chassis. You can place CompactPCI or PXI modules in any other slot.

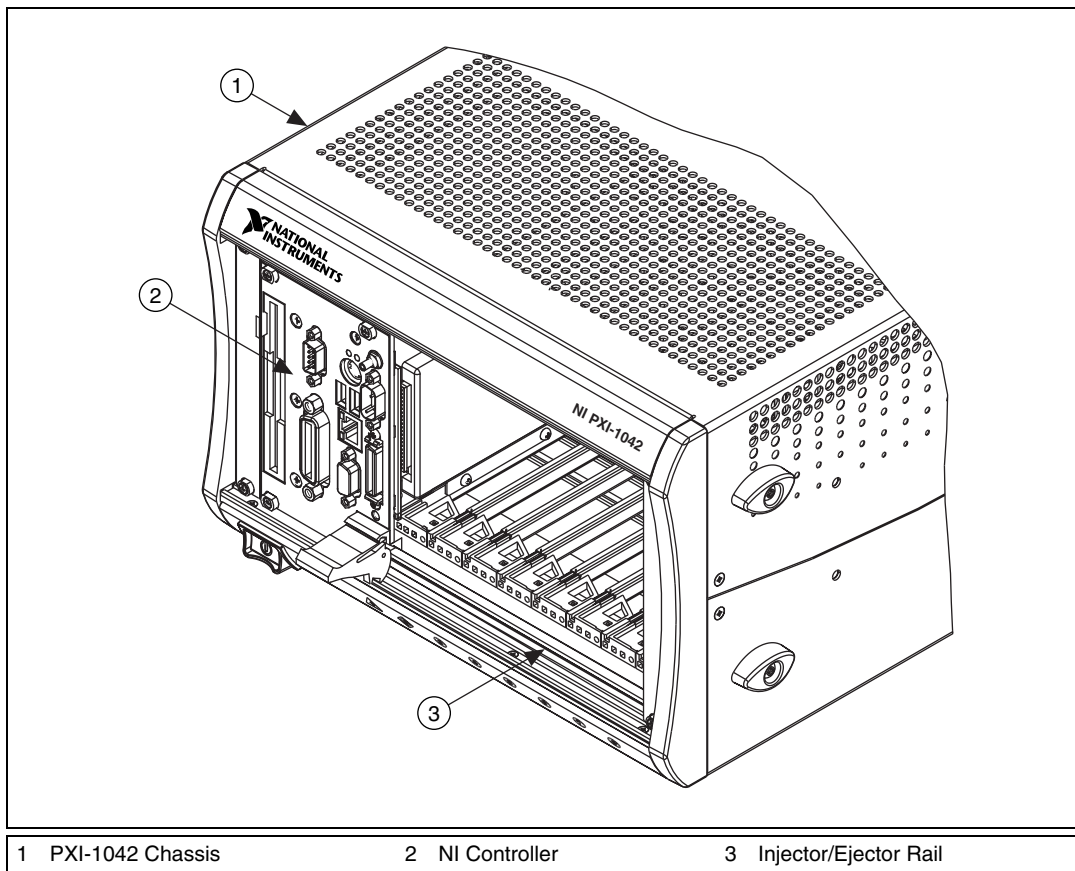

Figure 2-3. NI Controller Installed in a PXI-1042 Chassis

Installing PXI Modules



Caution Disconnect the AC power cable before installing CompactPCI or PXI modules.

To install a module, complete the following steps:

1. Install a module into a chassis slot by first placing the module card edges into the front module guides (top and bottom), as shown in Figure 2-4. Slide the module to the rear of the chassis, making sure that the injector/ejector handle is pushed down as shown in Figure 2-2.
2. When you begin to feel resistance, push up on the injector/ejector handle to fully inject the module into the chassis frame. Secure the

module front panel to the chassis using the module front-panel mounting screws.

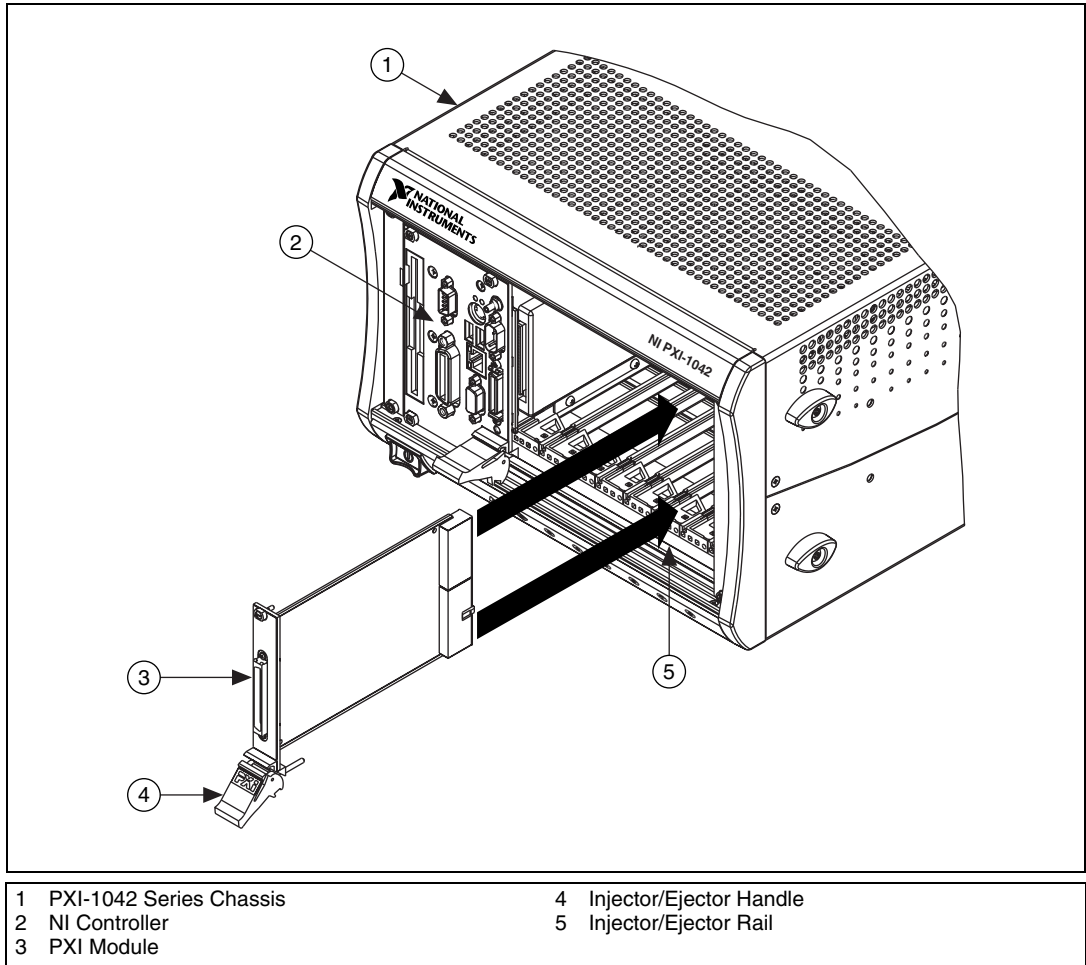

Figure 2-4. Installing PXI or CompactPCI Modules

Power Switch LED Indicator

The chassis power switch has an integrated LED. This LED indicates one of three different conditions:

- If the power switch LED is steady green (not flashing), the chassis is powered on and operating normally.
- If the power switch LED is flashing green, the air-intake temperature has exceeded the chassis operating range.
- If the power switch LED is flashing red, the power supply outputs are not within voltage regulation requirements.

Remote Voltage Monitoring and Control

The PXI-1042 Series chassis support remote voltage monitoring and inhibiting through a male 9-pin D-SUB (DB-9) connector located on the rear panel. Table 2-1 shows the pinout of the 9-pin D-SUB (DB-9) connector.

Table 2-1. Remote Inhibit and Voltage Monitoring Connector Pinout

DB-9 Pin	Signal
1	Logic Ground
2	+5 VDC
3	Reserved
4	+3.3 VDC
5	Inhibit (Active Low)
6	+12 VDC
7	Reserved
8	-12 VDC
9	Logic Ground

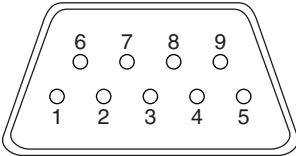

You can use the Inhibit signal (active low) to power off the chassis. To remotely power off the chassis, connect the Inhibit pin (pin 5) to a Logic Ground pin (pin 1 or 9). As long as this connection exists, the chassis will remain off (standby); when you remove this connection, the chassis turns on.



Note For the Inhibit signal to control the On/Off (standby) state of the chassis, the front power switch must be in the On (recessed) position.



Caution When connecting digital voltmeter probes to the rear 9-pin D-SUB (DB-9) connector, be careful not to short the probe leads together. Doing so could damage the power supply.

You can use a digital voltmeter to ensure all voltage levels in the PXI-1042 Series are within the allowable limits. Referring to Table 2-2, connect one lead of the voltmeter to a supply pin on the remote voltage monitoring connector (9-pin D-SUB) on the rear panel. Refer to Table 2-1 for a pinout diagram of the remote voltage monitoring connector. Connect the reference lead of the voltmeter to one of the ground pins. Compare each voltage reading to the values listed in Table 2-2.



Note Use the rear-panel 9-pin D-SUB connector to check voltages only. Do not use the connector to supply power to external devices.

Table 2-2. Power Supply Voltages at Voltage Monitoring Connector (DB-9)

Pin	Supply	Acceptable Voltage Range
2	+5 V	4.75 to 5.25 V
4	+3.3 V	3.135 to 3.465 V
6	+12 V	11.4 to 12.6 V
8	-12 V	-12.6 to -11.4 V
1, 9	Logic Ground	0 V

If the voltages fall within the specified ranges, the chassis complies with the CompactPCI voltage-limit specifications.

PXI_CLK10 Rear Connectors

There are two BNC connectors on the rear of the PXI-1042 Series chassis for PXI_CLK10. The connectors are labeled IN and OUT. You can use them for supplying the backplane with PXI_CLK10 or routing the backplane's PXI_CLK10 to another chassis.

10 MHz REF IN

You can use the 10 MHz REF IN connector to supply an external 10 MHz clock to the backplane. The external clock signal is buffered and provided to each peripheral slot's PXI_CLK10 pin with a maximum slot-to-slot skew of 250 ps. When the backplane detects a 10 MHz signal on the 10 MHz REF IN connector, it automatically overrides the 10 MHz clock provided by the backplane and uses the externally provided clock. If the backplane detects a 10 MHz clock on the PXI_CLK10_IN pin of Slot 2 and a 10 MHz clock on the external 10 MHz REF IN connector, the backplane automatically selects the signal from Slot 2 and provides that signal to each peripheral slot.

The input impedance of the 10 MHz REF IN connector on the rear of the chassis is $50 \Omega \pm 5 \Omega$. The backplane accepts a 10 MHz clock signal between 200 mV_{pp} and 5 V_{pp} and rejects any DC component of the PXI_CLK10 IN signal. The input signal may be a 10 MHz square wave or sine wave.

10 MHz REF OUT

The 10 MHz REF OUT connector provides a buffered non-TTL version of the PXI_CLK10 TTL signal supplied to the peripheral slots on the backplane. You can use this signal to synchronize multiple PXI chassis to the same PXI_CLK10 signal.

The output impedance of this connector is $50 \Omega \pm 5 \Omega$. The output signal is a $1 \text{ V}_{pp} \pm 20\%$ non-TTL square wave.

Using System Configuration and Initialization Files

The PXI specification allows many combinations of PXI chassis and system modules. To assist system integrators, the manufacturers of PXI chassis and system modules must document the capabilities of their products. The minimum documentation requirements are contained in `.ini` files, which consist of ASCII text. System integrators, configuration utilities, and device drivers can use these `.ini` files.

The capability documentation for the PXI-1042 Series chassis is contained in the `chassis.ini` file on the software media that comes with the chassis. The information in this file is combined with information about the system controller to create a single system initialization file called `pxisys.ini` (PXI System Initialization). The system controller manufacturer either provides a `pxisys.ini` file for the particular chassis model that contains the system controller or provides a utility that can read an arbitrary `chassis.ini` file and generate the corresponding `pxisys.ini` file. System controllers from NI provide the `pxisys.ini` file for the PXI-1042 Series chassis, so you should not need to use the `chassis.ini` file. Refer to the documentation provided with the system controller or to ni.com/support for more information on `pxisys.ini` and `chassis.ini` files.

Device drivers and other utility software read the `pxisys.ini` file to obtain system information. The device drivers should have no need to directly read the `chassis.ini` file. For detailed information regarding initialization files, refer to the PXI specification at www.pxisa.org.

Maintenance

This chapter describes basic maintenance procedures you can perform on the PXI-1042 Series chassis.



Caution Disconnect the power cable prior to servicing a PXI-1042 Series chassis.

Service Interval

Clean the chassis fan filters at a maximum interval of six months. Depending on the amount of use and ambient dust levels in the operating environment, the filters may require more frequent cleaning.

Clean dust from the chassis exterior (and interior) as needed, based on the operating environment. Periodic cleaning increases reliability.

Preparation

The information in this section is designed for use by qualified service personnel. Read the *Read Me First: Safety and Radio-Frequency Interference* document included with your kit before attempting any procedures in this chapter.



Caution Many components within the chassis are susceptible to static discharge damage. Service the chassis only in a static-free environment. Observe standard handling precautions for static-sensitive devices while servicing the chassis. Always wear a grounded wrist strap or equivalent while servicing the chassis.

Cleaning

Cleaning procedures consist of exterior and interior cleaning of the chassis and cleaning the fan filters. Refer to your module user documentation for information on cleaning the individual CompactPCI or PXI modules.



Caution Always disconnect the AC power cable before cleaning or servicing the chassis.

Interior Cleaning

Use a dry, low-velocity stream of air to clean the interior of the chassis.
Use a soft-bristle brush for cleaning around components.

Exterior Cleaning

Clean the exterior surfaces of the chassis with a dry lint-free cloth or a soft-bristle brush. If any dirt remains, wipe with a cloth moistened in a mild soap solution. Remove any soap residue by wiping with a cloth moistened with clear water. Do not use abrasive compounds on any part of the chassis.



Caution Avoid getting moisture inside the chassis during exterior cleaning, especially through the top vents. Use just enough moisture to dampen the cloth.

Do *not* wash the front- or rear-panel connectors or switches. Cover these components while cleaning the chassis.

Do *not* use harsh chemical cleaning agents; they may damage the chassis. Avoid chemicals that contain benzene, toluene, xylene, acetone, or similar solvents.

Cleaning and Replacing the Fan Filters

Dirty fan filters can dramatically affect the cooling performance of a PXI-1042 Series chassis. Clean the filters whenever they become visibly dirty. You can easily remove the chassis air filters from the rear of the chassis by removing the filter retainer. To remove the filter retainer, loosen the retainer screw. The filter cover and retainer are shown in Figure 1-2, [Rear View of the PXI-1042 Chassis](#), and Figure 1-3, [Rear View of the PXI-1042Q Chassis](#).

Clean the fan filters by washing them in a mild soap solution and then vacuuming or blowing air through them. Rinse the filters with water and allow them to dry before reinstalling them on the chassis.

If desired, you can replace the fan filters with part number FF 365-A/30P (pack of 10) from Air Filtration Products, Inc., Tucson, AZ 85705.

Resetting the AC Mains Circuit Breaker

If the PXI-1042 Series is connected to an AC source and encounters an over-current condition, the circuit breaker on the rear panel will trip to prevent damage to the chassis. Complete the following steps to reset the circuit breaker.

1. Set the front-panel power switch to the Off (nonrecessed) position.
2. Disconnect the AC power cable.
3. Depress the circuit breaker to reset it.
4. Reconnect the AC power cable.
5. Set the power switch to the On (recessed) position.

If the circuit breaker trips again, complete the following steps:

1. Press the front-panel power switch to the Off (nonrecessed) position.
2. Disconnect the AC power cable.
3. Remove all modules from the chassis.
4. Complete the procedure described in the [Connecting to Power Source](#) section of Chapter 2, [Installation and Configuration](#). If the power switch LED is not a steady green, contact National Instruments.
5. Verify that the PXI-1042 Series can meet the power requirements of your CompactPCI or PXI modules. Overloading the chassis can cause the breaker to trip. Refer to Appendix A, [Specifications](#).
6. The over-current condition that caused the circuit breaker to trip may be due to a faulty CompactPCI or PXI module. Refer to the documentation supplied with the modules for troubleshooting information.

Replacing the Modular Power Supply

This section describes how to remove, configure, and install the AC power-supply shuttle in the PXI-1042 Series chassis.



Note The AC power supply shuttles for the PXI-1042 and PXI-1042Q chassis are not interchangeable.



Caution Disconnect the power cable prior to replacing the power supply.

Before connecting the power-supply shuttle to a power source, read this section and the *Read Me First: Safety and Radio-Frequency Interference* document included with the kit.

Removal

The PXI-1042 AC power-supply is a replacement part for the PXI-1042 AC chassis. The PXI-1042Q AC power-supply shuttle is a replacement part for the PXI-1042Q AC chassis. Before attempting to replace the power-supply shuttle, verify that there is adequate clearance behind the chassis. Set the power switch on the front panel to the Off (nonrecessed) position and disconnect the power cable from the power-supply shuttle on the back of the chassis. Identify the eight captive screws for the PXI-1042 or the eight SEMS screws for the PXI-1042Q that attach the power-supply shuttle to the chassis. Refer to Figure 1-2, [Rear View of the PXI-1042 Chassis](#), or Figure 1-3, [Rear View of the PXI-1042Q Chassis](#), for the screw locations. Using a Phillips screwdriver, loosen the captive screws. Pull on the two rear handles of the power-supply shuttle to remove it from the back of the chassis.

Installation

Ensure that there is no visible damage to the new power-supply shuttle. Verify that the housing and connector on the new power-supply shuttle have no foreign material inside. Remove the protective cap on the PXI_CLK10 connector. Install the new power-supply shuttle into the opening on the rear of the chassis. Tighten the eight captive screws with a Phillips screwdriver.

Configuration

The fan-speed selector switch is on the rear panel of the power-supply shuttle. Refer to Figure 1-2, *Rear View of the PXI-1042 Chassis*, and Figure 1-3, *Rear View of the PXI-1042Q Chassis*, to locate the fan-speed selector. Select HIGH for maximum cooling performance (recommended) or AUTO for quieter operation. When set to AUTO, air-intake temperature determines the fan speed.

Connecting Safety Ground

Refer to the *Connecting Safety Ground* section of Chapter 2, *Installation and Configuration*.

Connecting to Power Source

Refer to the *Connecting to Power Source* section of Chapter 2, *Installation and Configuration*.

Specifications

This appendix contains specifications for the PXI-1042 Series chassis.

Electrical

AC Input

Input voltage range.....	100 to 240 VAC
Operating voltage range ¹	90 to 264 VAC
Input frequency	50/60 Hz
Operating frequency range ¹	47 to 63 Hz
Input current rating.....	8 A
Over-current protection.....	10 A circuit breaker
Line regulation	
3.3 V.....	<±0.2%
5 V.....	<±0.1%
±12 V	<±0.1%
Efficiency	70% typical
Power disconnect	The AC power cable provides main power disconnect. The front-panel power switch causes the internal chassis power supply to provide DC power to the CompactPCI/PXI backplane. You also can use the rear-panel D-SUB 9-pin connector to control the internal chassis power supply.

¹ The operating range is guaranteed by design.

DC Output

DC current capacity (I_{MP})

Voltage	PXI-1042		PXI-1042Q
	0–50 °C	0–55 °C	0–40 °C
+3.3 V	20 A	18 A	20 A
+5 V	29 A	25 A	29 A
+12 V Peripheral slots	3.5 A	3.5 A	3.5 A
+12 V System slot	0.5 A	0.5 A	0.5 A
–12 V	2 A	2 A	2 A

Load regulation

Voltage	Load Regulation
+3.3 V	<5%
+12 V	<5%
+5 V	<5%
–12 V	<5%

Maximum ripple and noise (20 MHz bandwidth)

Voltage	Maximum Ripple and Noise
+3.3 V	50 mV _{pp}
+12 V	120 mV _{pp}
+5 V	50 mV _{pp}
–12 V	120 mV _{pp}

Over-current protection.....	All outputs protected from short circuit and overload with automatic recovery
Over-voltage protection	
3.3 V and 5 V	Clamped at 20 to 30% above nominal output voltage
+12 V and -12 V.....	Clamped at 26 to 29 V difference between +12 and -12 V outputs
Power-supply shuttle MTTR.....	Replacement in under 5 minutes

Chassis Cooling

Per slot cooling capacity	25 W
Module cooling system	
PXI-1042.....	Forced air circulation (positive pressurization) through two 60 cfm fans with HIGH/AUTO speed selector
PXI-1042Q.....	Forced air circulation (positive pressurization) through two 51 cfm fans with HIGH/AUTO speed selector
Slot airflow direction	P1 to P2, bottom of module to top of module
Module cooling intake	Bottom rear of chassis
Module cooling exhaust	Along both sides and top of chassis
Power supply cooling system.....	Forced air circulation through integrated fan
Power supply cooling intake	Right side of chassis
Power supply cooling exhaust.....	Left side of chassis

Environmental

Operating location	Indoor use
Maximum altitude.....	2,000 m (at 25 °C ambient)
Installation Category.....	II
Pollution Degree	2

Operating Environment

Ambient temperature range

PXI-10420 to 55 °C (Tested in accordance with IEC-60068-2-1 and IEC-60068-2-2.)

PXI-1042Q.....0 to 40 °C (Tested in accordance with IEC-60068-2-1 and IEC-60068-2-2.)

Relative humidity range.....10 to 90%, noncondensing (Tested in accordance with IEC-60068-2-56.)

Storage Environment

Ambient temperature range-20 to 70 °C (Tested in accordance with IEC-60068-2-1 and IEC-60068-2-2.)

Relative humidity range.....5 to 95%, noncondensing (Tested in accordance with IEC-60068-2-56.)

Shock and Vibration

Operational shock30 g peak, half-sine, 11 ms pulse (Tested in accordance with IEC-60068-2-27. Test profile developed in accordance with MIL-PRF-28800F.)

Random Vibration

Operating	5 to 500 Hz, 0.3 g _{rms}
Nonoperating.....	5 to 500 Hz, 2.4 g _{rms} (Tested in accordance with IEC-60068-2-64. Nonoperating test profile exceeds the requirements of MIL-PRF-28800F, Class 3.)

Acoustic Emissions

Sound Pressure Level (at Operator Position)

(Tested in accordance with ISO 7779.)

PXI-1042Q

Auto fan (at 25 °C ambient).....	43.4 dBA
High fan	52.9 dBA

PXI-1042

Auto fan (at 25 °C ambient).....	50.5 dBA
High fan	58.7 dBA

Sound Power

(Tested in accordance with ISO 7779.)

PXI-1042Q

Auto fan (at 25 °C ambient).....	52.2 dBA
High fan	62.4 dBA

PXI-1042

Auto fan (at 25 °C ambient).....	58.8 dBA
High fan	67.7 dBA

Safety

The PXI-1042 Series chassis were evaluated using the criteria of EN 61010-1 and meets the requirements of the following standards for safety and electrical equipment for measurement, control, and laboratory use:

- EN 61010-1, IEC 61010-1
- UL 3111-1, UL 61010B-1
- CAN/CSA C22.2 No. 1010.1



Note For UL and other safety certifications, refer to the product label, or visit ni.com/hardref.nsf, search by model number or product line, and click the appropriate link in the Certification column.

Electromagnetic Compatibility

Emissions	EN 55011 Class A at 10 m FCC Part 15A above 1 GHz
Immunity	EN 61326:1997 + A2:2001, Table 1
EMC/EMI	CE, C-Tick, and FCC Part 15 (Class A) Compliant
Harmonics/Flicker	EN 61000-3-2 and EN 61000-3-3



Note For EMC compliance, you *must* operate this device with shielded cabling. In addition, all covers and filler panels must be installed.

CE Compliance

This product meets the essential requirements of applicable European Directives, as amended for CE marking, as follows:

Low-Voltage Directive (safety).....73/23/EEC

Electromagnetic Compatibility
Directive (EMC).....89/336/EEC



Note Refer to the Declaration of Conformity (DoC) for this product for any additional regulatory compliance information. To obtain the DoC for this product, visit ni.com/hardref.nsf, search by model number or product line, and click the appropriate link in the Certification column.

Backplane

Size	3U-sized; one system slot (with three system expansion slots) and seven peripheral slots. Compliant with IEEE 1101.10 mechanical packaging. PXI Specification Revision 2.0 compliant. Accepts both PXI and CompactPCI (PICMG 2.0 R 3.0) 3U modules.
Backplane bare-board material	UL 94 V-0 Recognized
Backplane connectors	Conforms to IEC 917 and IEC 1076-4-101, and are UL 94 V-0 rated

10 MHz System Reference Clock (PXI_CLK10)

Maximum clock skew between slots	250 ps
Built-in 10 MHz clock	
Accuracy	± 25 ppm (guaranteed over the operating temperature range)
Maximum jitter	5 ps RMS in 10 Hz to 1 MHz range
External clock sources	
Connectors	BNC on rear of chassis (ground referenced) or Slot 2 J2 (pin D17; refer to Table B-4, <i>P2 (J2) Connector Pinout for the Star Trigger Slot</i>)
Input frequency	10 MHz ± 100 ppm or better
Input amplitude	
Rear connector	200 mV _{pp} to 5 V _{pp} , 10 MHz squarewave or sinewave
Slot 2	5 V or 3.3 V, 10 MHz TTL signal

Input impedance50 $\Omega \pm 5 \Omega$ (rear connector)
 Maximum jitter introduced
 by backplane circuitry1 ps RMS in 10 Hz to 1 MHz
 range

External clock output

ConnectorBNC on rear of chassis
 (ground-referenced)
 Output amplitude1 V_{pp} $\pm 20\%$ squarewave into 50 Ω
 2 V_{pp} into open circuit
 Output impedance.....50 $\Omega \pm 5 \Omega$

Mechanical

Overall dimensions

Standard chassis

Height6.97 in. (177 mm)
 Width10.68 in. (271.3 mm)
 Depth15.61 in. (396.5 mm)



Note 0.57 in. (14.5 mm) is added to height when feet are installed. When tilted with front feet extended on table top, height is increased approximately 2.08 in. (52.8 mm) in front and 0.583 in. (14.8 mm) in rear.

Weight8.4 kg (18.6 lb)

Chassis materialsSheet Aluminum (5052-H32,
 3003-H14, and 6061-T6),
 Extruded Aluminum (6060-T6),
 and Cold Rolled Steel, PC-ABS,
 Santoprene, Nylon

FinishConductive Clear Iridite
 on Aluminum
 Clear Chromate Zinc Plating
 on Cold Rolled Steel
 Polyurethane Enamel

Figures A-1 and A-2 show the PXI-1042 Series chassis dimensions. The holes shown are for the installation of the optional rack mount kit. You can install this kit on the front or rear of the chassis, depending on which end of the chassis you want to face toward the front of the instrument cabinet. Notice that the front and rear chassis mounting holes (size M4) are symmetrical.

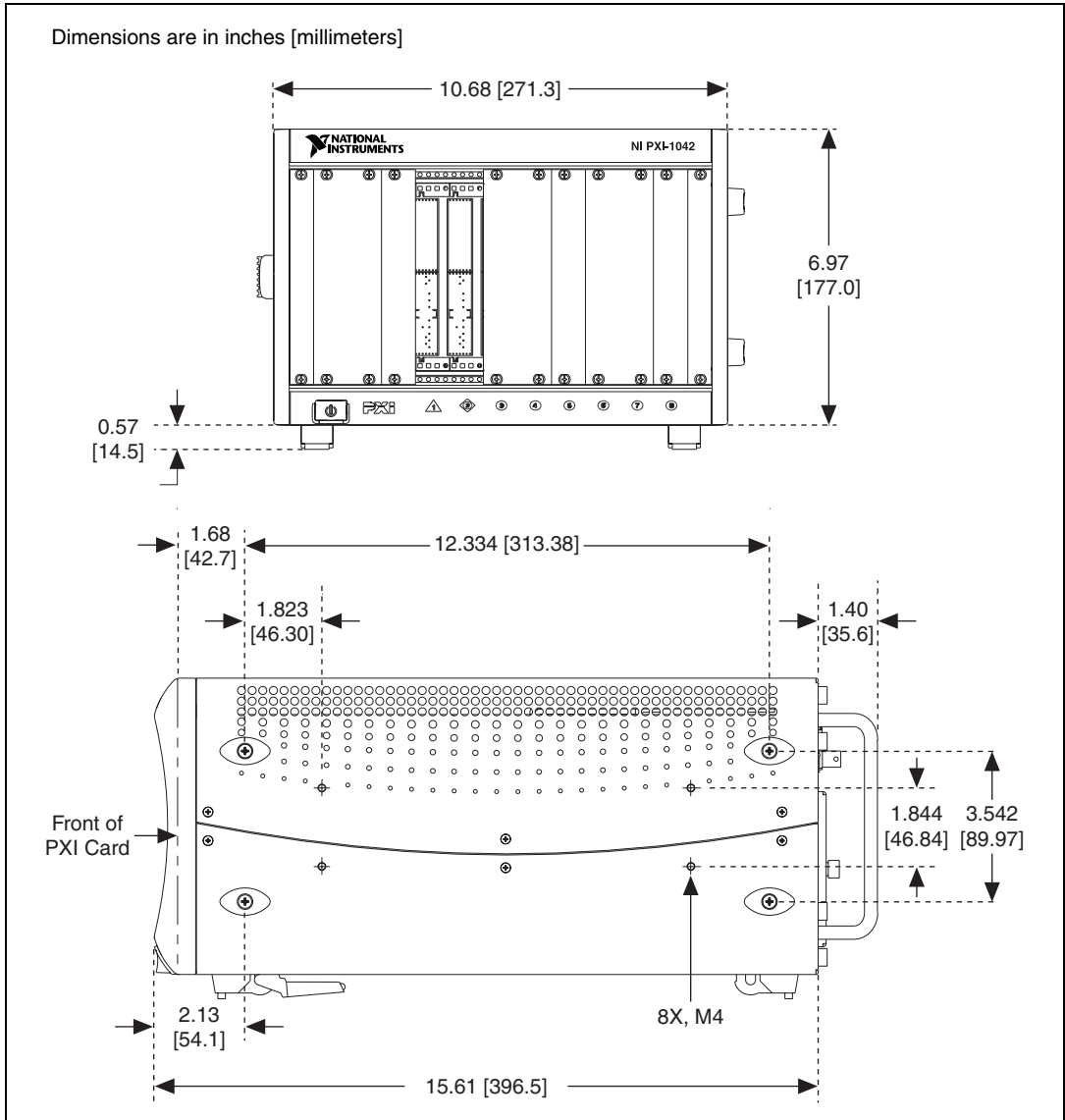

Figure A-1. PXI-1042 Series Chassis Dimensions (Front and Side)

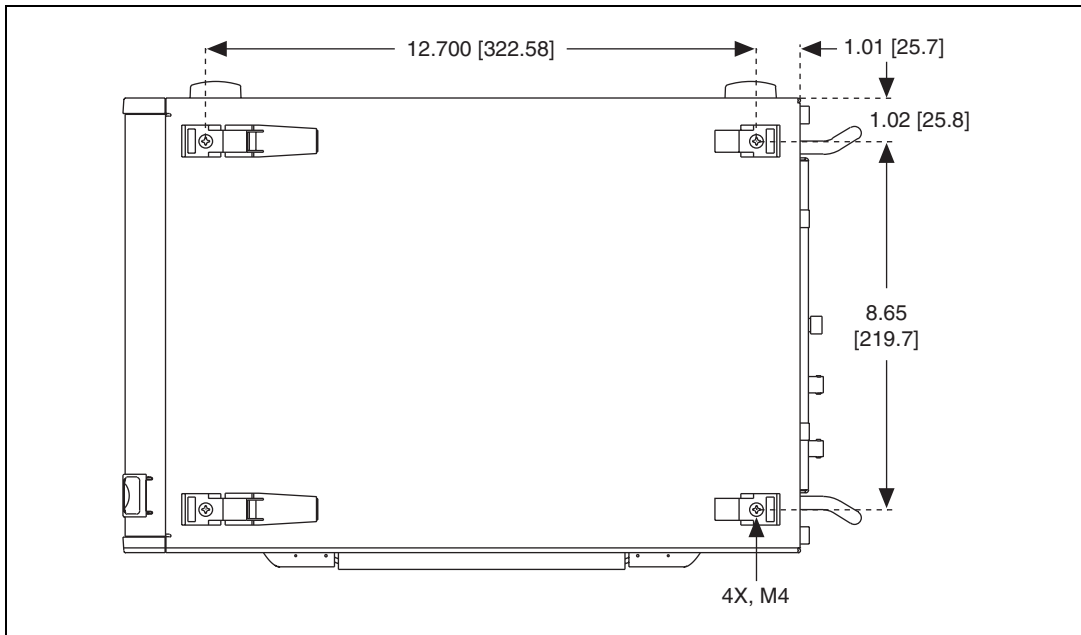

Figure A-2. PXI-1042 Series Chassis Dimensions (Bottom)

Figure A-3 shows the PXI-1042 Series chassis rack mount kit components.

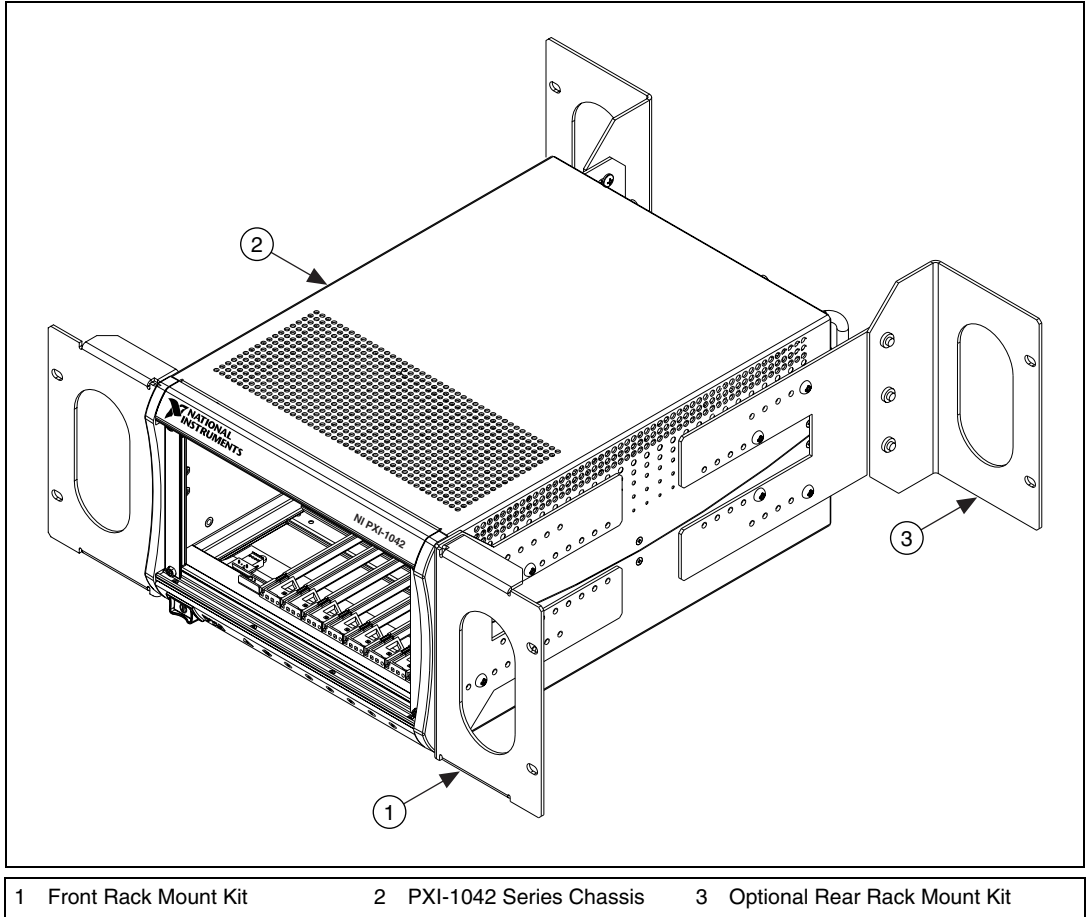

Figure A-3. PXI-1042 Series Chassis Rack Mount Kit Components

Pinouts

This appendix describes the P1 and P2 connector pinouts for the PXI-1042 Series backplane.

Table B-1 shows the P1 (J1) connector pinout for the System Controller slot.

Table B-2 shows the P2 (J2) connector pinout for the System Controller slot.

Table B-3 shows the P1 (J1) connector pinout for the Star Trigger slot.

Table B-4 shows the P2 (J2) connector pinout for the Star Trigger slot.

Table B-5 shows the P1 (J1) connector pinout for the peripheral slots.

Table B-6 shows the P2 (J2) connector pinout for the peripheral slots.



Note PXI signals are shown in boldface.

For more detailed information, refer to the *PXI Specification, Revision 2.0*. Contact the PXI Systems Alliance for a copy of the specification.

Table B-1. P1 (J1) Connector Pinout for the System Controller Slot

Pin	Z	A	B	C	D	E	F
25	GND	5V	REQ64#	ENUM#	3.3V	5V	GND
24	GND	AD[1]	5V	V(I/O)	AD[0]	ACK64#	GND
23	GND	3.3V	AD[4]	AD[3]	5V	AD[2]	GND
22	GND	AD[7]	GND	3.3V	AD[6]	AD[5]	GND
21	GND	3.3V	AD[9]	AD[8]	M66EN	C/BE[0]#	GND
20	GND	AD[12]	GND	V(I/O)	AD[11]	AD[10]	GND
19	GND	3.3V	AD[15]	AD[14]	GND	AD[13]	GND
18	GND	SERR#	GND	3.3V	PAR	C/BE[1]#	GND
17	GND	3.3V	IPMB_SCL	IPMB_SDA	GND	PERR#	GND
16	GND	DEVSEL#	GND	V(I/O)	STOP#	LOCK#	GND
15	GND	3.3V	FRAME#	IRDY#	GND	TRDY#	GND
12–14	Key Area						
11	GND	AD[18]	AD[17]	AD[16]	GND	C/BE[2]#	GND
10	GND	AD[21]	GND	3.3V	AD[20]	AD[19]	GND
9	GND	C/BE[3]#	GND	AD[23]	GND	AD[22]	GND
8	GND	AD[26]	GND	V(I/O)	AD[25]	AD[24]	GND
7	GND	AD[30]	AD[29]	AD[28]	GND	AD[27]	GND
6	GND	REQ0#	GND	3.3V	CLK0	AD[31]	GND
5	GND	BRSVP1A5	BRSVP1B5	RST#	GND	GNT0#	GND
4	GND	IPMB_PWR	HEALTHY	V(I/O)	INTP	INTS	GND
3	GND	INTA#	INTB#	INTC#	5V	INTD#	GND
2	GND	TCK	5V	TMS	TDO	TDI	GND
1	GND	5V	–12V	TRST#	+12V	5V	GND

Table B-2. P2 (J2) Connector Pinout for the System Controller Slot

Pin	Z	A	B	C	D	E	F
22	GND	GA4	GA3	GA2	GA1	GA0	GND
21	GND	CLK6	GND	RSV	RSV	RSV	GND
20	GND	CLK5	GND	RSV	GND	RSV	GND
19	GND	GND	GND	SMB_SDA	SMB_SCL	SMB_ALERT#	GND
18	GND	PXI_TRIG3	PXI_TRIG4	PXI_TRIG5	GND	PXI_TRIG6	GND
17	GND	PXI_TRIG2	GND	PRST#	REQ6#	GNT6#	GND
16	GND	PXI_TRIG1	PXI_TRIG0	DEG#	GND	PXI_TRIG7	GND
15	GND	PXI_BRSVA15	GND	FAL#	REQ5#	GNT5#	GND
14	GND	AD[35]	AD[34]	AD[33]	GND	AD[32]	GND
13	GND	AD[38]	GND	V(I/O)	AD[37]	AD[36]	GND
12	GND	AD[42]	AD[41]	AD[40]	GND	AD[39]	GND
11	GND	AD[45]	GND	V(I/O)	AD[44]	AD[43]	GND
10	GND	AD[49]	AD[48]	AD[47]	GND	AD[46]	GND
9	GND	AD[52]	GND	V(I/O)	AD[51]	AD[50]	GND
8	GND	AD[56]	AD[55]	AD[54]	GND	AD[53]	GND
7	GND	AD[59]	GND	V(I/O)	AD[58]	AD[57]	GND
6	GND	AD[63]	AD[62]	AD[61]	GND	AD[60]	GND
5	GND	C/BE[5]#	GND	V(I/O)	C/BE[4]#	PAR64	GND
4	GND	V(I/O)	PXI_BRSVB4	C/BE[7]#	GND	C/BE[6]#	GND
3	GND	CLK4	GND	GNT3#	REQ4#	GNT4#	GND
2	GND	CLK2	CLK3	SYSEN#	GNT2#	REQ3#	GND
1	GND	CLK1	GND	REQ1#	GNT1#	REQ2#	GND

Table B-3. P1 (J1) Connector Pinout for the Star Trigger Slot

Pin	Z	A	B	C	D	E	F
25	GND	5V	REQ64#	ENUM#	3.3V	5V	GND
24	GND	AD[1]	5V	V(I/O)	AD[0]	ACK64#	GND
23	GND	3.3V	AD[4]	AD[3]	5V	AD[2]	GND
22	GND	AD[7]	GND	3.3V	AD[6]	AD[5]	GND
21	GND	3.3V	AD[9]	AD[8]	M66EN	C/BE[0]#	GND
20	GND	AD[12]	GND	V(I/O)	AD[11]	AD[10]	GND
19	GND	3.3V	AD[15]	AD[14]	GND	AD[13]	GND
18	GND	SERR#	GND	3.3V	PAR	C/BE[1]#	GND
17	GND	3.3V	IPMB_SCL	IPMB_SDA	GND	PERR#	GND
16	GND	DEVSEL#	GND	V(I/O)	STOP#	LOCK#	GND
15	GND	3.3V	FRAME#	IRDY#	BD_SEL#	TRDY#	GND
12–14	Key Area						
11	GND	AD[18]	AD[17]	AD[16]	GND	C/BE[2]#	GND
10	GND	AD[21]	GND	3.3V	AD[20]	AD[19]	GND
9	GND	C/BE[3]#	IDSEL	AD[23]	GND	AD[22]	GND
8	GND	AD[26]	GND	V(I/O)	AD[25]	AD[24]	GND
7	GND	AD[30]	AD[29]	AD[28]	GND	AD[27]	GND
6	GND	REQ#	GND	3.3V	CLK	AD[31]	GND
5	GND	BRSVP1A5	BRSVP1B5	RST#	GND	GNT#	GND
4	GND	IPMB_PWR	HEALTHY	V(I/O)	INTP	INTS	GND
3	GND	INTA#	INTB#	INTC#	5V	INTD#	GND
2	GND	TCK	5V	TMS	TDO	TDI	GND
1	GND	5V	-12V	TRST#	+12V	5V	GND

Table B-4. P2 (J2) Connector Pinout for the Star Trigger Slot

Pin	Z	A	B	C	D	E	F
22	GND	GA4	GA3	GA2	GA1	GA0	GND
21	GND	PXI_LBR0	GND	PXI_LBR1	PXI_LBR2	PXI_LBR3	GND
20	GND	PXI_LBR4	PXI_LBR5	PXI_STAR0	GND	PXI_STAR1	GND
19	GND	PXI_STAR2	GND	PXI_STAR3	PXI_STAR4	PXI_STAR5	GND
18	GND	PXI_TRIG3	PXI_TRIG4	PXI_TRIG5	GND	PXI_TRIG6	GND
17	GND	PXI_TRIG2	GND	RSV	PXI_CLK10_IN	PXI_CLK10	GND
16	GND	PXI_TRIG1	PXI_TRIG0	RSV	GND	PXI_TRIG7	GND
15	GND	PXI_BRSVA15	GND	RSV	PXI_STAR6	PXI_LBR6	GND
14	GND	AD[35]	AD[34]	AD[33]	GND	AD[32]	GND
13	GND	AD[38]	GND	V(I/O)	AD[37]	AD[36]	GND
12	GND	AD[42]	AD[41]	AD[40]	GND	AD[39]	GND
11	GND	AD[45]	GND	V(I/O)	AD[44]	AD[43]	GND
10	GND	AD[49]	AD[48]	AD[47]	GND	AD[46]	GND
9	GND	AD[52]	GND	V(I/O)	AD[51]	AD[50]	GND
8	GND	AD[56]	AD[55]	AD[54]	GND	AD[53]	GND
7	GND	AD[59]	GND	V(I/O)	AD[58]	AD[57]	GND
6	GND	AD[63]	AD[62]	AD[61]	GND	AD[60]	GND
5	GND	C/BE[5]#	GND	V(I/O)	C/BE[4]#	PAR64	GND
4	GND	V(I/O)	PXI_BRSVB4	C/BE[7]#	GND	C/BE[6]#	GND
3	GND	PXI_LBR7	GND	PXI_LBR8	PXI_LBR9	PXI_LBR10	GND
2	GND	PXI_LBR11	PXI_LBR12	UNC	PXI_STAR7	PXI_STAR8	GND
1	GND	PXI_STAR9	GND	PXI_STAR10	PXI_STAR11	PXI_STAR12	GND

Table B-5. P1 (J1) Connector Pinout for the Peripheral Slot

Pin	Z	A	B	C	D	E	F
25	GND	5V	REQ64#	ENUM#	3.3V	5V	GND
24	GND	AD[1]	5V	V(I/O)	AD[0]	ACK64#	GND
23	GND	3.3V	AD[4]	AD[3]	5V	AD[2]	GND
22	GND	AD[7]	GND	3.3V	AD[6]	AD[5]	GND
21	GND	3.3V	AD[9]	AD[8]	M66EN	C/BE[0]#	GND
20	GND	AD[12]	GND	V(I/O)	AD[11]	AD[10]	GND
19	GND	3.3V	AD[15]	AD[14]	GND	AD[13]	GND
18	GND	SERR#	GND	3.3V	PAR	C/BE[1]#	GND
17	GND	3.3V	IPMB_SCL	IPMB_SDA	GND	PERR#	GND
16	GND	DEVSEL#	GND	V(I/O)	STOP#	LOCK#	GND
15	GND	3.3V	FRAME#	IRDY#	BD_SEL#	TRDY#	GND
12–14	Key Area						
11	GND	AD[18]	AD[17]	AD[16]	GND	C/BE[2]#	GND
10	GND	AD[21]	GND	3.3V	AD[20]	AD[19]	GND
9	GND	C/BE[3]#	IDSEL	AD[23]	GND	AD[22]	GND
8	GND	AD[26]	GND	V(I/O)	AD[25]	AD[24]	GND
7	GND	AD[30]	AD[29]	AD[28]	GND	AD[27]	GND
6	GND	REQ#	GND	3.3V	CLK	AD[31]	GND
5	GND	BRSVP1A5	BRSVP1B5	RST#	GND	GNT#	GND
4	GND	IPMB_PWR	HEALTHY	V(I/O)	INTP	INTS	GND
3	GND	INTA#	INTB#	INTC#	5V	INTD#	GND
2	GND	TCK	5V	TMS	TDO	TDI	GND
1	GND	5V	-12V	TRST#	+12V	5V	GND

Table B-6. P2 (J2) Connector Pinout for the Peripheral Slot

Pin	Z	A	B	C	D	E	F
22	GND	GA4	GA3	GA2	GA1	GA0	GND
21	GND	PXI_LBR0	GND	PXI_LBR1	PXI_LBR2	PXI_LBR3	GND
20	GND	PXI_LBR4	PXI_LBR5	PXI_LBL0	GND	PXI_LBL1	GND
19	GND	PXI_LBL2	GND	PXI_LBL3	PXI_LBL4	PXI_LBL5	GND
18	GND	PXI_TRIG3	PXI_TRIG4	PXI_TRIG5	GND	PXI_TRIG6	GND
17	GND	PXI_TRIG2	GND	RSV	PXI_STAR	PXI_CLK10	GND
16	GND	PXI_TRIG1	PXI_TRIG0	RSV	GND	PXI_TRIG7	GND
15	GND	PXI_BRSVA15	GND	RSV	PXI_LBL6	PXI_LBR6	GND
14	GND	AD[35]	AD[34]	AD[33]	GND	AD[32]	GND
13	GND	AD[38]	GND	V(I/O)	AD[37]	AD[36]	GND
12	GND	AD[42]	AD[41]	AD[40]	GND	AD[39]	GND
11	GND	AD[45]	GND	V(I/O)	AD[44]	AD[43]	GND
10	GND	AD[49]	AD[48]	AD[47]	GND	AD[46]	GND
9	GND	AD[52]	GND	V(I/O)	AD[51]	AD[50]	GND
8	GND	AD[56]	AD[55]	AD[54]	GND	AD[53]	GND
7	GND	AD[59]	GND	V(I/O)	AD[58]	AD[57]	GND
6	GND	AD[63]	AD[62]	AD[61]	GND	AD[60]	GND
5	GND	C/BE[5]#	GND	V(I/O)	C/BE[4]#	PAR64	GND
4	GND	V(I/O)	PXI_BRSVB4	C/BE[7]#	GND	C/BE[6]#	GND
3	GND	PXI_LBR7	GND	PXI_LBR8	PXI_LBR9	PXI_LBR10	GND
2	GND	PXI_LBR11	PXI_LBR12	UNC	PXI_LBL7	PXI_LBL8	GND
1	GND	PXI_LBL9	GND	PXI_LBL10	PXI_LBL11	PXI_LBL12	GND



Technical Support and Professional Services

Visit the following sections of the National Instruments Web site at ni.com for technical support and professional services:

- **Support**—Online technical support resources at ni.com/support include the following:
 - **Self-Help Resources**—For immediate answers and solutions, visit the award-winning National Instruments Web site for software drivers and updates, a searchable KnowledgeBase, product manuals, step-by-step troubleshooting wizards, thousands of example programs, tutorials, application notes, instrument drivers, and so on.
 - **Free Technical Support**—All registered users receive free Basic Service, which includes access to hundreds of Application Engineers worldwide in the NI Developer Exchange at ni.com/exchange. National Instruments Application Engineers make sure every question receives an answer.
- **Training and Certification**—Visit ni.com/training for self-paced training, eLearning virtual classrooms, interactive CDs, and Certification program information. You also can register for instructor-led, hands-on courses at locations around the world.
- **System Integration**—If you have time constraints, limited in-house technical resources, or other project challenges, NI Alliance Program members can help. To learn more, call your local NI office or visit ni.com/alliance.
- **Declaration of Conformity (DoC)**—A DoC is our claim of compliance with the Council of the European Communities using the manufacturer's declaration of conformity. This system affords the user protection for electronic compatibility (EMC) and product safety. You can obtain the DoC for your product by visiting ni.com/hardref.nsf.
- **Calibration Certificate**—If your product supports calibration, you can obtain the calibration certificate for your product at ni.com/calibration.

If you searched ni.com and could not find the answers you need, contact your local office or NI corporate headquarters. Phone numbers for our worldwide offices are listed at the front of this manual. You also can visit the Worldwide Offices section of ni.com/niglobal to access the branch office Web sites, which provide up-to-date contact information, support phone numbers, email addresses, and current events.

Glossary

Symbol	Prefix	Value
p	pico	10^{-12}
n	nano	10^{-9}
μ	micro	10^{-6}
m	milli	10^{-3}
k	kilo	10^3
M	mega	10^6
G	giga	10^9
T	tera	10^{12}

Symbols

°	Degrees.
\geq	Equal or greater than.
\leq	Equal or less than.
%	Percent.

A

A	Amperes.
AC	Alternating current.
ANSI	American National Standards Institute.
AUTO	Automatic fan speed control.
AWG	American Wire Gauge.

B

backplane	An assembly, typically a printed circuit board, with connectors and signal paths that bus the connector pins.
BNC	Bayonet Neill Concelman connector; a commonly used coaxial connector.

C

C	Celsius.
cfm	Cubic feet per minute.
CFR	Code of Federal Regulations.
cm	Centimeters.
CompactPCI	An adaptation of the Peripheral Component Interconnect (PCI) Specification 2.1 or later for industrial and/or embedded applications requiring a more robust mechanical form factor than desktop PCI. It uses industry standard mechanical components and high-performance connector technologies to provide an optimized system intended for rugged applications. It is electrically compatible with the PCI Specification, which enables low-cost PCI components to be utilized in a mechanical form factor suited for rugged environments.
CSA	Canadian Standards Association.

D

daisy-chain	A method of propagating signals along a bus, in which the devices are prioritized on the basis of their position on the bus.
DB-9	A 9-pin D-SUB connector.
DC	Direct current.
DoC	Declaration of Conformity.
D-SUB	Subminiature D connector.

E

efficiency	Ratio of output power to input power, expressed as a percentage.
EIA	Electronic Industries Association.
EMC	Electromagnetic Compatibility.
EMI	Electromagnetic Interference.

F

FCC	Federal Communications Commission.
filler panel	A blank module front panel used to fill empty slots in the chassis.

G

g	(1) grams; (2) a measure of acceleration equal to 9.8 m/s ² .
GPIB	General Purpose Interface Bus (IEEE 488).
g _{RMS}	A measure of random vibration. The root mean square of acceleration levels in a random vibration test profile.

H

hr	Hours.
Hz	Hertz; cycles per second.

I

IEC	International Electrotechnical Commission; an organization that sets international electrical and electronics standards.
IEEE	Institute of Electrical and Electronics Engineers.
I _{MP}	Mainframe peak current.

in. Inches.

inhibit To turn off.

J

jitter A measure of the small, rapid variations in clock transition times from their nominal regular intervals. Units: seconds RMS.

K

kg Kilograms.

km Kilometers.

L

lb Pounds.

LED Light emitting diode.

line regulation The maximum steady-state percentage that a DC voltage output will change as a result of a specified change in input AC voltage (step change from 90 to 132 VAC or 180 to 264 VAC).

load regulation The maximum steady-state percentage that a DC voltage output will change as a result of a step change from no-load to full-load output current.

M

m Meters.

MHz Megahertz. One million Hertz; one Hertz equals one cycle per second.

mi Miles.

ms Milliseconds.

MTBF Mean time between failure.

MTTR Mean time to repair.

N

NEMA National Electrical Manufacturers Association.

NI National Instruments.

P

power-supply shuttle A removable module that contains the chassis power supply.

PXI PCI eXtensions for Instrumentation.

PXI_CLK10 10 MHz PXI system reference clock.

R

RH Relative humidity.

RMS Root mean square.

S

s Seconds.

skew Deviation in signal transmission times.

slot blocker An assembly installed into an empty slot to improve the airflow in adjacent slots.

ST Star Trigger.

standby The backplane is unpowered (off), but the chassis is still connected to AC power mains.

Star Trigger slot This slot is located at Slot 2 and has a dedicated trigger line between each peripheral slot. Use this slot for a module with ST functionality that can provide individual triggers to all other peripherals.

System controller	A module configured for installation in Slot 1 of a PXI chassis. This device is unique in the PXI system in that it performs the system controller functions, including clock sourcing and arbitration for data transfers across the backplane. Installing such a device into any other slot can damage the device, the PXI backplane, or both.
system reference clock	A 10 MHz clock, also called PXI_CLK10, that is distributed to all peripheral slots in the chassis, as well as a BNC connector on the rear of chassis labeled <i>10 MHz REF OUT</i> . The system reference clock can be used for synchronization of multiple modules in a measurement or control system. The 10 MHz REF IN and OUT BNC connectors on the rear of the chassis can be used to synchronize multiple chassis to one reference clock. The PXI backplane specification defines implementation guidelines for PXI_CLK10.

T

TTL	Transistor-transistor logic.
-----	------------------------------

U

UL	Underwriter's Laboratories.
----	-----------------------------

V

V	Volts.
VAC	Volts alternating current.
V_{pp}	Peak-to-peak voltage.

W

W	Watts.
---	--------

Index

A

AC power cables (table), 1-2

B

backplane

- interoperability with CompactPCI, 1-6
- local bus, 1-7
- overview, 1-6
- peripheral slots, 1-7
- specifications, A-7
- star trigger (ST) slot, 1-7
- system reference clock, 1-8
- trigger bus, 1-8

C

- cables, power (table), 1-2
- calibration certificate (NI resources), C-1
- CE compliance specifications, A-6
- chassis initialization file, 2-11
- CLK10 rear connectors, 2-10
- CompactPCI
 - installing modules (figure), 2-7
 - interoperability with PXI-1042 backplane, 1-6
- configuration. *See* installation, configuration, and operation
- connector pinouts. *See* pinouts
- conventions used in the manual, *vii*
- cooling
 - air cooling of PXI-1042 series, 2-1
 - air intake (figure), 2-2
 - filler panel installation, 2-2
 - setting fan speed, 2-2
 - slot blocker installation, 2-3

D

- DB-9 connector
 - pinout (table), 2-8
 - power supply voltages (table), 2-9
- Declaration of Conformity (NI resources), C-1
- diagnostic tools (NI resources), C-1
- dimensions (figure), A-9, A-10
- documentation
 - conventions used in manual, *vii*
 - NI resources, C-1
 - related documentation, *viii*
- drivers (NI resources), C-1

E

- electromagnetic compatibility, A-6
- EMC filler panel kit, 1-5
- examples (NI resources), C-1

F

- fan, setting speed, 2-2
- filler panel installation, 2-2

G

- ground, connecting, 2-3

H

- help, technical support, C-1

I

- IEC 320 inlet, 1-4, 1-5, 2-4
- installation, configuration, and operation
 - chassis initialization file, 2-11
 - connecting safety ground, 2-3
 - filler panel installation, 2-2
 - installing a PXI controller, 2-4
 - module installation, 2-5, 2-6
 - CompactPCI or PXI modules (figure), 2-7
 - injector/ejector handle position (figure), 2-5
 - PXI controller installed in a PXI-1042 series chassis (figure), 2-6
 - rack mounting, 2-3
 - remote voltage monitoring and inhibiting interface, 2-8
 - setting fan speed, 2-2
 - site considerations, 2-1
 - slot blocker installation, 2-3
 - testing power up, 2-4
 - unpacking the PXI-1042 series, 1-1
- instrument drivers (NI resources), C-1
- interoperability with CompactPCI, 1-6

K

- key features, 1-2
- kit contents, 1-1
- KnowledgeBase, C-1

L

- local bus, routing (figure), 1-7, 1-8

M

- maintenance of PXI-1042 series, 3-1
 - cleaning
 - exterior cleaning, 3-2
 - fan filters, 3-1, 3-2
 - interior cleaning, 3-2
 - preparation, 3-1
 - resetting the AC mains circuit breaker, 3-3
 - service interval, 3-1
 - static discharge damage (caution), 3-1

N

- National Instruments support and services, C-1
- NI support and services, C-1

O

- optional equipment, 1-5

P

- P1 (J1) connector
 - peripheral slot (table), B-6
 - Star Trigger slot (table), B-4
 - system controller slot (table), B-2
- P2 (J2) connector
 - peripheral slot (table), B-7
 - Star Trigger slot (table), B-5
 - system controller slot (table), B-3

- peripheral slots
 - overview, 1-7
 - P1 (J1) connector pinouts (table), B-6
 - P2 (J2) connector pinouts (table), B-7
 - pinouts, B-1
 - DB-9 connector (table), 2-8
 - P1 (J1) connector
 - peripheral slot (table), B-6
 - Star Trigger slot (table), B-4
 - system controller slot (table), B-2
 - P2 (J2) connector
 - peripheral slot (table), B-7
 - Star Trigger slot (table), B-5
 - system controller slot (table), B-3
 - power cables (table), 1-2
 - power supply
 - connecting to, 2-4
 - remote voltage monitoring and inhibiting interface, 2-8
 - replacing
 - configuration, 3-5
 - connecting safety ground, 3-5
 - connecting to power source, 3-5
 - installation, 3-4
 - removal, 3-4
 - voltages at voltage monitoring connector (DB-9) (table), 2-8
 - power switch LED indicator, 2-8
 - power up, testing, 2-4
 - programming examples (NI resources), C-1
 - PXI controller, 2-4
 - installing in a PXI-1042 chassis (figure), 2-6
 - PXI_CLK10, 1-8
 - PXI_CLK10_IN pin, 1-8
 - PXI-1042 series
 - cooling air intake (figure), 2-2
 - fan speed, setting, 2-2
 - front view (figure), 1-3
 - installation. *See* installation, configuration, and operation
 - key features, 1-2
 - maintenance. *See* maintenance of PXI-1042 series
 - optional equipment, 1-5
 - rack mount kits, 1-5
 - rack mounting, 2-3
 - rear view of pxi-1042 chassis, 1-4
 - rear view of pxi-1042Q chassis, 1-5
 - safety ground, connecting, 2-3
 - unpacking, 1-1
 - PXI-1042 series backplane
 - interoperability with CompactPCI, 1-6
 - local bus, 1-7
 - overview, 1-6
 - peripheral slots, 1-7
 - specifications, A-7
 - star trigger (ST) slot, 1-7
 - system reference clock, 1-8
 - trigger bus, 1-8
- ## R
- rack mount kit dimensions (figure), A-11
 - rack mount kits, 1-5
 - rack mounting, 2-3
 - related documentation, *viii*
 - remote voltage monitoring and inhibiting interface, 2-8
- ## S
- safety ground, connecting, 2-3
 - safety specifications (table), A-6
 - service interval, 3-1
 - setting fan speed, 2-2
 - slot blocker installation, 2-3
 - slot blocker kit, 1-6
 - software (NI resources), C-1

specifications

- acoustic emissions, A-5
 - sound power, A-5
 - sound pressure level (at operator position), A-5
 - backplane, A-7
 - 10 MHz system reference clock (PXI_CLK10), A-7
 - CE compliance, A-6
 - chassis cooling, A-3
 - dimensions (figure), A-9, A-10
 - electrical, A-1
 - AC input, A-1
 - DC output, A-2
 - electromagnetic compatibility, A-6
 - environmental, A-4
 - operating environment, A-4
 - storage environment, A-4
 - mechanical, A-8
 - rack mount kit dimensions (figure), A-11
 - safety, A-6
 - shock and vibration, A-4
 - random vibration, A-5
- Star Trigger (ST) slot
- P1 (J1) connector pinouts (table), B-4
 - P2 (J2) connector pinouts (table), B-5
- star trigger (ST) slot
- description, 1-7
- support, technical, C-1

- system controller slot
 - description, 1-6
 - P1 (J1) connector pinouts (table), B-2
 - P2 (J2) connector pinouts (table), B-3
- system reference clock, 1-8

T

- technical support, C-1
- testing power up, 2-4
- training and certification (NI resources), C-1
- trigger bus, 1-8
- troubleshooting (NI resources), C-1

U

- unpacking the PXI-1042 series, 1-1

V

- voltage monitoring connector. *See* DB-9 connector
- voltages at voltage monitoring connector (DB-9) (table), 2-9

W

- Web resources, C-1