

---

# **Operation Manual**

**Oscilloscope**

**SS-7840**

**IWATSU**

CE



# Introduction

- ◇ Thank you very much for your purchase of Iwatsu's electronic measuring instruments. We appreciate your continued patronage of Iwatsu's electronic measuring instruments.
- ◇ Please use your instrument after thoroughly reading this manual and understanding its contents. After reading this manual, please keep it in a safe place for future reference.
- ◇ This Oscilloscope meets CE requirements per the Council Directive 89/336/EEC for Electromagnetic Compatibility and Low Voltage Directive 73/23/ECC for Product Safety.



## Cautions for safe use

Matters that must be observed for safe operation of this instrument and for prevention of injury to humans and damage to property are described as “⚠ warnings” and “⚠ cautions” in this manual. The symbol to invoke caution is marked on the panel.

### Explanation of “⚠ warnings” and “⚠ cautions” columns in this manual

|  |  |
|--|--|
|  <b>Warning</b>  | Incorrect operation or failure to heed warnings may result in death or serious injury.       |
|  <b>Caution</b> | Incorrect operation or failure to heed cautions may result in injury or damage to equipment. |

### Explanation of the symbols on the panel

|  |  |
|--|--|
|  Warning symbol | This a symbol used in reference with the statements in the manual to protect the user against injury and protect this instrument against damage. |
|                 | Frame or chassis Terminal  |

## Cautions

- ◇ Parts of the contents of this manual may be modified without notice to accommodate improvements in performance and function.
- ◇ Reproduction of the contents of this manual without previous consent is prohibited.

## History

- ◇ Oct. 2003 : 3rd edition
- ◇ April 2005 : 4th edition
- ◇ Feb. 2006 : 5th edition

## Warnings

### **Do not use this instrument in a location where there is explosive gas in the vicinity.**

The use of this instrument in a location where there is explosive gas could result in explosion.

### **If there is any smoke, abnormal odor, or abnormal sound coming from this instrument, immediately set the power switch to STBY and disconnect the power cord.**

Use of this instrument under these conditions could result in electrical shock or fire. After setting the power switch to STBY and disconnecting the power cord, contact our office or our sales distributors for repair. Repair by the user is dangerous and should be strictly avoided.

### **Take care to not allow water to get into this instrument or the wetting of this instrument.**

The use of this instrument in a wet state could result in electrical shock or fire. If water or other foreign matter has gotten into this instrument, first set the power switch to STBY and remove the power cord and then contact our office or our sales distributors for repair.

### **Do not place this instrument on an unstable place such as on a shaky stand or on a slant.**

The dropping or turning over of this instrument could result in electrical shock, injury, or fire. If this instrument has dropped or its cover has been damaged, first set the power switch to STBY and remove the power cord and then contact our office or our sales distributors for repair.

### **Do not allow any foreign matter such as metal or inflammable substance to get in from the air hole, etc.**

The entrance of any foreign matter from the ventilation port, etc., could result in fire, electrical shock, or power failure. If any foreign matter has entered, first set the power switch to STBY and remove the power cord and then contact our office or our sales distributors for repair.

Be sure to read this page to assure safety. Read the next page also.

## Warnings (cont'd)

### Be sure to use a 3-core power cord.

Failure to use a 3-core power cord could result in electrical shock or power failure.

- When supplying power from a 2-wire receptacle using a 3-core/2-core conversion adapter, be sure to connect the grounding terminal of the 3-core/2-core conversion adapter to ground.
- When supplying power from a 3-wire receptacle using the attached 3-core power cord, the grounding wire of the power cord is connected to ground.

### Use this instrument with the rated AC ( ~ ) power supply.

Use of this instrument with a voltage other than specified could result in electrical shock, fire, or power failure. The usable power voltage range (100 to 240 VAC) is marked on the rear panel.

### Be sure to connect the ground side of probes and input connectors to the grounding potential of the object being measured.

If the grounding lead is connected to potential other than the ground, electrical shock or other accidents (damages to the object being measured, the instrument itself or other units connected to the instrument) may occur (refer to the "Example of improper configuration" shown below).

[Example of improper configuration]

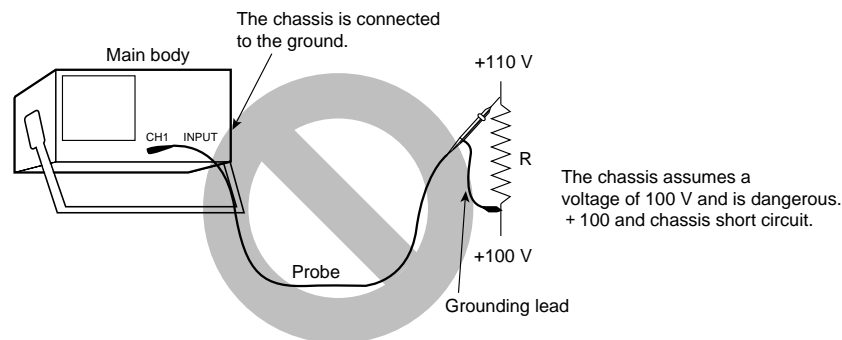

When measuring the floating potential, measurement by the differential method (CH1 and CH2 input) is recommended (refer to the example shown below).

[Example of recommended measurement method]

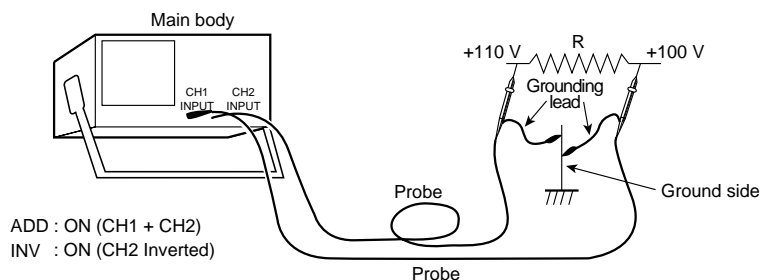

**Be sure to read this page to assure safety.** Read the next page also.

## **Warnings** (cont'd)

### **Do not remove either the cover or panel.**

There are high-voltage parts inside the cover and panel and touching any of them could result in electrical shock. Please contact our office or our sales distributors for any inspection, calibration, or repair.

### **Take sufficient care when measuring high voltages.**

Touching a high-voltage part during measurement could result in electrical shock.

### **When handling the power cord, strictly observe the following:**

Failure to heed this inspection could result in fire or electrical shock. If the power cord has been damaged, contact our office or our sales distributors for repair.

- Do not modify the power cord.
- Do not bend the power cord forcibly.
- Do not twist the power cord.
- Do not bundle the power cord.
- Do not pull the power cord.
- Do not heat the power cord.
- Do not moisten the power cord.
- Do not place a heavy object on the power cord.

### **Do not modify this instrument.**

Modification of this instrument could result in electrical shock, fire, or power failure. Repair of a modified instrument may be refused.

**Be sure to read this page to assure safety.** Read the next page also.

## **Cautions**

**Be sure to use a specified fuse ( 5 x 20 mm, T5 A/250 V) when replacing the fuse.**

The use of a fuse other than a specified one could result in fire or power failure. Disconnect the power cord when replacing the fuse.

**Be sure to use a three-core power cord suitable for the supply voltage.**

The use of a cord that is not suitable for the supply voltage may cause fire. Also, the use of a two-core power cord may cause electrical shock.

**Be sure to connect and disconnect the power cord after setting the power switch to STBY.**

Connection and disconnection of the power cord with power supplied could result in electrical shock or power failure.

**When disconnecting the power cord from the receptacle, pull it by holding the plug.**

Pulling by the cord may damage the cord and could result in fire or electrical shock.

**Avoid use of any damaged cable or adapter.**

The use of any damaged cable or adapter could result in fire or electrical shock.

**Avoid placing any object on this instrument.**

If any object is placed on this instrument, the cover may contact the internal circuitry and could result in electrical shock, fire, or power failure.

**Do not place any object in the vicinity of the air hole or fan of this instrument.**

Placing any object in the vicinity of the air hole or fan may generate internal heat and could result in fire or electrical shock.

**Do not place this instrument in a location with a high degree of moisture or dust.**

Placing this instrument in a location with a high degree of moisture or dust could result in fire or electrical shock.

**When using this instrument in an upright position, take care not to allow it fall over.**

The falling over of this instrument could result in injury, fire, or electrical shock.

**When probes or measuring cables, etc. are connected to this instrument, take care not to cause this instrument to fall over by pulling them.**

The falling over of this instrument could result in injury, fire, or electrical shock.

**Do not use this instrument if it has failed.**

The use of this instrument in a state of failure could result in fire or electrical shock. In the case of failure, contact our office or our sales distributors for repair.

**Be sure to read this page to assure safety.**

## **Cautions** (cont'd)

**Always use this instrument only within the rated operating range.**

The use of this instruction out of the rated operating range could result in power failure. The temperature and humidity ranges that allow the use of this instrument are as follows:

|                   |                                 |
|-------------------|---------------------------------|
| Temperature       | : 0 °C to +40°C                 |
| Relative humidity | : 90% or less (at 0°C to +40°C) |
| Operation         | : Indoor use only               |

**Do not apply voltage to an input terminal (CH1, CH2, CH3, CH4 and Z AXIS IN) exceeding the posted rating.**

Applying a voltage exceeding the posted rating could result in power failure. The maximum voltage than can be applied is as follows:

- CH1, CH2, CH3, CH4 input

Direct

At 1 M $\Omega$  :  $\pm 400$  V (DC+ACpeak)

At 50  $\Omega$  (CH1, CH2) : 5 V rms

With PP005 (10:1) or equivalent :  $\pm 500$  V (DC+ACpeak)

- Z AXIS IN :  $\pm 40$  V (DC+ACpeak)

[Note] The maximum input voltage derates depending on frequency and high voltage pulse of an input signal.

**Do not raise trace or character intensity beyond what is necessary.**

The use of an intensity beyond what is necessary could result in eye fatigue or burn in of the CRT.

**To assure safety, be sure to disconnect the power cord if the instrument is not to be used for a long period.**

**When transporting this instrument, be sure to use the original packing material that came with the instrument or other packing material that is equal or superior.**

Large vibrations and/or shocks applied to the instrument during transportation could result in power failure and fire. If there is no appropriate packing material and/or cushion material, consult our office or our sales distributors.

When using a carrier, label "precision machine" on each face of the packing box.

Cleaning should be limited to the exterior of the instrument only, using a damp, soft cloth. Do not use chemicals or abrasive elements. Under no circumstances should moisture be allowed to penetrate the oscilloscope. To avoid electric shocks, disconnect the instrument from the power supply before cleaning.

# Contents

|  |    |
|--|----|
| Introduction .....                                   | I  |
| Cautions for safe use .....                          | I  |
| Warnings .....                                       | II |
| Cautions .....                                       | V  |
| Unpacking .....                                      | IX |
| Components .....                                     | IX |
| Explanations of terms .....                          | X  |
| <br>   |    |
| Section 1. Operating Points .....                    | 1  |
| 1.1 Front Panel .....                                | 1  |
| 1.1.1 The power source and screen .....              | 2  |
| 1.1.2 Vertical axis .....                            | 3  |
| 1.1.3 Horizontal Axis, etc. ....                     | 4  |
| 1.1.4 Trigger Section and Display Mode Section ..... | 5  |
| 1.1.5 Functions, Cursors, Sweep Modes, etc. ....     | 6  |
| 1.2 Rear Panel .....                                 | 7  |
| <br>   |    |
| Section 2. Basic Operation .....                     | 8  |
| 2.1 Displaying CAL Signal with AUTO SET .....        | 10 |
| 2.2 Probe Compensation .....                         | 12 |
| 2.3 Adjustment of the screen .....                   | 13 |
| 2.4 Vertical and Horizontal Positioning .....        | 14 |
| 2.5 Vertical Deflection System .....                 | 15 |
| 2.5.1 Deflection Factor .....                        | 15 |
| 2.5.2 Input coupling .....                           | 16 |
| 2.5.3 Input resistance .....                         | 17 |
| 2.5.4 Display Channels .....                         | 18 |
| 2.5.5 ALT and CHOP .....                             | 18 |
| 2.5.6 Sum and Difference .....                       | 19 |
| 2.5.7 Bandwidth limiter .....                        | 19 |
| 2.5.8 Offset .....                                   | 20 |
| 2.5.8.1 CH1/CH2 offset .....                         | 20 |
| 2.5.8.2 PROBE P1/P2 offset .....                     | 21 |
| 2.6 A Sweep and B Sweep .....                        | 22 |
| 2.7 Sweep Rate and Magnification .....               | 23 |
| 2.7.1 Sweep Rate .....                               | 23 |
| 2.7.2 Magnification .....                            | 23 |
| 2.7.3 CH2 Delay Adjust .....                         | 24 |
| 2.8 Sweep Mode .....                                 | 25 |



|                               |   |    |
|-------------------------------|---|----|
| 2.8.1                         | Repetitive sweep .....  | 25 |
| 2.8.2                         | Single Sweep .....  | 25 |
| 2.9                           | Triggering .....  | 26 |
| 2.9.1                         | Trigger Source .....  | 26 |
| 2.9.2                         | Trigger Coupling .....  | 26 |
| 2.9.3                         | Trigger Slope .....   | 27 |
| 2.9.4                         | Trigger Level .....   | 27 |
| 2.9.5                         | TV Signal .....   | 28 |
| 2.9.5.1                       | TV signal modes and the number of lines .....                                   | 28 |
| 2.9.5.2                       | TV Clamp .....  | 29 |
| 2.9.6                         | Event Trigger .....   | 30 |
| 2.10                          | Horizontal Display .....  | 32 |
| 2.11                          | Trace Separation .....  | 33 |
| 2.12                          | Delayed Sweep .....   | 34 |
| 2.12.1                        | Continuous Delay .....  | 34 |
| 2.12.2                        | Triggered Delay .....   | 35 |
| 2.13                          | Holdoff .....   | 36 |
| Section 3.                    | Cursor Measurement and Counter .....  | 38 |
| 3.1                           | Time Difference ( $\Delta t$ ) and Frequency ( $1/\Delta t$ ) Measurement ..... | 38 |
| 3.2                           | Voltage Difference ( $\Delta V$ ) Measurement .....                             | 40 |
| 3.3                           | Counter .....   | 41 |
| Section 4.                    | Save/Recall .....   | 42 |
| 4.1                           | Save .....  | 42 |
| 4.2                           | Recall .....  | 44 |
| Section 5.                    | Daily Inspections .....   | 45 |
| Section 6.                    | Specifications .....  | 48 |
| Probe SS-101R (Specification) | .....   | 53 |

## Unpacking

The figure below depicts the unpacking procedure.

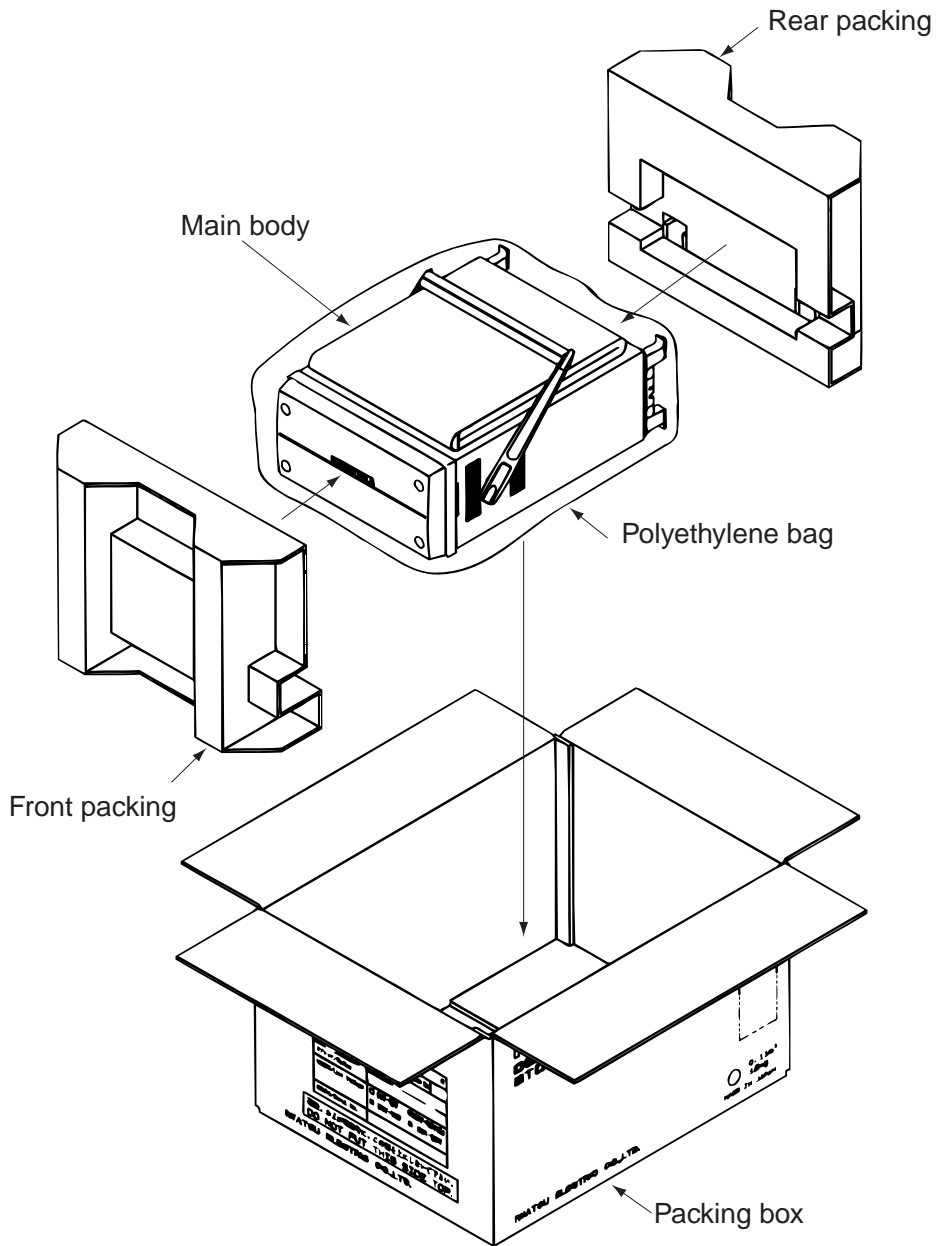

## Components

Check that the following items are included:

- SS-7840 ..... 1
  - Accessories
    - Power cord (three-core type) ..... 1
    - Panel cover ..... 1
    - Fuse ..... 2
    - Operation manual ..... 1
    - Accessory bag ..... 1
    - Probe SS-101R ..... 2
- (Probe accessories are included)

## Explanations of terms

|                       |  |
|-----------------------|--|
| A sweep               | : Ordinary sweep system  |
| ADD                   | : Display of the sum of CH1 waveform and CH2 waveform (abbreviation from ADDITION)   |
| AC (input coupling)   | : An input coupling system where a filter is applied to the input circuit so that the DC (direct current) component is removed from the signal                                       |
| AC (trigger coupling) | : A trigger coupling system where a filter is applied to the trigger circuit so that the DC (direct current) component is removed from the signal                                    |
| ALT (vertical)        | : Mutually switched sweep of multiple waveforms on the same screen (abbreviation from ALTERNATE)   |
| ALT (horizontal)      | : Display of A sweep and B sweep on the same screen (abbreviation from ALTERNATE)  |
| ATTACH                | : Selection of the object channel for cursor measurement or offset   |
| B sweep               | : The sweep system used for delayed sweep  |
| BEAM FIND             | : Display of the waveform that was outside the screen in the screen (abbreviation from BEAM FINDER)  |
| B ENDS A              | : To increase the intensity by shortening A sweep with delayed sweep (refer to “2.12 Delayed Sweep”).  |
| BOTH                  | : Both of the odd- and even-numbered fields of the vertical synchronizing TV signals   |
| BURST                 | : One of event triggers, where a triggering is set when the time interval of the trigger signal exceeds the specified length (refer to “2.9.6 Event Trigger”).                       |
| BWL                   | : Limitation on the vertical bandwidth (abbreviation from BANDWIDTH LIMITATION)  |
| CAL                   | : A signal for calibration, which is used for calibration of deflection factor and the check of the operation of this instrument (abbreviation from CALIBRATION)                     |
| CH                    | : Channel (abbreviation from CHANNEL)  |
| CHOP                  | : Mutually switched display of multiple waveforms on the same screen   |
| CLAMP                 | : Display of the back porch of TV signals as converted into that on the reference level (ground level)   |
| COUPLE                | : Synchronous coupling system (abbreviation from COUPLING)   |
| COUNT                 | : One of event triggers, where a triggering is set when the specified numbers of B trigger signals are counted after the A trigger signal occurred (refer to “2.9.6 Event Trigger”). |
| CRT                   | : Cathode ray tube   |
| DC (input coupling)   | : The input coupling system that allows the passage of both DC and AC signals  |
| DC (trigger coupling) | : The trigger coupling system that allows the passage of both DC and AC signals  |
| DIV                   | : Division   |
| EVEN                  | : Even-numbered fields of vertical synchronizing TV signals  |

|                              |  |
|------------------------------|--|
| EVENT                        | : Event trigger (this unit has the COUNT and BURST types)  |
| FET                          | : Field effect transistor  |
| FET probe                    | : An active probe with an FET at the tip   |
| GND                          | : Grounding  |
| H cursor                     | : The cursor used for measuring time by moving in the horizontal direction                         |
| HD TV                        | : TV system of high-definition type (abbreviation from HIGH DEFINITION TELEVISION)                 |
| HF REJ                       | : Low-pass filter for removing high-frequency bands (abbreviation from HIGH FREQUENCY REJECTION)   |
| HOLDOFF                      | : Holdoff time (facilitate the observation of complex pulse signals by adjusting the holdoff time) |
| HORIZ                        | : Horizontal   |
| INDEP                        | : Move the cursor independently (abbreviation from INDEPENDENCE)                                   |
| INTEN                        | : Intensity, brightness of the screen (abbreviation from INTENSITY)                                |
| INV                          | : Inverting the vertical display on the screen (abbreviation from INVERSION)                       |
| LF REJ                       | : High-pass filter for removing low-frequency bands (abbreviation from LOW FREQUENCY REJECTION)    |
| LINE (trigger signal source) | : One of trigger signal sources. A power line is used as a trigger signal source.                  |
| LINE (TV)                    | : Line No. of horizontal synchronization signal  |
| MAG                          | : Magnifying waveform in the horizontal direction (abbreviation from MAGNIFY)                      |
| MAX                          | : Maximum value  |
| NTSC                         | : A color television system (abbreviation from NATIONAL TELEVISION SYSTEM COMMITTEE)               |
| ODD                          | : Odd-numbered fields of vertical synchronizing TV signals   |
| PAL                          | : A color television system (abbreviation from PHASE ALTERNATION BY LINE)                          |
| READOUT                      | : Intensity of characters displayed (abbreviation from READOUT INTEN)                              |
| RH                           | : Relative humidity  |
| RECALL                       | : Recalling the setting conditions saved in the built-in memory                                    |
| RST                          | : Reset  |
| SAVE                         | : Saving the panel key setting conditions in the built-in memory                                   |
| SCALE                        | : Illumination of the scale on the CRT (abbreviation from SCALE ILLUMINATION)                      |
| SECAM                        | : A color television system (abbreviation from SEQUENTIEAL COULEUR A MEMOIRE in French)            |
| SEP                          | : Separating A sweep and B sweep from each other (abbreviation from SEPARATION)                    |

|                |   |
|----------------|---|
| SGL            | : Sweeping only once (abbreviation from SINGLE)   |
| SLOPE          | : Trigger slope   |
| SOURCE         | : Trigger signal source   |
| STBY           | : Stand-by  |
| TCK            | : Moving cursors while maintaining the intervals between them (abbreviation from TRACK)   |
| TRACE ROTATION | : Adjusting the inclination of a trace so that it matches with the horizontal division  |
| TRIG           | : Trigger   |
| Tr (rise time) | : A pulse response characteristic - the time during which the momentary value of the rise portion is 10 to 90% of the basic amplitude                           |
| TV-H           | : Horizontal synchronizing TV signals   |
| TV-V           | : Vertical synchronizing TV signals   |
| V cursor       | : The cursor used for measuring voltage by moving in the vertical direction   |
| VSWR           | : Voltage standing wave ratio   |
| X-Y            | : A system where different signals are input and displayed on the X and Y axes so as to observe the frequency ratio and/or phase difference between two signals |

# Section 1. Operating Points

## 1.1 Front panel

Figure 1.1.1 shows the overall view. Refer to page 2 and the pages that follow for details.

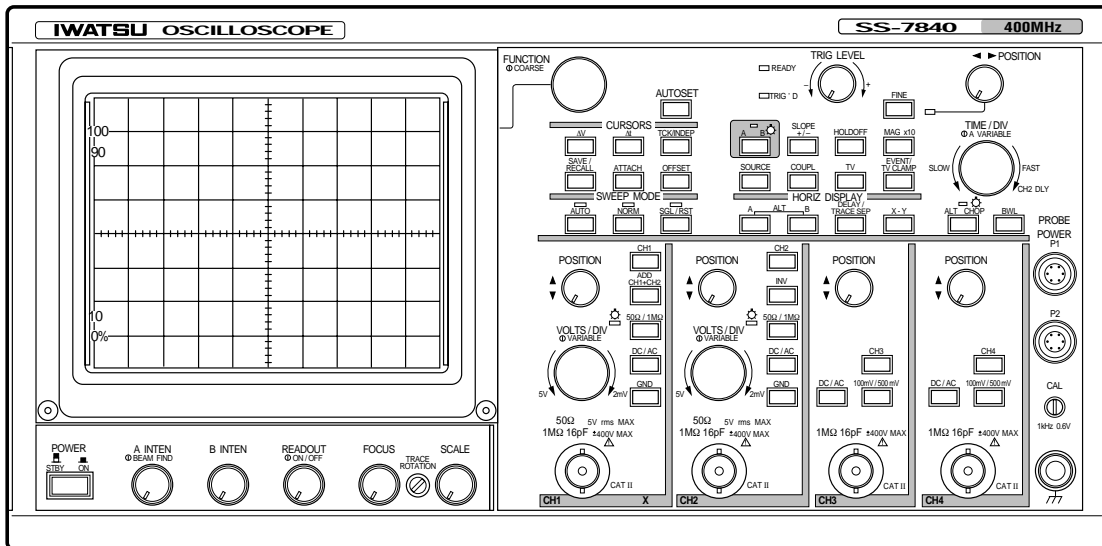

Figure 1.1.1 Front Panel I (Overall view)

### Symbols on the panel

Warning symbol

This symbol calls the user's attention to the descriptions in the instruction manual. This symbol is marked near the CH1 to CH4 INPUT terminals.

### Symbols in the instruction manual.

Expression of keys and knobs

: Indicates a key.

: Indicates a knob. There are two types of knobs as follows:

- To be operated by turning.
- To be operated by turning and pressing.

When two switches are pressed simultaneously, they are expressed with a symbol of "+" inserted between them.

[Example] : +

### 1.1.1 The power source and screen

See Figure 1.1.2.

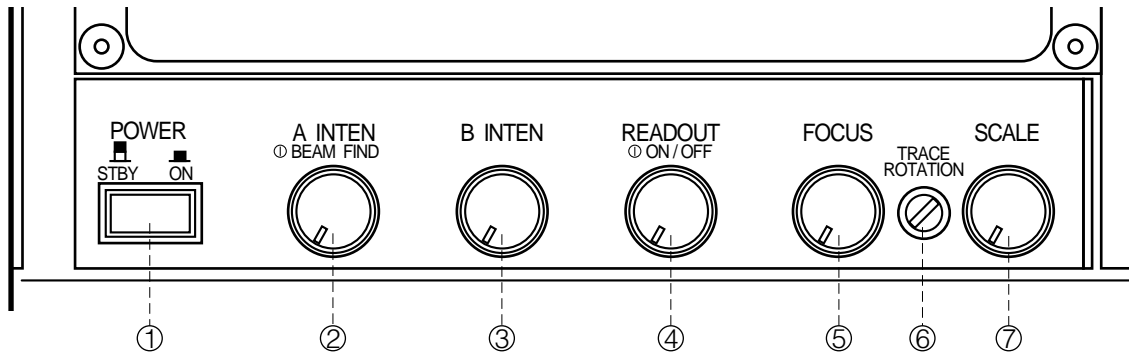

Figure 1.1.2 Front Panel I

#### **POWER** key

Sets the AC power source to ON or STBY. Refer to the column shown below.

#### **[A INTEN (BEAM FIND) knob**

- A INTEN volume knob: Adjusts the trace intensity of A sweep (refer to “2.3 Adjustment of the Screen”).
- BEAM FIND switch: Displays a compressed waveform on the screen (refer to “2.3 Adjustment of the Screen”).

#### **[B INTEN] knob:**

Adjusts the trace intensity of B sweep (refer to “2.3 Adjustment of the Screen”).

#### **[READOUT (ON/OFF)] knob**

- READOUT volume knob: Adjusts the intensity of characters (refer to “2.3 Adjustment of the Screen”).
- ON/OFF switch: Selects ON (display) or OFF (non-display) of characters (refer to “2.3 Adjustment of the Screen”).

#### **[FOCUS] knob**

Adjusts the focus (refer to “2.3 Adjustment of the Screen”).

#### **TRACE ROTATION**

Adjusts the intensity of the trace using the driver (refer to “2.3 Adjustment of the Screen”).

#### **[SCALE] knob**

Adjusts the intensity of the scale (refer to “2.3 Adjustment of the Screen”).

#### **ON and STBY of the POWER switch.**



: Indicates a state wherein this instrument is ready for ON operation with power supplied to every circuit.

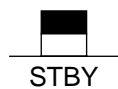

: Indicates a standby state of this instrument wherein the STBY main power supply is off. When AC power is connected to AC LINE INPUT, power is supplied to the only microprocessor in this instrument. When AC power is not connected to AC LINE INPUT, panel setup conditions are backed up by the built-in battery.

## 1.1.2 Vertical axis

See Figure 1.1.3.

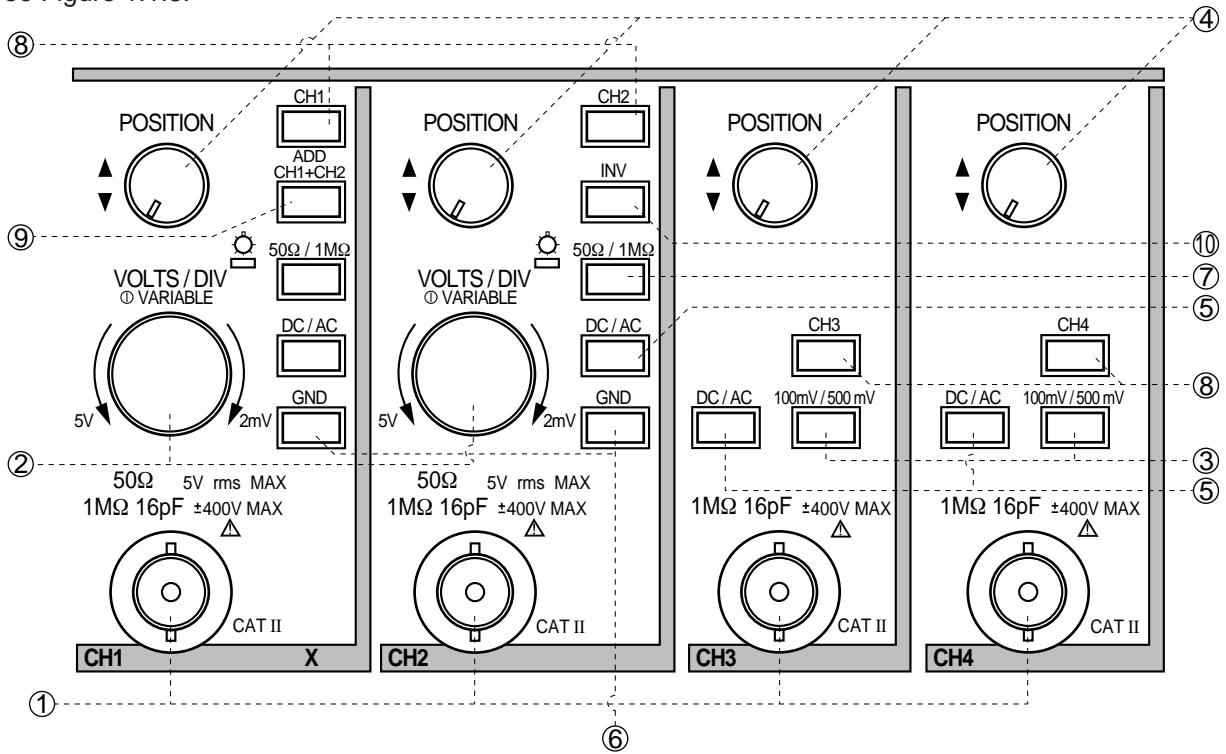

Figure 1.1.3 Front Panel II

### INPUT connectors (CH1 to CH4):

Connections for input signals.

**[Note]** Strictly observe the maximum limit on the input voltage as displayed on the panel.

### **[VOLTS/DIV (VARIABLE)] (CH1, CH2) knob:**

VOLT/DIV switch: Selects the deflection factor in 1-2-5 seteps (refer to “2.5.1 Deflection Factor”).

VARIABLE switch: Finely adjusts the deflection factor (refer to “2.5.1 Deflection Factor”).

### **[100mV/500mV] (CH3, CH4) key:**

Select the deflection factor (refer to “2.5.1 Deflection Factor”).

### **[▲POSITION▼] (CH1 to CH4) knob:**

Move the position in the vertical direction (refer to “2.4 Vertical and Horizontal Positioning”).

### **[DC/AC] (CH1 to CH4) key:**

Select the input coupling (refer to “2.5.2 Input Coupling”).

### **[GND] (CH1, CH2) key:**

Connect the input coupling to the GND (refer to “2.5.2 Input Coupling”).

### **[50Ω/1MΩ] (CH1, CH2) key:**

Select the input resistance. The indicator lights when 50Ω is selected (refer to “2.5.3 Input Resistance”).

### **[CH1], [CH2], [CH3], [CH4] key:**

Select the channel to be displayed on the screen (refer to “2.5.4 Display Channels”).

### **[ADD CH1 + CH2] key:**

Displays the sum of CH1 and CH2 (refer to “2.5.6 Sum and Difference”).

### **[INV] key:**

Displays the input of CH2 in reversal (refer to “2.5.6 Sum and Difference”).



### 1.1.3 Horizontal Axis, etc.

See Figure 1.1.4.

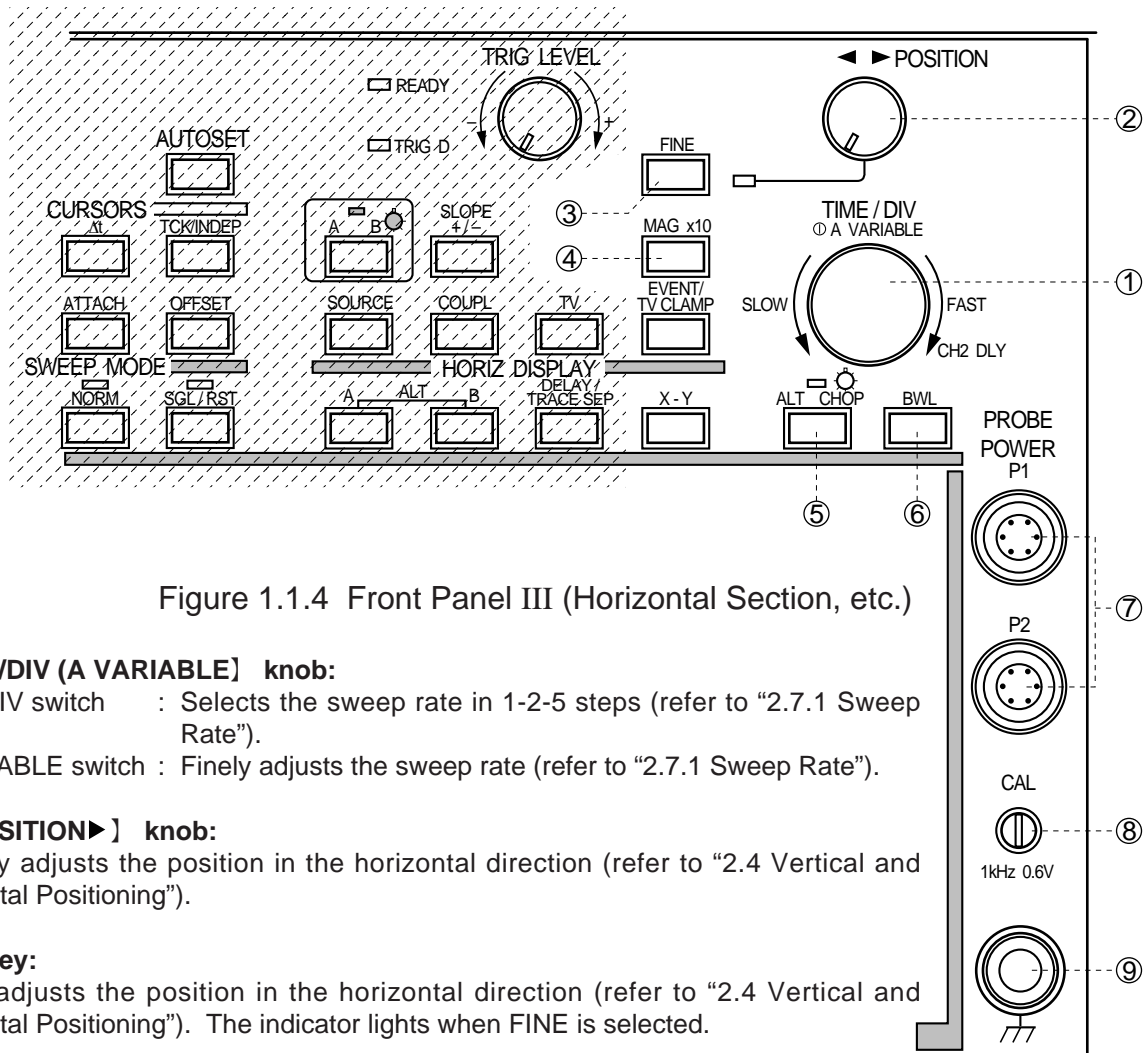

Figure 1.1.4 Front Panel III (Horizontal Section, etc.)

**[TIME/DIV (A VARIABLE)] knob:**

TIME/DIV switch : Selects the sweep rate in 1-2-5 steps (refer to “2.7.1 Sweep Rate”).

A VARIABLE switch : Finely adjusts the sweep rate (refer to “2.7.1 Sweep Rate”).

**[◀POSITION▶] knob:**

Roughly adjusts the position in the horizontal direction (refer to “2.4 Vertical and Horizontal Positioning”).

**[FINE] key:**

Finely adjusts the position in the horizontal direction (refer to “2.4 Vertical and Horizontal Positioning”). The indicator lights when FINE is selected.

**[MAG X 10] key:**

Magnifies the waveform (x 10) in the horizontal direction (refer to “2.7.2 Magnification”).

**[ALT CHOP] key:**

Selects ALT or CHOP (refer to “2.5.5 ALT and CHOP”). The indicator lights when CHOP is selected.

**[BWL] key:**

Selects the frequency band (refer to “2.5.7 Bandwidth limiter”).

**PROBE POWER P1, P2 terminals:**

Supply power to FET probes.

**CAL terminal:**

Outputs calibration voltage signals. Used for operation check of this unit and the adjustment of the probe waveform (refer to “2.1 Display of CAL Waveform With AUTO SET”).

**⏏ (grounding) connector:**

This is the grounding for measurement.

### 1.1.4 Trigger Section and Display Mode Section

See Figure 1.1.5.

**[TRIG LEVEL] knob:**

Selects the trigger level (refer to “2.9.4 Trigger Level”).

**READY indicator:**

Lights while waiting for signals.

**TRIG'D indicator:**

Lights when a trigger pulse has been generated.

**[A B] key:**

Selects A (sweep and trigger) or B (sweep and trigger) (refer to “2.12 Delayed Sweep”).

The indicator lights when B is selected.

**[SLOPE] key:**

Select the trigger slope (+, -) (refer to “2.9.3 Trigger Slope”).

**[HOLDOFF] key:**

Selects the holdoff time (refer to “2.13 Holdoff”).

**[SOURCE] key:**

Select the trigger signal source (CH1, CH2, CH3, or LINE) (refer to “2.9.1 Trigger Source”).

**[COUPL] key:**

Select the trigger coupling mode (AC, DC, HF REJ, or LF REJ) (refer to “2.9.2 Trigger Coupling”).

**[TV] key:**

Selects triggering with TV (BOTH, ODD, EVEN, or TV-H) (refer to “2.9.5.1 TV Signal”).

**[EVENT/TV CLAMP] key:**

Selects event (refer to “2.9.6 Event Trigger”) or TV clamp (refer to “2.9.5.2 TV Clamp”).

**– HORIZ DISPLAY (display mode) –**

**[A] or [B] key:**

Displays A sweep or B sweep (refer to “2.10 Horizontal Display”). Simultaneous depression of [A] and [B] selects ALT sweep.

**[X-Y] key:**

Effects X-Y display (refer to “2.10 Horizontal Display”).

**[DELAY/TRACE SEP] key:**

Selects DELAY (refer to “2.12 Delayed Sweep”) or TRACE SEP (refer to “2.11 Trace Separation”).

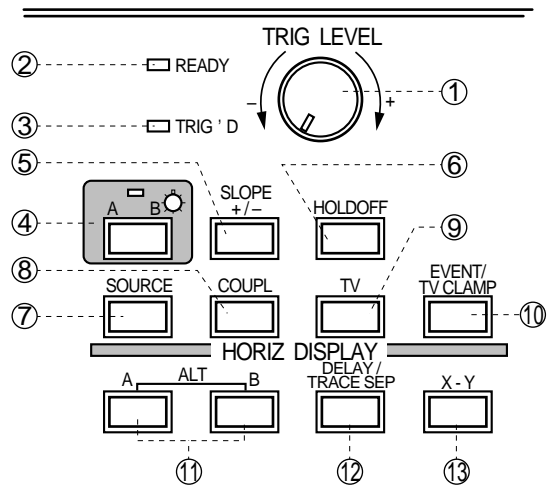

Figure 1.1.5 Front Panel IV (Trigger Section and Display Mode Section)

## 1.1.5 Functions, Cursors, Sweep Modes, etc.

See Figure 1.1.6.

### **[FUNCTION] pulse switch:**

The delay time, cursor position, etc. can be set by turning or pressing this knob. Fine adjustment can be effected by turning this knob. Coarse adjustment in the direction this knob has been turned so far can be effected each time this knob is pressed or continuously held down.

### **AUTO SET key:**

Measuring conditions are set automatically. (refer to “2.1 CAL wave display with AUTO SET”).

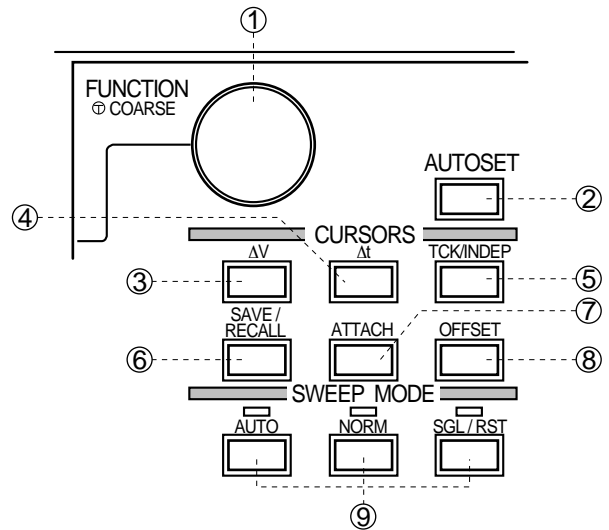

Figure 1.1.6 Front Panel IV (Functions, Cursors, Sweep Modes, etc.)

### – CURSORS –

#### **$\Delta V$ key:**

Measures the voltage using a cursor (refer to “Section 3 Cursor Measurement and Counter”).

#### **$\Delta t$ key:**

Measures the time using a cursor (refer to “Section 3 Cursor Measurement and Counter”).

#### **TCK/INDEP key:**

Selects the type of cursor to be moved (C1, C2, or tracking) (refer to “Section 3 Cursor Measurement and Counter”).

#### **SAVE/RECALL key:**

Selects Save or Recall (refer to “Section 4 Save/Recall”).

#### **ATTACH key:**

- Selects the measurement object channel for the measurement with a cursor (refer to “3.2 Voltage Difference”).
- Selects the channel (CH1/CH2) or terminal (P1/P2) for the offset (refer to “2.5.8 Offset”).

#### **OFFSET key:**

Set the offset of CH1/CH2 or FET probe (refer to “2.5.8 Offset”).

### – SWEEP MODE –

#### **AUTO, NORM, or SGL/RST key:**

Selects repetitive sweep (AUTO, NORM) or single sweep (SGL) (refer to “2.8 Sweep Mode”).

- The indicator corresponding to the sweep mode that is selected lights.

## 1.2 Rear panel

See Figure 1.2.1.

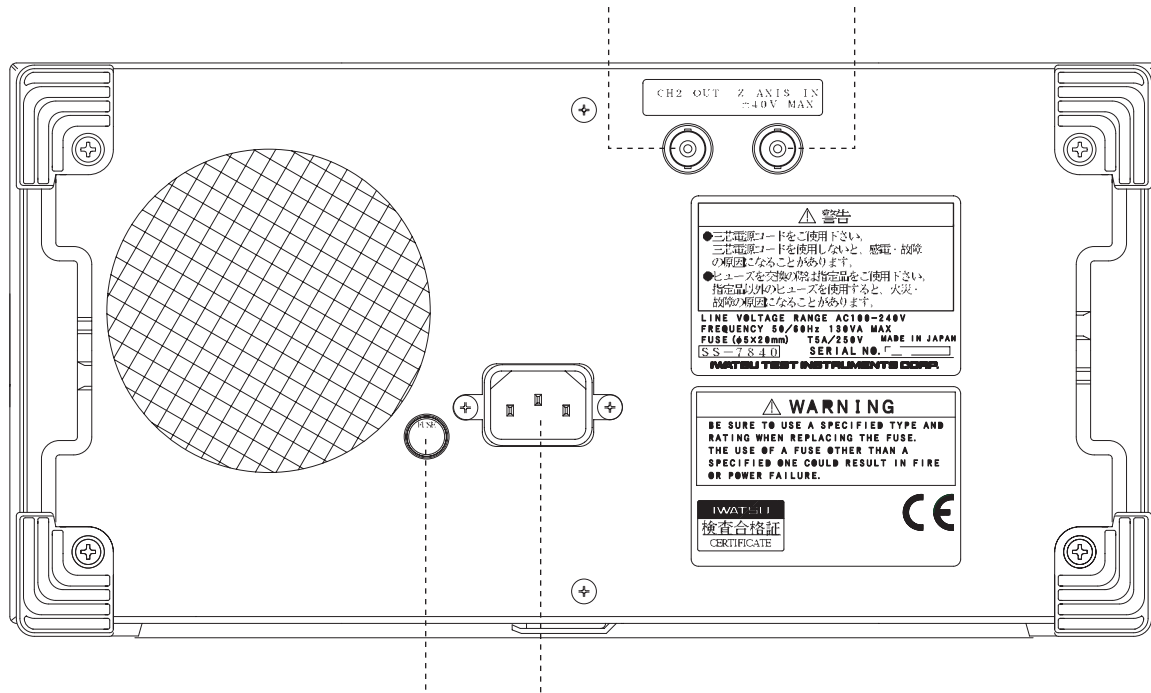

Figure 1.2.1 Rear Panel

### AC LINE INPUT

Connect the power cord to this receptacle.

### FUSE

5 x 20 mm, T5 A/250 V fuse.

### CH2 OUTPUT terminal

Outputs the signal input to CH2 INPUT.

Amplitude of output signal = Amplitude on the screen x output voltage

### Z AXIS IN terminal

Inputs the intensity modulation signal.

## Section 2. Basic Operation

### Cautions

**Be sure to connect or remove the power cord after setting the power switch to STBY.**

**Use this instrument with the rated AC power supply.**

Voltage range : 100 to 240 VAC

Frequency : 50/60 Hz

Power consumption : 130 VA

**Be sure to use a 3-core power cord appropriate to the supply voltage.**

**Do not place any object in the vicinity of the air hole or fan of this instrument.**

**Use this instrument within the rated operating range. (Indoor use only)**

Temperature: 0 to +40 °C, humidity: 90%RH (at 40 °C)

**Power is applied to this instrument if the power switch is set to STBY. Disconnect the power cord from the receptacle if the instrument is not to be used for a long time.**

**Do not apply voltage to the input terminal exceeding the posted rating.**

- CH1, CH2, CH3, CH4 input at 1 M $\Omega$

Direct :  $\pm 400$  V (DC+ACpeak)

With the SS-101R or equivalent :  $\pm 500$  V (DC+ACpeak)

- CH1, CH2 at 50  $\Omega$  : 5 Vrms

[Note] The maximum input voltage derates depending on frequency and high voltage pulse of an input signal.

**Do not raise trace or character intensity beyond what is necessary.**

This instruction is for two purposes: 1) to protect the user's eyes from eye strain and fatigue, and 2) to protect the CRT from burn-in.

### General

Perform basic operation using CAL output and a signal generator so as to become familiar with this instrument. The Iwatsu FG-350 is used for the signal generator.

#### ◇ Grounding

Connect the measurement grounding terminal (Right side of CH4 INPUT) to GND of the circuit being measured. Grounding is particularly important to measure high-frequency signals accurately. Connect the grounding lead of the probe as closely as possible to the grounding terminal near the signals.

#### ◇ Settings when power is set STBY or OFF \*1

When power is set STBY or OFF, the panel setup immediately before such setting is stored. When power is turned on again, operation restarts with the panel setup immediately before the setting to STBY or OFF. When power is set to OFF, the panel setup is backed up by the built-in batteries.

\*1 The state where the power cord is disconnected.

#### ◇ Built-in battery

- When the built-in battery has been consumed, the setup conditions are initialized when power has been turned on.
- The built-in battery is not sold in the market. When replacing it, please contact your nearest marketing office.

◇ How to read the screen

- Main contents of display

|   |                  |                 |                  |                 |                     |               |          |     |       |          |     |       |          |                   |
|---|------------------|-----------------|------------------|-----------------|---------------------|---------------|----------|-----|-------|----------|-----|-------|----------|-------------------|
| A SWEEP RATE                            | A TRIGGER SOURCE | A TRIGGER SLOPE | A TRIGGER COUPLE | A TRIGGER LEVEL | Sweep magnification | HOLDOFF TIME  |          |     |       |          |     |       |          |                   |
| B SWEEP RATE                            | B TRIGGER SOURCE | B TRIGGER SLOPE | B TRIGGER COUPLE | B TRIGGER LEVEL |                     | DELAY TIME    |          |     |       |          |     |       |          |                   |
|   |                  |                 |                  |                 |                     | FUNCTION MODE |          |     |       |          |     |       |          |                   |
|   |                  |                 |                  |                 |                     |               |          |     |       |          |     |       |          |                   |
| Measurement of $\Delta V$ or $\Delta t$ |                  |                 |                  |                 | Frequency measured  |               |          |     |       |          |     |       |          |                   |
| CH1                                     | Range            | Coupling        | ADD              | CH2             | INV                 | Range         | Coupling | CH3 | Range | Coupling | CH4 | Range | Coupling | Bandwidth limiter |

- An example of the display

|    |                         |                          |                |          |       |                   |
|----|-------------------------|--------------------------|----------------|----------|-------|-------------------|
| A  | 10 $\mu s$              | CH1                      | + DC           | - 1.00mV | MAG   | HO : 100%         |
| B  | 1 $\mu s$               | CH2                      | - DC           | 3.00mV   |       | DLY 99.00 $\mu s$ |
|    |                         |                          |                |          |       | f:B-DELAY         |
|    |                         |                          |                |          |       |                   |
| A  | $\Delta t = 5.00 \mu s$ | $1/\Delta t = 200.0 kHz$ | f = 200.00 kHz |          |       |                   |
| 1: | 100mV                   | + 2: ↓                   | 200mV          | 3:       | 500mV | 4: 500mV BW20     |

## 2.1 Displaying CAL Signal with AUTO SET

Display the CAL waveform (1 kHz, 0.6 V square wave) on CH1 using the AUTO SET function of this instrument.

### Operating method

#### Procedures

##### Turning power on

Set power to STBY BY PRESSING **POWER** .

Connect the power cord to the AC LINE INPUT on the rear panel and to the AC power source.

Press **POWER** to turn on the power.

- Traces, characters, or both are displayed on the screen.

Connect the CH1 input connector and CAL connector with the attached probe.

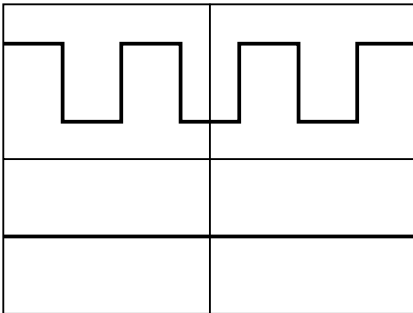
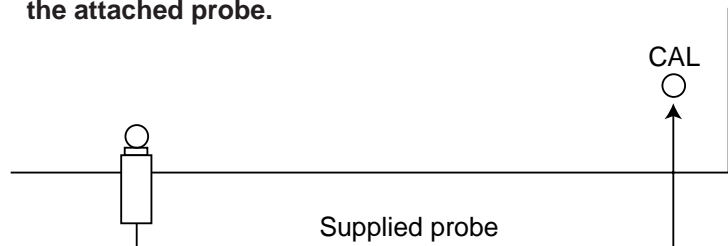

← Press **AUTO SET** .

- The CAL waveform is displayed on the screen.
- If the CAL waveform does not appear, adjust the intensity (refer to “2.3 Adjustment of the screen”).

#### AUTO SET function

- Press **AUTO SET** in a state such that “the size of signal is unknown, frequency is unknown, or operation mode is unknown”. This instrument automatically selects the measurement conditions suitable for observation (See Table 2.1.1 Measurement conditions of AUTO), based on the amplitude and/or frequency of the input signal and the waveform is displayed on the screen.
- Sometimes suitable measurement conditions cannot be found depending on the frequency, amplitude, and/or duty ratio of the input signal.

Table 2.1.1 Measurement conditions of AUTO SET

| Vertical deflection system  | Triggering   |
|---|--|
| Deflection factor<br>VOLTS/DIV : When the frequency is between 50 Hz and 100 MHz, 2 mV to 5 V/div with an amplitude of 1.5 to 8 div<br>VARIABLE : OFF (CAL)   | A/B : A<br>SOURCE : Detected in the order of CH1 and CH2<br>COUPL : DC<br>TV : When the former setting is TV MODE, whether it was TV-H, NTSC, PAL, or HDTV is automatically judged. When there is no corresponding TV-MODE, TV is released.<br>SLOPE : + (“-” in the case of TV mode)<br>LEVEL : About 0 div |
| Display channel<br>CH1 : Former setting * 1<br>CH2 : Former setting * 1<br>CH3 : OFF (non display)<br>CH4 : OFF (non display)<br>* 1 CH1 alone is set to ON if both CH1 and CH2 have been set to OFF. |  |
| POSITION<br>In case of 1-channel display : In the middle<br>In case of 2-channel display<br>CH1 : About + 2 div<br>CH2 : About - 2 div  | <b>Horizontal deflection system</b><br>HORIZ DISPLAY : A<br>TIME/DIV : 50 ms to 10 ns/div, approx. 2 to 5 cycles<br>VARIABLE : OFF   |
| AC/DC : Former setting * 2<br>50Ω/1MΩ : Former setting * 3<br>GND : OFF (GND released)<br>ALT/CHOP : CHOP<br>CH2 INV : OFF<br>BWL : OFF (no Bandwidth limiter)<br>ADD : OFF                           | SWEEP MODE : AUTO<br>POSITION : Sweep starts from a position near the left end of the screen.<br>READ OUT : ON   |

\* 1 When both CH1 and CH2 are OFF, CH1 is set to ON.

\* 2 When this is set to DC, AC coupling occurs when the waveform goes outside the moving range of the position.

\* 3 When this is set to 50Ω, it becomes 1 MΩ when the waveform goes outside the moving range of the position.  
 When 1 MΩ is set, the setting of input coupling (AC/DC) becomes AC.

[Note] When an adequate amplitude cannot be detected, the following will be set on that channel:

VOLTS/DIV : 10mV/DIV  
 50Ω/1MΩ : 1MΩ  
 AC/DC : AC



## 2.2 Probe Compensation

Adjust the waveform on the attached probe. Be sure to confirm that the waveform of the probe is compensated correctly before using the probe.

### Operating method

### Procedures

#### Set this unit as follows:

CH1 VOLTS/DIV : 10 mV  
 GND : OFF (GND released)  
 AC/DC : DC  
 SOURCE : CH1  
 SEC : 200  $\mu$ s

Take triggering by turning [TRIG LEVEL] .

Adjust the waveform by turning the variable capacitor of the probe with a screwdriver.

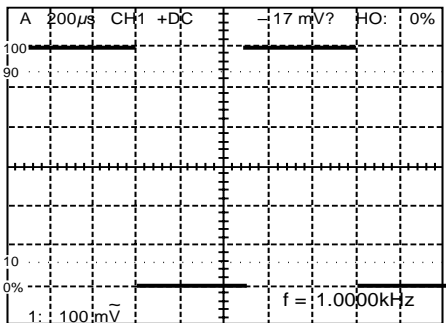

← • Correctly compensated waveform

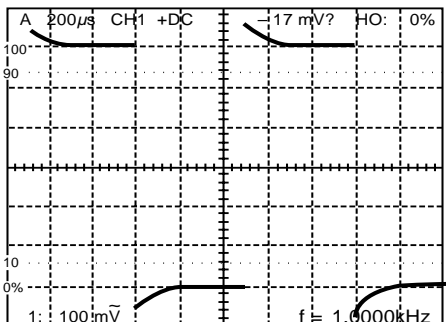

← • Over compensated waveform

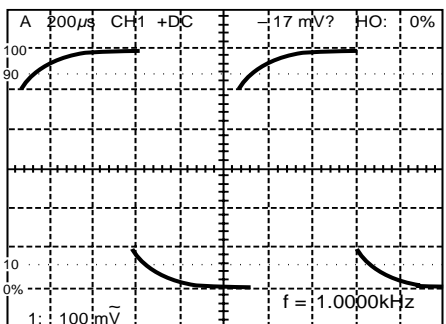

← • Under compensated waveform

#### ◇ Probe sense (display of deflection factor)

When the probe has a probe sense function, the voltage as compensated by the attenuation ratio of the probe is displayed.

#### ◇ Releasing the loading effect by a probe

If a cable, etc. is directly connected to the circuit under measurement, observation may be disturbed by the load applied by the input impedance of the measuring equipment. The input RC of this unit is "1 M $\Omega$ , 16 pF." If a 10 : 1 probe is used, the input RC becomes "10 M $\Omega$ , 13 pF" and thus the loading effect is largely released enabling the measurement with a high accuracy.

## 2.3 Adjustment of the screen

Adjust the brightness (**A INTEN**), displayed characters (**READOUT**), focus (**FOCUS**), intensity of scales (**SCALE**), and rotation of traces (**TRACE ROTATION**).

### Operating method

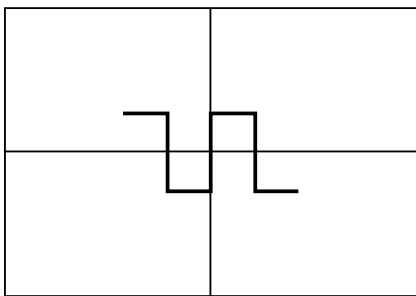
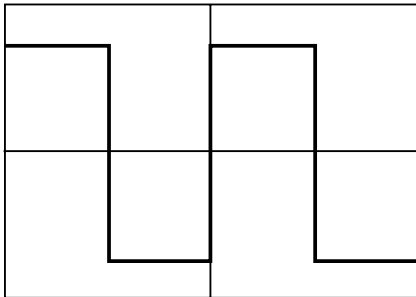

A 5 ms CH 1 + AC

1 : 5 mV

### Procedures

- ← Adjust the A sweep brightness of traces by turning **[A INTEN]** .

### Press **[A INTEN (BEAM FIND)]** .

- ← • Compresses the vertical and horizontal deflection to within the graticule area.
- Return to the original state after confirmation.

- ← **Adjust the brightness of displayed characters by turning [READ OUT] .**
- ON/OFF is switched each time **[READ OUT]** is pressed.

### Adjust the focus of traces and displayed characters by turning **[FOCUS]** .

### Adjust graticule illumination by turning **[SCALE]** .

- Perform step and if trace is inclining due to earth magnetism, etc.

- ← Set the input coupling of CH1 to GND by pressing **[GND]** .

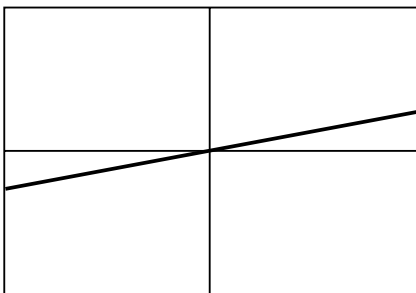

- ← **Correct the inclination of the trace by turning TRACE ROTATION on the front panel with the attached adjustment screwdriver.**

- Return the input coupling to the original setting after correcting the inclination.

### **B INTEN**

Turn **[B INTEN]** when adjusting the trace intensity of B sweep.  
Refer to "2.10 Horizontal Display" for B sweep.

## 2.4 Vertical and Horizontal Positioning

Adjust the vertical and horizontal positions. This function is used to move the waveform to a position where it can be observed easily or when performing comparative measurement of two or more waveforms by laying one waveform on another.

### Operating method

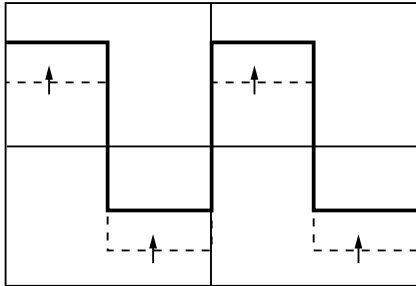

### Procedures

#### Moving vertical positions

- ← Turn [▲POSITION▼] of CH1 to the right; the waveform moves upward.
- Turn [▲POSITION▼] of CH1 to the left; the waveform moves downward.
- ◇ Perform the same operation on CH2 and CH4 as well.

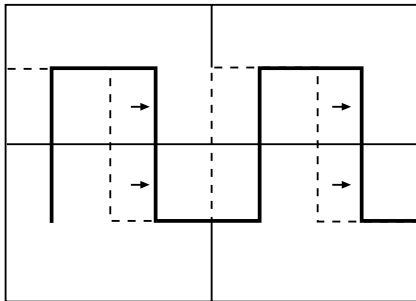

#### Moving horizontal positions

- ← Turn [◀POSITION▶] to the right; the waveform moves to the right.
- Turn [◀POSITION▶] to the left; the waveform moves to the left.
- The FINE indicator lights or goes off every time [FINE] is pressed.
  - Fine adjustment is accomplished when [◀POSITION▶] is turned while the FINE indicator is lighted. If [◀POSITION▶] is fully turned in this case, the waveform scrolls. To stop scrolling in the middle, return [◀POSITION▶] slightly.

## 2.5 Vertical Deflection System

### 2.5.1 Deflection Factor

Set the amplitude of waveform to a size suitable for viewing.

#### a. CH1 and CH2

##### Operating method

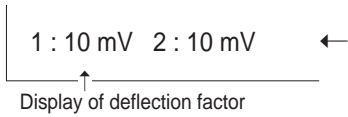

##### Procedures

##### Setting the TIME/DIV

← **Select the deflection factor by turning [VOLTS/DIV] of CH1.**

- The deflection factor can be selected with a range of 2 mV/div to 5 V/div (in 1-2-5 steps).

- The deflection factor is displayed in the lower lefthand corner of the screen.

[Note] Do automatic calibration if traces move upward or downward when the range has been switched (refer to "Section 5. Daily Inspection").

##### Setting the VARIABLE

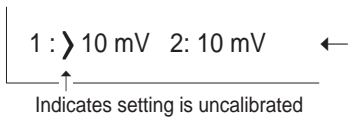

← **Press [VOLTS/DIV] of CH1; the deflection factor is displayed with ">" mark.**

- Fine adjustment can be performed using this screen.

**Turn [VOLTS/DIV] of CH1; the deflection factor varies continuously between steps .**

- While [VOLTS/DIV] is turned, the rough ratio to the original display is displayed.

- To release the variable setting mode, delete ">" by pressing [VOLTS/DIV] again.

◇ Perform the same operation on CH2 as well.

#### b. CH3 and CH4



##### Procedures

← **Select the deflection factor by pressing 100 mV/500 mV .**

- One of the three ranges of 100 mV/div, or 500 mV/div can be selected. Fine adjustment is not available.

◇ Perform the same operation on CH4 as well.

## 2.5.2 Input coupling

Select a coupling mode suitable for observation according to the type of input signal.

### Operating method

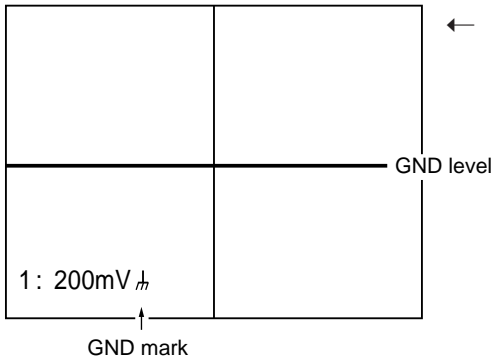

### Procedures

#### Selecting GND

Set GND to ON by pressing **GND** of CH1 (the GND mark is displayed in the lower left hand corner on the screen).

- The input section of the vertical amplifier is connected to GND and a trace (grounding potential) is displayed.
- CH3, CH4 has no GND.

[Note] Do automatic calibration if there is a difference from the actual grounding potential at the time of connection to GND (refer to "Section 5. Daily Inspection").

#### Selecting DC or AC

Set GND to OFF (GND released) by pressing **GND** of CH1.

Set DC or AC by pressing **DC/AC** of CH1.

- Cannot be set to AC when the input resistance is 50  $\Omega$ .  
When AC is selected the 50 M $\Omega$  indicator goes off and the input resistance becomes 1  $\Omega$ .
- Perform the same operation on CH2 as well.

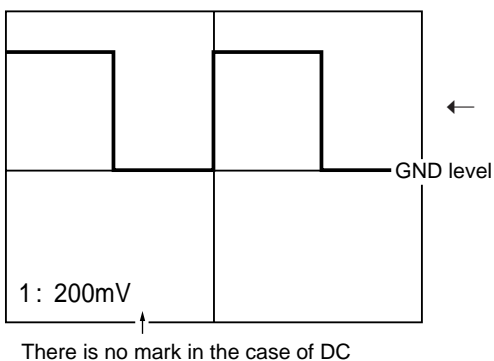

#### ◇ DC

- The DC and AC components of the input signal are displayed.
- The CAL waveform is displayed on the basis of the GND level.

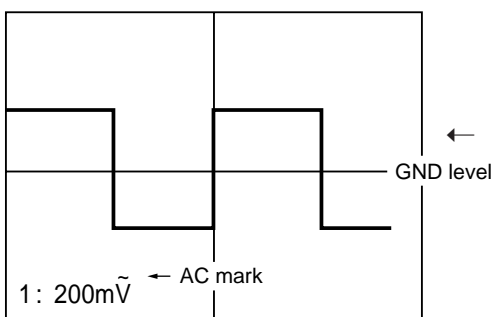

#### ◇ AC

- The AC component only of the input signal is displayed with the DC component cut.
- The CAL waveform is displayed on the middle of the average potential.
- Character "V." is displayed with the "~" mark on the top.

### 2.5.3 Input resistance

This is the function to select the input resistance.

#### Operating method

#### Procedures

**Select 50  $\Omega$  or 1 M $\Omega$  by pressing [50  $\Omega$ /1 M $\Omega$ ].**

- To select 50  $\Omega$ , keep [50  $\Omega$ /1 M $\Omega$ ] pressed for a while.
- When 50  $\Omega$  cannot be selected because the duration of pressing is too short, the message on the left is displayed.
- When 50  $\Omega$  is selected, the indicator lights.

[Note] When 50  $\Omega$  is selected, the input coupling is automatically set to DC. AC cannot be set.

◇ **Use this unit with the input resistance set to 1 M $\Omega$  in usual cases.**

◇ **How to use 50  $\Omega$**

- When measuring the signals in a high frequency band, connect this unit and the signal source with a coaxial cable having a characteristic impedance of 50 $\Omega$  and set the input resistance of this unit to 50  $\Omega$ .
- When the input resistance is set to 50 $\Omega$ , the VSWR (voltage standing wave ratio) becomes 1.35 or less, where a waveform with few reflection can be observed.

FOR 50  $\Omega$ , KEEP ON PRESSING



### Cautions

When the input resistance is set to 50  $\Omega$ , do not apply too large signals of 5 Vrms or more.

When a DC voltage of  $\pm 10$  V or more has been detected, the following message is displayed for safety and the setting changes from 50  $\Omega$  to 1 M $\Omega$ .

“INPUT OVERLOADED AND REVERTED TO 1 M $\Omega$ ”

## 2.5.4 Display channels

Signals input to CH1, CH2, CH3 or CH4 are displayed.

### Operating method

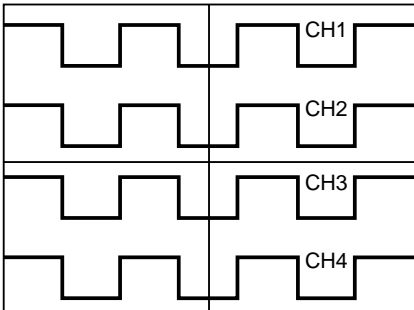

### Procedures

Select **ON (display)** or **OFF (non-display)** of each channel by pressing **CH1**, **CH2**, **CH3** or **CH4**.

- ← An example where **CH1**, **CH2**, **CH3** and **CH4** are set to ON is shown on the left.

◇ The signals applied to INPUT of the channels set to ON are displayed on the screen. The signal applied to a channel that is set to OFF disappears from the screen.

- ← ◇ The channel No., VOLTS/DIV, and input coupling of the channels set to ON are displayed in the lower left corner of the screen. Those of a channel that is set to OFF disappear from the screen.

[Note] When all channels (CH1, CH2, CH3, CH4 and ADD) are set to OFF, CH1 is displayed.

## 2.5.5 ALT and CHOP

Select the display mode (ALT, CHOP) when two or more channels are displayed.

### Operating method

### Procedures

Select two or more channels from CH1, CH2, CH3 and CH4 (refer to “2.5.4 Display Channels”).

Select **ALT** or **CHOP** (the indicator lights) by pressing **ALT CHOP**.

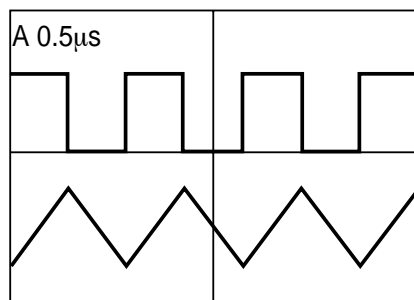

- ← ◇ **ALT (alternate)**
  - Two or more input signals are swept alternately.
  - This mode is suitable for observing high-frequency signals on two or more channels.

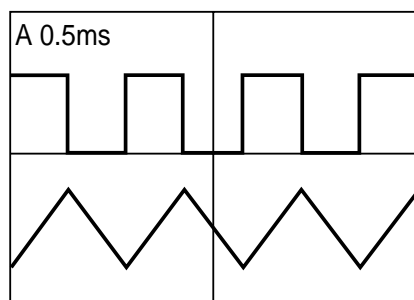

- ← ◇ **CHOP (chop)**
  - Two or more input signals are switched at frequency of approx. 555 kHz.
  - This mode is suitable for observing low-frequency signals on two or more channels.

### 2.5.6 Sum and difference

Add two channels (CH1 + CH2) or subtract one channel from another (CH1 - CH2). Addition or subtraction can be selected by selecting ADD and then setting INV.

#### Operating method

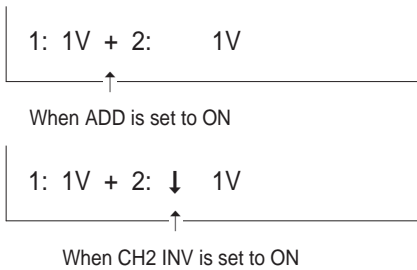

#### Procedures

**Set CH1 and CH2 to ON (display) (refer to “2.5.4 Display Channels”).**

**Set ADD to ON by pressing **ADD** (“+” is displayed in the lower left corner of the screen).**

- A waveform in which two signals are added (CH1 + CH2) is displayed on the screen.

**Set INV to ON by pressing **INV** (“↓” is displayed in the lower left corner of the screen).**

- The polarity of CH2 is inverted and a waveform in which one signal is subtracted from another (CH1 - CH2) is displayed on the screen.

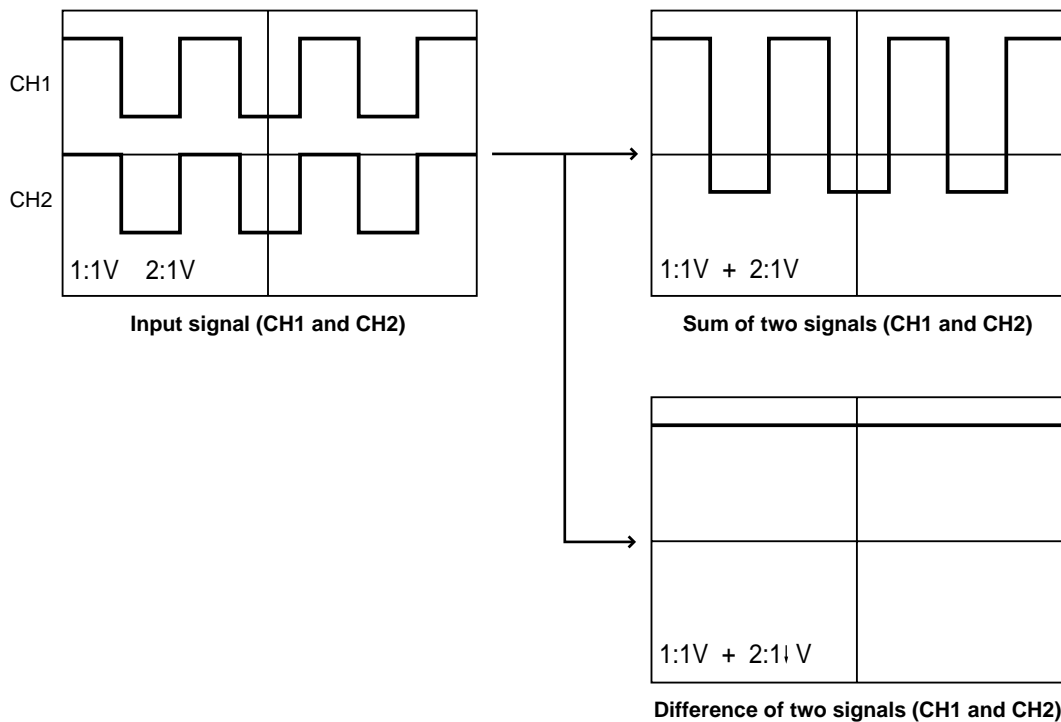

### 2.5.7 Bandwidth limiter

When observing those signals containing much high-frequency noises, the noises can be suppressed. However the frequency band is limited to about 20 MHz or about 100 MHz.

#### Operating method



#### Procedures

**Select 100, 20, or OFF by pressing **BWL** .**

- The bandwidth is displayed in the lower right corner of the screen. There is no display when OFF is selected.
  - 100 : The bandwidth is limited to 100 MHz.
  - 20 : The bandwidth is limited to 20 MHz.
  - OFF : No limitation is imposed on the bandwidth.



## 2.5.8 Offset

### 2.5.8.1 CH1/CH2 offset

This is the function to adjust the CH1/CH2 offset voltage.

#### Operating method

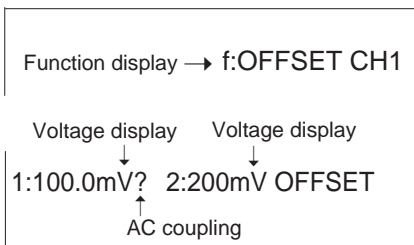
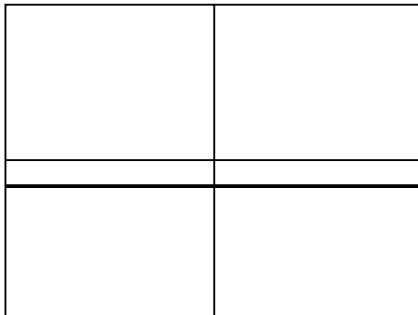

#### Procedures

##### Selecting the reference position

Set GND to ON by pressing **GND** (refer to “2.5.2. Input Coupling”).

Set the reference position for offset by turning **[▲POSITION▼]**.

- An example of setting the reference position is shown on the left.

##### Selecting the offset voltage

Set GND to OFF by pressing **GND**.

Select DC by pressing **DC/AC**.

Select **OFFSET CH1/CH2** by pressing **OFFSET**.

- Function display changes into f:OFFSET CH1.

Set the offset **VOLTAGE (CH1/CH2)** by turning **[FUNCTION]**.

- The reference position set in procedure becomes the offset voltage value.
- When the input coupling is set to AC, the display is followed by ?.
- The display of trigger level does not include the offset value.

##### ◇ Selecting the object channel

The channel as the object of setting (CH1 or CH2) can be selected by pressing **ATTACH**.

##### ◇ Releasing CH1/CH2 offset

Select OFF (without the display of OFFSET) by pressing **OFFSET**.

#### FET probe

A probe with an FET attached to the tip is called an active probe.

- This is a probe with a high impedance and low input capacitance.
- When a probe for common oscilloscopes is connected, the circuit under measurement may be affected (such as oscillation) by the input capacitance of the probe. In this case, the effect on the circuit under measurement can be suppressed by the use of an FET probe.
- Main performance of the SPF-5A/4A probe are as follows:
 

|                   |  |
|-------------------|--|
| Input impedance   | : 1 MΩ, approx. 1.9 pF (SFP-5A)/1 MΩ, approx. 2.15 pF (SFP-4A) |
| Attenuation ratio | : 10:1   |
| Bandwidth         | : DC to 1 GHz (SFP-5A)/DC to 800 MHz (SFP-4A)                  |

## 2.5.8.2 PROBE P1/P2 offset

This is the function to set the offset voltage of the FET probe to be connected to the PROBE POWER terminal (P1/P2) of this unit.

### Operating method

No function display → 

Function display → f:SYS-MENU

PROBE OFFSET DISABLE  
ENABLE: [NORM] EXIT: [SGL/RST]

### Procedures

#### Selecting on SYS-MENU

← **Set all function to OFF and set the [FUNCTION] key to the invalid state \*1.**

\* 1The state where f:XXXXX is not displayed on the upper right corner of the screen.

**Select OFF (non-display) by pressing [READOUT] .**

← **Press [FUNCTION] for 3 sec, then the system menu (SYS-MENU) is displayed.**

**Select PROBE OFFSET by turning [FUNCTION] .**

• The message on the left is displayed at the center of the screen.

• ENABLE/DISABLE can be switched alternately by pressing **[NORM]** .

ENABLE : The offset voltage can be set.

DISABLE : The offset voltage cannot be set.

**Select ENABLE by pressing [NORM] .**

#### Releasing SYS-MENU

**Release the system menu by pressing [SGL/RST] .**

#### Setting PROBE offset

Function display → f:OFFSET P1

Percent display      Percent display  
↓                              ↓  
P1:100.0%    P2:20.00%    OFFSET

← **Select OFFSET P1/P2 by pressing [OFFSET] twice.**

• Function display changes into f:OFFSET P1.

← **Set the offset voltage (P1/P2) by turning [FUNCTION] .**

• This is the ratio (%) to the offset variable range of the FET probe.

• This is valid with the SFP-5A/4A probe made by Iwatsu.

#### ◇ Selection of the object terminal

The terminal as the object of setting (P1 or P2) can be selected by pressing **[ATTACH]** .

◇ **Once procedures to have been performed, they may be omitted on the next and following occasions. The settings are maintained after power has been turned off.**

◇ **Refer to page 20 for the FET probe.**

## 2.6 A Sweep and B Sweep

This is the function to select A sweep or B sweep.

### Operating method

### Procedures

Select A or B by pressing **A B** .

- The indicator lights when B is selected.

A : For setting the sweep rate and trigger for normal sweep

B : For setting the sweep rate and trigger for delayed sweep

|   | Sweep rate | Signal source | Slope | Coupling | Level |
|---|------------|---------------|-------|----------|-------|
| A | 5ms        | CH1           | +     | DC       | 200mV |
| B | 1ms        | CH1           | -     | AC       | 20mV  |

← ◇ **Select A for setting the following items.**

- A sweep rate
- Trigger signal source for A trigger
- Trigger slope for A trigger
- Trigger coupling for A trigger
- Trigger level for A trigger

|   |     |     |   |    |       |
|---|-----|-----|---|----|-------|
| A | 5ms | CH1 | + | DC | 200mV |
| B | 1ms | CH1 | - | AC | 20mV  |

↑ Signal source      ↑ Slope      ↑ Coupling      ↑ Level  
 Sweep rate

← ◇ **Select B for setting the following items.**

- B sweep rate
- Trigger signal source for B trigger
- Trigger slope for B trigger
- Trigger coupling for B trigger
- Trigger level for B trigger

## 2.7 Sweep Rate and Magnification

### 2.7.1 Sweep Rate

Select the sweep rate (TIME/DIV) of A sweep or B sweep.

#### Operating method

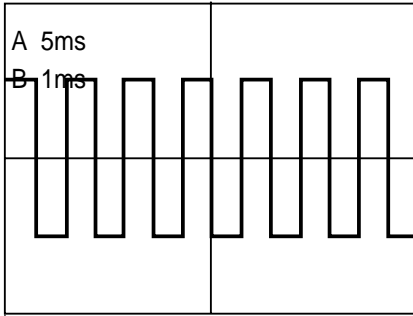

Sweep start point (for magnification/reduction reference point)

#### Procedures

Selecting *A/B sweep*

Select A sweep or B sweep (the indicator lights) by pressing **A B**.

#### Setting the TIME/DIV

Select the sweep rate by turning **[TIME/DIV]**.

- The sweep rate is displayed in the upper lefthand corner of the screen.
- The waveform is magnified or reduced on the basis of the sweep start point.
- Proceed to step for performing fine adjustment (on A sweep rate alone).

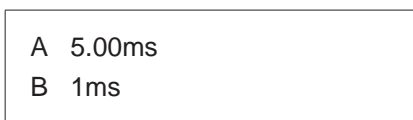

#### Setting the VARIABLE

Press **[TIME/DIV]**; the uncalibrated “>” sweep rate is displayed in the upper left corner of the screen.

Turn **[TIME/DIV]**; the sweep rate varies continuously between steps.

- “VAR LIMIT” is displayed when the set value reaches the maximum or minimum value.
- To release the variable setting mode, press **[TIME/DIV]** again to delete “>”.

### 2.7.2 Magnification (MAG x 10)

Magnify the waveform by 10 times as the reference on the center line.

#### Operating method

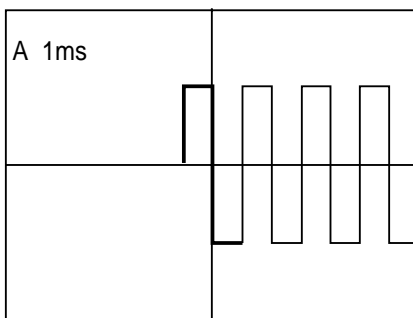

Center line (magnification reference point)

#### Procedures

Set the sweep rate using **[TIME/DIV]**. (refer to “2.7.1 Sweep Rate”).

Set the position of the waveform to be magnified to the center of the screen.

- The portion indicated by thick lines is magnified.

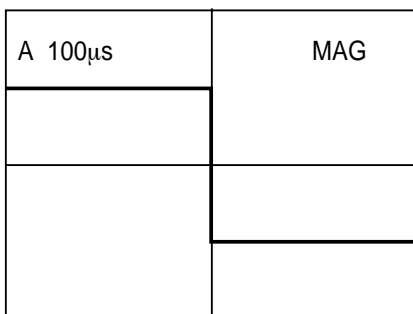

Press **x 10 MAG**.

- The sweep rate is increased by 10 times and the waveform is magnified to the left and right from the center line of the screen.
- MAG is displayed in the lower right corner of the screen.

### 2.7.3 CH2 Delay Adjust (CH2 DLY)

When measuring the time difference between two channels (CH1 and CH2), preliminary adjustment of the time lag between channels enables highly accurate measurement. The lag of delay time including the two connection cables or probes can also be adjusted.

#### Connection

Connect cables as follows:

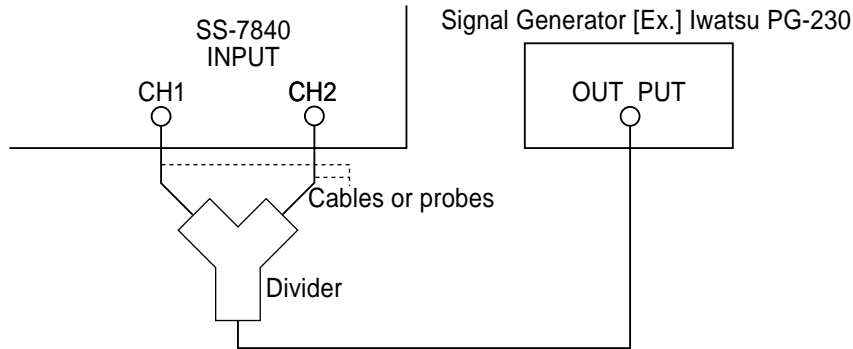

#### Operating method

##### Procedures

Turn on the display of CH1 and CH2.

Connect a pulse with a rise time faster than 5 ns to both channels.

Set A sweep rate to 5 ns/div or 500 ps/div (x 10 MAG ON).

Select ALT by simultaneously pressing **[A]** and **[B]** of HORIZ DISPLAY.

- The screen displays A sweep alone.

Adjust the waveform of CH2 to that of CH1 by turning **[FUNCTION]**.

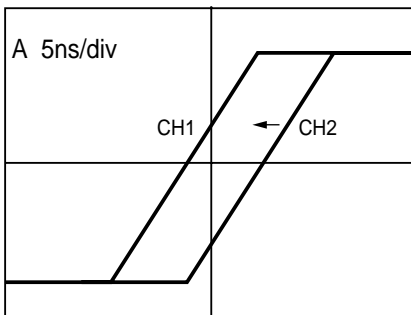

← ◇ **Waveform before the adjustment**  
Adjust the waveform of CH2 to that of CH1.

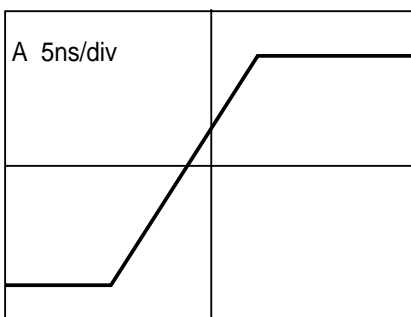

← ◇ **Waveform after the adjustment**

## 2.8 Sweep Mode

Select the sweep mode (AUTO, NORM, or SINGLE).

### 2.8.1 Repetitive sweep

Select AUTO or NORM.

#### Operating method

##### Procedures

**Select repetitive sweep by pressing **AUTO** or **NORM** in the SWEEP MODE.**

- The AUTO indicator lights when AUTO is selected and NORM indicator, when NORM is selected.
- If triggering is not set, set triggering by adjusting **【TRIG LEVEL】**, etc.  
Refer to “2.9 Triggering” for details.

#### **AUTO (automatic sweep)**

- Take triggering by adjusting the trigger level. If no triggering is set, automatic sweep takes place.
- When the frequency of the trigger signal is approx. 10 Hz or less at a sweep time between 500 ms and 10 ms/DIV, or approx. 50 Hz or less at a sweep time of 5 ms/DIV or more, triggering may become unstable. In this case, take triggering by NORM.

#### **NORM (normal sweep)**

- Take triggering by adjusting the trigger level. If no triggering is set, no sweep occurs.
- Only when the trigger source is CH1 or CH2 and the input coupling is GND at the same time, automatic sweep takes place.

With this function, the position of GND can be confirmed easily.

### 2.8.2 Single sweep

Select single sweep.

#### Operating method

##### Procedures

**Select single sweep by pressing **SGL/RST** in the SWEEP MODE (the SGL/RST indicator lights).**

- The READY indicator lights to indicate the state waiting for signal input.

◇ Sweep is effected once when a trigger signal is generated.

- The READY indicator goes off.
- In the CHOP mode, all channels are swept simultaneously.
- In the ALT mode, only one channel is swept.

② **To perform another single sweep, press **SGL/RST** again.**

## 2.9 Triggering

This is the operation to enable observation of input signals in a stable state on the screen.

### 2.9.1 Trigger Source

Select the trigger source.

#### Operating method

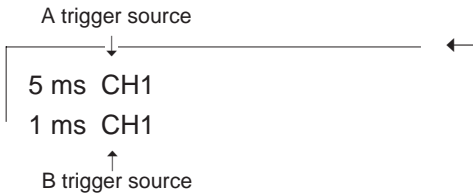

#### Procedures

**Select A sweep or B sweep (the indicator lights) by pressing **AB**.**

- B trigger is set when performing a delayed sweep (refer to “2.12 Delayed Sweep”).

**Select the trigger source (CH1, CH2, CH3, or LINE) by pressing **SOURCE**.**

- Line is for A sweep alone.

CH1 : Use the signal input to CH1 as the trigger source.

CH2 : Use the signal input to CH2 as the trigger source.

CH3 : Use the signal input to CH3 as the trigger source.

CH4 : Use the signal input to CH4 as the trigger source.

LINE (for A sweep alone) : The power source is used as the trigger source. This is suitable for observation of signals triggered with the power frequency.

### 2.9.2 Trigger Coupling

Select the trigger coupling.

#### Operating method

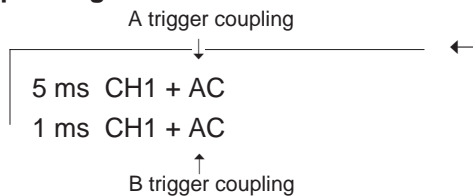

#### Procedures

**Select A sweep or B sweep (the indicator lights) by pressing **AB**.**

- B trigger is set when performing a delayed sweep (refer to “2.12 Delayed Sweep”).

**Select the trigger coupling (AC, DC, HF REJ, or LF REJ) by pressing **COUPL**.**

AC : Blocks the DC component of the trigger signal. The lower limit of frequency is 100 Hz.

DC : Pass all the signal components.

HF REJ : Attenuates the high frequency component (above 10 kHz). This mode is used when high-frequency noises are contained in the trigger source and the trigger may become unstable due to such noises.

LF REJ : Attenuates the low frequency component (below 10 kHz). This mode is used when low-frequency noises (hum of power frequency, etc.) are contained in the trigger source and the trigger may become unstable due to such noises.

### 2.9.3 Trigger Slope (SLOPE)

Select the trigger slope.

#### Operating method

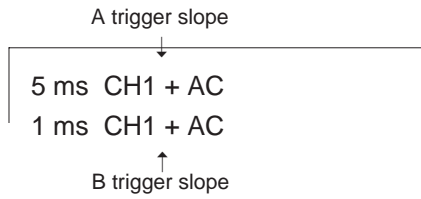

#### Procedures

Select A sweep or B sweep (the indicator lights) by pressing

**AB**.

- B trigger is set when performing a delayed sweep (refer to “2.12 Delayed Sweep”).

Select the slope (+ or -) by pressing **SLOPE**.

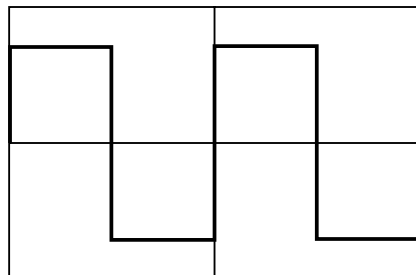

(Sweep starts at the rising edge of the waveform.)

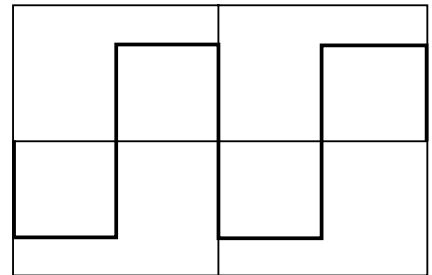

(Sweep starts at the falling edge of the waveform.)

### 2.9.4 Trigger Level

Adjust the amplitude point on the trigger level.

#### Operating method

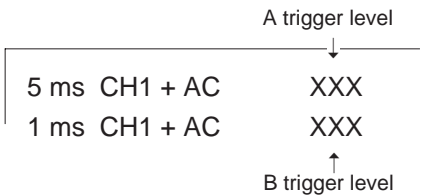

#### Procedures

Select A sweep or B sweep (the indicator lights) by pressing

**AB**.

- B trigger is set when performing a delayed sweep (refer to “2.12 Delayed Sweep”).

Adjust the trigger level by tuning **TRIG LEVEL**.

- The TRIG'D indicator lights when the trigger signal is generated.
- Sometimes “?” is displayed to the right of the value displayed. This indicates that direct reading is impossible if AC coupling or VARIABLE is set.

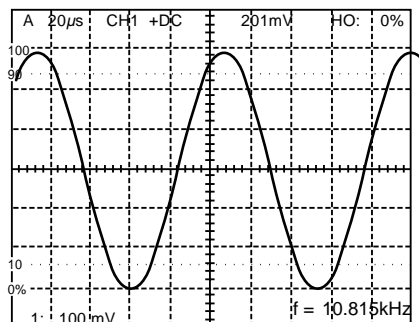

Turning **TRIG LEVEL** to right from the midrange

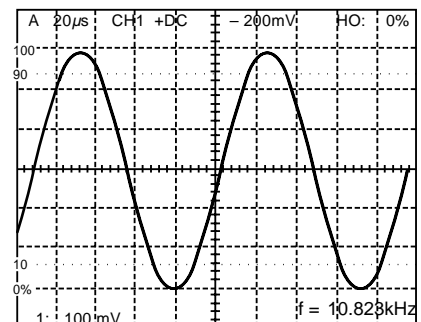

Turning **TRIG LEVEL** to left from the midrange



## 2.9.5 TV Signal

### 2.9.5.1 TV signal modes and the number of lines

This is the function to set the TV signal mode and the number of lines.

#### Operating method

#### Procedures

Select the TV trigger mode (BOTH, ODD, EVEN, or TV-H) by pressing **TV**.

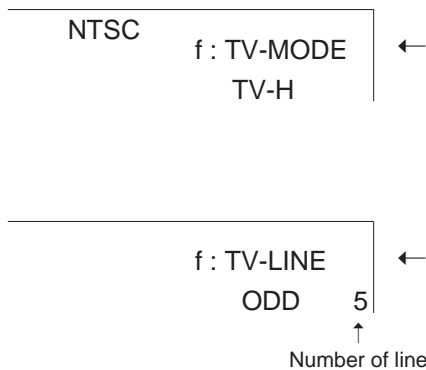

#### ◇ When TV-H is selected

- The function display changes into f:TV-MODE.

Select NTSC, PAL (SECAM), or HDTV by turning **FUNCTION**.

- Refer to “Table 2.9.1 TV modes and their features” for the details of TV modes.

#### ◇ When BOTH, ODD, or EVEN is selected

- The function display changes into f:TV-LINE.

Select the line number by turning **FUNCTION**.

- Coarse adjustment in the direction it has so far been turned can be effected each time **FUNCTION** is pressed or when it is pressed continuously.
- The allowable range of setting is shown in “Table 2.9.2 Number of lines that can be set”.
- Operate the procedure when ODD or EVEN is selected.

Select either ODD or EVEN by pressing **COUPL**.

- ODD and EVEN waveform can be observed on the field by switching them mutually while selecting the line number.

- ODD : Triggering is set by selecting the number of horizontal synchronization signal from the vertical synchronization signals of odd-numbered fields.
- EVEN : Triggering is set by selecting the number of horizontal synchronization signal from the vertical synchronization signals of even-numbered fields.
- BOTH : Triggering is set by selecting the number of horizontal synchronization signal from the vertical synchronization signals of odd-numbered or even-numbered fields.
- TV-H : Triggering is set on a horizontal synchronization pulse.
- OFF : The TV mode is released.

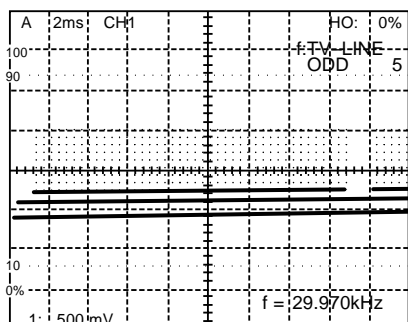

Triggering on a vertical synchronization pulse

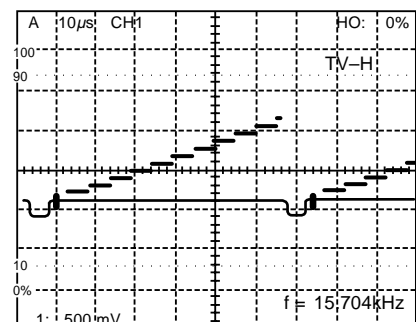

Triggering on a horizontal synchronization pulse

Table 2.9.1 TV modes and their features

| Mode  | Number of scanning lines | Field frequency | Video signal bandwidth | Countries in which the mode is used | Remarks              |
|-------|--------------------------|-----------------|------------------------|-------------------------------------|----------------------|
| NTSC  | 525                      | Approx. 60 Hz   | 4.2 MHz                | U.S.A., Canada, Japan               |                      |
| SECAM | 625                      | Approx. 50 Hz   | 6 MHz                  | France, Russia                      |                      |
| PAL   | 625                      | Approx. 50 Hz   | 5 MHz                  | Europe, etc.                        |                      |
| HDTV  | 1125                     | Approx. 60 Hz   | 20 MHz                 |                                     | High definition type |

Table 2.9.2 Number of lines that can be set

| Mode        | Number of lines |          |             |
|-------------|-----------------|----------|-------------|
|             | BOTH            | ODD      | EVEN        |
| NTSC        | 1 to 525        | 1 to 263 | 264 to 525  |
| PAL (SECAM) | 1 to 625        | 1 to 313 | 314 to 625  |
| HDTV        | 1 to 1125       | 1 to 563 | 564 to 1125 |

[Note] NTSC displays with the M mode and PAL (SECAM), with other modes than M.

M mode : Sequential numbers are assigned to scanning lines beginning with that just after the start of the vertical blanking period of each field.

Other modes than M : The start point is set to the beginning of the vertical synchronizing signal of the first field.

### 2.9.5.2 TV Clamp

This is the function to clamp the back porch section of composite signals to the reference level (ground level). This procedure enables stable observation of those TV signals of which the average voltage fluctuates.

#### Operating method

#### Procedures

**Select the Formats by pressing **TV** .**

- Refer to “2.9.5.1 TV signal modes and the number of lines” for TV modes.

**Select the clamp (CLAMP CH1, CLAMP CH2, OFF) by pressing **EVENT/TV CLAMP** .**

- The selected clamp is displayed at the bottom of the screen. Shows the example of CLAMP CH1.  
 CLAMP CH1 : CH1 is clamped.  
 CLAMP CH2 : CH2 is clamped.  
 OFF : Clamp is released.

CLAMP CH1 ←

[Note 1] During the V synchronizing period of HDTV, waveform may be distorted due to the disabled clamp operation.

[Note 2] The reference level may not become stable if the TV signals are not synchronized.

#### Back porch

The position of the back porch is shown in the figure on the right. Because the waveform is displayed with its back porch clamped to the ground level, a stable observation of fluctuating signals can be obtained.

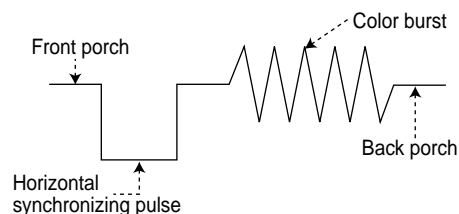

## 2.9.6 Event Trigger

This is the function to select the event trigger (count or burst).

### Operating method

#### Procedures

##### Set the Formats to OFF.

- Refer to “2.9.5.1 TV signal modes and the number of lines” for the setting method.

##### Select COUNT, BURST, or OFF by presing

**EVENT/TV CLAMP** .

- Operations in and after procedure vary depending on the item selected.

f:EVENT  
COUNT nnnn

##### ← When COUNT was selected

- Function display changes into f:EVENT.

##### Set the number of counts by turning **[FUNCTION]** .

- The range of the number of counts that can be set is 1 to 65535.
- Refer to the following page for the details of count trigger.

f:EVENT  
BURST n.nns

##### ← When BURST was selected

- Function display changes into f:EVENT.

##### Set the Burst signal interval by turning **[FUNCTION]** .

- The range of the time that can be set is 0.18  $\mu$ s to 9.99 s.
- Refer to the following page for the details of burst trigger.

##### ← When OFF was selected

- Function display does not appear.

### Count

Triggering is set when the specified number of B trigger signals have been counted after the occurrence of A trigger.

This function is suitable for confirming the operation of a counter circuit and so on.

[Example] An example where the count is set to 6 is shown in the figure below.

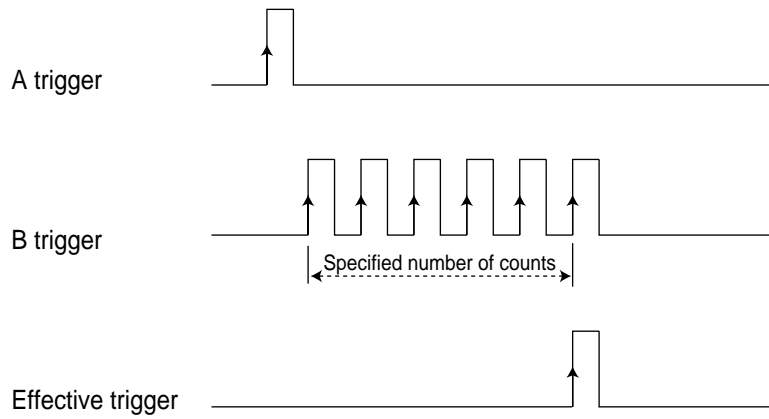

### Burst

When the time interval of A trigger exceeds the specified length of time, the next A trigger is deemed as the effective trigger.

This function is suitable for observing a burst waveform.

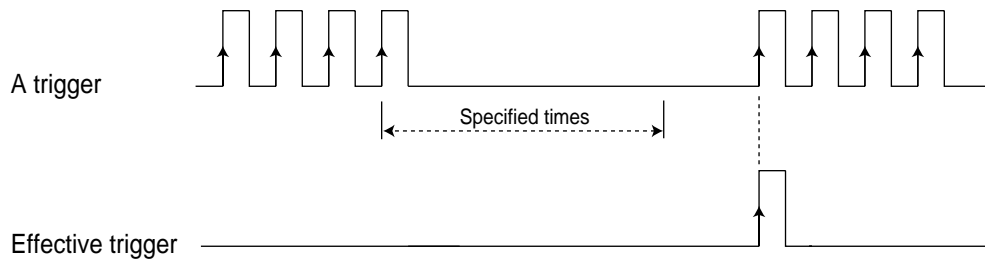

## 2.10 Horizontal Display

Select the horizontal display.

### Operating method

#### Procedures

Select A, B, ALT, or X-Y by pressing **A**, **B**, or **X-Y** in the **HORIZ DISPLAY** mode.

- To select ALT, press **A** and **B** simultaneously.

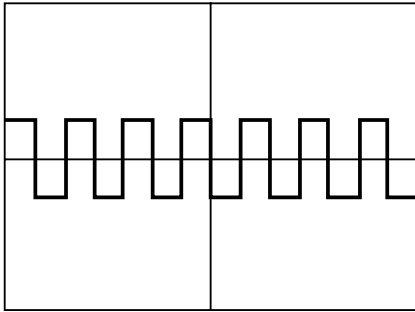

- ← **◇ A**  
A sweep is displayed.

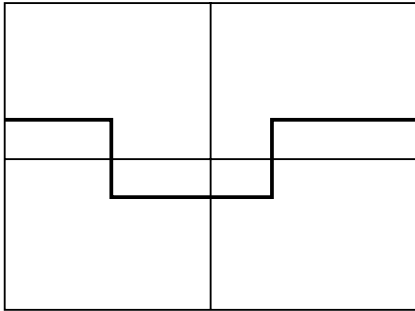

- ← **◇ B**
- B sweep (magnified waveform in ALT) is displayed.
  - Refer to “2.12 Delayed Sweep” for details.

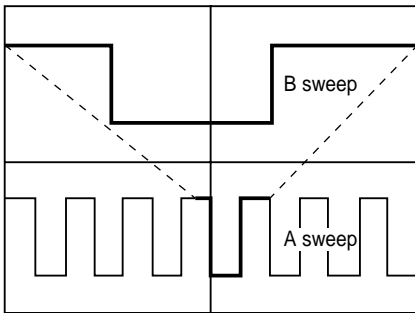

- ← **◇ ALT**
- A sweep (not magnified waveform) and B sweep (magnified waveform) are displayed simultaneously.
  - Refer to “2.12 Delayed Sweep” for details.
  - Vertical position of B sweep can be adjusted. B sweep is moved upward with respect to A sweep (refer to “2.11 Trace Separation”).

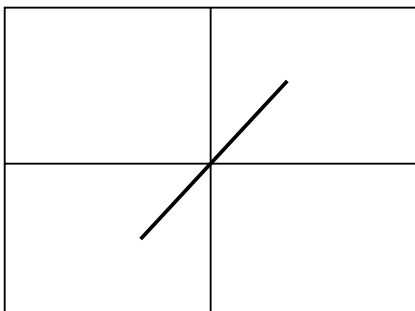

- ← **◇ X-Y**
- An X-Y display in which CH1 input is taken on the X axis and each channel (CH1, CH2, CH3, CH4, ADD) is taken on the Y axis is obtained.
  - This mode is used for observation of hysteresis curves, Lissajous waveforms, etc.

## 2.11 Trace Separation

During ALT sweep, move the B-sweep waveform to a position suitable for observation.

### Operating method

#### Procedures

##### Selecting ALT sweep

Select ALT by pressing **[A]** and **[B]** in the **HORIZ DISPLAY** mode.

- A-sweep waveform and B-sweep waveform are displayed so that one is laid upon the other.

A sweep: ———

B sweep: - - - - -

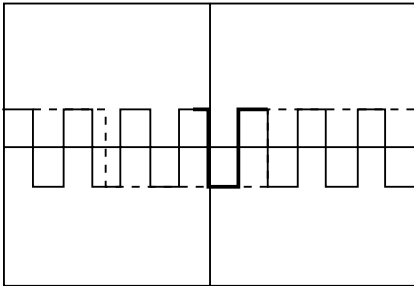

##### Moving the position of A and B waveform

Move the position of waveform to the lower area of the screen by turning **[ΔPOSITION]**.

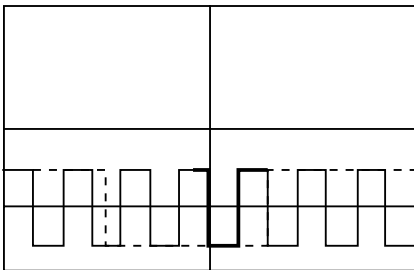

##### Selecting TRACE SEP

Select **TRACE SEP** by pressing **[DELAY/TRACE SEP]**.

- The function display changes into **f : TR-SEP**.



##### Moving B waveform

Move the vertical position of the B-sweep waveform by turning **[FUNCTION]** (only upward movement is available).

- Coarse adjustment in the direction it has so far been turned can be effected each time **[FUNCTION]** is pressed or when it is pressed continuously.

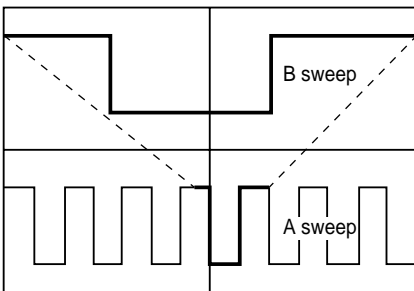

## 2.12 Delayed Sweep

Select the delayed sweep mode (continuous delay, triggered delay).

### 2.12.1 Continuous Delay

B sweep starts after a specified delay time has elapsed from the sweep start point of A sweep. The desired portion of the waveform displayed can be displayed in magnified form. This function is valid when HORIZ DISPLAY is set to ALT or B.

#### Operating method

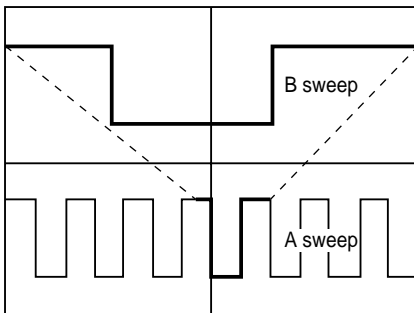

#### Procedures

##### Selecting ALT sweep

Select ALT by pressing **A** and **B** in the HORIZ DISPLAY mode.

- A sweep and B sweep are displayed.
- The intensity-modulated portion of A sweep (in the lower area of the screen) is magnified and displayed as B sweep (in the upper area of the screen).
- A sweep and B sweep are separated from each other for convenience of explanation. For the method of separation, refer to "2.11 Trace Separation".

##### Selecting the B-sweep rate

Select B by pressing **A B** (the B indicator lights).

Select the B-sweep rate by turning **[TIME/DIV]**.

- The ratio between A sweep and B sweep varies.
- The B-sweep rate cannot be set to a value slower than the A-sweep rate.

##### Selecting of continous delay

Select the screen with no display of trigger source B by pressing **SOURCE**.

##### Selecting the delay time

Select DELAY by pressing **DELAY/TRACE SEP**.

- Function display changes into f : B-DELAY

A 5ms CH1 + DC A level  
 B 1ms    ↑ - AC B level  
 No display of trigger source B

Delay time → DLY nnn  
 Function display → f : B-DELAY

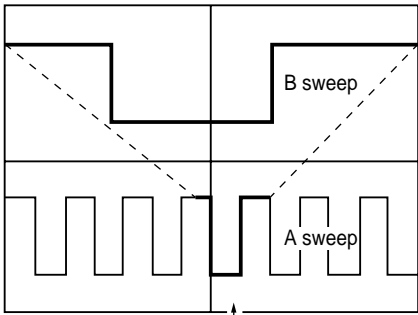

The intensity modulated portion moves continuously

← **Adjust the delay time by turning [FUNCTION] .**

- Coarse adjustment in the direction it has so far been turned can be effected each time [FUNCTION] is pressed or when it is pressed continuously.
- Proceed to step when performing B ENDS A.

**Selecting B ENDS A**

Select **[HOLDOFF]** by pressing **HOLDOFF**.

- For details of HOLDOFF, refer to "2.13 Holdoff".

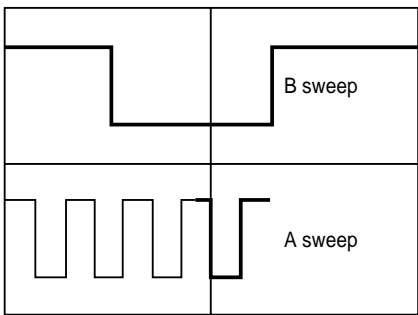

← **Set the hold-off time to a value larger than 100% by turning [FUNCTION] ; the B ENDS A mode is set.**

- B ENDS A  
The portion of A sweep following the intensity-modulated portion (B sweep) is deleted. The frequency of sweep increases in proportion to the length of the deleted time and the intensity increases.



## 2.12.2 Triggered Delay

B sweep starts at the trigger point of B sweep after a specified delay time set from the sweep start point of A sweep. Although the delay pick off jitter can be reduced in this mode, the start point of B sweep is limited to the B trigger point.

### Operating method

A 5ms CH1 + DC A level  
 B 1ms CH1 - AC B level  
 ↑  
 Trigger source B

Delay time → DLY> nnn  
 Function display → f : B-DELAY

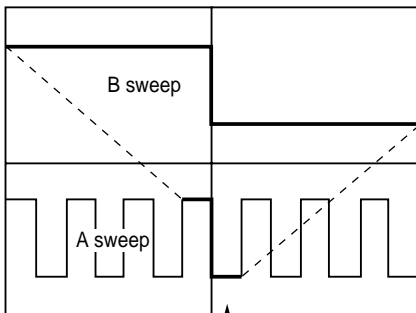

The intensity-modulated portion moves to the next trigger point.

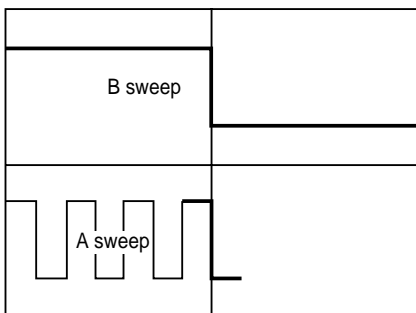

### Procedures

to Same as those in “2.12.1 Continuous Delay”.

### Selecting of trigger delay

← Select trigger source B by pressing **SOURCE** .

### Triggering of B sweep

Take triggering of B sweep.

- The method for taking triggering is the same as that for A sweep (refer to “2.9 Triggering”).

### Selecting the delay time

← Select **DELAY** by pressing **DELAY/TRACE SEP** .

- Function display changes into f : B-DELAY.

Adjust the delay time by turning **[FUNCTION]** .

- Coarse adjustment in the direction it has so far been turned can be effected each time **[FUNCTION]** is pressed or when it is pressed continuously.
- Although the DLY value varies continuously in the case of trigger delay, it is not in accord with the actual delay time. “<” is attached to the DLY value.
- Proceed to step when performing B ENDS A.

### Selecting B ENDS A

Select **HOLDOFF** by pressing **HOLDOFF** .

- For details of HOLDOFF, refer to “2.13 Holdoff”.

Set the hold-off time to a value larger than 100% by turning **[FUNCTION]** ; the B ENDS A mode is set.

- B ENDS A  
 The portion of A sweep following the intensity-modulated portion (B sweep) is deleted. The frequency of sweep increases in proportion with the length of the deleted time and the intensity increases.

The figure below shows the time relations for the case where CH2 is specified as the trigger source for B sweep in the triggered delay mode.

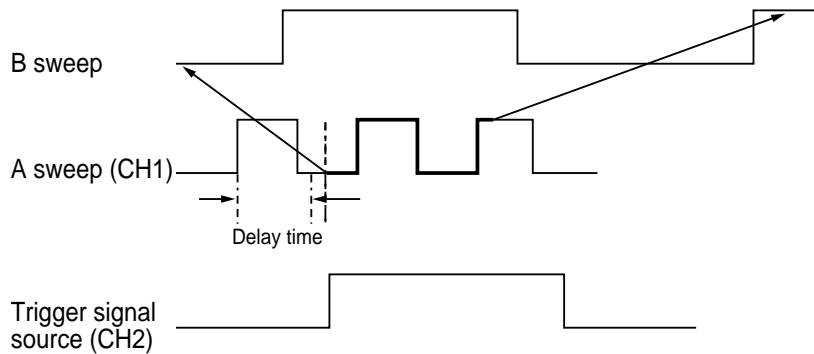

## 2.13 Holdoff

Sometimes triggering cannot be set in a stable manner when observing a pulse train made of complex combinations. In this case, adjust the holdoff (sweep pause) time so that a stable waveform can be obtained.

### Operating method

HO : nn%  
f : HOLDOFF

### Procedures

Select **HOLDOFF** by pressing **HOLDOFF** .

- Function display changes into f : HOLDOFF.

Adjust the holdoff time by turning **[FUNCTION]** .

- Coarse adjustment in the direction it has so far been turned can be effected each time **[FUNCTION]** is pressed or when it is pressed continuously.
- The holdoff time becomes the maximum value (100%) when **[FUNCTION]** is fully turned clockwise, and the minimum value (0%) when fully turned counterclockwise.
- Usually, the holdoff time is set to 0%.

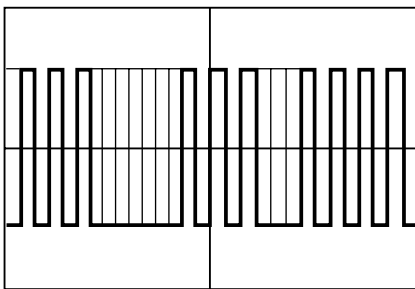

Waveform before adjustment (duplicated display)

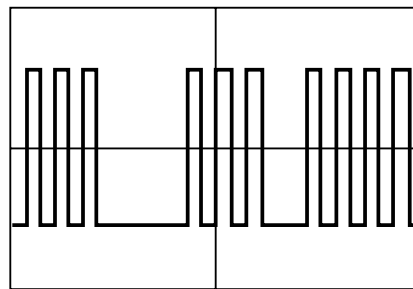

Waveform after adjustment

### Adjustment of the hold-off (sweep halting) time

Adjust the interval from a trigger point to the waiting start point of the next trigger (hold-off time) so as to prevent any triggering from being set by an unnecessary pulse.

## Section 3. Cursors Measurement and Counter

Measure the time difference and frequency ( $\Delta t$ ,  $1/\Delta t$ ) or voltage difference ( $\Delta V$ ) using cursors.

### ◇ Selecting of the measurement item

- Select  $\Delta V$  (voltage measurement) by pressing  $\Delta V$  or select  $\Delta t$  (time measurement) by pressing  $\Delta t$ .

### ◇ Methods for measurement using cursors.

- When  $\Delta t$  or  $\Delta V$  has been selected, two cursors for measurement are displayed.
- Adjust the cursor positions by turning **[FUNCTION]**. Coarse adjustment in the direction it has so far been turned can be effected each time **[FUNCTION]** is pressed or when it is pressed continuously.

### 3.1 Time Difference ( $\Delta t$ ) and Frequency ( $1/\Delta t$ ) Measurement

Measure the time difference ( $\Delta t$ ) and frequency ( $1/\Delta t$ ) between the cursors.

#### Operating method

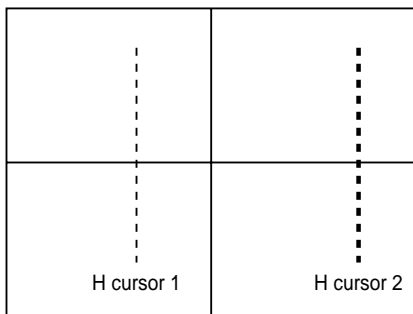

#### Procedures

- ← **Select  $\Delta t$  by pressing  $\Delta t$ .**
  - H cursor 1 and H cursor 2 are displayed.
  - The results of measurement of  $\Delta t$  (time difference) and  $1/\Delta t$  (frequency) between cursor 1 and cursor 2 are displayed in the lower left corner of the screen.
  - Move cursor 1 and cursor 2 to the measurement points and then perform measurement.

#### Setting cursor 1

- ← **Select C1 (cursor 1) by pressing TCK/INDEP.**
  - The function display changes into f : H-C1.

Symbol representing a cursor movement

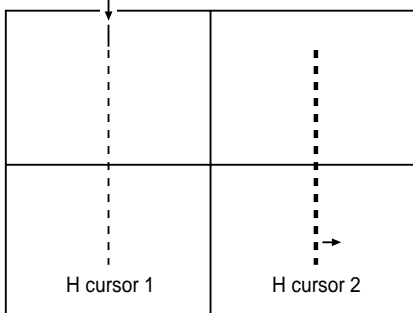

- ← • Symbol "I" displayed above H cursor 1 indicates that H cursor 1 is movable.

**Move H cursor 1 (I) to the other measurement point by turning.**

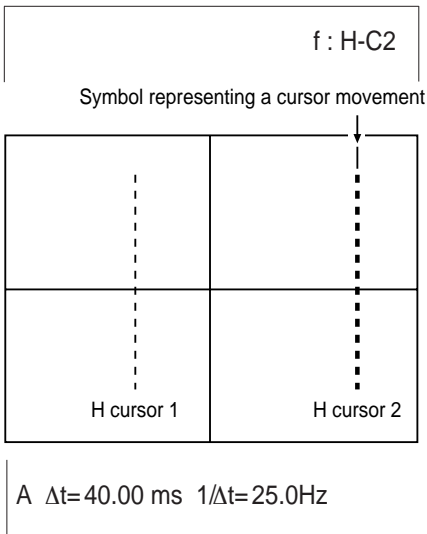

### Setting cursor 2

- ← **Select C2 (cursor 2) by pressing TCK/INDEP .**
    - The function display changes into f : H-C2.
  - ← • Symbol “ I ” appears above H cursor 2 indicating that cursor 2 is movable.
- Move H cursor 2 ( I ) to the other measurement point by turning FUNCTION .**
- ← • The results of measurement of  $\Delta t$  (time difference) and  $1/\Delta t$  (frequency) between newly set cursor 1 and cursor 2 are displayed in the lower left corner of the screen.

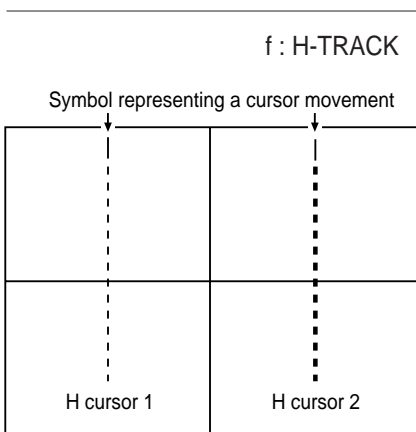

### Setting the tracking

- ← **Select TCK (tracking) by pressing TCK/INDEP .**
    - Function display changes into f:H-TRACK.
  - ← • Symbol “ I ” appears above H cursor 1 and H cursor 2 indicating that both cursors are movable.
- Turn FUNCTION , then H cursor 1 and H cursor 2 move together while maintaining the interval between them.**
- ◇ **Releasing  $\Delta t$  measurement**  
 Select OFF (no cursor display) by pressing  $\Delta t$  .

## 3.2 Voltage Difference ( $\Delta V$ ) Measurement

Measure the voltage between the cursors.

### Operating method

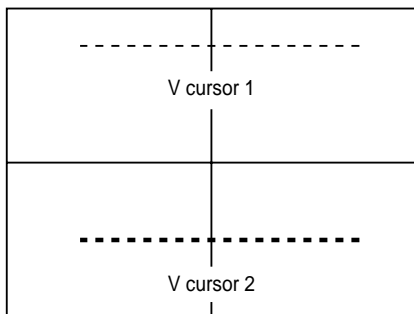

f : V-C1

Symbol representing a cursor movement

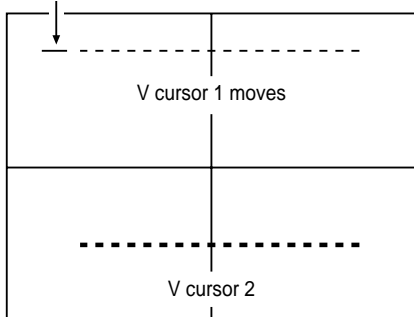

f : V-C2

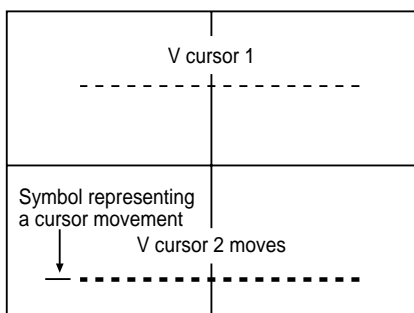

$\Delta V1=59.2 \text{ mV}$   $\Delta V2= -0.592 \text{ Hz}$

### Procedures

← Select  $\Delta V$  by pressing  $\Delta V$ .

- V cursor 1 and V cursor 2 are displayed.
- The results of measurement of  $\Delta V1$  (CH1) and  $\Delta V2$  (CH2) between cursor 1 and cursor 2 are displayed in the lower lefthand corner of the screen.
- Move cursor 1 and cursor 2 to the measurement points and then perform measurement.

### Setting cursor 1

← Select V-TRACK by pressing TCK/INDEP.

- The function display changes into f : V-C1.

← • Symbol “ ” appears to the left of V cursor 1 indicating that V cursor 1 is movable.

**Move V cursor 1 ( ---- ) to a measurement point by turning [FUNCTION] .**

- V cursor 1 and V cursor 2 move simultaneously.

### Setting cursor 2

← Select f : V-C2 by pressing TCK/INDEP.

- The function display changes into f : V-C2.

← • Symbol “ ” appears to the left of V cursor 2 indicating that V cursor 2 is movable.

**Move V cursor 2 ( ---- ) to the other measurement point by turning [FUNCTION] .**

- The results of measurement of the voltage differences between the newly set cursors are displayed in the lower lefthand corner of the screen.
- When two or more channels of waveforms are displayed, select the channel to measure by pressing ATTACH.

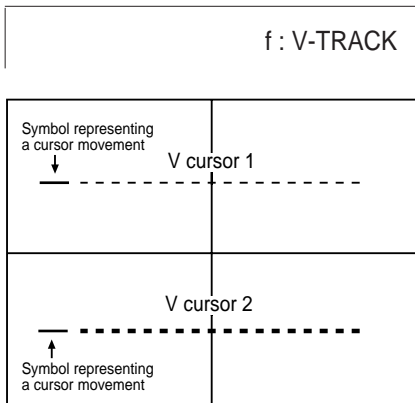

### Setting the tracking

- ← **Select TCK (tracking) by pressing TCK/INDEP .**
  - Function display changes into f:V-TRACK.
- ← • Symbol “ I ” appears to the left of V cursor 1 and V cursor 2 indicating that both cursors are movable.

**Turn FUNCTION , then V cursor 1 and V cursor 2 move together while maintaining the interval between them.**

### ◇ Release $\Delta V$ measurement

Select OFF (no cursor display) by pressing  $\Delta V$  .

## 3.3 Counter

Measure the frequency of the input signal on the counter.

### Operating method

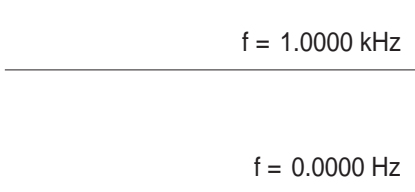

### Procedures

#### Take A triggering (refer to “2.9 Triggering”)

- ← • When A triggering is set, the result of measurement is constantly displayed in the lower righthand corner of the screen.
- The specified A trigger source is the object of measurement.
- The measurement range is 2 Hz to 400 MHz.
- ← • When A triggering is not set or the input signal exceeds the measurable frequency range, 0 Hz is displayed.

# Section 4. Save/Recall

Panel setup conditions can be saved and/or recalled.

## 4.1 Save

This is the function to save panel setup conditions.

### Operating method

### Procedures

**Set the panel setup conditions.**

### Setting the register number

**Set to the save mode by pressing SAVE/RECALL.**

- Function display changes into f:SAVE nn.
- nn: Register number**

f : SAVE nn ←

**Select the register number to be saved by turning FUNCTION.**

- The range of register numbers that can be saved \* 1 is 1 to 32.

Register No.  
↓  
f : SAVE 32 ←

### Input of a comment

**Press FUNCTION.**

- The comment-input screen is displayed.

[002: : ] Save f : SAVE 32 ←  
-----  
Comment display field

**Input the comment by pressing FUNCTION and turning FUNCTION.**

- Up to 12 characters can be input.
- Refer to the following page for the details of the method to input the comment.
- An example where comment "SS-7840" is input is shown.
- The comment is saved immediately when it has been input.

Example of input

↓  
[SS-7840 ] Save f : SAVE 32 ←

### Executing save

**Move the cursor to below S of Save by turning FUNCTION.**

**Press FUNCTION.**

- SAVED is displayed in the lower left corner of the screen.
- The setup conditions is saved in the register of which number is displayed and then the save mode is released.

[SS-7840 ] Save f : SAVE 32 ←  
                  ↑  
                  Cursor

SAVED.

**When saving multiple setup conditions, repeat procedures to .**

### ◇ Releasing the save mode

- The SAVE/RECALL key

The mode is switched as follows each time SAVE/RECALL is pressed.

SAVE RECALL OFF (release of the SAVE/RECALL mode) SAVE

However, because the release occurs once after entering the RECALL mode, the settings change into those that are newly recalled.

- Another function key

When another function key (Ex.: the HOLDOFF key) is pressed, it is possible to exit the SAVE mode without changing the settings.

### ◇ Register number \*1

When the unit is shipped from the factory, the maximum value is set to 32. The maximum value can be expanded to 256 using the system menu (refer to "Setting the maximum value of SAVE/RECALL" on page 44).

## Comment input method

### Operating method

[ \_ ] Save f : SAVE 32  
 ↑  
 Changes from \_ to : and vice versa each time the button is pressed.

[ \_ ] Save f : SAVE 32  
 ↑  
 Thick cursor (cursor moving mode)

[ \_ ] Save f : SAVE 32  
 ↑  
 Character input position

[ : ] Save f : SAVE 32  
 ↑  
 Thick cursor (character selection mode)

[ :S ] Save f : SAVE 32  
 ↑  
 Select characters

xxxxxxxx !  
 ↑  
 Input as the 12th character

[ S ] Save f : SAVE 32  
 ↑  
 Thick cursor (cursor moving mode)

### Procedures

← **The thickness of the cursor is switched each time [FUNCTION] is pressed.**

- Thick cursor display (cursor moving mode)  
The cursor moves to left or right as [FUNCTION] is turned.
- Thin cursor display (character selection mode)  
Characters can be selected as [FUNCTION] is turned.

← **Set the cursor-moving mode by pressing [FUNCTION] .**

← **Move the cursor to the character input position by turning [FUNCTION] .**

← **Set the character selection mode by pressing [FUNCTION] .**

← **Select characters by turning [FUNCTION] .**

- Characters can be selected among from numerals, capital letters, and 28 symbols.  
Space, ! " # \$ % & ' ( ) \* +, - . / : ; < = > ? @ [ ^ \_
- If "!" is input as the 12th character of the comment, the register number is skipped in the recall mode. To release the skip function, delete "!" .

← **Confirm the selected characters by pressing [FUNCTION] .**

- The cursor moving mode is set.

**Repeat procedures to .**

### Setting and releasing a skip

When a comment has been input, that comment is immediately saved, so there is no need to save the once input comment. After the comment is input, release the save mode by pressing [SAVE/RECALL] or another function key.

The comment alone can be changed without affecting the setup conditions that are saved.



## 4.2 Recall

### Operating method

f : RECALL nn

#### Procedures

← **Set the recall mode by pressing **SAVE/RECALL** twice.**

- Function display changes into f : RECALL nn.
- nn : The register No. from which the setup conditions are to be recalled.

**Select the register no. by turning **FUNCTION** .**

- The setup conditions are recalled from the register of the selected no.
- If "!" is written at the 12th character of the comment, that register number will be skipped. To release the skip, delete the "!" at the 12th character on the comment input screen.  
(Refer to "Comment Input Method" on page 43.)

◇ **Releasing the recall mode**

Press **SAVE/RECALL** .

### Setting the maximum value of SAVE/RECALL (SAVE/RECALL MAX)

The maximum value for the register number in the SAVE/RECALL mode can be expanded using the system menu.

#### Operating method

Not function display →



← **Set all functions to OFF and set the **FUNCTION** key to an invalid state \*1.**

\* 1 The state where no f:XXXXX is displayed on the upper right corner of the screen.

Function displayed → f : SYS-MENU

← **Select OFF (non-display) by pressing **READOUT** .**

← **Press **FUNCTION** for 3 sec, then the system menu is displayed.**

SAVE/RECALL MAX : 32  
+:[AUTO]-:[NORM] EXIT:[SGL/RST]

← **Select SAVE/RECALL MAX by turning **FUNCTION** .**

**Set the maximum value for the register number using **AUTO** and **NORM** .**

- The range for setting is 1 to 126.
- AUTO : Increases the register number.
- NORM : Decreases the register number.

◇ **Press **SGL/RST** to release the system menu.**

# Section 5. Daily Inspections

## a. Methods for servicing

### ◇ Cleaning

Wipe off the stains on the casing and cover with soft cloth dampened with a small volume of water or diluted neutral cleanser. If any solvent or cleanser not suitable for cleaning is used, it may cause discoloration or an unexpected fault.

- Solvent or cleanser that can be used : Water and neutral cleanser
- Solvent or cleanser that cannot be used : Alcohol, gasoline, acetone, lacquer, ether, thinner, and cleansers containing ketone

### ◇ Stains on the CRT

Remove stains in the following manner:

- Wipe off ordinary stains with a soft cloth.
- Wipe off stubborn stains with a cloth dampened with neutral cleanser.

## b. Cycles of periodical calibration

To ensure instrument accuracy calibrate once every year or, every 2000 hours in ordinary use.

Calibration cycle may be reduction if the instrument is heavy use or harsh environment.

## c. Automatic calibration

The following items are calibrated automatically:

- Changes in vertical position of traces after switching the voltage deflection factor.
- GND position.
- Vertical position.

### Cautions

- Perform calibration with BEAM FIND released.
- Automatic calibration is not accomplished correctly if BEAM FIND is pressed.
- Perform calibration with no signal input.
- Automatic calibration is not accomplished correctly if there are signals input to any INPUT (CH1, CH2, CH3, CH4).

### Operating method

### Procedures

|  |  |
|--|--|
| Not function display → <span style="border: 1px dashed black; display: inline-block; width: 40px; height: 15px;"></span> | ← <b>Set all functions to OFF and set the 【FUNCTION】 key to an invalid state *1.</b><br>* 1 The state where no f:XXXXX is displayed on the upper right corner of the screen.   |
| Function displayed → f : SYS-MENU  | ← <b>Select OFF (non-display) by pressing 【READOUT】 .</b><br><b>Press 【FUNCTION】 for 3 sec, then the system menu is displayed.</b>   |
| CALIBRATE<br>GO:[NORM] EXITP:[SGL/RST]   | ← <b>Select CALIBRATE by turning 【FUNCTION】 .</b><br>• The message on the left is displayed at the center of the screen.<br>• Press <span style="border: 1px solid black; padding: 0 2px;">SGL/RST</span> to release the system menu.                |
| COMPLETE   | ← <b>Press <span style="border: 1px solid black; padding: 0 2px;">NORM</span> , then automatic calibration starts.</b><br>• In the case of normal completion, the message on the left is displayed momentarily and exit from the system menu occurs. |

◇ If automatic calibration does not complete normally, an error message is displayed. When an error message is displayed after executing automatic calibration several times while it is confirmed that there is no input of signals, contact one of our service stations.

#### d. Calibration of the character center

Character positions can be calibrated if they have deviated due to the influence of earth magnetism.

##### Operating method

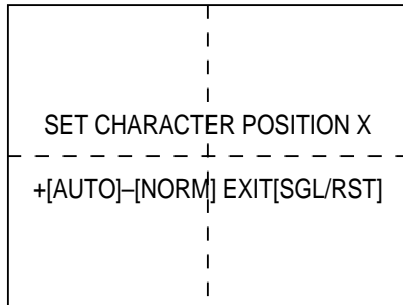

##### Procedures

to Same as those for “c. Automatic calibration”.

##### Adjustment of the horizontal position

← Select SET CHARACTER POSITION X by turning [FUNCTION] .

Adjust the character position to the center in the horizontal direction using [AUTO] and [NORM] .

- To release the system menu, press [SGL/RST] .

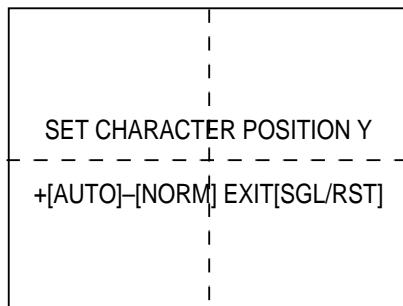

##### Adjustment of the vertical position

← Select SET CHARACTER POSITION Y by turning [FUNCTION] .

Adjust the character position to the center in the vertical direction using [AUTO] and [NORM] .

- To release the system menu, press [SGL/RST] .

#### e. Guide to diagnosing

When this instrument does not operate or seems to be experiencing some abnormality, confirm the contents shown in Table 5.1.1.

#### f. Storage and transportation

##### ◇ Storage

Avoid storage in the following places:

- In locations exposed to direct sunlight
- In locations where there is a large amount of dust
- In locations exposed to corrosive gas

The conditions for storage of this instrument are as follows:

Storage temperature : - 20 to +70 °C

Storage humidity : 80 %RH or less (at 70 °C)

##### ◇ Transportation

When transporting this instrument, use packaging materials equal or superior to those used when this instrument was purchased.

Table 5.1.1 Guide to Diagnosing Faults

| Phenomenon  | Confirmation items  | Remedy   |
|---|---|--|
| Traces or luminescent spots do not appear.                        | Check that the power cord plug is connected to the AC receptacle. | Connect the plug to the AC receptacle.                             |
|   | Check that the power switch is set to ON.                         | Set the power switch to ON.  |
|   | Check that INTEN is turned counterclockwise.                      | Turn INTEN clockwise until an adequate intensity is obtained.      |
|   | Check that SWEEP MODE is set to SINGLE.                           | Set SWEEP MODE to AUTO.  |
| Scales on the screen are not clearly displayed.                   | Check that SCALE is turned counterclockwise.                      | Turn INTEN clockwise until an adequate intensity is obtained.      |
|   | Check that the illumination lamp is disconnected.                 | Contact your nearest Iwatsu sales agent.                           |
| Characters are not displayed.                                     | Check that READOUT is turned counterclockwise.                    | Turn INTEN clockwise until an adequate intensity is obtained.      |
| Focus of traces and characters is not clear.                      | Check whether the adjustment of FOCUS is deviated.                | Adjust FOCUS so that it becomes clear.                             |
| Waveform does not appear when signals are input.                  | Check that the probe is disconnected.                             | Replace the probe.   |
|   | Check that the input coupling is set to GND.                      | Release GND.   |
|   | Check whether a wrong channel is selected.                        | Set the channel to which input signals are connected to ON.        |
|   | Check whether the voltage sensitivity is too low.                 | Increase the sensitivity.  |
| Triggering cannot be set.   |   | Press AUTO SET.  |
|   | Check whether the wrong trigger source is selected.               | Select the channel to which trigger are input.                     |
|   | Check whether the wrong trigger coupling mode is selected.        | Set the trigger coupling mode suitable for input signals again.    |
| Waveform is unstable.   | Check whether the level is set to an inadequate position.         | Adjust the level to the position where triggering is set.          |
|   | Check whether the AC supply voltage is too low.                   | Use an AC power supply within the rating.                          |
| Original settings are not restored when power is turned on again. |   | Replace the battery by contacting your nearest Iwatsu sales agent. |

## Section 6. Specifications

### CRT

Display type 6 inch, diagonal rectangular flat face, internal graticule, meshless CRT with graticule illumination

Display area 8 div x 10 div (1 div= 10 mm)

Acceleration voltage Approx. 20 kV

### Vertical deflection system (Y axis)

Vertical mode CH1, CH2, CH3, CH4, ADD (CH1+CH2), ALT/CHOP

CH1, CH2 CHOP mode switching rate 555 kHz ± 1 %.

Deflection factor

Range 2 mV/div to 5 V/div, 1-2-5 sequence, 11 steps

Variable control range 2 mV/div to 12.5 V/div continuously variable

Accuracy ± 2%

Frequency characteristics

Bandwidth DC to 400 MHz – 3 dB

Bandwidth limiter DC to approx. 20 MHz or DC to approx. 100 MHz can be selected

Rise time Approx. 875 ps

[Note] Rise time Tr is the calculated value from the following expression, and is no guarantee value.

$$Tr[s] = \frac{0.35}{\text{Bandwidth [Hz]}}$$

Step response at 10 mV/div, with internal 50 Ω termination

Overshoot 5 %

Sag (at 1 kHz) 1 %

Signal delay At least 20 ns of the sweep is displayed before the triggering event.

Input coupling AC, DC, GND



Input RC 1 MΩ ± 1.5 % // 16 pF ± 2 pF, 50 Ω ± 1 %

Maximum input voltage ± 400 V (DC+ACpeak)

1 MΩ

50 Ω

VSWR 1.35 MAX (50 Ω : DC to 400 MHz)

Offset voltage

| Vertical deflection range | Offset voltage |
|---------------------------|----------------|
| 2 mV/div to 50 mV/div     | ± 1 V          |
| 0.1 V/div to 0.5 V/div    | ± 10 V         |
| 1 V/div to 5 V/div        | ± 100 V        |

Position control range Approx. ± 10 div from the center line of the screen

Invert Available on CH2

ADD ± 3 %

Accuracy of sum (at 1 kHz)

Frequency characteristics DC to 400 MHz – 3 dB

Common-mode rejection ratio at 10 mV/div

1 kHz sine wave 50 : 1

20 MHz sine wave 15 : 1

Dynamic range 8 div or more 400 MHz input signal at 10 mV/div full bandwidth

Probe sense 10 : 1, 100 : 1 detection

CH3, CH4

Deflection factor

Range

Accuracy

Bandwidth

100 mV/div, 500 mV/div

± 3 %

DC to 400 MHz – 3dB

[Note] AC coupled low cutoff frequency (– 3 dB) is 10 Hz

1 MΩ ± 1.5 % // 16 pF ± 3 pF



Input RC

Maximum input voltage

Position control range

Dynamic range

Probe sense

± 400 V (DC+ACpeak)

Approx. ± 10 div from the center line of the screen

8 div or more 400 MHz input signal full bandwidth

10:1, 100:1 detection

### Triggering

A triggering

Trigger sensitivity

| Frequency         | P. P signal amplitude |
|-------------------|-----------------------|
| DC to 10 MHz      | 0.4 div               |
| 10 MHz to 100 MHz | 1.0 div               |
| 10 MHz to 400 MHz | 2.0 div               |

[Note] TV : The ratio between the composite video signal and synchronization signal is 7:3 and synchronization signal amplitude is 1.5 div or more.

HF-REJ : Attenuates at 10 kHz or more

LF-REJ : Attenuates at 10 kHz or less

Signal source

Coupling

Slope

CH1, CH2, CH3, CH4, LINE

AC, DC, HF-REJ, LF-REJ

+, –

B triggering

Trigger sensitivity

| Frequency         | P. P signal amplitude |
|-------------------|-----------------------|
| DC to 10 MHz      | 0.4 div               |
| 10 MHz to 100 MHz | 1.0 div               |
| 10 MHz to 250 MHz | 2.0 div               |

[Note] HF-REJ : Attenuates at 10 kHz or more

LF-REJ : Attenuates at 10 kHz or less

Signal source

Coupling

Slope

CH1, CH2, CH3, CH4

AC, DC, HF-REJ, LF-REJ

+, –

TV triggering

Mode

Formats

Field and line selection

NTSC

PAL (SECAM)

HDTV

ODD, EVEN, BOTH, TR-H

NTSC, PAL (SECAM), HDTV

ODD, EVEN, or BOTH can be selected

1 H to 525 H

1 H to 625 H

1 H to 1125 H

TV clamp

Clamp position

Back porch reference

Signal amplitude range

Back porch level

± 1 div or less from ground reference

1.5 to 8 div

|  |   |
|--|---|
| Event trigger                                |   |
| Count mode                                   |   |
| Event count range                            | 1 to 65535  |
| Maximum frequency                            | 50 MHz  |
| Burst mode                                   |   |
| Burst signal interval time                   | 0.15 $\mu$ s to 9.99 s  |
| AUTO SETUP                                   |   |
| Channels                                     | Available CH1 and CH2   |
| Frequency                                    | 50 Hz to 100 MHz  |
| <b>Horizontal deflection system (X axis)</b> |   |
| Horiz display                                | A, ALT, B, X-Y  |
| A sweep                                      |   |
| Sweep mode                                   | AUTO, NORMAL, SINGLE  |
| Sweep rates                                  |   |
| Maximum sweep                                | 500 ps/div  |
| Range  | 5 ns to 500 ms/div 1-2-5 sequence, 25 steps   |
| Variable range                               | 5 ns to 1.5 s/div   |
| Accuracy I                                   | $\pm 2\%$ <sup>1</sup> over center 8 div  |
| Accuracy II                                  | $\pm 5\%$ <sup>1</sup> over any 2 div within center 8 div   |
|  | <sup>1</sup> Add 1 % in case of VARIABLE ON   |
| Hold-off time                                | Continuously variable   |
| B sweep                                      |   |
| Delay  | Triggered delay or continuous delay (RUNS AFTER)  |
| Sweep rates                                  |   |
| Maximum sweep                                | 500 ps/div  |
| Range  | 5 ns to 20 ms/div 1-2-5 sequence, 21 steps  |
| Accuracy I                                   | $\pm 2\%$ over center 8 div   |
| Accuracy II                                  | $\pm 5\%$ over any 2 div within center 8 div  |
| Delay time                                   |   |
| Position control range                       | 0.2 to 10.2 div   |
| Accuracy                                     | $\pm [(set\ value\ \times\ 0.005) + (sweep\ rate\ \times\ 0.1)] - 55ns$ within the range of 1 $\mu$ s/div to 500 ms/div |
| Delay pick off jitter                        | 1/2000, at 1 ms/div of A sweep:, at 500 ns/div of B sweep   |
| Sweep magnification                          |   |
| Magnifying ratio                             | 10 times  |
| Accuracy I <sup>2</sup>                      | over center 8 div   |
| 10 ns/div, 50 ns/div                         | $\pm 5\%$   |
| 100 ns/div to 500 ms/div                     | $\pm 3\%$   |
| Accuracy II <sup>1 2</sup>                   | over any 2 div within center 8 div  |
| 5 ns/div, 50 ns/div                          | $\pm 10\%$  |
| 100 ns/div to 500 ms/div                     | $\pm 5\%$   |
|  | <sup>1</sup> 20 ns or 1 div at the beginning of sweep and 20 ns at the end of sweep are excluded.                       |
|  | <sup>2</sup> Add 1 % in case of VARIABLE ON   |
| <b>X-Y operation</b>                         |   |
| X axis (CH1)                                 |   |
| Deflection factor                            | Same as CH1.  |
| Accuracy                                     | $\pm 2\%$   |
| Bandwidth                                    | DC to 2 MHz, - 3 dB   |
| Y axis                                       | CH1, CH2, CH3, CH4, ADD   |
| Phase difference                             | 3° or less (DC to 200 kHz)  |

**CAL (Probe calibration signal)**

|                |                   |
|----------------|-------------------|
| Waveform       | Rectangular wave  |
| Frequency      | 1 kHz $\pm$ 0.1 % |
| Duty ratio     | 49 to 51 %        |
| Output voltage | 0.6 V $\pm$ 1 %   |

**CH2 OUT**

|                      |  |
|----------------------|--|
| Output voltage       | 20 mV/div $\pm$ 30 % (into 50 $\Omega$ ) |
| Output offset        | $\pm$ 100 mV (50 $\Omega$ )              |
| Output coupling      | DC coupling                              |
| Frequency band width | 200 MHz – 3dB (into 50 $\Omega$ )        |
| Output resistance    | 50 $\Omega$ $\pm$ 20 %                   |

**Z AXIS IN**

|                       |   |
|-----------------------|---|
| Sensitivity           | 0.5 Vp-p or more<br>Positive-going input decreases intensity. |
| Frequency range       | DC to 5 MHz   |
| Input resistance      | 5 k $\Omega$ $\pm$ 20 %                                       |
| Maximum input voltage | $\pm$ 40 V (DC+ACpeak)  |

**Measurement with cursors and counter**

|                                   |   |
|-----------------------------------|---|
| Measurement with cursors          |   |
| Type of measurement               | Time difference ( $\Delta t$ ), voltage difference ( $\Delta V$ ) |
| Cursor position control range     |   |
| X axis                            | $\pm$ (5 $\pm$ 0.2) div from the center line of the screen        |
| Y axis                            | $\pm$ (4 $\pm$ 0.2) div from the center line of the screen        |
| Accuracy                          |   |
| Voltage difference ( $\Delta V$ ) | $\pm$ [(2 % of reading) + (0.3 % of full scale)]                  |
| Time difference ( $\Delta t$ )    |   |
| MAG OFF                           | $\pm$ [(2 % of reading) + (0.3 % of full scale)]                  |
| MAG ON (MAG x 10)                 |   |
| 500 ms to 100 ns/div              | $\pm$ [(3 % of reading) + (0.3 % of full scale)]                  |
| 50 ns, 5 ns/div                   | $\pm$ [(5 % of reading) + (0.3 % of full scale)]                  |

|                             |                 |
|-----------------------------|-----------------|
| Counter                     |                 |
| Number of digits displayed  | 5 digits        |
| Accuracy                    | $\pm$ 0.01%     |
| Frequency measurement range | 2 Hz to 400 MHz |

**Saving data**

|                          |  |
|--------------------------|--|
| Type of data to be saved | Backup by built-in battery<br>Panel setup conditions immediately before turning power off* <sup>1</sup><br>Storing of panel setup conditions |
| Data retention time      | * <sup>1</sup> The state where the power cord is disconnected.<br>Approx. 30,000 H (at approx. 25°C)   |

**Power source**

|                   |                |
|-------------------|----------------|
| Voltage range     | 100 to 240 VAC |
| Frequency range   | 50/60 Hz       |
| Power consumption | 130 VA         |

**Mass and Dimension**

|           |  |
|-----------|--|
| Mass      | Approx. 8.5 kg (without accessories)   |
| Dimension | Approx. 320 x 160 H x 406 L [mm]<br>[Note] Without accessories, and projections. |



## Environmental conditions

|                                     |   |
|-------------------------------------|---|
| Specification assurance temperature | 10 to 35°C  |
| Operating                           |   |
| Temperature                         | 0 to 40°C   |
| Humidity                            | 90 % RH or less (at 40°C)   |
| Storage                             |   |
| Temperature                         | – 20 to 70 °C   |
| Humidity                            | 80 % RH or less (at 70°C)   |
| Altitude                            |   |
| Operating                           | 2,000 m, atmospheric pressure : Approx. 79 kPa  |
| Nonoperating                        | 15,000 m, atmospheric pressure : Approx. 12 kPa   |
| Vibration                           | 15 minutes along each of three axes at a total displacement of 0.67 mm p.p with frequency varied from 10 Hz to 55 Hz in 1 minute sweep.                           |
| Shock                               | Lifting a side to height of 10 cm and dropping it naturally onto hard wood; 4 times on each side.   |
| Dropping packaged                   | Dropping an instrument packaged for transportation from a height of 90 cm.  |
| Warm up time                        | The specifications for this instrument are the assured values after more than 30 min of power on.   |
| CE Declaration of Conformity        | The Oscilloscope meets requirements of the Council Directive 89/336/EEC for Electromagnetic Compatibility and Low Voltage Directive 73/23/ECC for Product Safety. |
| Electromagnetic Emission            |   |
| EN55011:1991                        |   |
| EN55011:1991                        | Class B Radiated and Conducted Emissions  |
| EN61000-3-2:1995                    | AC Power Line Harmonic Current Emissions  |
| EN61000-3-3:1995                    | Voltage Fluctuations and Flicker  |
| Electromagnetic Susceptibility      |   |
| EN50082-2:1995                      |   |
| EN61000-4-2:1995                    | Electrostatic Discharge Immunity  |
| ENV50140:1993                       | RF Field Strength Susceptibility (Amplitude Modulation)   |
| ENV50204:1995                       | RF Field Strength Susceptibility (Pulse Modulation)   |
| EN61000-4-4:1995                    | Electrical Fast Transient/Burst Immunity  |
| ENV50141:1993                       | Conducted Susceptibility  |
| Low Voltage Directive               |   |
| EN61010-1:2001                      | Safety requirement for electrical equipment for measurement, control, and laboratory use.   |

The oscilloscope has been qualified to the following EN61010-1 category:

|  |  |
|--|--|
| Installation (Overvoltage) Category II | Pollution Degree 2   |
| Pollution Degree 2                     | Do not operate in environments where conductive pollutants may be present. |
| Installation (Overvoltage) Category II | Local Level mains, appliances, portable equipment.                         |

## Probe SS-101R

The SS-101R is a high impedance passive probe with a wide range of probing accessories. It is designed to give high impedance probing capability to a circuit when attached to a Oscilloscope.

|                                    |   |
|------------------------------------|---|
| System BW (−3dB)                   | : 500 MHz                                   |
| System Attenuation                 | : $10\times\pm 2\%$                         |
| System Input Resistance            | : $10\text{ M}(\Omega) // 12\text{ pF}$     |
| Compensation Range                 | : 13 pF to 23 pF                            |
| Cable Length                       | : 1.2 meters, Connector type BNC            |
| Max. non-destructive input voltage | : 600 V (DC + Peak AC) (see derating curve) |
| Probe Sense                        | : Yes                                       |

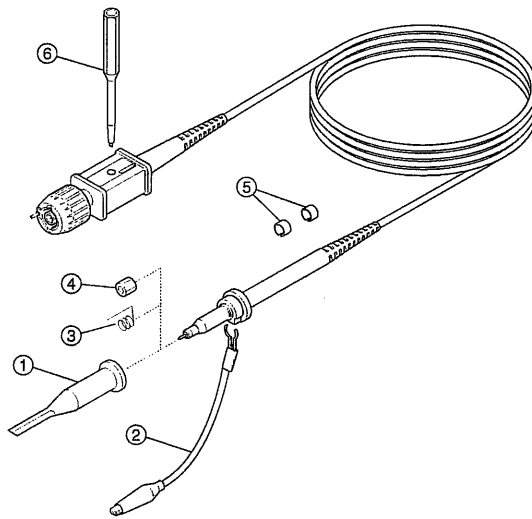

### Accessories Table

| Item                                 | Quantity |
|--------------------------------------|----------|
| ① Sprung hook                        | 1        |
| ② Ground lead (11 cm)                | 1        |
| ③ Ground lead on probe tip           | 1        |
| ④ IC Insulating tip                  | 1        |
| ⑤ Color marking band (orange, white) | 2×2      |
| ⑥ Trimmer tool                       | 1        |

## Probe Adjustment

### LF Adjustment

LF compensation is made by connecting the probe to the cal signal and adjusting the compensation trimmer in the BNC-box at end of the probe. Connect the BNC end of the SS-101R to a channel of the oscilloscope. Connect the sprung hook end (1) and the ground lead (2) to the CAL out and GND on the scope Calibrator area. The CAL signal is available in many speeds. Select the Utilities in the scope to set the CAL to 1 kHz. Turn the scope channel on. Press Auto Setup and adjust the time base and volts/div settings until the signal on the screen contains two cycles (see figures below). Use the Trimmer tool (6) to adjust the probe response to match the correct trim shown below.

[Note] Do not apply excess pressure to the screwdriver when you use it. The tip of screwdriver are is easy to brake, because of made by plastics.

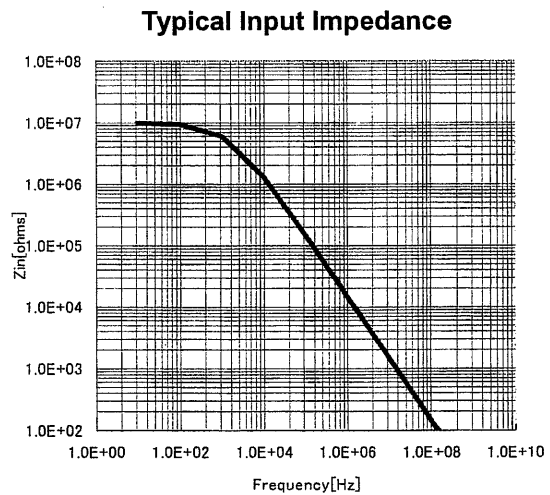
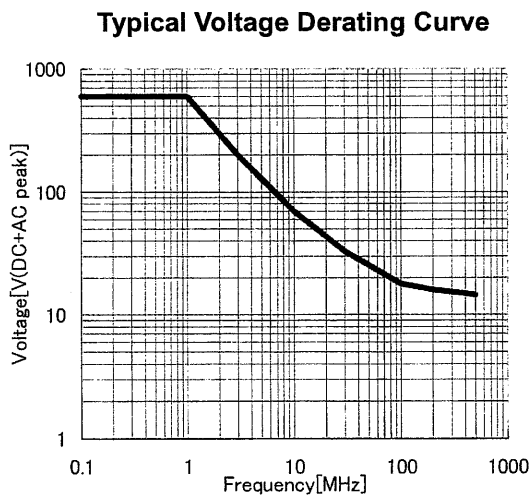
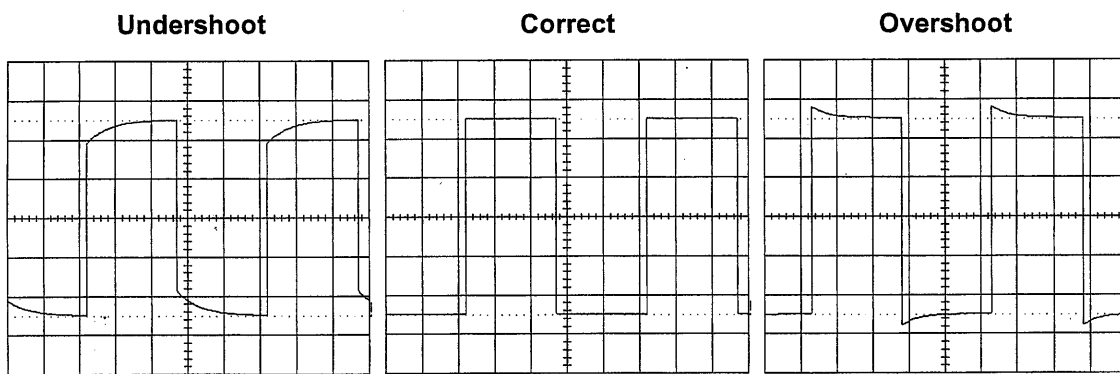

## Installation for Safe and Efficient Operation

### Operating Environment



Before using the Probe, ensure that its operating environment will be maintained within these parameters :

- Operation : In-door Use
- Temperature : 0 to 40 °C (performance security temperature is 10 to 35 °C)
- Humidity : 40 °C < 90 % RH (non-condensing)

The Probe has been designed to comply with EN61010-1 Installation (Overvoltage) Category II, 600 V, Pollution Degree 2.

### Safety Symbols

Wherever the following safety symbols appear on the Probe or in the instruction manual, they alert the user to an aspect of safety.

| Symbol  | Meaning   |
|---|---|
|  | Refer to accompanying documents (for Safety-related information).                                       |
|  | Risk of electric shock.   |
| CAUTION   | Calls attention to a procedure, practice or condition that could possibly cause damage to equipment.    |
| WARNING   | Calls attention to a procedure, practice or condition that could possibly cause bodily injury or death. |

### Usage

The probe is intended to be used only with instruments which are connected to earth ground through the input BNC connector. Connect the grounding terminal of the probe to the ground potential of a device to be measured.



**WARNING** Do not disconnect the probe while it is connected to a voltage source.  
Do not directly touch a measuring point. Do not use the probe in wet or explosive atmospheres.



**WARNING** Probe tips are sharp, misuse can result in injury. Use with care.  
The use of the probe and/or the instrument it is connected to in a manner other than specified may impair the safety mechanisms.



**CAUTION** To guarantee accurate performance characteristics, mechanical shocks should be avoided, as well as damage to the cable through excessive bending. Do not exceed the maximum specified signal voltage levels (See Specifications).

## **Cleaning and Maintenance**

The exterior of the probe and cable should only be cleaned using a soft cloth moistened with water or isopropyl alcohol. The use of abrasive agents, strong detergents, or other solvents may damage the probe. Assure that the input receptacles are free of debris before inserting connection accessories.

All repair and maintenance should be referred to qualified service personnel. Do not use the probe if any part is damaged.

# INDEX

## [A]

|                                |        |
|--------------------------------|--------|
| A (Sweep) .....                | 22, 23 |
| A (Trigger) .....              | 22     |
| A INTEN .....                  | 13     |
| AC (Input coupling) .....      | 16     |
| AC (Trigger coupling) .....    | 26     |
| AC LINE INPUT .....            | 7      |
| Accessories .....              | IX     |
| Active probe .....             | 20     |
| ADD (Addition) .....           | 19     |
| Adjustment of the screen ..... | 13     |
| ATL (alternate) .....          | 18, 32 |
| AUTO (Sweep mode) .....        | 25     |
| Automatic calibration .....    | 45     |
| AUTOSET .....                  | 10, 11 |

## [B]

|                               |        |
|-------------------------------|--------|
| B (Sweep) .....               | 22, 23 |
| B (Trigger) .....             | 22     |
| B ENDS A .....                | 35, 36 |
| B INTEN .....                 | 13     |
| Back porch level .....        | 29     |
| Bandwidth limiter (BWL) ..... | 19     |
| Basic Operation .....         | 8      |
| BEAM FIND .....               | 13     |
| BOTH (TV trigger mode) .....  | 28     |
| Brightness (INTEN) .....      | 13     |
| Built-in battery .....        | 8      |
| BURST (Event) .....           | 30, 31 |

## [C]

|                             |    |
|-----------------------------|----|
| CAI .....                   | 10 |
| Cautions for safe use ..... | 1  |

|  |        |
|--|--------|
| CH2 DLY .....                          | 24     |
| CH2 OUT PUT .....                      | 7      |
| CHOP .....                             | 18     |
| Clamp .....                            | 29     |
| Cleaning .....                         | 45     |
| Components .....                       | IX     |
| Continuous delay .....                 | 34     |
| COUNT (Event) .....                    | 30, 31 |
| Counter .....                          | 41     |
| COUPL (Trigger coupling) .....         | 26     |
| Cursor Measurement .....               | 38     |
| Cycles of periodical calibration ..... | 45     |

## [D]

|                             |    |
|-----------------------------|----|
| Daily Inspections .....     | 45 |
| DC (Input coupling) .....   | 16 |
| DC (Trigger coupling) ..... | 26 |
| Deflection Factor .....     | 15 |
| Delay Adjust .....          | 24 |
| Delayed sweep .....         | 34 |
| Difference (CH1-CH2) .....  | 19 |
| Display channels .....      | 18 |
| Displayed characters .....  | 13 |

## [E]

|                              |        |
|------------------------------|--------|
| EVEN (TV trigger mode) ..... | 28     |
| Event .....                  | 30, 31 |
| Event Trigger .....          | 30     |
| Explanations of terms .....  | X      |

## [F]

|                 |    |
|-----------------|----|
| FET probe ..... | 20 |
| FOCUS .....     | 13 |

|                        |    |
|------------------------|----|
| FORMATS .....          | 29 |
| Frequency (1/Δt) ..... | 38 |
| FUSE .....             | 7  |

## [G]

|                                  |    |
|----------------------------------|----|
| GND (Input coupling) .....       | 16 |
| Grounding .....                  | 8  |
| Guide to Diagnosing Faults ..... | 46 |

## [H]

|                              |    |
|------------------------------|----|
| HDTV .....                   | 29 |
| HF REJ .....                 | 26 |
| Holdoff .....                | 37 |
| Horizontal Display .....     | 32 |
| How to read the screen ..... | 9  |

## [I]

|                           |    |
|---------------------------|----|
| Input coupling .....      | 16 |
| Input resistance .....    | 17 |
| Intensity of scales ..... | 13 |
| INV .....                 | 19 |

## [L]

|                               |    |
|-------------------------------|----|
| LEVEL .....                   | 27 |
| LF REJ .....                  | 26 |
| LINE (Trigger coupling) ..... | 26 |
| LINE (TV) .....               | 28 |

## [M]

|   |    |
|---|----|
| MAG x 10 .....                                      | 23 |
| Magnification .....                                 | 23 |
| Methods for servicing .....                         | 45 |
| Move the position in the horizontal direction ..... | 14 |
| Move the position in the vertical direction .....   | 14 |

## [N]

|                         |        |
|-------------------------|--------|
| NORM (Sweep mode) ..... | 25     |
| NTSC .....              | 28, 29 |
| number of lines .....   | 28, 29 |

## [O]

|                             |    |
|-----------------------------|----|
| ODD (TV trigger mode) ..... | 28 |
| Offset .....                | 20 |

## [P]

|                           |      |
|---------------------------|------|
| P1, P2 .....              | 21   |
| PAL .....                 | 29   |
| POSITION .....            | 14   |
| Power OFF .....           | 8    |
| Power ON .....            | 2    |
| Power Source (Line) ..... | 26   |
| Power STBY .....          | 2, 8 |
| Probe Compensation .....  | 12   |
| PROBE POWER .....         | 4    |
| Probe sense .....         | 12   |

## [R]

|   |    |
|---|----|
| READOUT .....                                 | 13 |
| READY .....                                   | 5  |
| Recall .....                                  | 44 |
| Releasing the loading effect by a probe ..... | 12 |
| Repetitive sweep (AUTO, NORM) .....           | 25 |
| RST (RESET) .....                             | 25 |

## [S]

|              |    |
|--------------|----|
| Save .....   | 42 |
| SCALE .....  | 13 |
| SECAM .....  | 29 |
| Single ..... | 25 |

|   |            |
|---|------------|
| Single sweep .....                      | 25         |
| Slope .....                             | 27         |
| Source .....                            | 26         |
| Specification .....                     | 48         |
| Stain on the CRT .....                  | 45         |
| Storage .....                           | 47         |
| Subtract (CH1-CH2) .....                | 19         |
| Sum (CH1+CH2) .....                     | 19         |
| Sweep mode .....                        | 25         |
| Sweep Rate (TIME/DIV) .....             | 23         |
| Symbols in the instruction manual ..... | 1          |
| Symbols on the panel .....              | 1          |
| SYS-MENU .....                          | 21, 44, 45 |
| System menu .....                       | 21, 44, 45 |

## [T]

|                                      |        |
|--------------------------------------|--------|
| TCK .....                            | 39, 41 |
| Time Difference ( $\Delta t$ ) ..... | 38     |
| TIME/DIV .....                       | 23     |
| TRACE ROTATION .....                 | 13     |
| Trace separation .....               | 33     |
| Trace Separation .....               | 33     |
| tracking .....                       | 39, 41 |
| transportation .....                 | 47     |
| Trigger Coupling .....               | 26     |
| Trigger Level .....                  | 27     |
| Trigger Slope .....                  | 27     |
| Trigger Source .....                 | 26     |
| Triggered Delay .....                | 36     |
| Triggering .....                     | 26     |
| TRIG'D .....                         | 5      |
| TV CLAMP .....                       | 29     |
| TV signal .....                      | 28     |
| TV trigger mode .....                | 28, 29 |

|            |    |
|------------|----|
| TV-H ..... | 28 |
|------------|----|

## [V]

|   |    |
|---|----|
| Vertical Deflection System .....        | 15 |
| Voltage Difference ( $\Delta V$ ) ..... | 40 |
| Voltage standing wave ratio (VSWR) .    | 17 |
| VOLTS/DIV .....                         | 15 |
| VSWR .....                              | 17 |

## [X]

|           |    |
|-----------|----|
| X-Y ..... | 32 |
|-----------|----|

## [Z]

|                |   |
|----------------|---|
| ZAXIS IN ..... | 7 |
|----------------|---|



## Numerals and Symbols

|                                      |    |
|--------------------------------------|----|
| 1M $\Omega$ (Input resistance) ..... | 17 |
| 50 $\Omega$ (Input resistance) ..... | 17 |
| 1/ $\Delta t$ .....                  | 38 |
| $\Delta t$ .....                     | 38 |
| $\Delta V$ .....                     | 40 |

## Knobs, Keys, etc.

|                                |               |
|--------------------------------|---------------|
| <b>A</b> key .....             | 5, 32 to 34   |
| <b>AB</b> key .....            | 5, 22, 26, 27 |
| AC LINE INPUT terminal .....   | 7             |
| <b>ADD CH1+CH2</b> key .....   | 3, 19         |
| <b>[A INTEN]</b> knob .....    | 2, 13         |
| <b>ALT CHOP</b> key .....      | 4, 18         |
| <b>ATTACH</b> key .....        | 6, 20, 21, 40 |
| <b>AUTO</b> key .....          | 6, 25         |
| <b>AUTOSET</b> key .....       | 6, 10         |
| <b>[A VARIABLE]</b> knob ..... | 4             |
| <b>B</b> key .....             | 5, 32 to 34   |
| <b>[B INTEN]</b> knob .....    | 2, 13         |
| <b>[BEAM FIND]</b> knob .....  | 2, 13         |
| <b>BWL</b> key .....           | 4, 19         |
| CAL (OUT) .....                | 4, 10         |
| <b>CH1</b> key .....           | 3, 18         |
| <b>CH2</b> key .....           | 3, 18         |
| CH2 OUTPUT TERMINAL .....      | 7             |
| <b>CH3</b> key .....           | 3, 18         |
| <b>CH4</b> key .....           | 3, 18         |
| <b>COUPL</b> key .....         | 5, 26         |
| <b>DC/AC</b> key .....         | 3, 16         |
| <b>DELAY/TRACE SEP</b> key ..  | 15, 33, 36    |
| <b>FINE</b> key .....          | 4, 14         |
| <b>[FOCUS]</b> knob .....      | 2, 13         |
| <b>[FUNCTION]</b> knob .....   | 6             |
| FUSE .....                     | 7             |
| <b>EVENT/TV CLAMP</b> key ...  | 5, 29, 30     |
| <b>GND</b> key .....           | 3, 13, 16     |

|  |           |
|--|-----------|
| <b>HOLDOFF</b> key .....                                     | 5, 37     |
| INPUT (CH1 to CH4) connectors ...                            | 3         |
| <b>INV</b> key .....   | 3, 19     |
| <b>MAG x10</b> key .....                                     | 4, 23     |
| <b>NORM</b> key .....  | 6, 25     |
| <b>OFFSET</b> key .....                                      | 6, 20, 21 |
| <b>[▲POSITION▼]</b> knob .....                               | 3, 14     |
| <b>[◀POSITION▶]</b> knob .....                               | 3, 14     |
| <b>POWER</b> key .....                                       | 2, 10     |
| PROBE POWER P1/P2 terminal ...                               | 4         |
| <b>[READOUT]</b> knob .....                                  | 2, 13     |
| READY indicator .....  | 5         |
| <b>SAVE/RECALL</b> key .....                                 | 6, 42, 44 |
| <b>[SCALE</b> knob .....                                     | 2, 13     |
| <b>SGL/RST</b> key .....                                     | 6, 25     |
| <b>SLOPE</b> key .....                                       | 5, 27     |
| <b>SOURCE</b> key .....                                      | 5, 26     |
| <b>TCK/INDEP</b> key .....                                   | 6, 38, 41 |
| <b>[TIME/DIV]</b> knob .....                                 | 4, 23     |
| TRACE ROTATION volume .....                                  | 2, 13     |
| TRIG'D indicator .....                                       | 5         |
| <b>[TRIG LEVEL]</b> knob .....                               | 5, 12, 27 |
| <b>TV</b> key .....  | 5, 28, 29 |
| <b>[VOLTS/DIV]</b> knob .....                                | 3, 15     |
| <b>X-Y</b> key .....   | 5, 32     |
| Z AXIS IN .....  | 7         |
| <b>100mV/500mV</b> key .....                                 | 3, 15     |
| <b>50<math>\Omega</math>/1M<math>\Omega</math></b> key ..... | 3, 17     |
| <b><math>\Delta t</math></b> key .....                       | 6, 38     |
| <b><math>\Delta V</math></b> key .....                       | 6, 40     |

Memo

---

**IWATSU TEST INSTRUMENTS CORPORATION**

**Address** : 7-41 Kugayama 1-chome Suginami-ku, Tokyo, 168-8511 Japan

**Phone** : +81 3 5370 5483

**Facsimile** : +81 3 5370 5492

**Homepage** : <http://www.itl.iwatsu.co.jp>