

Operating Instructions

Waterpilot FMX21

Hydrostatic level measurement
HART

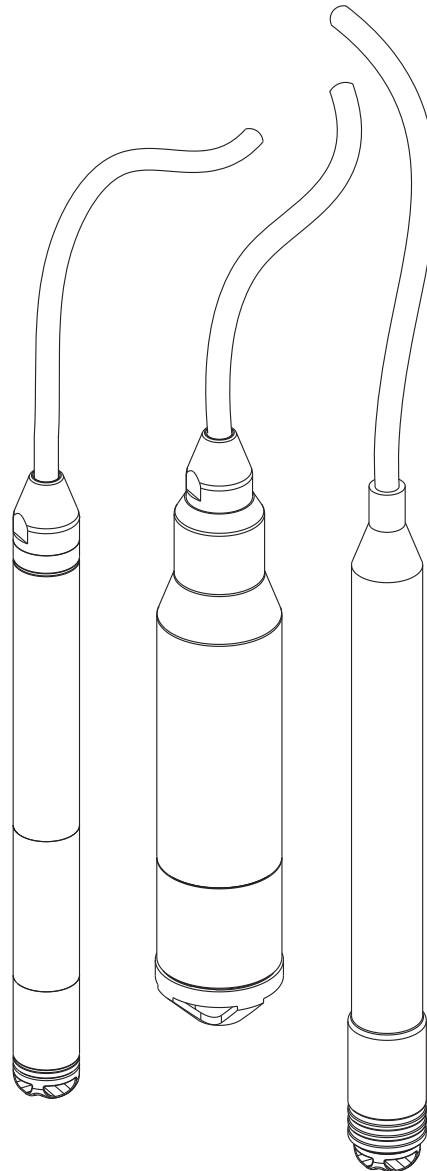

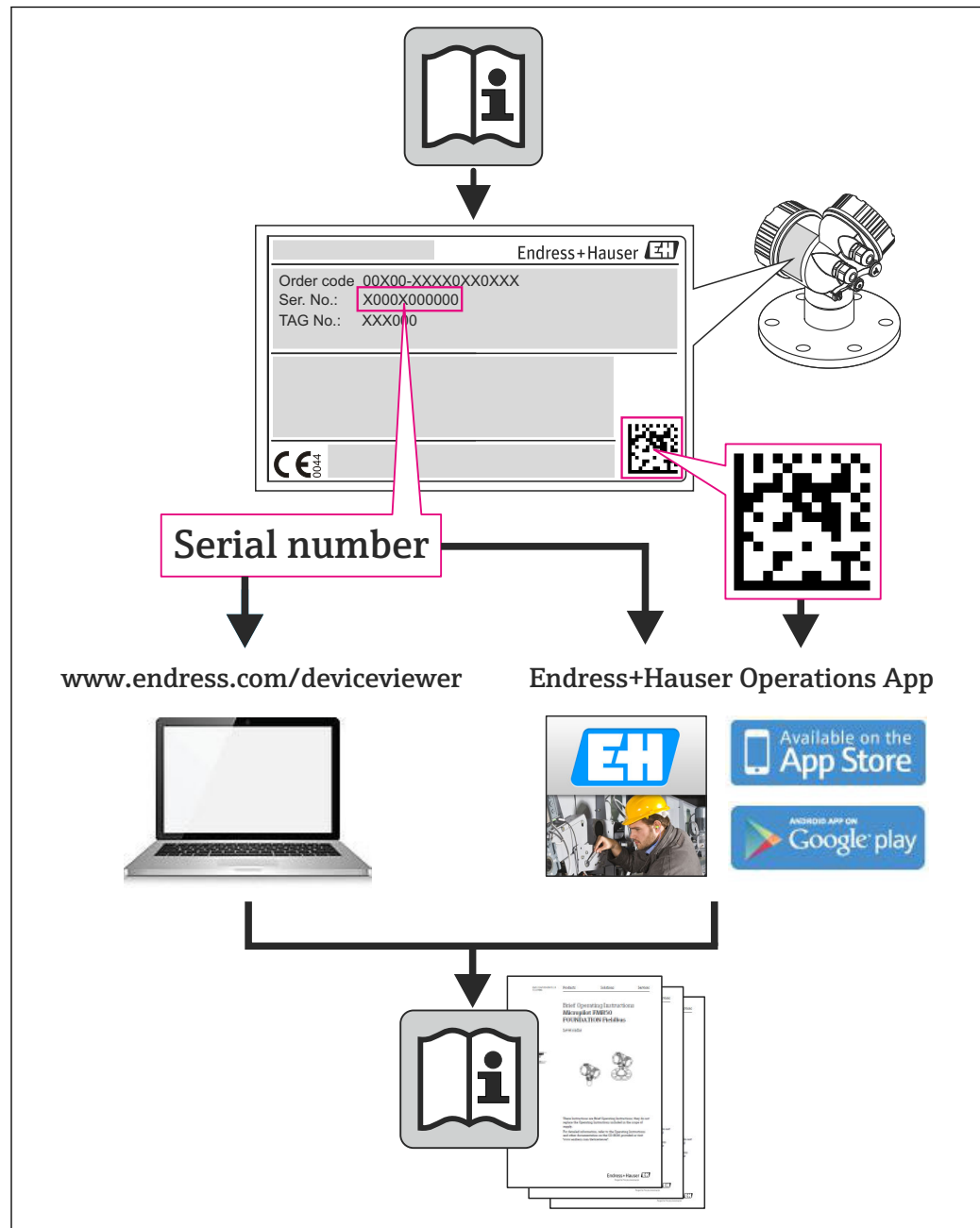

A0023555

- Make sure the document is stored in a safe place such that it is always available when working on or with the device.
- To avoid danger to individuals or the facility, read the "Basic safety instructions" section carefully, as well as all other safety instructions in the document that are specific to working procedures.
- The manufacturer reserves the right to modify technical data without prior notice. Your Endress+Hauser distributor will supply you with current information and updates to these Instructions.

Table of contents

1	Document information	5	7	Operation options	32
1.1	Document function	5	7.1	Overview of operating options	32
1.2	Symbols used	5	7.2	Operating concept	33
1.3	Documentation	6	7.3	Structure of the operating menu	33
1.4	Terms and abbreviations	7	7.4	Locking/unlocking operation	34
2	Basic safety instructions	8	7.5	Resetting to factory settings (reset)	35
2.1	Requirements concerning the staff	8	8	Integrating device via HART®	
2.2	Designated use	8		protocol	36
2.3	Workplace safety	8	8.1	HART process variables and measured	
2.4	Operational safety	8		values	36
2.5	Product safety	9	8.2	Device variables and measured values	37
3	Product description	10	9	Commissioning	38
3.1	Function	10	9.1	Post-installation check and function check ...	38
4	Incoming acceptance and product		9.2	Unlocking/locking configuration	38
	identification	11	9.3	Commissioning	38
4.1	Incoming acceptance	11	9.4	Selecting the language	39
4.2	Product identification	12	9.5	Measuring mode selection	39
4.3	Nameplates	13	9.6	For selecting the pressure engineering unit ...	40
4.4	Identification of sensor type	14	9.7	Position adjustment	40
4.5	Storage and transport	14	9.8	Configuring the damping	41
4.6	Scope of delivery	14	9.9	Configuring pressure measurement	41
5	Installation	16	9.10	Configuring level measurement	43
5.1	Installation conditions	16	9.11	Automatic density compensation	56
5.2	Additional mounting instructions	17	9.12	Linearization	59
5.3	Dimensions	17	9.13	Manual entry of a linearization table via	
5.4	Mounting the Waterpilot with a mounting			operating tool	62
	clamp	18	9.14	Backing up or duplicating the device data ...	63
5.5	Mounting the Waterpilot with a cable		10	Diagnostics and troubleshooting ...	64
	mounting screw	19	10.1	Troubleshooting	64
5.6	Mounting the terminal box	20	10.2	Diagnostic events	64
5.7	Mounting the TMT182 temperature head		10.3	Troubleshooting specific to Waterpilot	
	transmitter with terminal box	20		FMX21 with optional Pt100	67
5.8	Mounting the terminal strip for the Pt100		10.4	Troubleshooting specific to TMT182	
	passive (without TMT182)	21		temperature head transmitter	68
5.9	Post-installation check	21	10.5	Response of output to errors	68
6	Electrical connection	23	10.6	Firmware history	69
6.1	Connecting the device	23	11	Maintenance	70
6.2	Supply voltage	25	11.1	Exterior cleaning	70
6.3	Cable specifications	25	12	Repairs	71
6.4	Power consumption	25	12.1	General notes	71
6.5	Current consumption	26	12.2	Spare parts	71
6.6	Maximum load	26	12.3	Return	71
6.7	Connecting the measuring unit	27	12.4	Disposal	71
6.8	Post-connection check	31			

13	Overview of the operating menu	72
13.1	Overview of parameters in the "Expert" menu	75
14	Description of device parameters . . .	80
14.1	Expert → System	80
14.2	Expert → System → Instrument info	81
14.3	Expert → System → Management	83
14.4	Expert → Measurement → Measuring mode	83
14.5	Expert → Measurement → Basic setup	84
14.6	Expert → Measurement → Pressure	86
14.7	Expert → Measurement → Level	88
14.8	Expert → Measurement → Linearization	93
14.9	Expert → Measurement → Sensor limits	96
14.10	Expert → Measurement → Sensor trim	97
14.11	Expert → Output → Current output	98
14.12	Expert → Communication → HART config.	102
14.13	Expert → Communication → HART info	104
14.14	Expert → Communication → HART output	106
14.15	Expert → Communication → HART input	109
14.16	Expert → Application	111
14.17	Expert → Diagnosis	112
14.18	Expert → Diagnosis → Diagnostic list	114
14.19	Expert → Diagnosis → Event logbook	115
14.20	Expert → Diagnosis → Simulation	116
15	Accessories	118
15.1	Suspension clamp	118
15.2	Terminal box	118
15.3	Additional weight	118
15.4	Temperature head transmitter TMT182 (4 to 20 mA HART)	119
15.5	Pt-100 resistance thermometer	119
15.6	Cable mounting screws	119
15.7	Terminals	119
15.8	Cable shortening kit	119
15.9	Cable marking	119
15.10	Testing adapter	120
16	Technical data	122
16.1	Input	122
16.2	Output	124
16.3	Performance characteristics	127
16.4	Environment	129
16.5	Process	131
16.6	Additional technical data	131
Index	132





1 Document information

1.1 Document function







These Operating Instructions contain all the information that is required in various phases of the life cycle of the device: from product identification, incoming acceptance and storage, to mounting, connection, operation and commissioning through to troubleshooting, maintenance and disposal.

1.2 Symbols used



1.2.1 Safety symbols



Symbol	Meaning
	DANGER! This symbol alerts you to a dangerous situation. Failure to avoid this situation will result in serious or fatal injury.
	WARNING! This symbol alerts you to a dangerous situation. Failure to avoid this situation can result in serious or fatal injury.
	CAUTION! This symbol alerts you to a dangerous situation. Failure to avoid this situation can result in minor or medium injury.
	NOTE! This symbol contains information on procedures and other facts which do not result in personal injury.

1.2.2 Electrical symbols





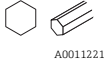





Symbol	Meaning	Symbol	Meaning
	Direct current		Alternating current
	Direct current and alternating current		Ground connection A grounded terminal which, as far as the operator is concerned, is grounded via a grounding system.
	Protective ground connection A terminal which must be connected to ground prior to establishing any other connections.		Equipotential connection A connection that has to be connected to the plant grounding system: This may be a potential equalization line or a star grounding system depending on national or company codes of practice.

1.2.3 Tool symbols

Symbol	Meaning
 A0011220	Flat blade screwdriver
 A0011219	Philips screwdriver

Symbol	Meaning
 A0011221	Allen key
 A0011222	Open-ended wrench

1.2.4 Symbols for certain types of information

Symbol	Meaning
	Permitted Procedures, processes or actions that are permitted.
	Preferred Procedures, processes or actions that are preferred.
	Forbidden Procedures, processes or actions that are forbidden.
	Tip Indicates additional information.
	Reference to documentation
	Reference to page
	Reference to graphic
	Series of steps
	Result of a step
	Help in the event of a problem
	Visual inspection

1.2.5 Symbols in graphics

Symbol	Meaning
1, 2, 3 ...	Item numbers
	Series of steps
A, B, C, ...	Views
A-A, B-B, C-C, ...	Sections

1.3 Documentation

 The document types listed are available:
In the Downloads area of the Endress+Hauser website: www.endress.com → Downloads

1.3.1 Technical Information (TI): planning aid for your device

TI00431P:

The document contains all the technical data on the device and provides an overview of the accessories and other products that can be ordered for the device.

1.3.2 Brief Operating Instructions (KA): getting the 1st measured value quickly

KA01189P:

The Brief Operating Instructions contain all the essential information from incoming acceptance to initial commissioning.

1.3.3 Safety Instructions (XA)

Depending on the approval, the following Safety Instructions (XA) are supplied with the device. They are an integral part of the Operating Instructions.

Directive	Type of protection	Category	Documentation	Option ¹⁾
ATEX	Ex ia IIC	II 2 G	XA00454P	BD
ATEX	Ex nA IIC	II 3 G	XA00485P	BE
IECEX	Ex ia IIC	n/a	XA00455P	IC
CSA C/US	Ex ia IIC	n/a	ZD00232P (960008976)	CE
FM	AEx ia IIC	n/a	ZD00231P (960008975)	FE
NEPSI	Ex ia IIC	n/a	XA00456P	NA
INMETRO	Ex ia IIC	n/a	XA01066P	MA

1) Product Configurator order code for "Approval"

 The nameplate indicates the Safety Instructions (XA) that are relevant to the device.

1.4 Terms and abbreviations

Term/abbreviation	Explanation
XA	Document type "Safety Instructions"
KA	Document type "Brief Operating Instructions"
BA	Document type "Operating Instructions"
SD	Document type "Special Documentation"
TD	Turn down Set span and zero-based span.

2 Basic safety instructions

2.1 Requirements concerning the staff

The personnel for installation, commissioning, diagnostics and maintenance must fulfill the following requirements:

- ▶ Trained, qualified specialists: must have a relevant qualification for this specific function and task
- ▶ Are authorized by the plant owner/operator
- ▶ Are familiar with federal/national regulations
- ▶ Before beginning work, the specialist staff must have read and understood the instructions in the Operating Instructions and supplementary documentation as well as in the certificates (depending on the application)
- ▶ Following instructions and basic conditions

The operating personnel must fulfill the following requirements:

- ▶ Being instructed and authorized according to the requirements of the task by the facility's owner-operator
- ▶ Following the instructions in these Operating Instructions

2.2 Designated use

2.2.1 Application and media

The Waterpilot FMX21 is a hydrostatic pressure sensor for measuring the level of fresh water, wastewater and salt water. The temperature is measured simultaneously in the case of sensor versions with a Pt100 resistance thermometer. An optional temperature head transmitter converts the Pt100 signal to a 4 to 20 mA signal with superimposed digital communication protocol HART 6.0.

2.2.2 Incorrect use

The manufacturer is not liable for damage caused by improper or non-designated use.

Verification for borderline cases:

- ▶ For special fluids and fluids for cleaning, Endress+Hauser is glad to provide assistance in verifying the corrosion resistance of fluid-wetted materials, but does not accept any warranty or liability.

2.3 Workplace safety

For work on and with the device:

- ▶ Wear the required personal protective equipment according to federal/national regulations.
- ▶ Switch off the supply voltage before connecting the device.

2.4 Operational safety

Risk of injury!

- ▶ Operate the device in proper technical condition and fail-safe condition only.
- ▶ The operator is responsible for interference-free operation of the device.

Modifications to the device

Unauthorized modifications to the device are not permitted and can lead to unforeseeable dangers.

- ▶ If, despite this, modifications are required, consult with Endress+Hauser.

Repairs

To ensure continued operational safety and reliability,

- ▶ Carry out repairs on the device only if they are expressly permitted.
- ▶ Observe federal/national regulations pertaining to repair of an electrical device.
- ▶ Use original spare parts and accessories from Endress+Hauser only.

Hazardous area

To eliminate danger to persons or the facility when the device is used in the approval-related area (e.g. explosion protection, pressure vessel safety):

- ▶ Check the nameplate to verify if the device ordered can be put to its intended use in the approval-related area.
- ▶ Observe the specifications in the separate supplementary documentation that is an integral part of these Instructions.

2.5 Product safety

This measuring device is designed in accordance with good engineering practice to meet state-of-the-art safety requirements, has been tested, and left the factory in a condition in which it is safe to operate.

It meets general safety standards and legal requirements. It also complies with the EC directives listed in the device-specific EC Declaration of Conformity. Endress+Hauser confirms this by affixing the CE mark to the device.

3 Product description

3.1 Function

The ceramic measuring cell is a dry measuring cell i.e. the pressure acts directly on the robust, ceramic process isolating diaphragm of the Waterpilot FMX21. Potential changes in air pressure are guided via a pressure compensation tube through the extension cable to the rear of the ceramic process isolating diaphragm and are compensated for. A pressure-dependent change in capacitance, caused by the movement of the process isolating diaphragm, is measured at the electrodes of the ceramic carrier. The electronics unit then converts this to a signal that is proportional to the pressure and linear to the level.

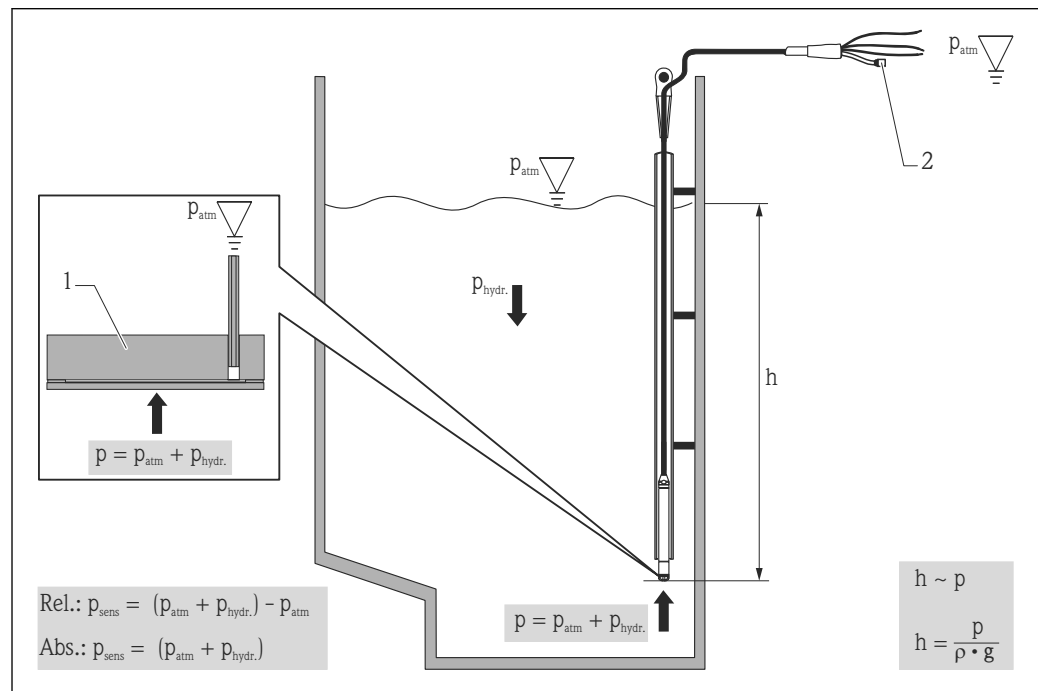

A0019140

- 1 Ceramic measuring cell
- 2 Pressure compensation tube
- h Height level
- p Total pressure = atmospheric pressure + hydrostatic pressure
- ρ Density of the medium
- g Acceleration due to gravity
- $p_{hydr.}$ Hydrostatic pressure
- p_{atm} Atmospheric pressure
- p_{sens} Pressure displayed on the sensor

4 Incoming acceptance and product identification

4.1 Incoming acceptance

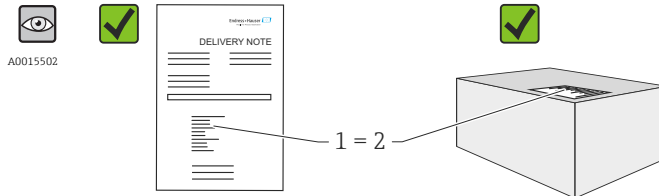

Is the order code on the delivery note (1) identical to the order code on the product sticker (2)?

A0016870

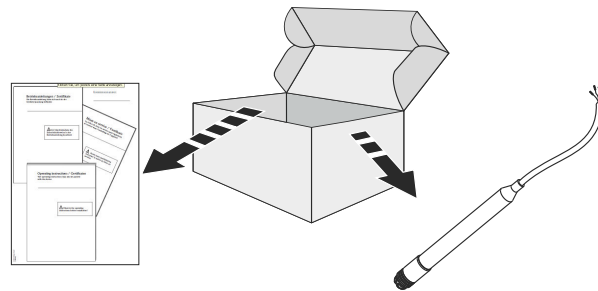

A0026535



Are the goods undamaged?

A0026536

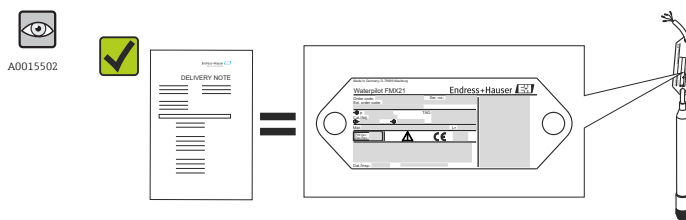

Do the data on the nameplate correspond to the order specifications and the delivery note?

A0026537

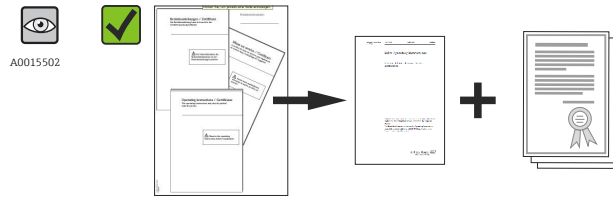

A0022106

Is the documentation available?
If required (see nameplate): Are the safety instructions (XA) present?

i If one of these conditions does not apply, please contact your Endress+Hauser sales office.

4.2 Product identification

The following options are available for identification of the measuring device:

- Nameplate specifications
- Order code with breakdown of the device features on the delivery note
- Enter serial numbers from nameplates in *W@M Device Viewer* (www.endress.com/deviceviewer): All information about the measuring device is displayed.

For an overview of the technical documentation provided, enter the serial number from the nameplates in the *W@M Device Viewer* (www.endress.com/deviceviewer)

4.3 Nameplates

4.3.1 Nameplates on extension cable

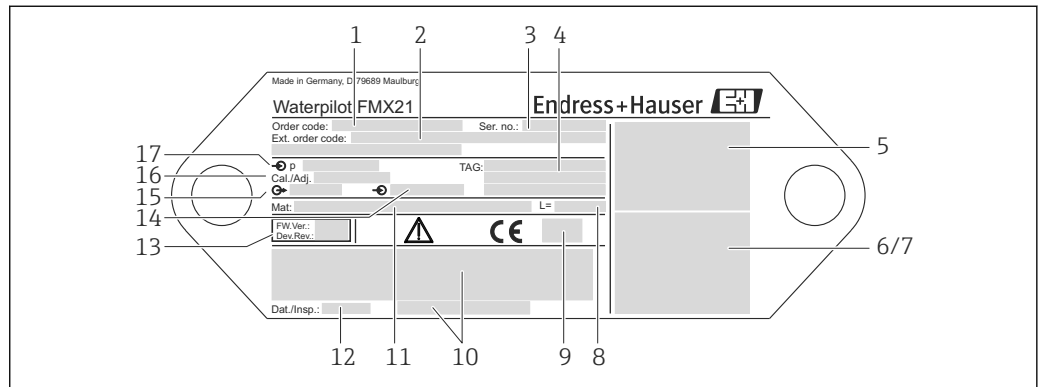

A0018902

- 1 Order code (shortened for reordering); The meaning of the individual letters and digits is explained in the order confirmation details.
- 2 Extended order number (complete)
- 3 Serial number (for clear identification)
- 4 TAG (device tag)
- 5 FMX21 connection diagram
- 6 Pt100 connection diagram (optional)
- 7 Warning (hazardous area), (optional)
- 8 Length of extension cable
- 9 Approval symbol, e.g. CSA, FM, ATEX (optional)
- 10 Text for approval (optional)
- 11 Materials in contact with process
- 12 Test date (optional)
- 13 Software version/device version
- 14 Supply voltage
- 15 Output signal
- 16 Set measuring range
- 17 Nominal measuring range

Additional nameplate for devices with approvals

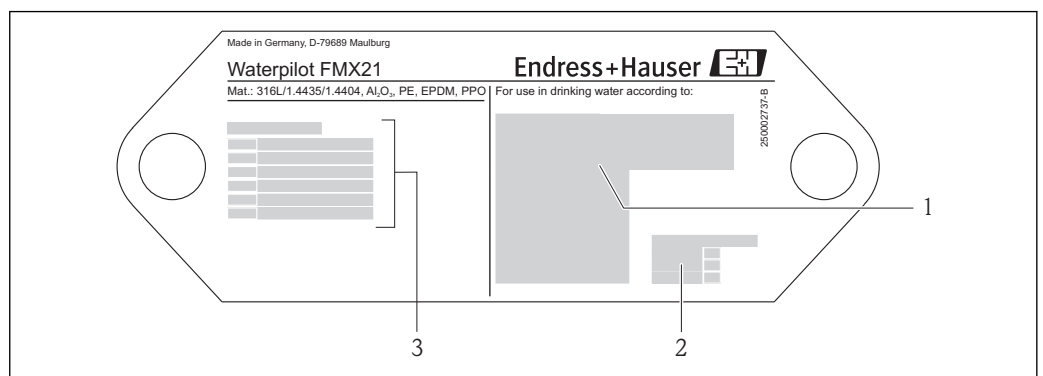

A0018905

- 1 Approval symbol (drinking water approval)
- 2 Reference to associated documentation
- 3 Approval number (marine approval)

4.3.2 Additional nameplate for devices with external diameter 22 mm (0.87 in) and 42 mm (1.65 in)

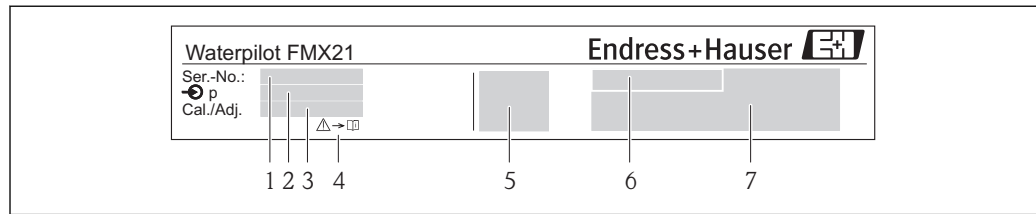

A0018804

- 1 Serial number
- 2 Nominal measuring range
- 3 Set measuring range
- 4 CE mark or approval symbol
- 5 Certificate number (optional)
- 6 Text for approval (optional)
- 7 Reference to documentation

4.4 Identification of sensor type

With relative pressure or absolute pressure sensors, the "Pos.zero adjust" parameter is displayed in the operating menu. With absolute pressure sensors, the "Calib. offset" parameter is displayed in the operating menu.

4.5 Storage and transport

4.5.1 Storage conditions

Use original packaging.

Store the measuring device in clean and dry conditions and protect from damage caused by shocks (EN 837-2).

Storage temperature range

- FMX21: -40 to +80 °C (-40 to +176 °F)
- TMT182: -40 to +100 °C (-40 to +212 °F)
- Terminal box: -40 to +80 °C (-40 to +176 °F)

4.5.2 Transporting the product to the measuring point

⚠ WARNING

Incorrect transport!

Device or cable may become damaged, and there is a risk of injury!

- ▶ Transport measuring device in the original packaging.
- ▶ Follow the safety instructions and transport conditions for devices weighing more than 18 kg (39.6 lbs).

4.6 Scope of delivery

The scope of delivery comprises:

- Waterpilot FMX21, optionally with integrated Pt100 resistance thermometer
- Optional accessories

Documentation supplied:

- The Operating Instructions BA00380P are available on the internet. → see: www.de.endress.com → Downloads.
- Brief Operating Instructions KA01189P
- Final inspection report
- Drinking water approvals (optional): SD00289P, SD00319P, SD00320P
- Devices that are suitable for use in hazardous areas: Additional documentation e.g. Safety Instructions (XA, ZD)

5 Installation

5.1 Installation conditions

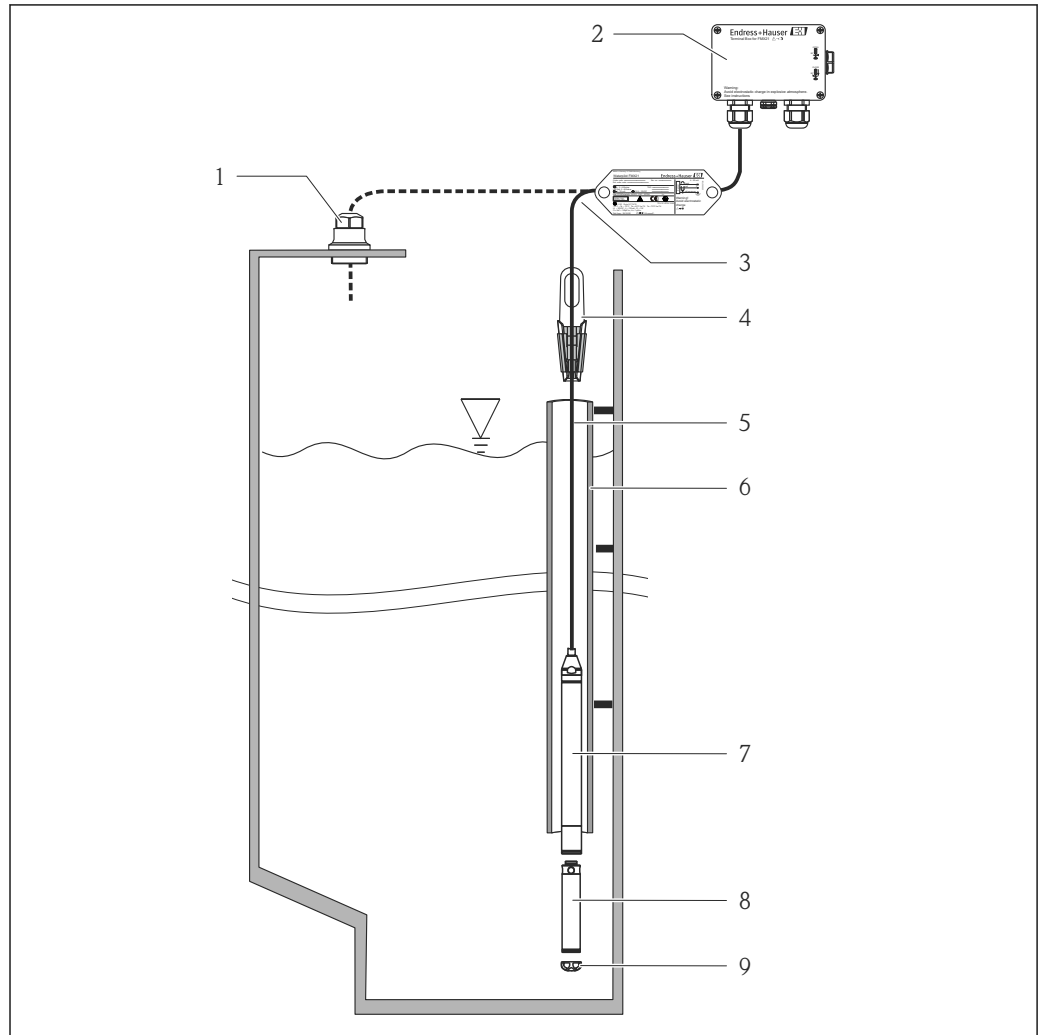

A0018770

- 1 Cable mounting screw (can be ordered as an accessory)
- 2 Terminal box (can be ordered as an accessory)
- 3 Bending radius of extension cable > 120 mm (4.72 in)
- 4 Mounting clamp (can be ordered as an accessory)
- 5 Extension cable
- 6 Guide tube
- 7 Waterpilot FMX21
- 8 Additional weight can be ordered as an accessory for the FMX21 with external diameter of 22 mm (0.87 in) and 29 mm (1.14 in)
- 9 Protection cap

5.2 Additional mounting instructions

- Cable length
 - Customer-specific in meters or feet.
 - Limited cable length when performing installation with freely suspended device with cable mounting screw or mounting clamp, as well as for FM/CSA approval: max. m/ft. 300 m (984 ft).
- Sideways movement of the level probe can result in measuring errors. For this reason, install the probe at a point free from flow and turbulence, or use a guide tube. The internal diameter of the guide tube should be at least 1 mm (0.04 in) greater than the external diameter of the selected FMX21.
- To avoid mechanical damage to the measuring cell, the device is equipped with a protection cap.
- The cable must end in a dry room or a suitable terminal box. The terminal box from Endress+Hauser provides optimum protection from the effects of humidity and weather conditions and is suitable for outdoor installation →  118.
- Cable length tolerance: < 5 m (16 ft): ±17.5 mm (0.69 in); > 5 m (16 ft): ±0.2 %
- If the cable is shortened, the filter at the pressure compensation tube must be reattached. Endress+Hauser offers a cable shortening kit for this purpose (documentation SD00552P/00/A6).
- Endress+Hauser recommends using twisted, shielded cable.
- In shipbuilding applications, measures are required to restrict the spread of fire along cable looms.
- The length of the extension cable depends on the intended level zero point. The height of the protection cap must be taken into consideration when designing the layout of the measuring point. The level zero point (E) corresponds to the position of the process isolating diaphragm. Level zero point = E; tip of probe = L (see the following diagram).

5.3 Dimensions

For dimensions, please refer to the Technical Information TI00431P/00/EN, "Mechanical construction" section (see also: www.de.endress.com → Downloads → Media Type: Documentation).

5.4 Mounting the Waterpilot with a mounting clamp

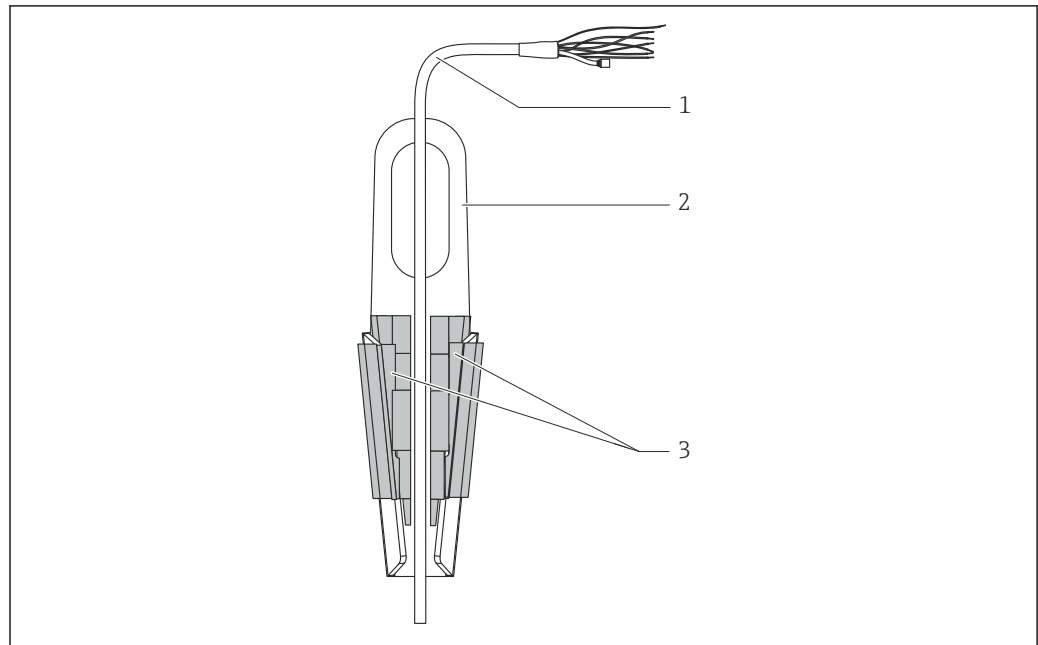

A0018793

- 1 *Extension cable*
- 2 *Suspension clamp*
- 3 *Clamping jaws*

5.4.1 Mounting the suspension clamp:

1. Installing the mounting clamp (item 2) . When selecting the place to attach the unit, note the weight of the extension cable (item 1) and of the device.
2. Raise the clamping jaws (item 3). Hold the extension cable in position (item 1) between the clamping jaws as illustrated in the diagram.
3. Hold the extension cable in position (item 1) and push the clamping jaws (item 3) back down. Tap the clamping jaws gently from above to fix them in place.

5.5 Mounting the Waterpilot with a cable mounting screw

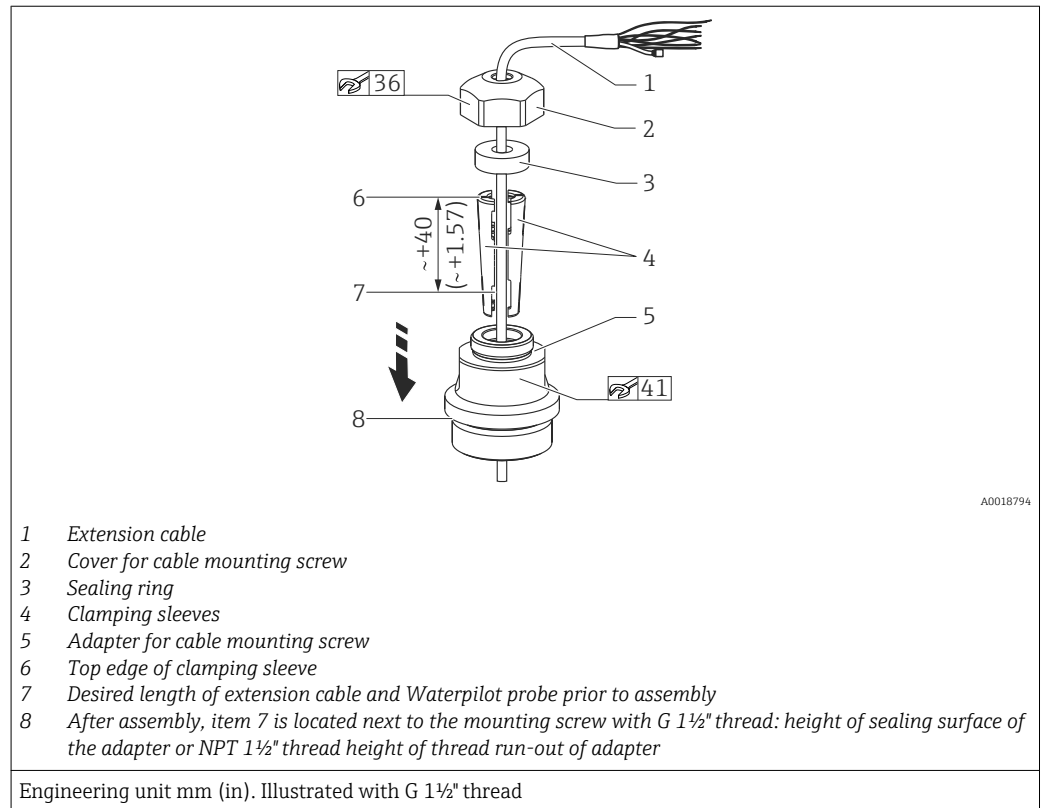

i If you want to lower the level probe to a certain depth, position the top edge of the clamping sleeve 40 mm (4.57 in) higher than the required depth. Then push the extension cable and the clamping sleeve into the adapter as described in Step 6 in the following section.

5.5.1 Mount cable mounting screw with G 1½" or NPT 1½" thread:

1. Mark the desired length of extension cable on the extension cable
2. Insert the probe through the measuring aperture and carefully lower on the extension cable. Fix the extension cable to prevent it from slipping.
3. Push the adapter (item 5) over the extension cable and screw it tightly into the measuring aperture.
4. Push the sealing ring (item 3) and cover (item 2) onto the cable from above. Press the sealing ring into the cover.
5. Place clamping sleeves (item 4) around the extension cable (item 1) at the marked position as illustrated in the diagram.
6. Push the extension cable with the clamping sleeves (item 4) into the adapter (item 5)
7. Slide the cover (item 2) with sealing ring (item 3) onto the adapter (item 5) and screw tightly to the adapter.

i To remove the cable mounting screw, perform this sequence of steps in reverse.

CAUTION

Risk of injury!

- Use only in unpressurized vessels.

5.6 Mounting the terminal box

The optional terminal box is mounted using four screws (M4). For the dimensions of the terminal box, please see the Technical Information TI0043 1P/00/ EN, "Mechanical construction" section (see also: www.de.endress.com → Downloads → Media Type: Documentation).

5.7 Mounting the TMT182 temperature head transmitter with terminal box

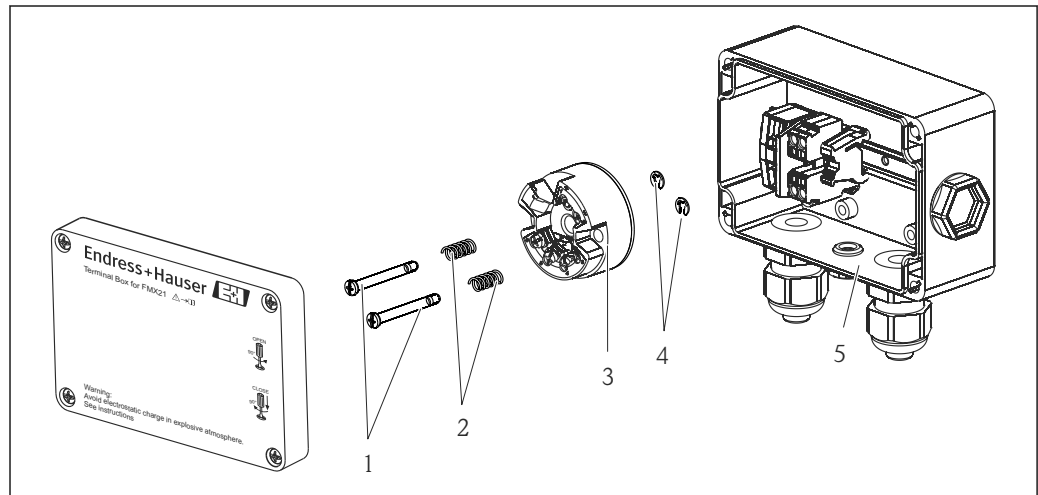

- 1 Mounting screws
 2 Mounting springs
 3 TMT182 temperature head transmitter
 4 Circlips
 5 Terminal box



Only open the terminal box with a screwdriver.

WARNING

Risk of explosion!

- ▶ The TMT182 is not designed for use in hazardous areas.

5.7.1 Mounting the temperature head transmitter:

1. Guide the mounting screws (item 1) with the mounting springs (item 2) through the hole in the temperature head transmitter (item 3)
2. Secure the mounting screws with the circlips (item 4). Circlips, mounting screws and springs are included in the scope of delivery for the temperature head transmitter.
3. Screw the temperature head transmitter into the field housing tightly. (width of screwdriver blade max. 6 mm (0.24 in))

NOTICE

Avoid damage to the temperature head transmitter.

- ▶ Do not overtighten the mounting screw too.

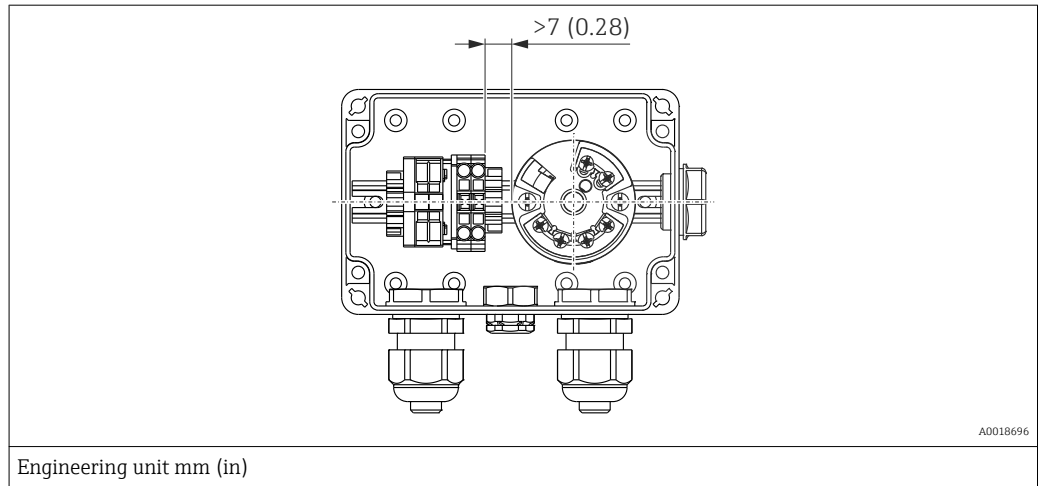

NOTICE

Incorrect connection!

- ▶ A distance of >7 mm (> 0.28) must be maintained between the terminal strip and the TMT182 temperature head transmitter.

5.8 Mounting the terminal strip for the Pt100 passive (without TMT182)

If the FMX21 with optional Pt100 is supplied without the optional TMT182 temperature head transmitter, a terminal strip is provided with the terminal box for the purpose of wiring the Pt100.

⚠ WARNING

Risk of explosion!

- ▶ The Pt100, as well as the terminal strip, are not designed for use in hazardous areas.

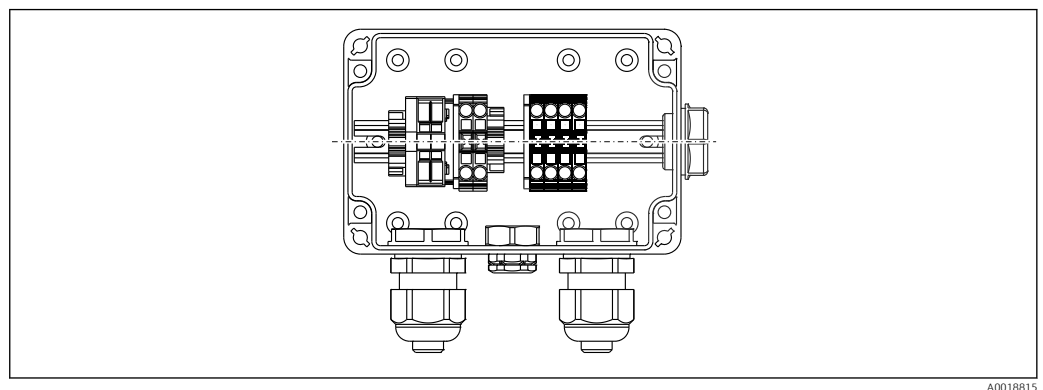

5.9 Post-installation check

<input type="checkbox"/>	Is the device undamaged (visual inspection)?
<input type="checkbox"/>	Does the device conform to the measuring point specifications? For example: <ul style="list-style-type: none"> ▪ Process temperature ▪ Process pressure ▪ Ambient temperature ▪ Measuring range
<input type="checkbox"/>	Are the measuring point identification and labeling correct (visual inspection)?

<input type="checkbox"/>	Is the device adequately protected from precipitation and direct sunlight?
<input type="checkbox"/>	Check that all screws are firmly seated.

6 Electrical connection

⚠ WARNING

Electrical safety is compromised by an incorrect connection!

- ▶ When using the measuring device in a hazardous area, the relevant national standards and guidelines as well as the Safety Instructions (XAs) or installation or control drawings (ZDs) must be adhered to. All data relating to explosion protection can be found in separate documentation which is available on request. This documentation is supplied with the devices as standard → 7

6.1 Connecting the device

⚠ WARNING

Electrical safety is compromised by an incorrect connection!

- ▶ The supply voltage must match the supply voltage specified on the nameplate → 13
- ▶ Switch off the supply voltage before connecting the device.
- ▶ The cable must end in a dry room or a suitable terminal box. The IP66/IP67 terminal box with GORE-TEX® filter from Endress+Hauser → 20 is suitable for outdoor installation.
- ▶ Connect the device in accordance with the following diagrams. Reverse polarity protection is integrated into the Waterpilot FMX21 and the TMT182 temperature head transmitter. Changing the polarities will not result in the destruction of the devices.
- ▶ A suitable circuit breaker should be provided for the device in accordance with IEC/EN 61010.

6.1.1 Waterpilot with Pt100

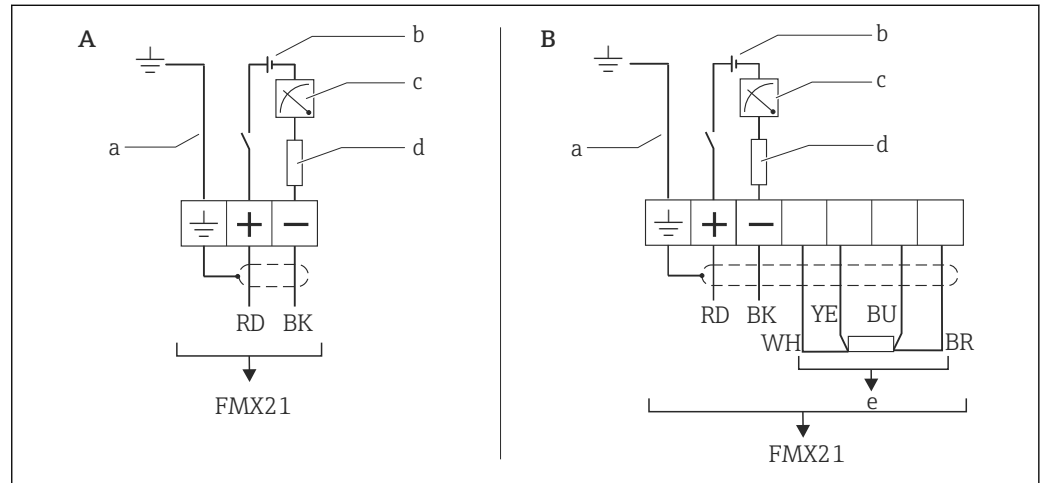

A0019441

A Waterpilot FMX21

B Waterpilot FMX21 with Pt100 (not for use in hazardous areas); option "NB", Product Configurator order code for "Accessories"

a Not for the FMX21 with external diameter of 29 mm (1.14 in)

b 10.5 to 30 V DC (hazardous area), 10.5 to 35 V DC

c 4...20 mA

d Resistance (R_t)

e Pt100

6.1.2 Waterpilot with Pt100 and TMT182 temperature head transmitter (4 to 20 mA)

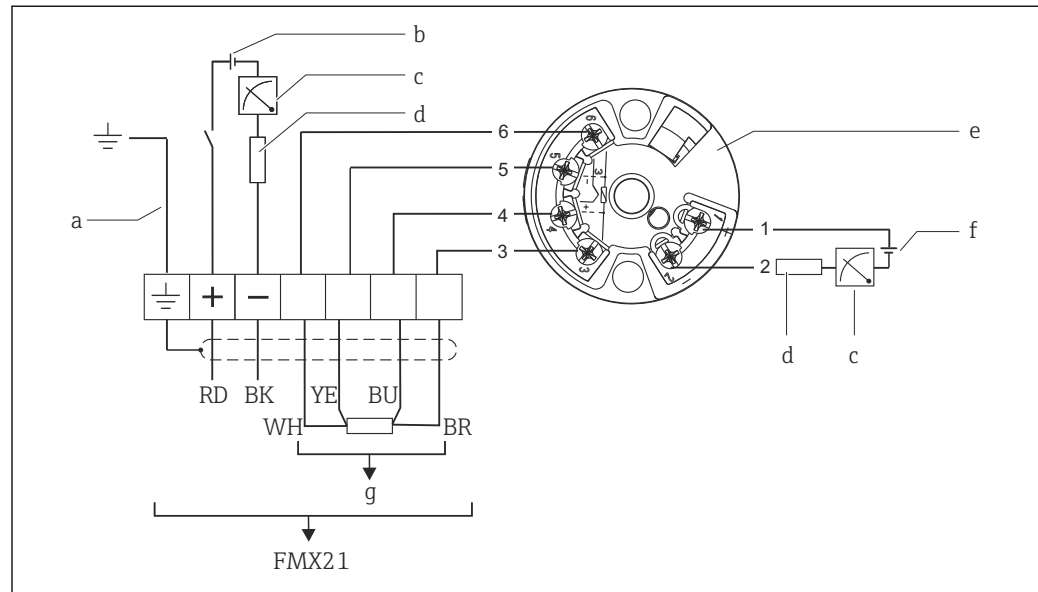

A0018780

- a Not for the FMX21 with external diameter of 29 mm (1.14 in)
- b 10.5 to 35 V DC
- c 4...20 mA
- d Resistance (R_L)
- e Temperature head transmitter TMT182 (4 to 20 mA) (not for use in hazardous areas)
- f 11.5 to 35 V DC
- g Pt100

Ordering information: options "NB" and "PT", Product Configurator order code for "Accessories mounted" and "Accessories enclosed"

6.1.3 Wire colors

RD = red, BK = black, WH = white, YE = yellow, BU = blue, BR = brown

Connection classification as per IEC 61010-1:

- Overvoltage category 1
- Pollution level 1

6.1.4 Connection data

Connection classification as per IEC 61010-1:

- Overvoltage category 1
- Pollution level 1

Connection data in the hazardous area

See relevant XA.

6.2 Supply voltage

WARNING

Supply voltage might be connected!

Risk of electric shock and/or explosion!

- ▶ When using the measuring device in hazardous areas, installation must comply with the corresponding national standards and regulations as well as the Safety Instructions.
- ▶ All explosion protection data are given in separate documentation which is available upon request. The Ex documentation is supplied as standard with all devices approved for use in explosion hazardous areas.

6.2.1 FMX21 + Pt100 (optional)

- 10.5 to 35 V (not hazardous areas)
- 10.5 to 30 V (hazardous areas)

6.2.2 TMT182 temperature head transmitter (optional)

11.5 to 35 V DC

6.3 Cable specifications

In the following cases, Endress+Hauser recommends the use of a shielded cable as the cable extension:

- For large distances between the end of the extension cable and the display and/or evaluation unit
- For large distances between the end of the extension cable and the temperature head transmitter
- When directly connecting the Pt100 signal to a display and/or evaluation unit

 The extension cables are shielded for device versions with external diameters of 22 mm (0.87 in) and 42 mm (1.65 in).

6.3.1 FMX21 + Pt100 (optional)

- Commercially available instrument cable
- Terminals, terminal box: 0.08 to 2.5 mm² (28 to 14 AWG)

6.3.2 TMT182 temperature head transmitter (optional)

- Commercially available instrument cable
- Terminals, terminal box: 0.08 to 2.5 mm² (28 to 14 AWG)
- Transmitter connection: max. 1.75 mm² (15 AWG)

6.4 Power consumption

6.4.1 FMX21 + Pt100 (optional)

- ≤ 0.805 W at 35 V DC (non-hazardous area)
- ≤ 0.690 W at 30 V DC (hazardous area)

6.4.2 TMT182 temperature head transmitter (optional)

≤ 0.805 W at 35 V DC

6.5 Current consumption

6.5.1 FMX21 + Pt100 (optional)

- Max. current consumption: ≤ 23 mA
Min. current consumption: ≥ 3.6 mA
- Pt100: ≤ 0.6 mA

6.5.2 TMT182 temperature head transmitter (optional)

- Max. current consumption: ≤ 23 mA
- Min. current consumption: ≥ 3.5 mA
- Pt100 via temperature head transmitter: ≤ 0.6 mA

6.6 Maximum load

The maximum load resistance depends on the supply voltage (U) and must be determined individually for each current loop, see formula and diagrams for FMX21 and temperature head transmitter.

The total resistance resulting from the resistances of the connected devices, the connecting cable and, where applicable, the resistance of the extension cable may not exceed the load resistance value.

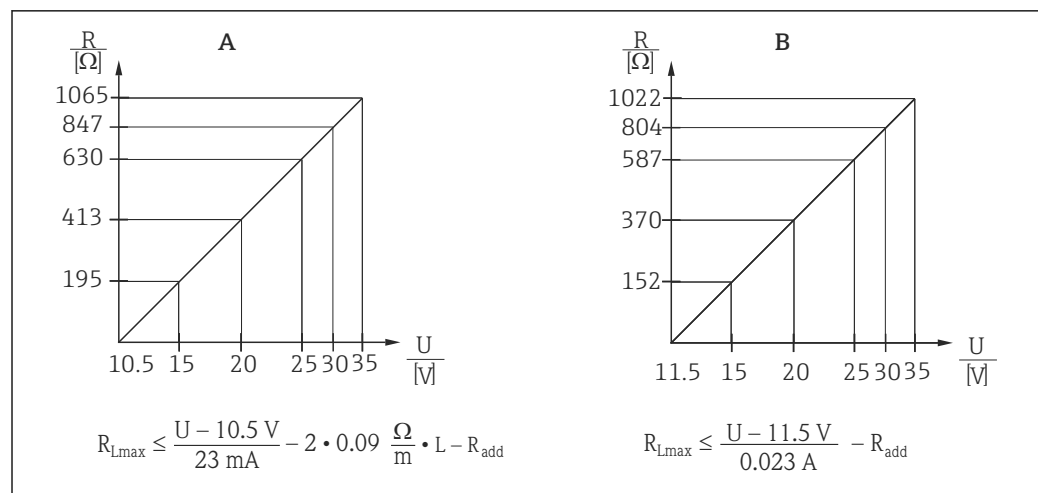

A0026500-EN

A FMX21 load chart for estimating the load resistance. Additional resistances, such as the resistance of the extension cable, have to be subtracted from the value calculated as shown in the equation.

B Load diagram for TMT182 temperature head transmitter for estimating the load resistance. Additional resistances must be subtracted from the value calculated as shown in the equation

R_{Lmax} Max. load resistance [Ω]

R_{add} Additional resistances, such as resistance of the evaluation unit and/or display unit, cable resistance [Ω]

U Supply voltage [V]

L Basic length of extension cable [m] (cable resistance per wire 0.09 Ω /m)

- **i** When using the measuring device in a hazardous area, the relevant national standards and regulations as well as the Safety Instructions or installation or control drawings (XA) must be adhered to.
- When operating via a handheld terminal or via a PC with an operating program, a minimum communication resistance of 250 Ω must be taken into account.

6.7 Connecting the measuring unit

6.7.1 Overvoltage protection

To protect the Waterpilot and the TMT182 temperature head transmitter from large interference voltage peaks, Endress+Hauser recommends installing overvoltage protection upstream and downstream of the display and/or evaluation unit as shown in the graphic.

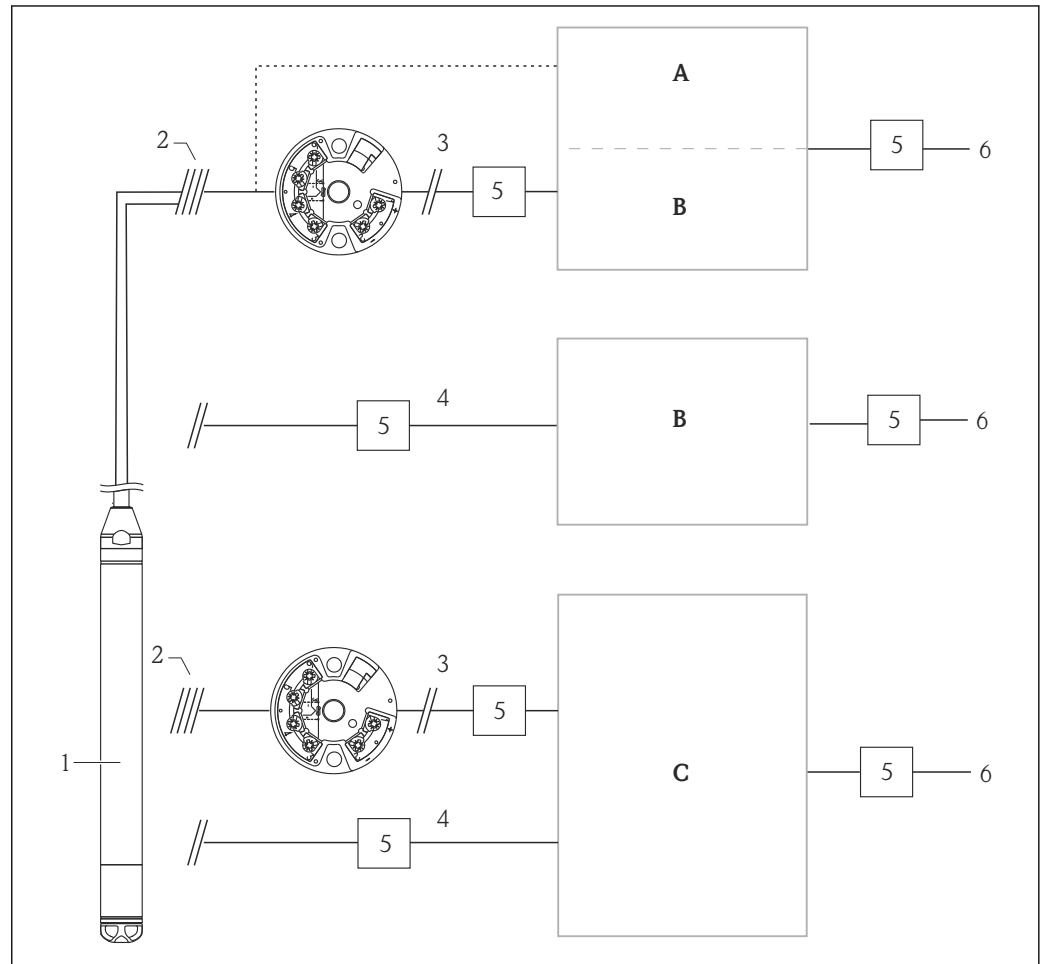

A0018941

- A Power supply, display and evaluation unit with one input for Pt100
- B Power supply, display and evaluation unit with one input for 4 to 20 mA
- C Power supply, display and evaluation unit with two inputs for 4 to 20 mA
- 1 Waterpilot FMX21 HART
- 2 Connection for integrated Pt100 in the FMX21
- 3 4 to 20 mA HART (temperature)
- 4 4 to 20 mA HART (level)
- 5 Overvoltage protection, e.g. HAW from Endress+Hauser (not for use in hazardous areas).
- 6 Power supply

i Further information on the TMT182 temperature head transmitter for HART applications from Endress+Hauser can be found in the Technical Information TI00078R/09/EN.

6.7.2 Connecting the Commubox FXA195

The Commubox FXA195 connects intrinsically safe transmitters with HART protocol to the USB interface of a computer. This enables remote operation of the transmitter using the Endress+Hauser operating program FieldCare. The power is supplied to the Commubox via

the USB interface. The Commubox is also suitable for connecting to intrinsically safe circuits. For further information, see the Technical Information TI00404F/00/EN.

6.7.3 Connecting the Field Xpert SFX

Compact, flexible and robust industrial handheld terminal for remote configuration and for obtaining measured values via the HART current output (4 to 20 mA). For details, see Operating Instructions BA00060S/04/EN.

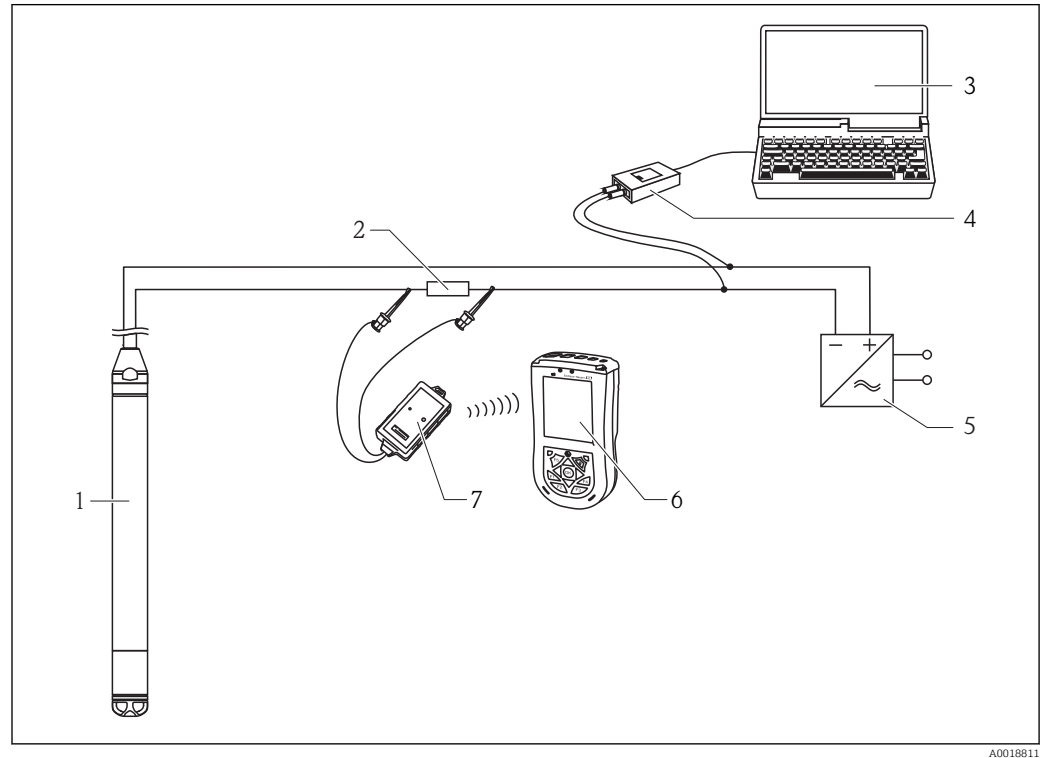

A0018811

- 1 Waterpilot FMX21
- 2 Required communication resistor $\geq 250 \Omega$
- 3 Computer with operating tool (e.g. FieldCare)
- 4 Commubox FXA195 (USB)
- 5 Transmitter power supply unit, e.g. RN221N (with communication resistor)
- 6 Field Xpert SFX
- 7 VIATOR Bluetooth modem with connecting cable

i Only use certified operating devices in hazardous area!

⚠ WARNING

Risk of explosion!

- ▶ Do not change the battery of the handheld terminal in the hazardous area.
- ▶ When using the measuring device in a hazardous area, the relevant national standards and regulations as well as the Safety Instructions (XAs) or installation or control drawings (ZDs) must be adhered to.

6.7.4 Connecting for air pressure compensation with external measured value

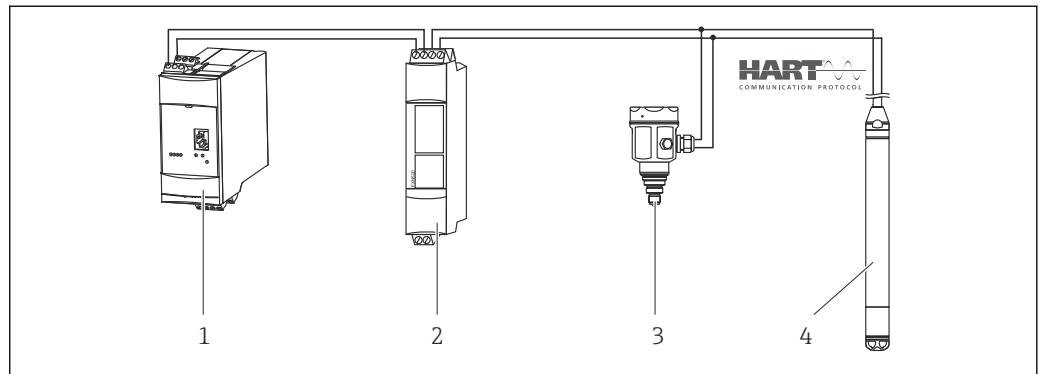

A0018757

- 1 Fieldgate FXA520
- 2 Multidrop connector FXN520
- 3 Cerabar
- 4 Waterpilot FMX21

For applications in which condensation may occur, the use of an absolute pressure probe is recommended. For level measurement using an absolute pressure probe, the measured value is affected by fluctuations in the ambient air pressure. To correct the resulting measured error, you can connect an external absolute pressure sensor (e.g. Cerabar) to the HART signal cable, switch the Waterpilot to burst mode and operate the Cerabar in "Electr. Delta P" mode.

By switching on the "Electr. Delta P" application, the external absolute pressure sensor calculates the difference between the two pressure signals and can thus determine the level precisely. Only one level measured value can be corrected in this way.

i If using intrinsically safe devices, the regulations which apply to interconnecting intrinsically safe circuits as outlined in IEC 60079-14 (proof of intrinsic safety) must be observed.

6.7.5 Connecting an external temperature sensor/temperature head transmitter for density compensation

The Waterpilot FMX21 can correct measured errors that result from fluctuations in the density of the water caused by temperature. Users can choose from the following options:

Use the internally measured sensor temperature of the FMX21

The internally measured sensor temperature is calculated in the Waterpilot FMX21 for density compensation. The level signal is thus corrected according to the density characteristic line of the water.

Use the optional internal Pt100 temperature sensor for density compensation in a suitable HART master (e.g. PLC)

The Waterpilot FMX21 is available with an optional Pt100 temperature sensor. Endress+Hauser additionally offers the TMT182 temperature head transmitter to convert the Pt100 signal to a 4 to 20 mA HART signal. The temperature and pressure signal is requested by a HART master (e.g. PLC), where a corrected level value can be generated using a stored linearization table or density function (of a chosen medium).

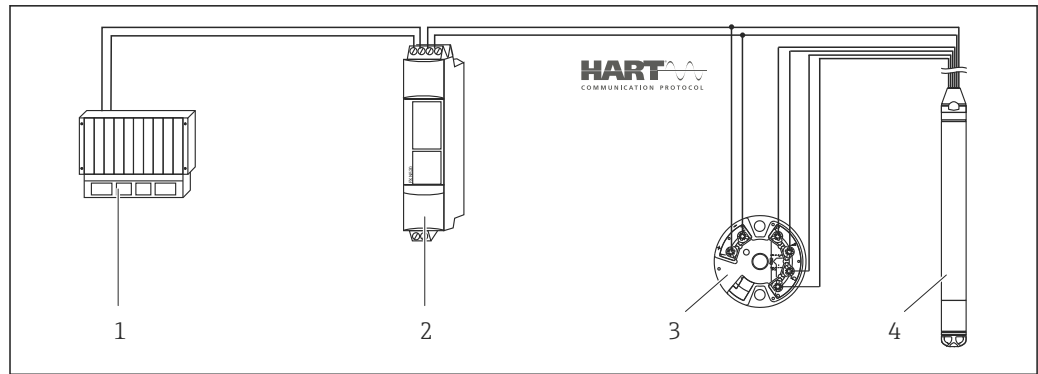

A0018763

- 1 HART master, e.g. PLC (programmable logic controller)
- 2 Multidrop connector FXN520
- 3 Temperature head transmitter TMT182
- 4 Waterpilot FMX21

Use an external temperature signal which is transmitted to the FMX21 via HART burst mode

The Waterpilot FMX21 is available with an optional Pt100 temperature sensor. In this case, the signal of the Pt100 is analyzed using a HART-compliant (min. HART 5.0) temperature head transmitter that supports burst mode. The temperature signal can thus be transmitted to the FMX21. The FMX21 uses this signal for density correction of the level signal.



The TMT182 temperature head transmitter is not suitable for this configuration.

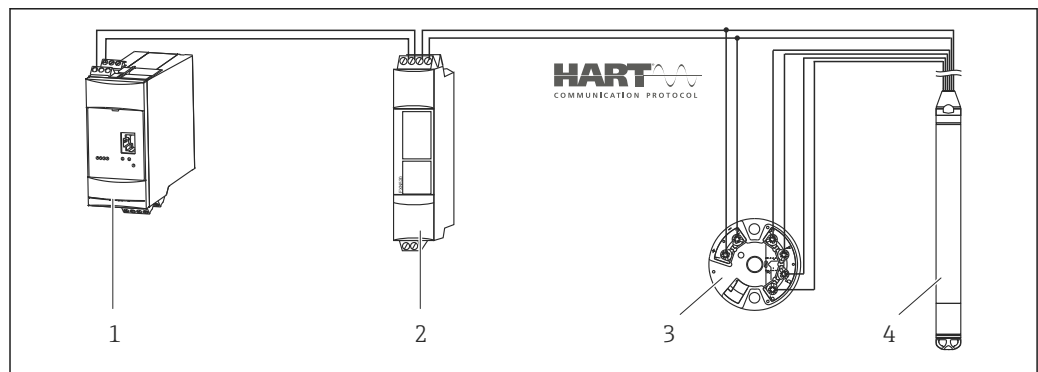

A0018764

- 1 Fieldgate FXA520
- 2 Multidrop connector FXN520
- 3 Temperature head transmitter TMT182 (burst mode)
- 4 Waterpilot FMX21

Without additional compensation due to the anomaly of water, errors of up to 4% may occur at a temperature of +70 °C (+158 °F), for example. With density compensation, this error can be decreased to 0.5 % in the entire temperature range from 0 to +70 °C (+32 to +158 °F).



For further information on the devices, please refer to the relevant Technical Information:

- TI00078R: Temperature head transmitter TMT182 (4 to 20 mA HART)
- TI00369F: Fieldgate FXA520
- TI00400F: Multidrop connector FXN520

6.8 Post-connection check

<input type="checkbox"/>	Is the device or cable undamaged (visual check)?
<input type="checkbox"/>	Do the cables comply with the requirements ?
<input type="checkbox"/>	Do the cables have adequate strain relief?
<input type="checkbox"/>	Are all cable glands installed, securely tightened and leak-tight?
<input type="checkbox"/>	Does the supply voltage match the specifications on the nameplate?
<input type="checkbox"/>	Is the terminal assignment correct ?

7 Operation options

Endress+Hauser offers comprehensive measuring point solutions with display and/or evaluation units for the Waterpilot FMX21 and TMT182 temperature head transmitter.

 Your Endress+Hauser service organization would be glad to be of service if you have any other questions. Contact addresses can be found on the website at www.endress.com/worldwide

7.1 Overview of operating options

7.1.1 Operation using Endress+Hauser operating program

The FieldCare operating program is an Endress+Hauser plant asset management tool based on FDT technology. With FieldCare, you can configure all Endress+Hauser devices as well as devices from other manufacturers that support the FDT standard.

Hardware and software requirements can be found on the Internet:

www.de.endress.com → Search: FieldCare → FieldCare → Technical Data.

FieldCare supports the following functions:

- Configuration of transmitters in online/offline mode
- Loading and saving device data (upload/download)
- Documentation of the measuring point

Connection options:

- HART via Commubox FXA195 and the USB port of a computer
- HART via FXA520 Fieldgate

-  Further information on FieldCare and software download can be found on the internet (www.de.endress.com ® Downloads ® Text Search: FieldCare).
- Connecting the Commubox FXA195
 - As not all internal device dependencies can be mapped in offline operation, the consistency of the parameters must be checked once again before they are transmitted to the device.

7.1.2 Operation using Field Xpert SFX

Compact, flexible and robust industrial handheld terminal for remote configuration and for obtaining measured values via the HART current output or FOUNDATION Fieldbus. For details, see the Operating Instructions BA00060S/04.

7.2 Operating concept

Operation with an operating menu is based on an operation concept with "user roles" .

User role	Meaning
Operator	Operators are responsible for the devices during normal "operation". This is usually limited to reading process values either directly at the device or in a control room. If the work with the devices goes beyond reading, it concerns simple, application-specific functions that are used in operation. Should an error occur, these users simple forward the information on the errors but do not intervene themselves.
Maintenance	Service engineers usually work with the devices in the phases following device commissioning. They are primarily involved in maintenance and troubleshooting activities for which simple settings have to be made at the device. Technicians work with the devices over the entire life cycle of the product. Thus, commissioning and advanced settings and configurations are some of the tasks they have to carry out.
Expert	Experts work with the devices over the entire life cycle of the device, but, in part, have high requirements on the devices. Individual parameters/functions from the overall functionality of the devices are required for this purpose time and again. In addition to technical, process-oriented tasks, experts can also perform administrative tasks (e.g. user administration). "Experts" can avail of the entire parameter set.

7.3 Structure of the operating menu

User role	Submenu	Meaning/use
Operator	Display/ operat.	Contains parameters that are needed to configure the measured value display (selecting the values displayed, display format, etc.). With this submenu, users can change the measured value display without affecting the actual measurement.
Maintenance	setup	<p>Contains all the parameters that are needed to commission measuring operations. This submenu has the following structure:</p> <ul style="list-style-type: none"> ▪ Standard setup parameters A wide range of parameters, which can be used to configure a typical application, is available at the start. The measuring mode selected determines which parameters are available. After making settings for all these parameters, the measuring operation should be completely configured in the majority of cases. ▪ "Extended setup" submenu The "Extended setup" submenu contains additional parameters for more in-depth configuration of the measurement operation, for conversion of the measured value and for scaling the output signal. This menu is split into additional submenus depending on the measuring mode selected.

User role	Submenu	Meaning/use
Maintenance	Diagnosis	<p>Contains all the parameters that are needed to detect and analyze operating errors. This submenu has the following structure:</p> <ul style="list-style-type: none"> ▪ Diagnostic list contains up to 10 currently pending error messages. ▪ Event logbook contains the last 10 error messages (no longer pending). ▪ Instrument info contains information for identifying the device. ▪ Measured values contains all current measured values. ▪ Simulation Is used to simulate pressure, level, current and alarm/warning. ▪ Enter reset code
Expert	Expert	<p>Contains all the parameters of the device (including those already in one of the submenus). The "Expert" submenu is structured by the function blocks of the device. It thus contains the following submenus:</p> <ul style="list-style-type: none"> ▪ System contains all device parameters that do not affect either measurement or integration into a distributed control system. ▪ Measurement contains all parameters for configuring the measurement. ▪ Output contains all parameters for configuring the current output. ▪ Communication contains all parameters for configuring the HART interface. ▪ Diagnosis contains all parameters required to detect and analyze operating errors.

7.4 Locking/unlocking operation



Once you have entered all the parameters, you can lock your entries against unauthorized and undesired access.

The "Operator code" parameter is used to lock/unlock the device.

Operator code

Navigation	 Setup → Extended setup → Operator code
Read permission	Operators/Service engineers/Expert
Write permission	Operators/Service engineers/Expert
Description	Use this function to enter a code to lock or unlock operation.
User entry	<ul style="list-style-type: none"> ▪ To lock: Enter a number ≠ the release code (value range: 1 to 65535). ▪ To unlock: Enter the release code.
Factory setting	0
Note	<p>The release code is "0" in the order configuration. Another release code can be defined in the "Code definition" parameter. If the user has forgotten the release code, the release code can be visible by entering the number "5864".</p> <p>The release code is defined in the "Code definition" parameter.</p>

Code definition

Navigation	  Setup → Extended setup → Code definition
Read permission	Operators/Service engineers/Expert
Write permission	Operators/Service engineers/Expert
Description	Use this function to enter a release code with which the device can be unlocked.
User entry	A number from 0 to 9999
Factory setting	0

7.5 Resetting to factory settings (reset)

 By entering a certain code, you can completely or partially reset the entries for the parameters to the factory settings ¹⁾. Enter the code via the "Enter reset code" parameter (menu path: "Diagnosis" → "Enter reset code").

There are various reset codes for the device. The following table illustrates which parameters are reset by the particular reset codes. To perform a reset, operation must be unlocked (see "Locking/unlocking operation" section →  34).

Any customer-specific configuration carried out at the factory is not affected by a reset (customer-specific configuration remains). If you want to change the customer-specific configuration carried out at the factory, please contact Endress+Hauser Service. As there is no separate service level, the order code and serial number can be changed without a specific release code.

Reset code ¹⁾	Description and effect
62	PowerUp reset (warm start) <ul style="list-style-type: none"> ■ The device is restarted. ■ Data is read back anew from the EEPROM (process is reinitialized). ■ Any simulation which may be running is ended.
333	User reset <ul style="list-style-type: none"> ■ This code resets all the parameters apart from: <ul style="list-style-type: none"> - Device tag - Linearization table - Operating hours - Event logbook - Curr. trim 4 mA - Curr. trim 20 mA ■ Any simulation which may be running is ended. ■ The device is restarted.
7864	Total reset <ul style="list-style-type: none"> ■ This code resets all the parameters apart from: <ul style="list-style-type: none"> - Operating hours - Event logbook ■ Any simulation which may be running is ended. ■ The device is restarted.

1) To be entered in "System" → "Management" → "Enter reset code"

 After a "Total reset" in FieldCare you have to press the "refresh" button in order to ensure that the measuring units are also reset.

1) . The factory setting for the individual parameters is specified in the parameter description

8 Integrating device via HART® protocol

Version data for the device

Firmware version	01.00.zz	<ul style="list-style-type: none"> ▪ On the title page of the Operating instructions ▪ On nameplate ▪ Firmware Version parameter Diagnosis → Instrument info → Firmware version
Manufacturer ID	17 (0x11)	<ul style="list-style-type: none"> ▪ Manufacturer ID. parameter Diagnosis → Instrument info → Manufacturer ID
Device type code	36 (0x24)	<ul style="list-style-type: none"> ▪ Device type parameter Diagnosis → Instrument info → Device type
HART protocol revision	6.0	---
Device revision	1	<ul style="list-style-type: none"> ▪ On transmitter nameplate ▪ Device revision parameter Diagnosis → Instrument info → Device revision

The suitable device description file (DD) for the individual operating tools is listed in the table below, along with information on where the file can be acquired.

Operating tools

Operating tool	Reference sources for device descriptions (DD and DTM)
FieldCare	<ul style="list-style-type: none"> ▪ www.endress.com → Downloads area ▪ CD-ROM (contact Endress+Hauser) ▪ DVD (contact Endress+Hauser)
AMS Device Manager (Emerson Process Management)	www.endress.com → Downloads area
SIMATIC PDM (Siemens)	www.endress.com → Downloads area
Field Communicator 375, 475 (Emerson Process Management)	Use update function of handheld terminal

8.1 HART process variables and measured values

The following numbers are assigned to the process variables in the factory:

Process variable	Meas.	Level	
		Linear	Table active
First process variable (Primary variable)	0 (Pressure measured)	8 (Level before linearization)	9 (Tank content)
Second process variable (Secondary variable)	2 (Corrected press.)	0 (Pressure measured)	8 (Level before linearization)

Process variable	Meas.	Level	
		Linear	Table active
Third process variable (Tertiary variable)	3 (Sensor pressure)	2 (Corrected press.)	0 (Pressure measured)
Fourth process variable (Quaternary variable)	4 (Sensor temp.)		

 The assignment of the device variables to the process variable is displayed in the **Expert → Communication → HART output** menu.

The assignment of the device variables to the process variable can be changed using HART command 51.

An overview of the possible device variables can be found in the following section.

8.2 Device variables and measured values

The following measured values are assigned to the individual device variables:

Device variable code	Device variable	Measured value	
0	PRESSURE_1_FINAL_VALUE	Pressure measured	All
1	PRESSURE_1_AFTER_DAMPING	Press after damping	All
2	PRESSURE_1_AFTER_CALIBRATION	Corrected press.	All
3	PRESSURE_1_AFTER_SENSOR	Corrected press.	All
4	MEASURED_TEMPERATURE_1	Sensor temp.	All
8	MEASURED_LEVEL_AFTER_SIMULATION	Level before lin.	Only level
9	MEASURED_TANK_CONTENT_AFTER_SIMULATION	Tank content	Only level
10	CORRECTED_MEASUREMENT_DENSITY	Process density	Only level
12	HART_INPUT_VALUE	HART input val.	Cannot be selected as output
251	None (no device variable is mapped)	-	All (but only for quaternary variable)

 The device variables can be queried from a HART® master using HART® command 9 or 33.

9 Commissioning



NOTICE

If a pressure smaller than the minimum permitted pressure or greater than the maximum permitted pressure is present at the device, the following messages are output in succession:

- ▶ "S140 Working range P" or "F140 Working range P" (depending on the setting in the "Alarm behav. P" parameter)
- ▶ "S841 Sensor range" or "F841 Sensor range" (depending on the setting in the "Alarm behav. P" parameter)
- ▶ "S971 Adjustment" (depending on setting in "Alarm behav. P" parameter)

9.1 Post-installation check and function check

Before commissioning your measuring point, ensure that the post-installation and post-connection check have been performed.

- "Post-installation check" checklist →  21
- "Post-connection check" checklist →  31

9.2 Unlocking/locking configuration





If the device is locked to prevent configuration, it must first be unlocked.

9.2.1 Locking/unlocking software

If the device is locked via the software (device access code), the key symbol appears in the measured value display. If an attempt is made to write to a parameter, a prompt for the device access code appears. To unlock, enter the user-defined device access code.

9.3 Commissioning

Commissioning comprises the following steps:

- Function check →  38
- Selecting the language, measuring mode and pressure unit →  39
- Position adjustment →  40
- Configuring measurement:
 - Pressure measurement →  41
 - Level measurement →  43

9.4 Selecting the language

9.4.1 Configure language

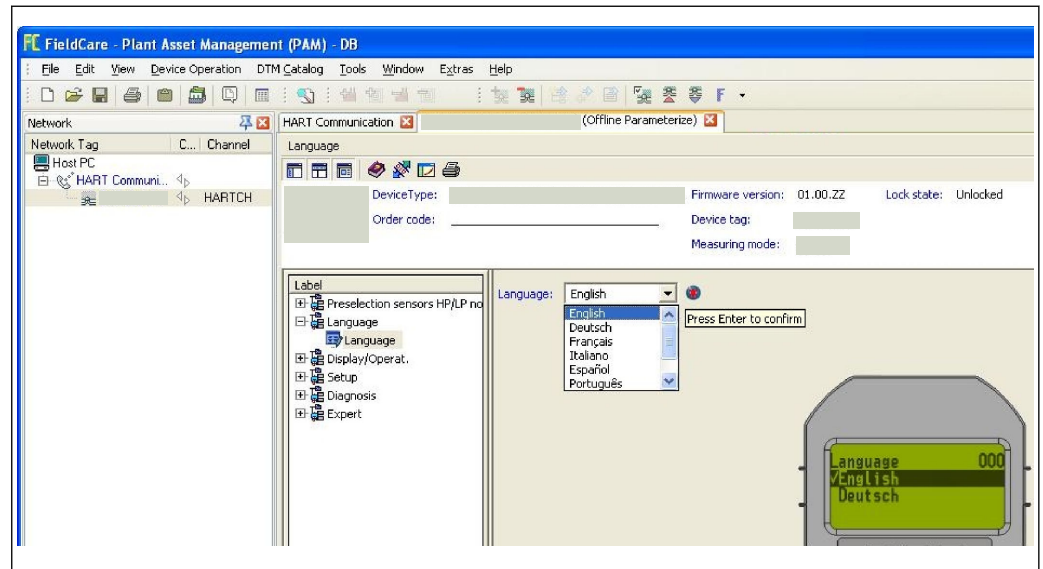

A0017654-EN

9.5 Measuring mode selection

i The device is configured for the "Pressure" measuring mode as standard. The measuring range and the unit in which the measured value is transmitted correspond to the data on the nameplate.



⚠ WARNING

Changing the measuring mode affects the span (URV)

This situation can result in product overflow.

- ▶ If the measuring mode is changed, the setting for the span (URV) must be checked in the "Setup" operating menu and readjusted if necessary.

Measuring mode

Navigation	  Setup → Measuring mode
Write permission	Operators/Service engineers/Expert
Description	Select the measuring mode. The operating menu is structured differently depending on the measuring mode selected.
Options	<ul style="list-style-type: none"> ■ Meas. ■ Level
Factory setting	Level

9.6 For selecting the pressure engineering unit

Press. eng. unit

Navigation	 Setup → Press. eng. unit
Write permission	Operators/Service engineers/Expert
Description	Select the pressure engineering unit. If a new pressure engineering unit is selected, all pressure-specific parameters are converted and displayed with the new unit.
Options	<ul style="list-style-type: none"> ■ mbar, bar ■ mmH2O, mH2O, inH2O ■ ftH2O ■ Pa, kPa, MPa ■ psi ■ mmHg, inHg ■ kgf/cm²
Factory setting	mbar or bar depending on the nominal measuring range of the sensor module, or as per order specifications



9.7 Position adjustment

The pressure resulting from the orientation of the device can be corrected here.

Pos. zero adjust (relative pressure sensor)

Navigation	 Setup → Pos. zero adjust
Write permission	Operators/Service engineers/Expert
Description	Position adjustment – the pressure difference between zero (set point) and the measured pressure need not be known.
Options	<ul style="list-style-type: none"> ■ Confirm ■ Cancel
Example	<ul style="list-style-type: none"> ■ Measured value = 2.2 mbar (0.033 psi) ■ You correct the measured value via the "Pos. zero adjust" parameter with the "Confirm" option. i.e. This means that you are assigning the value 0.0 to the pressure present. ■ Measured value (after pos. zero adjust) = 0.0 mbar ■ The current value is also corrected.
Factory setting	Cancel



Calib. offset (absolute pressure sensor)

Navigation	  Setup → Calib. offset
Write permission	Operators/Service engineers/Expert
Description	Position adjustment – the pressure difference between zero (set point) and the measured pressure must be known.
Options	<ul style="list-style-type: none"> ■ Confirm ■ Cancel
Example	<ul style="list-style-type: none"> ■ Measured value = 982.2 mbar (15 psi) ■ You correct the measured value via the "Calib. offset" parameter with the "Confirm" option. i.e. This means that you are assigning the value 980.0 to the pressure present. ■ Measured value (after position adjustment) = 980 mbar (15 psi) ■ The current value is also corrected.
Factory setting	Cancel

9.8 Configuring the damping

The pressure resulting from the orientation of the device can be corrected here.

Damping

Navigation	  Setup → Damping
Write permission	Operators/Service engineers/Expert (if the "Damping" DIP switch is set to "on")
Description	Enter damping time (time constant τ) ("Damping" DIP switch set to "on") Display damping time (time constant τ) ("Damping" DIP switch set to "off"). The damping affects the speed at which the measured value reacts to changes in pressure.
Input range	0.0 to 999.0 s
Factory setting	2.0 sec. or according to order specifications

9.9 Configuring pressure measurement

9.9.1 Calibration with reference pressure (wet calibration)

Example:

In this example, a device with a 400 mbar (6 psi) sensor module is configured for the 0 to +300 mbar (0 to 4.5 psi) measuring range i.e. 0 mbar is assigned to the 4 mA value and 300 mbar (4.5 psi) is assigned to the 20 mA value.

Prerequisite:

The pressure values 0 mbar and 300 mbar (4.5 psi) can be specified. For example, the device is already installed.

i Due to the orientation of the device, there may be pressure shifts in the measured value, i.e. the measured value is not zero in a pressureless condition. For information on how to perform a position adjustment, see → 40.

Description	
<p>1 Select the "Pressure" measuring mode via the "Measuring Mode" parameter. Menu path: Setup → Measuring mode</p> <p>⚠ WARNING</p> <p>Changing the measuring mode affects the span (URV) This situation can result in product overflow.</p> <ul style="list-style-type: none"> ▶ If the measuring mode is changed, the setting for the span (URV) must be checked in the "Setup" operating menu and readjusted if necessary. 	
<p>2 Select a pressure unit via the "Press. eng. unit" parameter, here "mbar" for example. Menu path: Setup → Press. eng. unit</p>	<p>A See table, step 3. B See table, step 4.</p>
<p>3 The pressure for the LRV (4 mA value) is present at the device, 0 mbar for example.</p> <p>Select the "Get LRV" parameter. Menu path: Setup → Extended setup → Current output → Get LRV</p> <p>Confirm the present value by selecting "Apply". The present pressure value is assigned to the lower current value (4 mA).</p>	<p>i Current value p Meas.</p>
<p>4 The pressure for the URV (20 mA value) is present at the device, 300 mbar (4.5 psi).</p> <p>Select the "Get URV" parameter. Menu path: Setup → Extended setup → Current output → Get URV</p> <p>Confirm the present value by selecting "Apply". The present pressure value is assigned to the upper current value (20 mA).</p>	
<p>5 Result: The measuring range is configured for 0 to +300 mbar (0 to 4.5 psi).</p>	

A0017671

9.9.2 Calibration without reference pressure (dry calibration)

Example:

In this example, a device with a 400 mbar (6 psi) sensor module is configured for the 0 to +300 mbar (0 to 4.5 psi) measuring range, i.e. 0 mbar is assigned to the 4 mA value and 300 mbar (4.5 psi) is assigned to the 20 mA value.

Prerequisite:

This is a theoretical calibration, i.e. the pressure values for the lower and upper range are known.

i Due to the orientation of the device, there may be pressure shifts in the measured value, i.e. the measured value is not zero in a pressureless condition. For information on how to perform a position adjustment, see → 40.

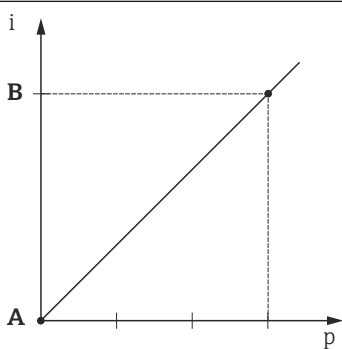
Description	
<p>1 Select the "Pressure" measuring mode via the "Measuring Mode" parameter. Menu path: Setup → Measuring mode</p> <p>⚠ WARNING Changing the measuring mode affects the span (URV) This situation can result in product overflow.</p> <ul style="list-style-type: none"> ▶ If the measuring mode is changed, the setting for the span (URV) must be checked in the "Setup" operating menu and readjusted if necessary. 	 <p>A <i>See table, step 3.</i> B <i>See table, step 4.</i> i <i>Current value</i> p <i>Meas.</i></p>
<p>2 Select a pressure unit via the "Press. eng. unit" parameter, here "mbar" for example. Menu path: Setup → Press. eng. unit</p>	
<p>3 Select the "Set LRV" parameter. Menu path: Setup → Extended setup → Current output → Set LRV</p> <p>Enter the value for the "Set LRV" parameter (here 0 mbar) and confirm. This pressure value is assigned to the lower current value (4 mA).</p>	
<p>4 Select the "Set URV" parameter. Menu path: Setup → Extended setup → Current output → Set URV</p> <p>Enter the value for the "Set URV" parameter, here 300 mbar (4.5 psi), and confirm. This pressure value is assigned to the upper current value (20 mA).</p>	
<p>5 Result: The measuring range is configured for 0 to +300 mbar (0 to 4.5 psi).</p>	

A0017671

9.10 Configuring level measurement

9.10.1 Information on level measurement

- i** You have a choice of two methods for calculating the level: "In pressure" and "In height". The table in the "Overview of level measurement" section that follows provides you with an overview of these two measuring tasks.
 - The limit values are not checked, i.e. the values entered must be appropriate for the sensor module and the measuring task for the device to be able to measure correctly.
 - Customer-specific units are not possible.
 - The values entered for "Empty calib./Full calib.", "Empty pressure/Full pressure", "Empty height/Full height" and "Set LRV/Set URV" must be at least 1% apart. The value will be rejected, and a warning message displayed, if the values are too close together.

9.10.2 Overview of level measurement

Measuring task	Level selection	Measured variable options	Description	Measured value display
Calibration is performed by entering two pressure-level value pairs.	"In pressure"	Via the "Output unit" parameter : %, level, volume or mass units	<ul style="list-style-type: none"> Calibration with reference pressure (wet calibration) → 46 Calibration without reference pressure (dry calibration) → 44 	The measured value display and the "Level before lin" parameter display the measured value.
Calibration is performed by entering the density and two height-level value pairs.	"In height"		<ul style="list-style-type: none"> Calibration with reference pressure (wet calibration) → 51 Calibration without reference pressure (dry calibration) → 48 	

9.10.3 "In pressure" level selection Calibration without reference pressure (dry calibration)

Example:

In this example, the volume in a tank should be measured in liters. The maximum volume of 1000 l (264 gal) corresponds to a pressure of 400 mbar (6 psi).

The minimum volume of 0 liters corresponds to a pressure of 0 mbar since the process isolating diaphragm of the probe is at the start of the level measuring range.

Prerequisite:

- The measured variable is in direct proportion to the pressure.
- This is a theoretical calibration i.e. the pressure and volume values for the lower and upper calibration point must be known.
- 
 - The values entered for "Empty calib./Full calib.", "Empty pressure/Full pressure" and "Set LRV/Set URV" must be at least 1% apart. The value will be rejected, and a warning message displayed, if the values are too close together. Further limit values are not checked, i.e. the values entered must be appropriate for the sensor module and the measuring task for the device to be able to measure correctly.
 - Due to the orientation of the device, there may be pressure shifts in the measured value, i.e. when the vessel is empty or partly filled, the measured value is not zero. For information on how to perform a position adjustment, see → 40.

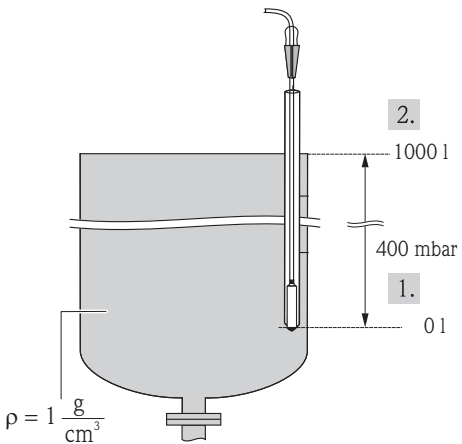
Description	
<p>1 Select the "Level" measuring mode via the "Measuring mode" parameter. Menu path: Setup → Measuring mode</p> <p>⚠ WARNING</p> <p>Changing the measuring mode affects the span (URV) This situation can result in product overflow.</p> <ul style="list-style-type: none"> ▶ If the measuring mode is changed, the setting for the span (URV) must be checked in the "Setup" operating menu and readjusted if necessary. 	
<p>2 Select a pressure unit via the "Press. eng. unit" parameter, here "mbar" for example. Menu path: Setup → Press. eng. unit</p>	

Description	
3	Select the "In pressure" level mode via the "Level selection" parameter. Menu path: Setup → Extended setup → Level → Level selection.
4	Select a volume unit via the "Unit before lin." parameter, here "l" (liter) for example. Menu path: Setup → Extended setup → Level → Unit before lin.
5	Select the "Dry" option via the "Calibration mode" parameter. Menu path: Setup → Extended setup → Level → Calibration mode
6	Enter the volume value for the lower calibration point via the "Empty calib." parameter, here 0 liters for example. Menu path: Setup → Extended setup → Level → Empty calib.
7	Enter the pressure value for the lower calibration point via the "Empty pressure" parameter, here "0 mbar" for example. Menu path: Setup → Extended setup → Level → Empty pressure
8	Enter the volume value for the upper calibration point via the "Full calib." parameter, here 1000 l (264 gal). Menu path: Setup → Extended setup → Level → Full calib.
9	Enter the pressure value for the upper calibration point via the "Full pressure" parameter, here 400 mbar (6 psi). Menu path: Setup → Extended setup → Level → Full pressure
10	"Adjust density" contains the factory setting 1.0 but can be changed if required. The value pairs subsequently entered must correspond to this density. Menu path: Setup → Extended setup → Level → Adjust density
11	Set the volume value for the lower current value (4 mA) via the "Set LRV" parameter (0 l). Menu path: Setup → Extended setup → Current output → Set LRV
12	Set the volume value for the upper current value (20 mA) via the "Set URV" parameter (1000 l (264 gal)). Menu path: Setup → Extended setup → Current output → Set URV
13	If the process uses a medium other than that on which the calibration was based, the new density must be specified in the "Process density" parameter. Menu path: Setup → Extended setup → Current output → Process density.

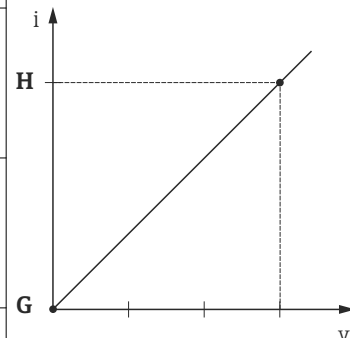
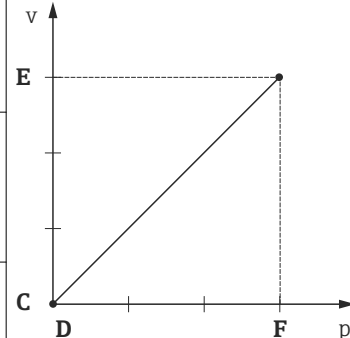

- C See table, step 6.
- D See table, step 7.
- E See table, step 8.
- F See table, step 9.
- G See table, step 11
- H See table, step 12
- i Current value
- p Meas.
- v Volume

A0017662

Description	
14	If density correction is required, assign the temperature probe in the "Auto dens. corr." parameter. A density correction is only possible for water. A temperature-density curve that is saved in the device is used. For this reason, the "Adjust density" (step 10) and "Process density" (step 13) parameters are not used here. Menu path: Expert → Application → Level → Auto dens. corr.
15	Result: The measuring range is configured for 0 to 1000 l (0 to 264 gal).

i For this level mode, the measured variables %, level, volume and mass are available, see "Unit before lin." .

9.10.4 "In pressure" level selection Calibration with reference pressure (wet calibration)

Example:

In this example, the level in a tank should be measured in "m". The maximum level is 3 m (9.8 ft).

The pressure range is derived from the level and the density of the medium. In this situation, the device sets the pressure range to 0 to +300 mbar (0 to 4.5 psi).

Prerequisite:

- The measured variable is in direct proportion to the pressure.
- The tank can be filled and emptied.

i The values entered for "Empty calib./Full calib." and "Set LRV/Set URV" and the pressures present must be at least 1% apart. The value will be rejected, and a warning message displayed, if the values are too close together. Other limit values are not checked, i.e. the values entered must be appropriate for the sensor and the measuring task for the device to be able to measure correctly.

Description	
1	Perform a "position adjustment" → 40.
2	Select the "Level" measuring mode via the "Measuring mode" parameter. Menu path: Setup → Measuring mode ⚠ WARNING Changing the measuring mode affects the span (URV) This situation can result in product overflow. ► If the measuring mode is changed, the setting for the span (URV) must be checked in the "Setup" operating menu and readjusted if necessary.
3	Select a pressure unit via the "Press. eng. unit" parameter, here "mbar" for example. Menu path: Setup → Press. eng. unit
4	Select the "In pressure" level mode via the "Level selection" parameter. Menu path: Setup → Extended setup → Level → Level selection.

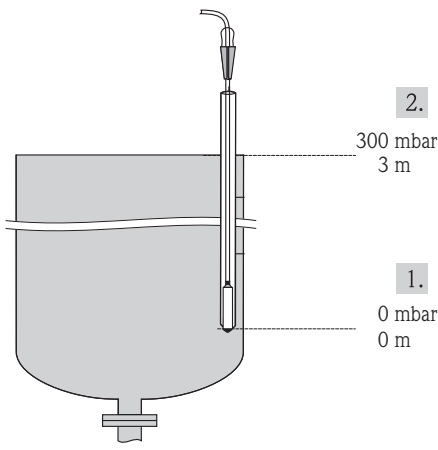

1 See table, step 9.

2 See table, step 10.

Description	
5	<p>If density correction is required, assign the temperature probe in the "Auto dens. corr." parameter. Menu path: Expertc → Application → Auto dens. corr. A density correction is only possible for water. A temperature-density curve that is saved in the device is used. For this reason, the "Adjust density" (step 8) and "Process density" (step 13) parameters are not used here.</p>
6	<p>Select a level unit via the "Output unit" parameter, "m" for example. Menu path: Setup → Extended setup → Level → Output unit</p>
7	<p>Select the "Wet" option via the "Calibration mode" parameter. Menu path: Setup → Extended setup → Level → Calibration mode</p>
8	<p>If the calibration is performed with a medium other than the process medium, enter the density of the calibration medium in the "Adjust density" parameter. Menu path: Setup → Extended setup → Level → Adjust density</p> <p> The process density can be changed only if automatic density correction is switched off (see step 5).</p>
9	<p>The hydrostatic pressure for the lower calibration point is present at the device, here "0 mbar" for example.</p> <p>Select the "Empty calib." parameter. Menu path: Setup → Extended setup → Level → Empty calib.</p> <p>Enter the level value, here 0 m for example. The pressure value present is assigned to the lower level value by confirming the value.</p>
10	<p>The hydrostatic pressure for the upper calibration point is present at the device, here 300 mbar (4.35 psi) for example.</p> <p>Select the "Full calib." parameter. Menu path: Setup → Extended setup → Level → Full calib.</p> <p>Enter the level value, 3 m (9.8 ft). The pressure value present is assigned to the upper level value by confirming the value.</p>
11	<p>Use the "Set LRV" parameter to set the level value for the lower current value (4 mA), here "0 m" for example. Menu path: Setup → Extended setup → Current output → Set LRV</p>
12	<p>Use the "Set URV" parameter to set the upper current value (20 mA) (3 m (9.8 ft)). Menu path: Setup → Extended setup → Current output → Set URV</p>

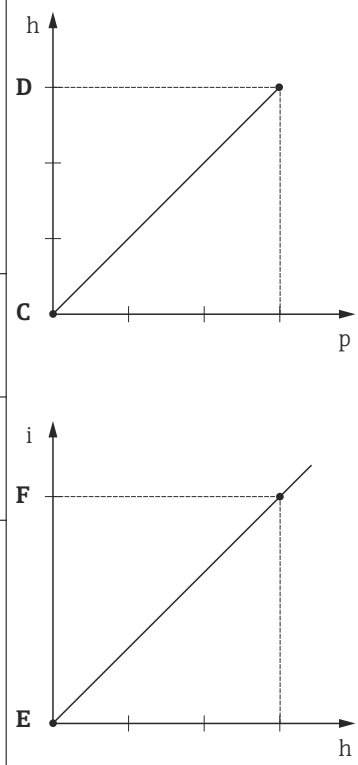

C See table, step 9.
 D See table, step 10.
 E See table, step 11.
 F See table, step 12.
 h Height
 i Current value
 p Meas.

A0017658

Description	
12	<p>If the process uses a medium other than that on which the calibration was based, the new density must be specified in the "Process density" parameter. Menu path: Setup → Extended setup → Level → Process density.</p> <p>i The process density can be changed only if automatic density correction is switched off (see step 5).</p>
13	<p>Result: The measuring range is configured for 0 to 3 m (0 to 9.8 ft).</p>

i For this level mode, the measured variables %, level, volume and mass are available, see "Unit before lin." .

9.10.5 "In height" level selection Calibration without reference pressure (dry calibration)

Example:

In this example, the volume in a tank should be measured in liters. The maximum volume of 1000 l (264 gal) corresponds to a level of 4 m (13 ft). The minimum volume of 0 liter corresponds to a level of 0 m since the process isolating diaphragm of the probe is at the start of the level measuring range.

Prerequisite:

- The measured variable is in direct proportion to the pressure.
 - This is a theoretical calibration i.e. the height and volume values for the lower and upper calibration point must be known.
- i**
- The values entered for "Empty calib./Full calib.", "Empty height/Full height" and "Set LRV/Set URV" must be at least 1% apart. The value will be rejected, and a warning message displayed, if the values are too close together. Other limit values are not checked, i.e. the values entered must be appropriate for the sensor and the measuring task for the device to be able to measure correctly.
 - Due to the orientation of the device, there may be pressure shifts in the measured value, i.e. when the vessel is empty or partly filled, the measured value is not zero. For information on how to perform a position adjustment, see → 40.

Description	
1	<p>Select the "Level" measuring mode via the "Measuring mode" parameter. Menu path: Setup → Measuring mode</p> <p>⚠ WARNING Changing the measuring mode affects the span (URV) This situation can result in product overflow. ► If the measuring mode is changed, the setting for the span (URV) must be checked in the "Setup" operating menu and readjusted if necessary.</p>
2	<p>Select a pressure unit via the "Press. eng. unit" parameter, here "mbar" for example. Menu path: Setup → Press. eng. unit</p>

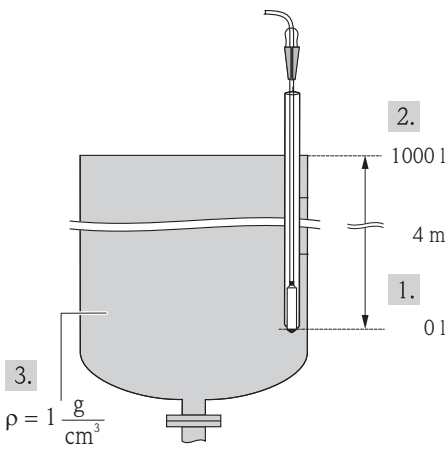

2. 1000 l

4 m

1. 0 l

3. $\rho = 1 \frac{\text{g}}{\text{cm}^3}$

A001882.7

	Description	
3	Select the "In height" level mode via the "Level selection" parameter. Menu path: Setup → Extended setup → Level → Level selection.	1 See table, steps 10 and 11. 2 See table, steps 13 and 14. 3 See table, step 12
4	If density correction is required, assign the temperature probe in the "Auto dens. corr." parameter. Menu path: Setup → Extended setup → Level → Level selection.	
4	Select a volume unit via the "Unit before lin." parameter, here "l" (liter) for example. Menu path: Setup → Extended setup → Level → Unit before lin. A density correction is only possible for water. A temperature-density curve that is saved in the device is used. For this reason, the "Adjust density" (step 12) and "Process density" (step 15) parameters are not used here.	
5	Select a volume unit via the "Output unit" parameter, here "l" (liter) for example. Menu path: Setup → Extended setup → Level → Output unit	
6	Select a level unit via the "Height unit" parameter, "m" for example. Menu path: Setup → Extended setup → Level → Height unit	

Description	
7	Select the "Dry" option via the "Calibration mode" parameter. Menu path: Setup → Extended setup → Level → Calibration mode
8	Enter the volume value for the lower calibration point via the "Empty calib." parameter, here 0 liters for example. Menu path: Setup → Extended setup → Level → Empty calib.
9	Enter the height value for the lower calibration point via the "Empty height" parameter, here 0 m for example. Menu path: Setup → Extended setup → Level → Empty height
10	Enter the volume value for the upper calibration point via the "Full calib." parameter, here 1 000 l (264 gal) for example. Menu path: Setup → Extended setup → Level → Full calib.
11	Enter the height value for the upper calibration point via the "Full height" parameter, here 4 m (13 ft) for example. Menu path: Setup → Extended setup → Level → Full height
12	Enter the density of the medium via the "Adjust density" parameter, here "1 g/cm ³ " (1 SGU) for example. Menu path: Setup → Extended setup → Level → Adjust density
13	Set the volume value for the lower current value (4 mA) via the "Set LRV" parameter (0 l). Menu path: Setup → Extended setup → Current output → Set LRV
14	Set the volume value for the upper current value (20 mA) via the "Set URV" parameter (1 000 l (264 gal)). Menu path: Setup → Extended setup → Current output → Set URV
15	If the process uses a medium other than that on which the calibration was based, the new density must be specified in the "Process density" parameter. Menu path: Setup → Extended setup → Current output → Process density. i The process density can only be changed if automatic density correction is switched off (see Step 4).
16	Result: The measuring range is configured for 0 to 1 000 l (0 to 264 gal).

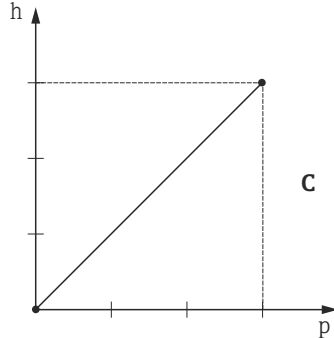
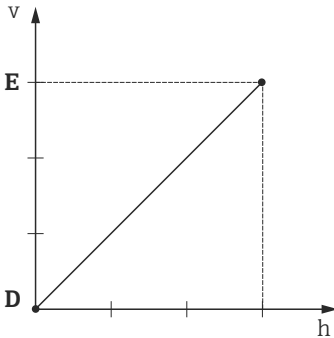
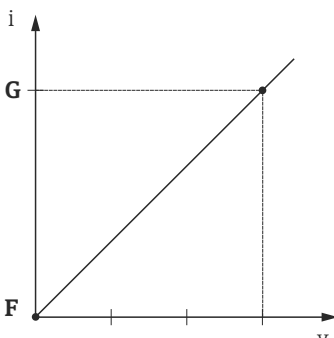
C See table, step 12.
 D See table, step 8.
 E See table, step 10.
 F See table, step 13.
 G See table, step 14.
 h Height
 i Current value
 p Meas.
 v Volume

A0017666

i For this level mode, the measured variables %, level, volume and mass are available, see "Unit before lin." .

9.10.6 "In height" level selection Calibration with reference pressure (wet calibration)

Example:

In this example, the volume in a tank should be measured in liters. The maximum volume of 1 000 l (264 gal) corresponds to a level of 4 m (13 ft).

The minimum volume of 0 liter corresponds to a level of 0 m since the process isolating diaphragm of the probe is at the start of the level measuring range. The density of the fluid is 1 g/cm³ (1 SGU).

Prerequisite:

- The measured variable is in direct proportion to the pressure.
- The tank can be filled and emptied.

i The values entered for "Empty calib./Full calib." and "Set LRV/Set URV" and the pressures present must be at least 1% apart. The value will be rejected, and a warning message displayed, if the values are too close together. Other limit values are not checked, i.e. the values entered must be appropriate for the sensor and the measuring task for the device to be able to measure correctly.

Description	
1	Perform a "position adjustment" → 40.
2	Select the "Level" measuring mode via the "Measuring mode" parameter. Menu path: Setup → Measuring mode <div style="border: 1px solid black; padding: 2px; width: fit-content;"> ⚠ WARNING </div> Changing the measuring mode affects the span (URV) This situation can result in product overflow. ► If the measuring mode is changed, the setting for the span (URV) must be checked in the "Setup" operating menu and readjusted if necessary.
3	Select the "In height" level mode via the "Level selection" parameter. Menu path: Setup → Extended setup → Level → Level selection.
4	If density correction is required, assign the temperature probe in the "Auto dens. corr." parameter. Menu path: Expertc → Application → Auto dens. corr. A density correction is only possible for water. A temperature-density curve that is saved in the device is used. For this reason, the "Adjust density" (step 11) and "Process density" (step 14) parameters are not used here.
5	Select a pressure unit via the "Press. eng. unit" parameter, here "mbar" for example. Menu path: Setup → Press. eng. unit

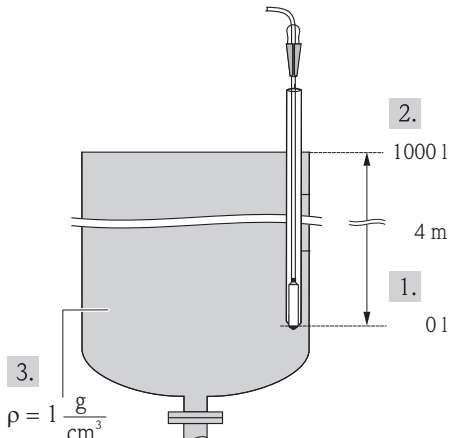

1 See table, step 9.

2 See table, step 10.

3 See table, step 11.

A0018827

	Description	
6	Select a volume unit via the "Output unit" parameter, here "l" (liter) for example. Menu path: Setup → Extended setup → Level → Output unit	
7	Select a height unit via the "Height unit" parameter, here "m" for example. Menu path: Setup → Extended setup → Level → Height unit	
8	Select the "Wet" option via the "Calibration mode" parameter. Menu path: Setup → Extended setup → Level → Calibration mode	
9	The hydrostatic pressure for the lower calibration point is present at the device, here "0 mbar" for example. Enter the volume value for the lower calibration point via the "Empty calib." parameter, here "0 liter" for example. Menu path: Setup → Extended setup → Level → Empty calib.	
10	The hydrostatic pressure for the upper calibration point is present at the device, here "400 mbar (6 psi)" for example. Enter the volume value for the upper calibration point via the "Full calib." parameter, here 1 000 l (264 gal) for example. Menu path: Setup → Extended setup → Level → Full calib.	
11	If the calibration is performed with a medium other than the process medium, enter the density of the calibration medium in the "Adjust density" parameter, here 1 g/cm ³ (1 SGU) for example. Menu path: Setup → Extended setup → Level → Adjust density The process density can only be changed if automatic density correction is switched off (see Step 4).	
12	Set the volume value for the lower current value (4 mA) via the "Set LRV" parameter (0 l). Menu path: Setup → Extended setup → Current output → Set LRV	
13	Set the volume value for the upper current value (20 mA) via the "Set URV" parameter (1 000 l (264 gal)). Menu path: Setup → Extended setup → Current output → Set URV	
14	If the process uses a medium other than that on which the calibration was based, the new density must be specified in the "Process density" parameter. Menu path: Setup → Extended setup → Level → Process density. The process density can only be changed if automatic density correction is switched off (see Step 4).	
15	Result: The measuring range is configured for 0 to 1 000 l (0 to 264 gal).	

C See table, step 10.
D See table, step 8.
E See table, step 9.
F See table, step 11.
G See table, step 12.
h Height
i Current value
p Meas.
v Volume

A0017666

i The measured variables %, level, volume and mass are available for this level mode, see "Output unit".

9.10.7 Calibration with partially filled vessel (wet calibration)

Example:

This example explains a wet calibration for cases in which it is not possible to empty the vessel and then fill it to 100%.

During this wet calibration, a level of 20% is used as the calibration point for "Empty" and a level of "25%" is used as the calibration point for "Full".

The calibration is then extended to 0% to 100% and lower range-value (LRV)/upper range-value (URV) are adapted accordingly.

Prerequisite:

- The default value in level mode for the calibration mode is "Wet".
- This value can be adjusted: Menu path: Setup → Extended setup → Level → Calibration mode

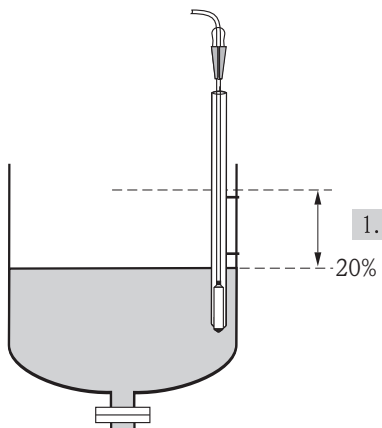
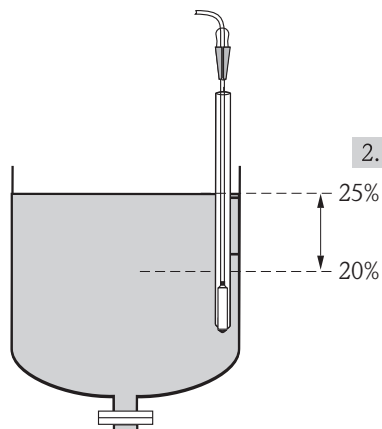
Description	
<p>1 Select the "Level" measuring mode via the "Measuring mode" parameter. Menu path: Setup → Measuring mode</p> <p>⚠ WARNING Changing the measuring mode affects the span (URV) This situation can result in product overflow. ▶ If the measuring mode is changed, the setting for the span (URV) must be checked in the "Setup" operating menu and readjusted if necessary.</p>	
<p>2 Set the value for "Empty calib." with the acting pressure for the level, e.g. 20 % Menu path: Setup → Extended setup → Level → Empty calib.</p>	

1 See table, step 2
 2 See table, step 3

A0018841

	Description
3	Set the value for "Full calib." with the acting pressure for the level, e.g. 25 %. Menu path: Setup → Extended setup → Level → Full calib.
4	The values for the pressure when the vessel is full or empty are measured automatically during adjustment. The transmitter automatically sets the pressure values that are most suitable for "Empty calib." and "Full calib." as the minimum and maximum pressure which generates the output current. For this reason, the correct upper-range value (URV) and the correct lower-range value (LRV) must be set.

-  **If the process uses a medium other than that on which the calibration was based, the new density must be specified in the "Process density" parameter. In this case, you have to enter the various densities via the following menu path:**
- Setup → Extended setup → Level → Adjust density (034) e.g. 1.0 kg/l for water)
 - Setup → Extended setup → Level → Process density (035) e.g. 0.8 kg/l for oil)

9.10.8 Level measurement with absolute pressure probe and external pressure signal (electrical differential pressure)

Example:

In this example, a Waterpilot FMX21 and a Cerabar M device (each with an absolute pressure measuring cell) are connected via the common communication bus. The level can thus be measured in a deep well, with simultaneous compensation for the effect of atmospheric pressure.

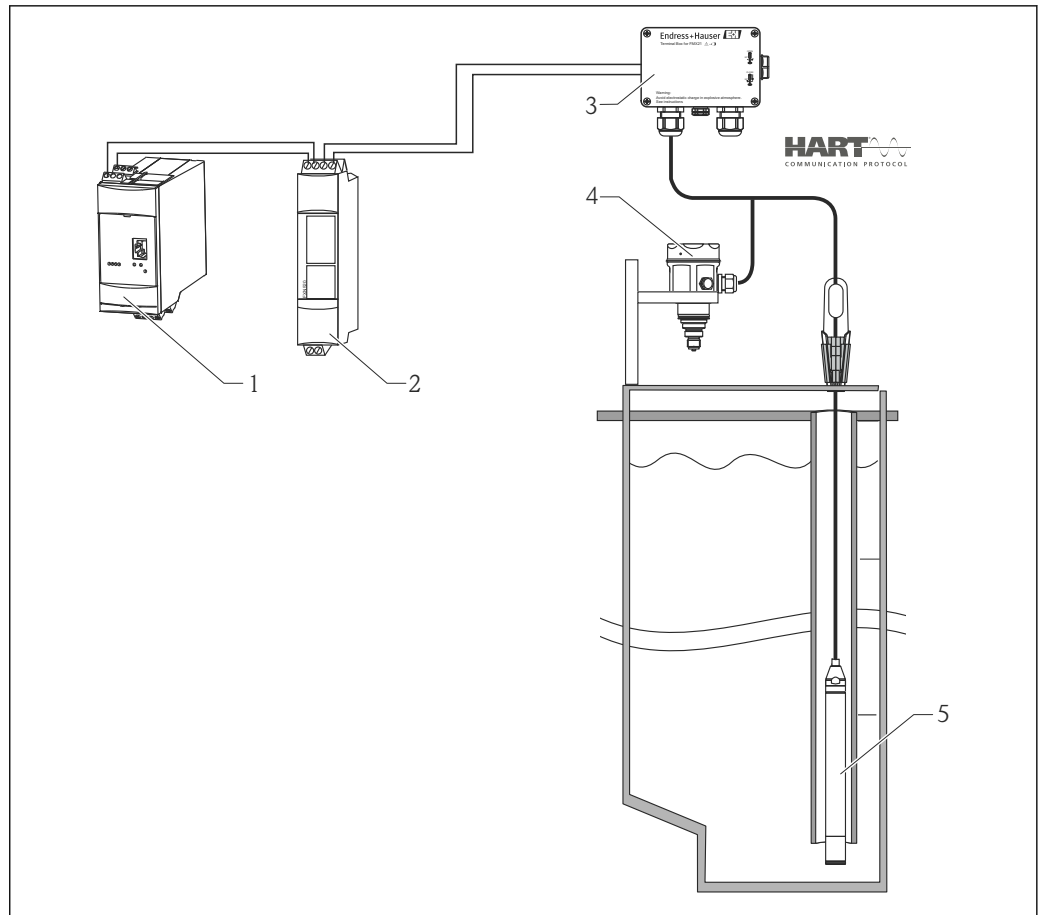

A0018821

- 1 Fieldgate FXA520
- 2 Multidrop connector FXN520
- 3 Terminal box (can be ordered as an accessory)
- 4 Cerabar M absolute pressure (atmospheric pressure)
- 5 Waterpilot absolute pressure (level)

Adjustment of the level sensor (Waterpilot)	
1	Select the "Level" measuring mode via the "Measuring mode" parameter. Menu path: Setup → Measuring mode ⚠ WARNING Changing the measuring mode affects the span (URV) This situation can result in product overflow. ► If the measuring mode is changed, the setting for the span (URV) must be checked in the "Setup" operating menu and readjusted if necessary.
2	Select a pressure unit via the "Press. eng. unit" parameter, here "mbar" for example. Menu path: Setup → Press. eng. unit
3	The sensor is unpressurized, perform a position adjustment → 40
4	Switch on burst mode via the "Burst mode" parameter. Menu path: Expert → Communication → HART config
5	Set the output current to "Fixed" 4.0 mA via the "Current Mode" parameter. Menu path: Expert → Communication → HART config
6	Configure an address ≠0 using the "Bus address" parameter, e.g. bus address = 1. (HART 5.0 master: Range 0 to 15, where address = 0 calls up the "Signaling" setting; HART 6.0 master: Range 0 to 63) Menu path: Expert → Communication → HART config

Adjustment of the level sensor (Waterpilot)	
1	Select the "Level" measuring mode via the "Measuring mode" parameter. Menu path: Setup → Measuring mode ⚠ WARNING Changing the measuring mode affects the span (URV) This situation can result in product overflow. ▶ If the measuring mode is changed, the setting for the span (URV) must be checked in the "Setup" operating menu and readjusted if necessary.
2	Select a pressure unit via the "Press. eng. unit" parameter, here "mbar" for example. Menu path: Setup → Press. eng. unit
3	The sensor is unpressurized, perform a position adjustment →  40
4	Set the output current to "Fixed" 4.0 mA via the "Current Mode" parameter. Menu path: Expert → Communication → HART config
5	Configure an address ≠ 0 using the "Bus address" parameter, e.g. bus address = 2. (HART 5.0 master: Range 0 to 15, where address = 0 calls up the "Signaling" setting; HART 6.0 master: Range 0 to 63) Menu path: Expert → Communication → HART config
6	Activate the reading of a value sent externally in burst mode via the "Electr. delta P" parameter. Menu path: Expert → Application
7	Perform level adjustment (wet or dry)
8	Result: The measured value output by the atmospheric pressure sensor equals the level in the deep well (differential signal) and can be read out by means of a HART request for the address of the atmospheric pressure sensor.

- It is not permissible to reverse the assignment of the measuring points to the direction of communication.
- The measured value of the transmitting device (via burst) must always be greater than the measured value of the receiving device (via "Electr. Delta P" mode).
- Adjustments that result in an offset of the pressure values (e.g. position adjustment, trim) must always be performed in accordance with the individual sensor and its orientation and independently of the "Electr. Delta P" application.
- Other settings result in non-permitted use of the "Electr. Delta P" mode and can lead to incorrect measured values.

9.11 Automatic density compensation

9.11.1 Automatic density compensation with the internally measured sensor temperature

Example:

In this example, a Waterpilot FMX21 is used for level measurement in water. The change in the water density caused by changing temperatures is automatically factored into the level signal by activating the automatic density compensation.

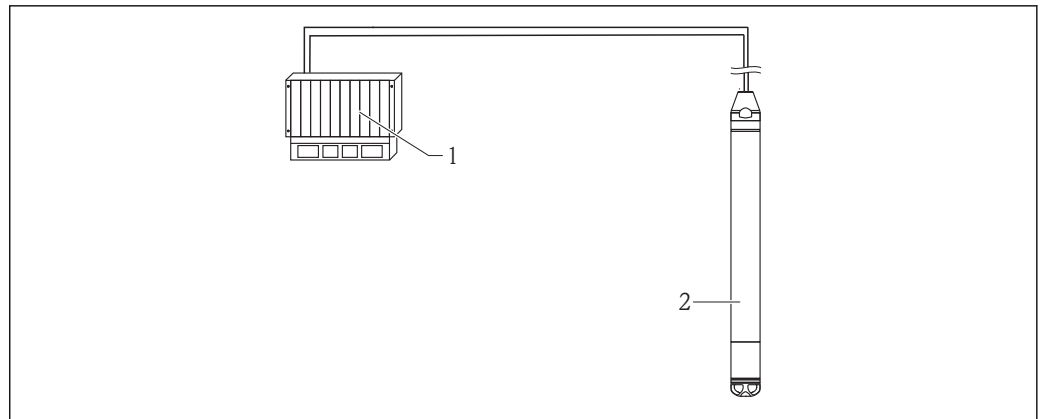

A0018822

- 1 HART master, e.g. PLC (programmable logic controller)
- 2 Waterpilot FMX21

Adjustment of the Waterpilot for level measurement	
1	<p>Select the "Level" measuring mode via the "Measuring mode" parameter. Menu path: Setup → Measuring mode</p> <p>⚠ WARNING</p> <p>Changing the measuring mode affects the span (URV) This situation can result in product overflow.</p> <ul style="list-style-type: none"> ▶ If the measuring mode is changed, the setting for the span (URV) must be checked in the "Setup" operating menu and readjusted if necessary.
2	<p>Select a pressure unit via the "Press. eng. unit" parameter, here "mbar" for example. Menu path: Setup → Press. eng. unit</p>
3	<p>The sensor is unpressurized, perform a position adjustment → 🗨 40</p>
4	<p>Set the "Auto dens. corr." parameter to Sensor temperature. Menu path: Expert → Application</p>
5	<p>Perform level adjustment (wet or dry)</p>
6	<p>Result: The measured value output by the Waterpilot corresponds to the level in the deep well corrected by means of the density characteristic line of the water.</p>

9.11.2 Automatic density compensation using an integrated Pt100 for calculation in a suitable HART master (e.g. PLC)

Example:

In this example, the FMX21 with an integrated Pt100 is connected via the common communication bus to any temperature head transmitter with HART communication (e.g. TMT182). The temperature and pressure signal are transmitted to the HART master (e.g. PLC), where a corrected level value can be generated using a stored linearization table or density function (of a chosen medium). A pressure signal and a temperature signal can thus be generated with a chosen density function to compensate for a level.

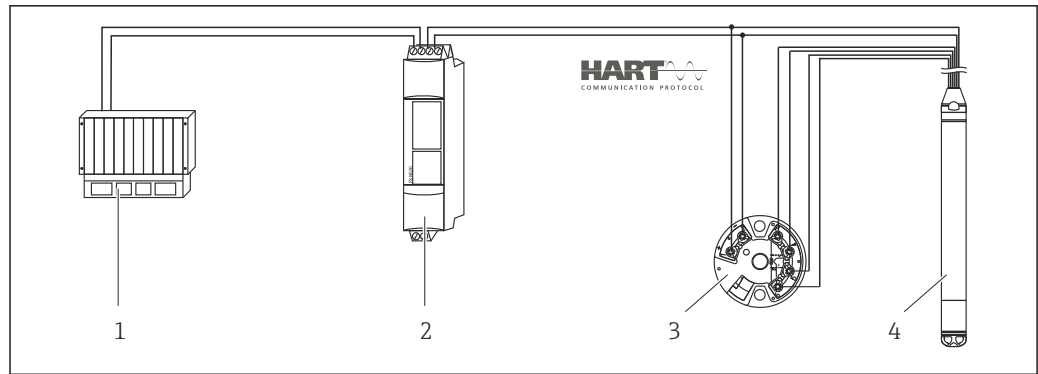

- 1 HART master, PLC (programmable logic controller)
- 2 Multidrop connector FXN520
- 3 Temperature head transmitter TMT182
- 4 Waterpilot FMX21

Adjustment of the Waterpilot for level measurement	
1	<p>Select the "Level" measuring mode via the "Measuring mode" parameter. Menu path: Setup → Measuring mode</p> <p>⚠ WARNING</p> <p>Changing the measuring mode affects the span (URV) This situation can result in product overflow.</p> <ul style="list-style-type: none"> ▶ If the measuring mode is changed, the setting for the span (URV) must be checked in the "Setup" operating menu and readjusted if necessary.
2	<p>Select a pressure unit via the "Press. eng. unit" parameter, here "mbar" for example. Menu path: Setup → Press. eng. unit</p>
3	<p>The sensor is unpressurized, perform a position adjustment → 40</p>
4	<p>Set the output current to "Fixed" 4.0 mA via the "Current Mode" parameter. Menu path: Expert → Communication → HART config</p>
5	<p>Perform level adjustment (wet or dry)</p>
6	<p>Configure an address ≠ 0 using the "Bus address" parameter, e.g. bus address = 1. (HART 5.0 master: Range 0 to 15, where address = 0 calls up the "Signaling" setting; HART 6.0 master: Range 0 to 63) Menu path: Expert → Communication → HART config</p> <p>i The output current of the temperature head transmitter used must also be set to "Fixed" and have a HART address other than zero (e.g. address = 2).</p>
7	<p>Result: By calculating the pressure signal and temperature signal in a suitable HART master (e.g. PLC), a corrected level value can be determined for a chosen medium using a suitable density function.</p>

9.11.3 Automatic density compensation using an external temperature signal for calculation in the FMX21

Example:

In this example, the FMX21 with an integrated Pt100 is connected to a HART-compliant temperature head transmitter via the common communication bus. In this case, the signal of the Pt100 is analyzed using a HART-compliant (min. HART 5.0) temperature head transmitter that supports burst mode. The change in the water density caused by changing temperatures is automatically factored into the level signal by activating the automatic density compensation.

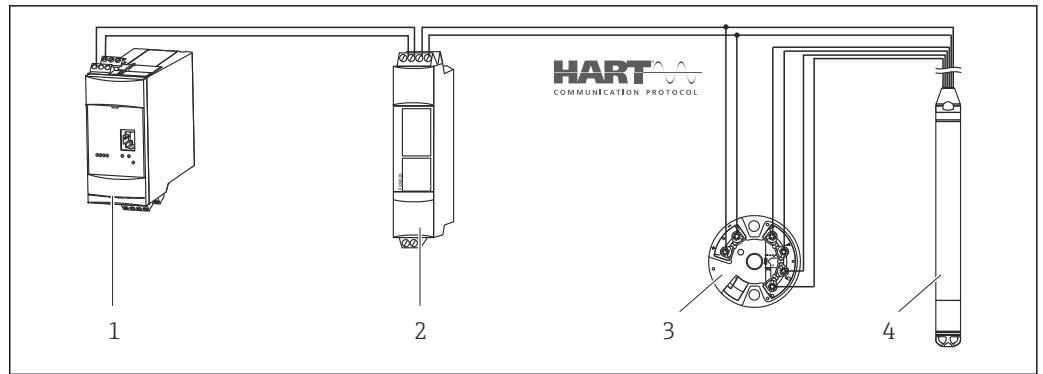

A0018764

- 1 Fieldgate FXA520
- 2 Multidrop connector FXN520
- 3 Temperature head transmitter TMT182 (burst mode)
- 4 Waterpilot FMX21

Configuring the HART-compliant temperature head transmitter (min. HART 5.0) with burst function	
	The output current of the temperature head transmitter used should be set to "Fixed" and must have a HART address other than zero (e.g. address = 1). The burst function must then be switched on with HART command 1. This step should be performed before the procedure described below in order to avoid a HART input error of the FMX21 being output during commissioning.
1	Select the "Level" measuring mode via the "Measuring mode" parameter. Menu path: Setup → Measuring mode ⚠ WARNING Changing the measuring mode affects the span (URV) This situation can result in product overflow. ▶ If the measuring mode is changed, the setting for the span (URV) must be checked in the "Setup" operating menu and readjusted if necessary.
2	Select a pressure unit via the "Press. eng. unit" parameter, here "mbar" for example. Menu path: Setup → Press. eng. unit
3	The sensor is unpressurized, perform a position adjustment → 📄 40
4	Set the "Auto dens. corr." parameter to "External value". Menu path: Expert → Application
5	Perform level adjustment (wet or dry) Result: The measured value output by the Waterpilot equals the level in the deep well corrected by means of the density characteristic line of the water.

i The TMT182 temperature head transmitter is not suitable for this configuration.

9.12 Linearization

9.12.1 Semi-automatic entry of a linearization table

Example:

In this example, the volume in a tank with a conical outlet should be measured in m³.

Prerequisite:

- The tank can be filled or emptied. The linearization characteristic must rise or fall continuously.
- The "Level" measuring mode has been selected.
- A level calibration has been performed.
- For a description of the parameters mentioned, see the "Description of device parameters" section .

⚠ WARNING

Changing the measuring mode affects the span (URV)

This situation can result in product overflow.

- ▶ If the measuring mode is changed, the setting for the span (URV) must be checked in the "Setup" operating menu and readjusted if necessary.

Description	
1	Select the "Semiautom. entry" option via the "Lin. mode" parameter. Menu path: Setup → Extended setup → Linearization → Lin. mode
2	Select using the "Unit after lin." e.g. m ³ . Menu path: Setup → Extended setup → Linearization → Unit after lin.
3	Fill the tank to the height of the 1st point.
4	Enter the number of the point in the table using the "Line-numb" parameter e.g. 1. Menu path: Setup → Extended setup → Linearization → Line numb The current level is displayed via the "X-value" parameter. Menu path: Setup → Extended setup → Linearization → X-val Enter the associated volume value via the "Y-val" parameter, here 0 m ³ for example, and confirm value. Menu path: Setup → Extended setup → Linearization → Y-val
5	To enter another point in the table, continue filling the tank and select the "Next point" option via the "Edit table" parameter. Enter the next point as explained in Step 4. Menu path: Setup → Extended setup → Linearization → Edit table

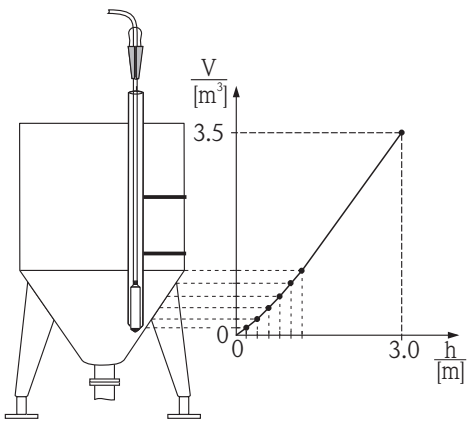

A0018843

h Height
v Volume

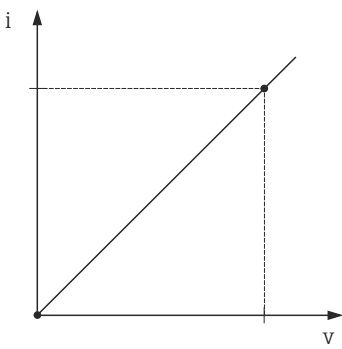
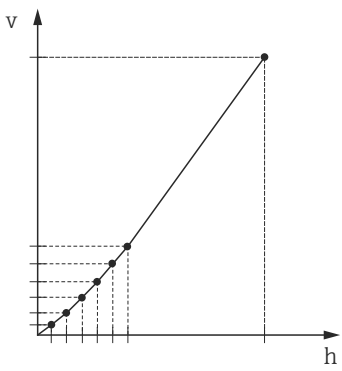

A0017670

Description	
6	Once all the points have been entered in the table, select the "Activate table" option via the "Lin. mode" parameter. Menu path: Setup → Extended setup → Linearization → Lin. mode
7	Result: Result: The measured value after linearization is displayed.

-  Error message F510 "Linearization" and alarm current as long as the table is being entered and until the table is activated.
- The lower-range value (= 4mA) is defined by the smallest point in the table.
The upper-range value (= 20mA) is defined by the largest point in the table.
- Using the parameters "Set LRV" and "Set URV", you can change the allocation of the volume/mass values to the current values.

9.12.2 Manual entry of a linearization table

Example:

In this example, the volume in a tank with a conical outlet should be measured in m³.

Prerequisite:

- This is a theoretical calibration, i.e. the points for the linearization table are known.
- The "Level" measuring mode has been selected.
- A level calibration has been performed.
- The linearization characteristic must rise or fall continuously.
- For a description of the parameters mentioned, see the "Description of device parameters" section .

⚠ WARNING

Changing the measuring mode affects the span (URV)

This situation can result in product overflow.

- ▶ If the measuring mode is changed, the setting for the span (URV) must be checked in the "Setup" operating menu and readjusted if necessary.

Description	
1	Select the "Manual entry" option via the "Lin. mode" parameter. Menu path: Setup → Extended setup → Linearization → Lin. mode
2	Select using the "Unit after lin." e.g. m ³ . Menu path: Setup → Extended setup → Linearization → Unit after lin.

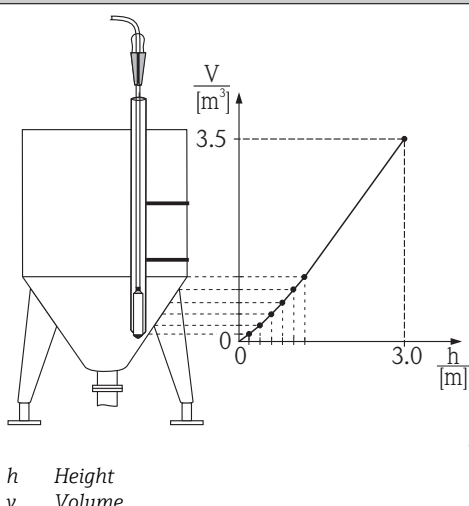



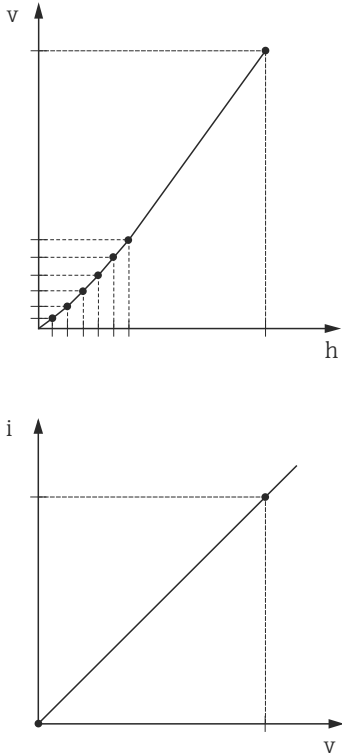

Description	
3	<p>Enter the number of the point in the table using the "Line-numb" parameter e.g. 1. Menu path: Setup → Extended setup → Linearization → Line numb</p> <p>The level is entered via the "X-val" parameter, here 0 m for example. Confirm your entry. Menu path: Setup → Extended setup → Linearization → X-val</p> <p>Enter the associated volume value via the "Y-val" parameter, here 0 m³ for example, and confirm value. Menu path: Setup → Extended setup → Linearization → Y-val</p>
4	<p>To enter another point in the table, select the "Next point" option via the "Edit table" parameter. Enter the next point as explained in Step 3. Menu path: Setup → Extended setup → Linearization → Edit table</p>
5	<p>Once all the points have been entered in the table, select the "Activate table" option via the "Lin. mode" parameter. Menu path: Setup → Extended setup → Linearization → Lin. mode</p>
6	<p>Result: Result: The measured value after linearization is displayed.</p>



h Height
i Current value
v Volume

A0017670

-  Error message F510 "Linearization" and alarm current as long as the table is being entered and until the table is activated.
-  Error message F511/F512 "Linearization" and alarm current as long as the linearization table consists of fewer than 2 points.
-  The lower-range value (= 4mA) is defined by the smallest point in the table. The upper-range value (= 20mA) is defined by the largest point in the table.
-  Using the parameters "Set LRV" and "Set URV", you can change the allocation of the volume/mass values to the current values.

9.13 Manual entry of a linearization table via operating tool

The following options are available to you with an operating tool that is based on FDT technology (e.g. FieldCare), you can enter linearization using a module specially designed for this purpose. This provides you with an overview of the selected linearization, even during entry. In addition, it is possible to configure different tank shapes in FieldCare ("Device operation" → "Device functions" → "Additional functions" → "Linearization table" menu).

-  The linearization table may also be entered manually point by point in the operating tool menu (see section).



9.14 Backing up or duplicating the device data

The following options are available to you with an operating tool that is based on FDT technology (e.g. FieldCare):

- Storage/recovery of configuration data.
- Duplication of device parameters.
- Transfer of all relevant parameters when replacing electronic inserts.

Use the following parameter for this:

Download select. (visible only in FieldCare)

Navigation	  Expert → System → Management → Download select.
Write permission	Operators/Service engineers/Expert
Description	Selection of data packages for up/download function in Fieldcare and PDM.
Prerequisite	DIP switch set to "SW" and "Damping" set to "on". If you download using the factory setting "Configuration copy", all parameters required for a measurement will be downloaded. The functionality of the "Electronics replace" setting is reserved for Endress+Hauser Service and can be accessed only if the correct device access code is entered.
Options	<ul style="list-style-type: none"> ■ Configuration copy: This option overwrites general configuration parameters with the exception of the serial number, order number, calibration, pos. zero adjust, application and day information. ■ Device replacement: This option overwrites general configuration parameters with the exception of the serial number, order number, calibration and position adjustment. ■ Electronics replace: This option overwrites general configuration parameters.
Factory setting	Configuration copy

10 Diagnostics and troubleshooting

10.1 Troubleshooting

General errors

Error	Possible cause	Solution
Device is not responding.	Supply voltage does not match the specification on the nameplate.	Apply correct voltage.
	Supply voltage has incorrect polarity.	Reverse polarity of supply voltage.
	Connecting cables are not in contact with the terminals.	Check the connection of the cables and correct if necessary.
Output current < 3.6 mA	Signal line is not wired correctly. Electronics unit is defective.	Check wiring.
Device measures incorrectly.	Configuration error	Check and correct parameter configuration (see below).
HART communication is not working.	Communication resistor missing or incorrectly installed.	Install the communication resistor (250 Ω) correctly.
	Commubox is not properly connected.	Connect Commubox correctly .
	Commubox is not set to "HART".	Set Commubox selector switch to "HART".

10.2 Diagnostic events

10.2.1 Diagnostic message

Faults detected by the self-monitoring system of the measuring device are displayed as a diagnostic message in alternation with the measured value display.

Status signals

The table →  65 lists the messages that may occur. The ALARM STATUS parameter shows the message with the highest priority. The device has four different status information codes according to NE107:

F A0013956	"Failure" A device error has occurred. The measured value is no longer valid.
M A0013957	"Maintenance required" Maintenance is required. The measured value remains valid.
C A0013959	"Function check" The device is in service mode (e.g. during a simulation).
S A0013958	"Out of specification" The device is being operated: <ul style="list-style-type: none"> ▪ Outside its technical specifications (e.g. during warm-up or cleaning). ▪ Outside the parameter configuration undertaken by the user (e.g. level outside of configured span)

Diagnostic event and event text

The fault can be identified by means of the diagnostic event.

The event text helps you by providing information on the fault.

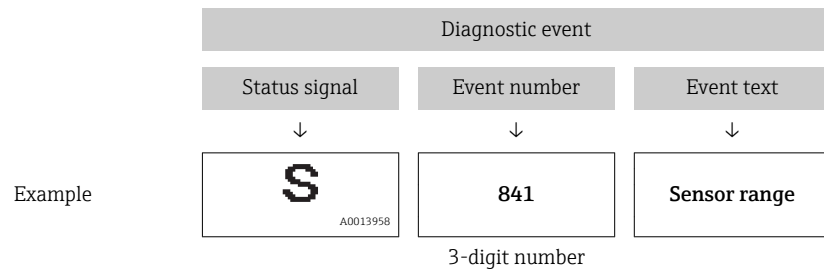

If two or more diagnostic events are pending simultaneously, only the diagnostic message with the highest priority is shown.

Other diagnostic messages that are pending can be viewed in the **Diagnostic list** submenu .

 Past diagnostic messages that are no longer pending are shown in the **Event logbook** submenu .

10.2.2 List of diagnostic events

General messages

Diagnostic event		Reason	Corrective measure
Code	Description		
0	No error	-	-

"F" messages

Diagnostic event		Reason	Corrective measure
Code	Description		
F002	Sensor unknown	Sensor does not suit the device (electronic sensor nameplate).	Contact Endress+Hauser Service
F062	Sensor conn.	<ul style="list-style-type: none"> ▪ Faulty sensor. ▪ Electromagnetic effects are greater than specifications in the technical data. This message appears for a short time only. 	<ul style="list-style-type: none"> ▪ Check the sensor module cable ▪ Contact Endress+Hauser Service
F081	Initialization	<ul style="list-style-type: none"> ▪ Faulty sensor. ▪ Electromagnetic effects are greater than specifications in the technical data. This message appears for a short time only. 	<ul style="list-style-type: none"> ▪ Check sensor cable ▪ Contact Endress+Hauser Service
F083	Memory content	<ul style="list-style-type: none"> ▪ Faulty sensor. ▪ Electromagnetic effects outside the permitted range. This message appears for a short time only. 	<ul style="list-style-type: none"> ▪ Restart the device ▪ Contact Endress+Hauser Service
F140	Working range P	<ul style="list-style-type: none"> ▪ Overpressure and low pressure present. ▪ Electromagnetic effects outside the permitted range. ▪ Faulty sensor. 	<ul style="list-style-type: none"> ▪ Check the process pressure ▪ Check sensor range
F261	Electronic module	<ul style="list-style-type: none"> ▪ Main electronics defective. ▪ Fault in the main electronics. 	Restart the device
F282	Memory	<ul style="list-style-type: none"> ▪ Fault in the main electronics. ▪ Main electronics defective. 	Restart the device

Diagnostic event		Reason	Corrective measure
Code	Description		
F283	Memory content	<ul style="list-style-type: none"> ▪ Main electronics defective. ▪ Electromagnetic effects are greater than specifications in the technical data. ▪ The supply voltage is disconnected when writing. ▪ An error occurred when writing. 	Perform a reset
F411	Up-/download	<ul style="list-style-type: none"> ▪ File is defective. ▪ During the download, the data are not correctly transmitted to the processor, e.g. because of open cable connections, spikes (ripple) on the supply voltage or electromagnetic effects. 	<ul style="list-style-type: none"> ▪ Repeat download ▪ Use other file ▪ Perform a reset
F510	Linearization	The linearization table is being edited.	<ul style="list-style-type: none"> ▪ Conclude entries ▪ Select "linear"
F511	Linearization	The linearization table consists of less than 2 points.	<ul style="list-style-type: none"> ▪ Table too small ▪ Correct table ▪ Activate table
F512	Linearization	The linearization table is not monotonic increasing or decreasing.	<ul style="list-style-type: none"> ▪ Table not monotonic ▪ Correct table ▪ Activate table
F841	Sensor range	<ul style="list-style-type: none"> ▪ Overpressure or low pressure present. ▪ Faulty sensor. 	<ul style="list-style-type: none"> ▪ Check the pressure value ▪ Contact Endress+Hauser Service
F882	Input signal	External measured value is not received or displays a failure status.	<ul style="list-style-type: none"> ▪ Check the bus ▪ Check source device ▪ Check the setting

"M" messages

Diagnostic event		Reason	Corrective measure
Code	Description		
M002	Sens. unknown	Sensor does not suit the device (electronic sensor nameplate). Device continues measuring.	Contact Endress+Hauser Service
M283	Memory content	<ul style="list-style-type: none"> ▪ Cause as indicated for F283. ▪ Correct measurement can continue as long as you do not need the peakhold indicator function. 	Perform a reset
M431	Adjustment	The calibration carried out would result in values that exceed or fall below the nominal range of the sensor.	<ul style="list-style-type: none"> ▪ Check the measuring range ▪ Check position adjustment ▪ Check the setting
M434	Scaling	<ul style="list-style-type: none"> ▪ Values for calibration (e.g. lower-range value and upper-range value) are too close together. ▪ Lower-range value and/or upper-range value exceed or fall below the range limits of the sensor. ▪ The sensor was replaced and the customer-specific configuration does not suit the sensor module. ▪ Unsuitable download carried out. 	<ul style="list-style-type: none"> ▪ Check the measuring range ▪ Check the setting ▪ Contact Endress+Hauser Service
M438	Data set	<ul style="list-style-type: none"> ▪ The supply voltage is disconnected when writing. ▪ An error occurred when writing. 	<ul style="list-style-type: none"> ▪ Check the setting ▪ Restart the device
M882	Input signal	External measured value displays a warning status.	<ul style="list-style-type: none"> ▪ Check the bus ▪ Check the source device ▪ Check the setting

"C" messages

Diagnostic event		Reason	Corrective measure
Code	Description		
C412	Backup in prog.	Downloading.	Wait for download to complete.
C482	Simul. output	Simulation of the current output is switched on, i.e. the device is not measuring at present.	End the simulation
C484	Error simul.	Simulation of an error status is switched on, i.e. the device is not measuring at present.	End the simulation
C485	Measure simul.	Simulation is switched on, i.e. the device is not measuring at present.	End the simulation
C824	Process pressure	<ul style="list-style-type: none"> ▪ Overpressure or low pressure present. ▪ Electromagnetic effects outside the permitted range. This message appears for a short time only. 	<ul style="list-style-type: none"> ▪ Check the pressure value ▪ Restart the device ▪ Perform a reset

"S" messages

Diagnostic event		Reason	Corrective measure
Code	Description		
S110	Operational range T	<ul style="list-style-type: none"> ▪ High temperature or low temperature present. ▪ Electromagnetic effects outside the permitted range. ▪ Faulty sensor. 	<ul style="list-style-type: none"> ▪ Check process temperature ▪ Check the temperature range
S140	Working range P LP/HP	<ul style="list-style-type: none"> ▪ Overpressure or low pressure present. ▪ Electromagnetic effects outside the permitted range. ▪ Faulty sensor. 	<ul style="list-style-type: none"> ▪ Check the process pressure ▪ Check sensor range
S822	Process temp. LP/HP	<ul style="list-style-type: none"> ▪ The temperature measured in the sensor is higher than the upper nominal temperature of the sensor. ▪ The temperature measured in the sensor is lower than the lower nominal temperature of the sensor. 	<ul style="list-style-type: none"> ▪ Check temperature ▪ Check the setting
S841	Sensor range	<ul style="list-style-type: none"> ▪ Overpressure or low pressure present. ▪ Faulty sensor. 	<ul style="list-style-type: none"> ▪ Check the pressure value ▪ Contact Endress+Hauser Service
S971	Adjustment	<ul style="list-style-type: none"> ▪ The current is outside the permitted range from 3.8 to 20.5 mA. ▪ The present pressure value is outside the configured measuring range (but within the sensor module range, if applicable). ▪ The calibration carried out would result in values that exceed or fall below the nominal range of the sensor. 	<ul style="list-style-type: none"> ▪ Check the pressure value ▪ Check the measuring range ▪ Check the setting

10.3 Troubleshooting specific to Waterpilot FMX21 with optional Pt100

Error description	Reason	Corrective action
No measuring signal	4 to 20 mA cable not connected correctly	Connect device as per.
	No power supplied via the 4 to 20 mA cable	Check current loop.
	Supply voltage too low (at least 10.5 V DC)	<ul style="list-style-type: none"> ▪ Check supply voltage. ▪ Overall resistance greater than max. load resistance

Error description	Reason	Corrective action
	Waterpilot defective	Replace the Waterpilot.
Temperature measured value is inaccurate/incorrect (only for Waterpilot FMX21 with Pt100)	Pt100 connected in 2-wire circuit, cable resistance was not compensated for	<ul style="list-style-type: none"> ■ Compensate the cable resistance. ■ Connect Pt100 as 3-wire or 4-wire circuit.

10.4 Troubleshooting specific to TMT182 temperature head transmitter

Error description	Reason	Corrective action
No measuring signal	4 to 20 mA cable not connected correctly	Connect device as per.
	No power supplied via the 4 to 20 mA cable	Check current loop.
	Supply voltage too low (at least 10.5 V DC)	<ul style="list-style-type: none"> ■ Check supply voltage. ■ Overall resistance greater than max. load resistance
Error current ≤ 3.6 mA or ≥ 21 mA	Pt100 not connected correctly	Connect device as per.
	4 to 20 mA cable not connected correctly	Connect device as per.
	Pt100 resistance thermometer defective	Replace the Waterpilot.
	Temperature head transmitter defective	Replace the temperature head transmitter.
Measured value is inaccurate/incorrect	Pt100 connected in 2-wire circuit, cable resistance was not compensated for	<ul style="list-style-type: none"> ■ Compensate the cable resistance. ■ Connect Pt100 as 3-wire or 4-wire circuit.

10.5 Response of output to errors

The behavior of the current output in case of fault is defined by the following parameters:

- "Alarm behav. P (050)"
- "Output fail mode (190)"
- "High alarm curr. (052)"

10.6 Firmware history

Date	Firmware version	Modifications	Documentation
05.2009	01.00.zz	Original firmware. Compatible with: <ul style="list-style-type: none">▪ FieldCare from version 2.02.00▪ Field Communicator DXR375 with Device Rev.: 1, DD Rev.: 1	BA00380P/00/EN/08.09

11 Maintenance

No special maintenance work is required.

Terminal box: Keep the pressure compensation tube and GORE-TEX® filter free from contamination.

11.1 Exterior cleaning

Please note the following points when cleaning the device:

- The cleaning agents used should not corrode the surface and the seals.
- Mechanical damage to the process isolating diaphragm, e.g. due to sharp objects, must be avoided.
- Only clean the terminal box with water or with a cloth dampened with very diluted ethanol.

12 Repairs

12.1 General notes

12.1.1 Repair concept

Repairs are not possible.

12.1.2 Replacing a device

Once a complete device has been replaced, the parameters can be transferred back into the device using FieldCare:

Prerequisite: The configuration of the old device was saved previously to the computer using FieldCare.

You can continue to measure without performing a new calibration.

12.2 Spare parts

- Some replaceable measuring device components are identified by means of a spare part nameplate. This contains information about the spare part.
- All the spare parts for the measuring device along with the order code are listed in the *W@M Device Viewer* (www.endress.com/deviceviewer) and can be ordered. If available, users can also download the associated Installation Instructions.



Measuring device serial number:

- Located on the device and spare part nameplate.
- Can be read out via the "Serial number" parameter in the "Instrument info" submenu.

12.3 Return

The measuring device must be returned in the event of a factory calibration, or if the wrong device has been ordered or delivered.

As an ISO-certified company and due to legal requirements,

Endress+Hauser is required to follow certain procedures when handling returned products that have been in contact with a medium. To ensure swift, safe and professional device returns, please read the return procedures and conditions on the Endress+Hauser website at www.services.endress.com/return-material

► Select country.

↳ The web site of the responsible sales office opens with all of the relevant information relating to returns.

1. If the desired country is not listed:

Click on the "Choose your location" link.

↳ An overview of Endress+Hauser sales offices and representatives opens.

2. Contact your Endress+Hauser sales office or representative.

12.4 Disposal

When disposing, separate and recycle the device components based on the materials.

13 Overview of the operating menu





i Depending on the parameter configuration, not all submenus and parameters are available. Information on this can be found in the parameter description under "Prerequisite".









Setup	Description
Mode	→ 83
Press. eng. unit	→ 85
Corrected press.	→ 87
Pos. zero adjust (relative pressure sensor)	→ 84
Calib. offset (absolute pressure sensor)	→ 84
Empty calib. ("Level" measuring mode and "Calibration mode" = wet)	→ 89
Full calib. ("Level" measuring mode and "Calibration mode" = wet)	→ 90
Set LRV ("Pressure" measuring mode)	→ 86
Set URV ("Pressure" measuring mode)	→ 86
Damping	→ 84
Level before Lin ("Level" measuring mode)	→ 92
Press after damping	→ 87





Setup →	Extended setup	Description
	Code definition	→ 80
	Device tag	→ 81
	Operator code	→ 80











Setup →	Extended setup →	Level ("Level" measuring mode)	Description
		Level selection	→ 88
		Output unit	→ 88
		Height unit	→ 88
		Calibration mode	→ 89
		Empty calib.	→ 89
		Empty pressure	→ 89
		Empty height	→ 90
		Full calib.	→ 90
		Full pressure	→ 90
		Full height	→ 91
		Adjust density	→ 91
		Process density	→ 92
		Level before lin	→ 92







Setup →	Extended setup →	Linearization	Description
		Lin. mode	→ 93
		Unit after lin.	→ 93
		Line-numb:	→ 93

Setup →	Extended setup →	Linearization	Description
		X-val	→  94
		Y-val	→  94
		Edit table	→  94
		Tank description	→  95
		Tank content	→  95

Setup →	Extended setup →	Current output	Description
		Alarm behav. P	→  98
		Output fail mode	→  98
		Max. alarm curr.	→  98
		Set min. current	→  99
		Output current	→  98
		Get LRV (only "Pressure")	→  99
		Set LRV	→  99
		Get URV (only "Pressure")	→  99
		Set URV	→  100

Diagnosis	Description
Diagnostic code	→  112
Last diag. code	→  112
Min. meas. press.	→  112
Max. meas. press.	→  112

Diagnosis →	Diagnostics List	Description
	Diagnostic 1	→  114
	Diagnostic 2	→  114
	Diagnostic 3	→  114
	Diagnostics 4	→  114
	Diagnostics 5	→  114
	Diagnostics 6	→  114
	Diagnostics 7	→  114
	Diagnostics 8	→  114
	Diagnostics 9	→  114
	Diagnostics 10	→  114

Diagnosis →	Event logbook	Description
	Last diag. 1	→  115
	Last diag. 2	→  115
	Last diag. 3	→  115
	Last diag. 4	→  115
	Last diag. 5	→  115
	Last diag. 6	→  115

Diagnosis →	Event logbook	Description
	Last diag. 7	→ ⓘ 115
	Last diag. 8	→ ⓘ 115
	Last diag. 9	→ ⓘ 115
	Last diag. 10	→ ⓘ 115

Diagnosis →	Instrument Info	Description
	Firmware Version	→ ⓘ 81
	Serial number	→ ⓘ 81
	Ext. order code	→ ⓘ 81
	Order Identifier	→ ⓘ 82
	Cust. tag number	→ ⓘ 81
	Device tag	→ ⓘ 81
	ENP version	→ ⓘ 82
	Config. counter	→ ⓘ 113
	LRL sensor	→ ⓘ 96
	URL sensor	→ ⓘ 96
	Manufacturer ID	→ ⓘ 104
	Device type	→ ⓘ 104
	Device revision	→ ⓘ 104

Diagnosis →	Measured values	Description
	Level before lin	→ ⓘ 92
	Tank content	→ ⓘ 95
	Pressure measured	→ ⓘ 86
	Sensor pressure	→ ⓘ 86
	Corrected press.	→ ⓘ 87
	Press after damping	→ ⓘ 87
	Sensor temp.	→ ⓘ 85



Diagnosis →	Simulation	Description
	Simulation mode	→ ⓘ 116
	Sim. pressure	→ ⓘ 116
	Sim. level	→ ⓘ 116
	Sim. tank cont.	→ ⓘ 117
	Sim. current	→ ⓘ 117
	Sim. alarm/warning	→ ⓘ 117









Diagnosis →	Enter reset code	Description
	Enter reset code	→ ⓘ 83

13.1 Overview of parameters in the "Expert" menu

 The following table lists all of the parameters that can be included in the "Expert" menu. The page reference indicates where a description of the parameter can be found in the manual.







Depending on the device version and the parameter configuration, not all submenus and parameters are available in every device. Information on this can be found in the parameter description under "Prerequisite".







Expert →	System	Description
	Code definition	→  80
	Operator code	→  80

Expert →	System →	Instrument Info	Description
		Cust. tag number	→  81
		Device tag	→  81
		Serial number	→  81
		Firmware Version	→  81
		Ext. order code	→  81
		Order Identifier	→  82
		ENP version	→  82
		Electr.Serial No	→  82
		Sensor serial no.	→  82

Expert →	System →	Administration	Description
		Enter reset code	→  83

Expert →	Measurement	Description
	Mode	→  83

Expert →	Measurement →	Basic Setup	Description
		Pos. zero adjust	→  84
		Calib. Offset	→  84
		Damping	→  84
		Press. eng. unit	→  85
		Temp. Eng. Unit	→  85
		Sensor temp.	→  85

Expert →	Measurement →	Meas.	Description
		Set LRV	→  86
		Set URV	→  86
		Pressure measured	→  86
		Sensor pressure	→  86
		Corrected press.	→  87
		Press after damping	→  87

Expert →	Measurement→	Level	Description
		Level selection	→ 88
		Output unit	→ 88
		Height unit	→ 88
		Calibration mode	→ 89 → 89
		Empty calib.	
		Empty pressure	→ 89
		Empty height	→ 90
		Full calib.	→ 90
		Full pressure	→ 90
		Full height	→ 91
		Density unit	→ 91
		Adjust density	→ 91
		Process density	→ 92
		Level before lin.	→ 92

Expert →	Measurement→	Linearization	Description
		Lin. mode	→ 93
		Unit after lin.	→ 93
		Line-numb:	→ 93
		X-val	→ 94
		Y-val	→ 94
		Edit table	→ 94
		Tank description	→ 95
		Tank content	→ 95

Expert →	Measurement→	Sensor limits	Description
		Lower range limit	→ 96
		URL sensor	→ 96

Expert →	Measurement→	Sensor trim	Description
		Lo trim measured	→ 97
		Hi trim measured	→ 97
		Lo Trim Sensor	→ 97
		Hi Trim Sensor	→ 97

Expert →	Output→	Current output	Description
		Output current	→ 98
		Alarm behav. P	→ 98
		Output fail mode	→ 98
		Max. alarm curr.	→ 98
		Set min. current	→ 99



Expert →	Output→	Current output	Description
		Get LRV ("Pressure" only)	→ 100 99
		Set LRV	→ 100 99
		Get URV ("Pressure" only)	→ 100 99
		Set URV	→ 100 100
		Start-up current	→ 100 100
		Curr. Trim 4 mA	→ 100 100
		Curr. Trim 20 mA	→ 100 101
		Offset Trim 4 mA	→ 100 101
		Offset Trim 20 mA	→ 100 101



Expert →	Communication→	HART Config	Description
		Burst Mode	→ 100 102
		Burst Option	→ 100 102
		Current Mode	→ 100 102
		Bus Address	→ 100 102
		Preamble Number	→ 100 103









Expert →	Communication→	HART Info	Description
		Device type	→ 100 104
		Device revision	→ 100 104
		Manufacturer ID	→ 100 104
		HART version	→ 100 104
		Description	→ 100 104
		HART Message	→ 100 104
		HART Date	→ 100 105











Expert →	Communication→	HART Output	Description
		Primary value is	→ 100 106
		Primary value	→ 100 106
		Secondary val. is	→ 100 106
		Secondary value	→ 100 106
		Third value is	→ 100 107
		Third value	→ 100 107
		4th value is	→ 100 107
		4th value	→ 100 108











Expert →	Communication→	HART Input	Description
		HART input val.	→ 100 109
		HART input stat.	→ 100 109







Expert →	Communication→	HART Input	Description
		HART input unit	→  109
		HART input form.	→  109

Expert →	Application	Description
	Electr. Delta P	→  111
	Fixed ext. value	→  111
	Auto dens. corr.	→  111

Expert →	Diagnosis	Description
	Diagnostic code	→  112
	Last diag. code	→  112
	Reset Logbook	→  112
	Min. meas. press.	→  112
	Max. meas. press.	→  112
	Reset Peakhold	→  113
	Operating hours	→  113
	Config. counter	→  113

Expert →	Diagnosis→	Diagnostics List	Description
		Diagnostic 1	→  114
		Diagnostic 2	→  114
		Diagnostic 3	→  114
		Diagnostics 4	→  114
		Diagnostics 5	→  114
		Diagnostics 6	→  114
		Diagnostics 7	→  114
		Diagnostics 8	→  114
		Diagnostics 9	→  114
		Diagnostics 10	→  114

Expert →	Diagnosis→	Event logbook	Description
		Last diag. 1	→  115
		Last diag. 2	→  115
		Last diag. 3	→  115
		Last diag. 4	→  115
		Last diag. 5	→  115
		Last diag. 6	→  115
		Last diag. 7	→  115
		Last diag. 8	→  115
		Last diag. 9	→  115
		Last diag. 10	→  115

Expert →	Diagnosis→	Simulation	Description
		Simulation mode	→  116
		Sim. pressure	→  116
		Sim. level	→  116
		Sim. tank cont.	→  117
		Sim. current	→  117
		Sim. alarm/warning	→  117

14 Description of device parameters

14.1 Expert → System

Operator code	
<hr/>	
Write permission	Operators/Service engineers/Expert
Description	Use this function to enter a code to lock or unlock operation.
User entry	<ul style="list-style-type: none"> ▪ To lock: Enter a number ≠ the release code (value range: 1 to 9999). ▪ To unlock: Enter the release code.
Note	The release code is "0" in the order configuration. Another release code can be defined in the "Code definition" parameter. If the user has forgotten the release code, the release code can be visible by entering the number "5864".
Factory setting	0



Code definition	
<hr/>	
Write permission	Operators/Service engineers/Expert
Description	Use this function to enter a release code with which the device can be unlocked.
Options	A number from 0 to 9999
Factory setting	0

14.2 Expert → System → Instrument info

Cust. tag number

Write permission	Operators/Service engineers/Expert
Description	Enter the device tag e.g. TAG number (max. 8 alphanumeric characters).
Factory setting	No entry or according to order specifications

Device tag

Navigation	  Setup → Extended setup → Device tag
Write permission	Operators/Service engineers/Expert
Description	Enter the device tag e.g. TAG number (max. 32 alphanumeric characters).
Factory setting	No entry or according to order specifications

Serial number

Write permission	Parameter is read only. Only Endress+Hauser Service has write permission.
Description	Displays the serial number of the device (11 alphanumeric characters).

Firmware Version

Write permission	No write permissions. Parameter is read only.
Description	Displays the firmware version.

Ext. order code

Write permission	Parameter is read only. Only Endress+Hauser Service has write permission.
Description	Displays extended order number.
Factory setting	According to order specifications

Order identifier

Navigation	 Diagnosis → Instrument info → Order identifier
Write permission	Parameter is read only. Only Endress+Hauser Service has write permission.
Description	Displays the order identifier.
Factory setting	According to order specifications

ENP version

Write permission	Operators/Service engineers/Expert
Description	Displays the ENP version (ENP = electronic nameplate)

Electr.serial no

Write permission	No write permissions. Parameter is read only.
Description	Displays the serial number of the main electronics (11 alphanumeric characters).

Sensor serial no.

Write permission	No write permissions. Parameter is read only.
Description	Displays the serial number of the main electronics (11 alphanumeric characters).

14.3 Expert → System → Management

Enter reset code

Write permission	Operators/Service engineers/Expert
Description	Reset parameters completely or partially to the factory values or order configuration by entering a reset code, see "Resetting to factory settings (reset)" section.
Factory setting	0

14.4 Expert → Measurement → Measuring mode

Measuring mode

⚠ WARNING

Changing the measuring mode affects the span (URV)

This situation can result in product overflow.

- ▶ If the measuring mode is changed, the setting for the span (URV) must be checked in the "Setup" operating menu and readjusted if necessary.

Write permission	Operators/Service engineers/Expert
Description	Select the measuring mode. The operating menu is structured differently depending on the measuring mode selected.
Options	<ul style="list-style-type: none"> ▪ Meas. ▪ Level
Factory setting	Pressure or according to order specifications

14.5 Expert → Measurement → Basic setup

Pos. zero adjust	
-------------------------	--

Write permission	Operators/Service engineers/Expert
Description	Position adjustment – the pressure difference between zero (set point) and the measured pressure need not be known.
Example	<ul style="list-style-type: none"> ▪ Measured value = 2.2 mbar (0.033 psi) ▪ You correct the measured value via the "Pos. zero adjust" parameter with the "Confirm" option. i.e. This means that you are assigning the value 0.0 to the pressure present. ▪ Measured value (after position adjustment) = 0.0 mbar ▪ The current value is also corrected.
Options	<ul style="list-style-type: none"> ▪ Confirm ▪ Cancel
Factory setting	Cancel

Calib. offset	
----------------------	--

Write permission	Service engineers/Expert
Description	Position adjustment – the pressure difference between the set point and the measured pressure must be known.
Example	<ul style="list-style-type: none"> ▪ Measured value = 982.2 mbar (14.73 psi) ▪ You use the "Calib. offset" parameter to correct the measured value with the value entered, e.g. 2.2 mbar (0.033 psi). i.e. This means that you are assigning the value 980.0 (14.7 psi) to the pressure present. ▪ Measured value (after pos. zero adjust) = 980.0 mbar (14.7 psi) ▪ The current value is also corrected.
Factory setting	0.0

Damping	
----------------	--

Write permission	Operators/Service engineers/Expert (if the "Damping" DIP switch is set to "on")
Description	Enter damping time (time constant τ). The damping affects the speed at which the measured value reacts to changes in pressure.
Input range	0.0 to 999.0 s
Factory setting	2.0 sec. or according to order specifications

Press. eng. unit

Write permission	Operators/Service engineers/Expert
Description	Select the pressure engineering unit. If a new pressure engineering unit is selected, all pressure-specific parameters are converted and displayed with the new unit.
Options	<ul style="list-style-type: none"> ■ mbar, bar ■ mmH2O, mH2O, inH2O ■ ftH2O ■ Pa, kPa, MPa ■ psi ■ mmHg, inHg ■ kgf/cm²
Factory setting	mbar or bar depending on the nominal measuring range of the sensor module, or as per order specifications

Temp. eng. unit

Write permission	Service engineers/Expert
Description	Select the unit for the temperature measured values.
Options	<ul style="list-style-type: none"> ■ °C ■ °F ■ K
Note	The setting affects the unit for the "Sensor temp." parameter.
Factory setting	°C

Sensor temp.

Write permission	No write permissions. Parameter is read only.
Description	Displays the temperature currently measured in the sensor module. This can deviate from the process temperature.

14.6 Expert → Measurement → Pressure

Set LRV

Write permission	Operators/Service engineers/Expert
Description	Set the pressure value, level or content for the lower current value (4 mA).
Factory setting	<ul style="list-style-type: none"> ■ 0.0 % in Level measuring mode ■ 0.0 mbar/bar or in accordance with ordering information in Pressure measuring mode

Set URV

Write permission	Operators/Service engineers/Expert
Description	Set the pressure value, level or content for the upper current value (20 mA).
Factory setting	<ul style="list-style-type: none"> ■ 100.0 % in Level measuring mode ■ URL Sensor or according to ordering information in Pressure measuring mode

Meas. pressure

Write permission	No write permissions. Parameter is read only.
Description	Displays the measured pressure after sensor trim, position adjustment and damping.

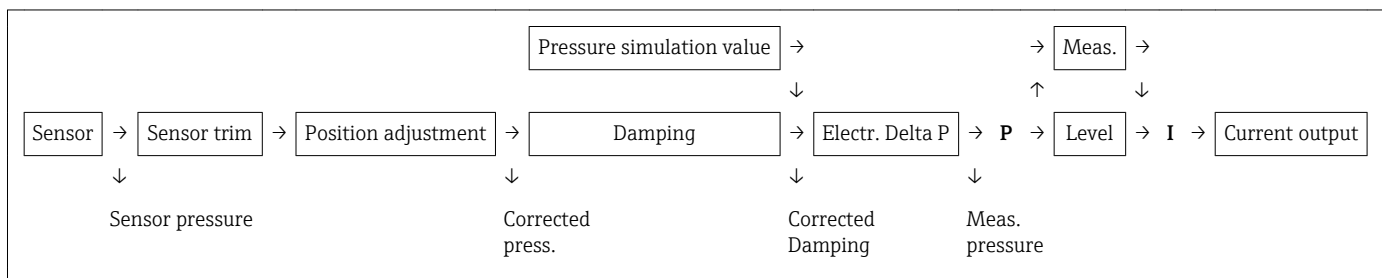

Sensor pressure

Write permission	No write permissions. Parameter is read only.
Description	Displays the measured pressure before the sensor trim.

Corrected press.

Write permission No write permissions. Parameter is read only.

Description Displays the measured pressure after sensor trim and position adjustment.

Pressure after damping

Write permission No write permissions. Parameter is read only.

Description Displays the measured pressure after sensor trim, position adjustment and damping.

14.7 Expert → Measurement → Level

Level selection

Write permission Operators/Service engineers/Expert

Description Select the method for calculating the level

Options

- In pressure
If this option is selected, specify two pressure/level value pairs. The level value is displayed directly in the unit that you select via the "Output unit" parameter.
- In height
If this option is selected, specify two height/level value pairs. From the measured pressure, the device first calculates the height using the density. Along with the two value pairs specified, this information is then used to calculate the level in the "Output unit" selected.

Factory setting In pressure

Output unit

Description Select the unit for the measured value display for the level before linearization.

Note The selected unit is used only to describe the measured value i.e. when a new output unit is selected, the measured value is not converted.

Example

- Current measured value: 0.3 ft
- New output unit: m
- New measured value: 0.3 m

Options

- %
- mm, cm, dm, m
- ft, inch
- m³, in³
- l, hl
- ft³
- gal, lgal
- kg, t
- lb

Factory setting %

Height unit

Write permission Operators/Service engineers/Expert

Description	Select the height unit. The measured pressure is converted to the selected height unit using the "Adjust Density" parameter.
Prerequisite	"Level selection" = "In height"
Options	<ul style="list-style-type: none"> ■ mm ■ m ■ in ■ ft
Factory setting	m

Calibration mode

Write permission	Operators/Service engineers/Expert
Description	Select the calibration mode.
Options	<ul style="list-style-type: none"> ■ Wet Wet calibration takes place by filling and emptying the vessel. In the case of two different levels, the level, volume, mass or percentage value entered is assigned to the pressure measured at this point in time ("Empty calib." and "Full calib." parameters). ■ Dry Dry calibration is a theoretical calibration. For this calibration, you specify two pressure-level value pairs or height-level value pairs via the following parameters: "Empty calib.", "Empty pressure", "Empty height", "Full calib.", "Full pressure", "Full height".
Factory setting	Wet

Empty calib.

Write permission	Operators/Service engineers/Expert
Description	Enter the output value for the lower calibration point (vessel is empty). The unit defined in "Output unit" must be used here.
Note	<ul style="list-style-type: none"> ■ For wet calibration, the level (e.g. empty or partially filled vessel) must actually be present. The associated pressure is then automatically recorded by the device. ■ In the case of dry calibration, the level (vessel empty) does not have to be available. For the "In pressure" level selection, the associated pressure must be entered in the "Empty pressure" parameter. The associated height must be entered in the "Empty height" parameter for the "In height" level selection.
Factory setting	0.0

Empty pressure

Write permission	Operators/Service engineers/Expert
Description	Enter the pressure value for the lower calibration point (vessel empty). See also "Empty calib.".
Prerequisite	<ul style="list-style-type: none"> ■ "Level selection" = In pressure ■ "Calibration mode" = Dry -> entry ■ "Calibration mode" = Wet -> display
Factory setting	0.0

Empty height

Write permission	Operators/Service engineers/Expert
Description	Enter the height value for the lower calibration point (vessel empty). The unit is selected via the "Height unit" parameter.
Prerequisite	<ul style="list-style-type: none"> ■ "Level selection" = "In height" ■ "Calibration mode" = Dry -> entry ■ "Calibration mode" = Wet -> display
Factory setting	0.0

Full calib.

Write permission	Operators/Service engineers/Expert
Description	Enter the output value for the upper calibration point (vessel full). The unit defined in "Output unit" must be used here.
Note	<ul style="list-style-type: none"> ■ For wet calibration, the level (e.g. empty or partially filled vessel) must actually be present. The associated pressure is then automatically recorded by the device. ■ In the case of dry calibration, the level (vessel full) does not have to be available. For the "In pressure" level selection, the associated pressure must be entered in the "Full pressure" parameter. The associated height has to be entered in the "Full height" parameter for the "In height" level selection.
Factory setting	100.0

Full pressure

Write permission	Operators/Service engineers/Expert
Description	Enter the pressure value for the upper calibration point (vessel full). See also "Full calib.".

Prerequisite	<ul style="list-style-type: none"> ■ "Level selection" = In pressure ■ "Calibration mode" = Dry -> entry ■ "Calibration mode" = Wet -> display
---------------------	---

Factory setting	URL of the sensor module
------------------------	--------------------------

Full height

Write permission	Operators/Service engineers/Expert
-------------------------	------------------------------------

Description	Enter the height value for the upper calibration point (vessel full). The unit is selected via the "Height unit" parameter.
--------------------	---

Prerequisite	<ul style="list-style-type: none"> ■ "Level selection" = "In height" ■ "Calibration mode" = Dry -> entry ■ "Calibration mode" = Wet -> display
---------------------	---

Factory setting	URL is converted to a level unit
------------------------	----------------------------------

Density unit

Write permission	Service engineers/Expert
-------------------------	--------------------------

Description	Displays the density unit. The measured pressure is converted to a height using the "Height unit", "Adjust density" and "Process density" parameters.
--------------------	---

Options	<ul style="list-style-type: none"> ■ g/cm³ ■ kg/m³ ■ kg/dm³ ■ lb/in³ ■ lb/ft³
----------------	---

Factory setting	g/cm ³
------------------------	-------------------

Adjust density

Write permission	Operators/Service engineers/Expert
-------------------------	------------------------------------

Description	<p>Enter the density of the medium used to perform the calibration. The measured pressure is converted to a height using the "Height unit" and "Adjust density" parameters.</p> <p>Input: Auto dens. corr. = Off Display: Auto dens. corr. ≠ Off</p>
--------------------	---

Factory setting	1.0
------------------------	-----

Process density

Write permission Operators/Service engineers/Expert

Description Enter a new density value for density correction. The calibration was carried out with the medium water, for example. Now the vessel is to be used for another medium with another density. The calibration is corrected appropriately by entering the new density value in the "Process Density" parameter.
Input: Auto dens. corr. = Off
Display: Auto dens. corr. ≠ Off

Note If, after completing a wet calibration, you change to dry calibration using the "Calibration mode" parameter, the density for the "Adjust density" and "Process density" parameters must be entered correctly before changing the calibration mode.

Factory setting 1.0

Level before lin.

Write permission No write permissions. Parameter is read only.

Description Displays the level value prior to linearization.

14.8 Expert → Measurement → Linearization

Lin. mode

Write permission	Operators/Service engineers/Expert
Description	Select the linearization mode.
Options	<ul style="list-style-type: none"> ▪ Linear The level is output without being converted beforehand. "Level before lin" is output. ▪ Erase table The existing linearization table is deleted. ▪ Manual entry (sets the table to edit mode, an alarm is output): The value pairs of the table (X-value and Y-value) are entered manually. ▪ Semi-automatic entry (sets the table to edit mode, an alarm is output): The vessel is emptied or filled in stages in this entry mode. The device automatically records the level value (X-value). The associated volume, mass or % value is entered manually (Y-value). ▪ Activate table The table entered is activated and checked with this option. The device shows the level after linearization.
Factory setting	Linear

Unit after lin.

Write permission	Operators/Service engineers/Expert
Description	Select volume unit, mass, height or % (unit of the Y-value).
Options	<ul style="list-style-type: none"> ▪ % ▪ cm, dm, m, mm ▪ hl ▪ in³, ft³, m³, ▪ l ▪ in, ft ▪ kg, t ▪ lb ▪ gal ▪ lgal
Factory setting	%

Line-numb

Write permission	Operators/Service engineers/Expert
-------------------------	------------------------------------

Description Enter the number of the current point in the table. Subsequent entries in "X-val" and "Y-val" relate to this point.

Input range 1...32

X-val

Write permission Operators/Service engineers/Expert

Description Enter the X-value (level before linearization) for the specific point in the table and confirm.

Note

- If "Lin. mode" = "Manual", the level value must be entered.
- If "Lin. mode" = "Semiautomatic", the level value is displayed and must be confirmed by entering the paired Y-value.

Y-value

Ceramic

Write permission Operators/Service engineers/Expert

Description Enter the Y-value (value after linearization) for the specific point in the table. The unit is determined by "Unit after lin.".

Note The linearization table must be monotonic (increasing or decreasing).

Edit table

Write permission Operators/Service engineers/Expert

Description Select the function for entering the table.

Options

- Next point: Enter the next point.
- Current point: Stay on the current point to correct a mistake, for example.
- Last point: Skip back to the previous point to correct a mistake, for example.
- Insert point: Insert an additional point (see example below).
- Delete point: Delete the current point (see example below).

Example**Add point, in this case between the 4th and 5th point for example**

- Select point 5 via the "Line-numb" parameter.
- Select the "Insert point" option via the "Edit table" parameter.
- Point 5 is displayed for the "Line-numb" parameter. Enter new values for the "X-val" and "Y-val" parameters.

Delete point, in this case the 5th point for example

- Select point 5 via the "Line-numb" parameter.
- Select the "Delete point" option via the "Edit table" parameter.
- The 5th point is deleted. All of the following points are pushed up one number i.e. following deletion, the 6th point becomes Point 5.

Factory setting

Current point

Tank description

Write permission

Operators/Service engineers/Expert

Description

Enter tank description (max. 32 alphanumeric characters).

Tank content

Write permission

Operators/Service engineers/Expert

Description

Displays the level value after linearization.

14.9 Expert → Measurement → Sensor limits

LRL sensor

Write permission No write permissions. Parameter is read only.

Description Displays the lower-range limit of the sensor.

URL sensor

Write permission No write permissions. Parameter is read only.

Description Displays the upper-range limit of the sensor.

14.10 Expert → Measurement → Sensor trim

Lo trim measured

Write permission No write permissions. Parameter is read only.

Description Displays the reference pressure present to be accepted for the lower calibration point.

Hi trim measured

Write permission No write permissions. Parameter is read only.

Description Displays the reference pressure present to be accepted for the upper calibration point.

Lo sensor trim

Write permission No write permissions. Parameter is read only.

Description Sensor module recalibration by entering a target pressure while simultaneously and automatically accepting a reference pressure present for the lower calibration point.

Hi sensor trim

Write permission No write permissions. Parameter is read only.

Description Sensor module recalibration by entering a target pressure while simultaneously and automatically accepting a reference pressure present for the upper calibration point.

14.11 Expert → Output → Current output

Output current

Write permission Operators/Service engineers/Expert

Description Displays the current current value.

Alarm behav. P

Write permission Operators/Service engineers/Expert

Description Behavior of current output if sensor module limits are exceeded or not reached.

Options

- Warning
The device continues to measure. An error message is displayed.
- Alarm
The output signal assumes a value that can be specified by the "Output fail mode" function.

Factory setting Warning

Output fail mode

Write permission Operators/Service engineers/Expert

Description Select Output fail mode. In the event of an alarm, the current assumes the current value specified with this parameter.

Options

- Max: can be set from 21 to 23 mA, see also "High alarm curr."
- Hold: last measured value is held.
- Min: 3.6 mA

Factory setting Max (22 mA)

High alarm curr.

Write permission Operators/Service engineers/Expert

Description Enter the current value for maximum alarm current. See also "Output fail mode".

Input range 21 to 23 mA

Factory setting 22 mA

Set min. current

Write permission Operators/Service engineers/Expert

Description Enter lower current limit.
Some switching units accept no current smaller than 4.0 mA.

Options ■ 3.8 mA
 ■ 4.0 mA

Factory setting 3.8 mA

Get LRV

Write permission Operators/Service engineers/Expert

Description Set the lower-range value – reference pressure is present at the device. The pressure for the lower current value (4 mA) is present at the device. Use the "Confirm" option to assign the lower current value to the applied pressure value.

Prerequisite: Pressure measuring mode

Options ■ Cancel
 ■ Confirm

Factory setting Cancel

Set LRV

Write permission Operators/Service engineers/Expert

Description Set the pressure value, level or content for the lower current value (4 mA).





Factory setting ■ 0.0 % in Level measuring mode
 ■ 0.0 mbar/bar or in accordance with ordering information in Pressure measuring mode

Get URV (pressure measuring mode)

Write permission Operators/Service engineers/Expert

Description	Set the upper-range value – reference pressure is present at the device. The pressure for the upper current value (20 mA) is present at the device. Use the "Confirm" option to assign the applied pressure value to the upper current value.
Prerequisite:	Pressure measuring mode
Options	<ul style="list-style-type: none"> ■ Cancel ■ Confirm
Factory setting	Cancel

Set URV

Navigation	  Setup → Set URV   Setup → Extended setup → Current output → Set URV
Write permission	Operators/Service engineers/Expert
Description	Set the pressure value, level or content for the upper current value (20 mA).
Factory setting	<ul style="list-style-type: none"> ■ 100.0 % in Level measuring mode ■ URL Sensor or according to ordering information in Pressure measuring mode

Start-up current

Write permission	Service engineers/Expert
Description	Entry of the start current. This setting also applies in HART multidrop mode.
Options	<ul style="list-style-type: none"> ■ 12 mA ■ Max alarm (22 mA, cannot be set)
Factory setting	12 mA

Curr. trim 4mA

Write permission	Service engineers/Expert
Description	Enter the pressure value for the lower point (4 mA) of the current partial regression lines. Using this parameter and "Curr. trim 20 mA", you can adapt the current output to the transmission conditions.

Options	Carry out the current trim for the lower point as follows. <ul style="list-style-type: none"> ■ Select the "Current" option in the "Simulation mode" parameter. ■ In the "Sim current" parameter, configure the "4 mA value". ■ Enter the current value measured using the switching unit in the "Curr. trim 4mA" parameter.
Input range	Measured current ± 0.2 mA
Factory setting	4 mA
<hr/>	
Curr. trim 20mA	
<hr/>	
Write permission	Service engineers/Expert
Description	Enter the pressure value for the upper point (20 mA) of the current partial regression lines. Using this parameter and "Curr. Trim 4 mA", you can adapt the current output to the transmission conditions.
Options	Carry out the current trim for the upper point as follows: <ul style="list-style-type: none"> ■ Select the "Current" option in the "Simulation mode" parameter. ■ In the "Sim current" parameter, configure the value "20 mA". ■ Enter the current value measured using the switching unit in the "Curr. trim 20mA" parameter.
Input range	Measured current ± 1 mA
Factory setting	20 mA
<hr/>	
Offset trim 4mA	
<hr/>	
Write permission	Service engineers/Expert
Description	Display/enter the difference between 4 mA and the value entered for the parameter "Curr. trim 4mA".
Factory setting	0
<hr/>	
Offset trim 20mA	
<hr/>	
Write permission	Service engineers/Expert
Description	Display/enter the difference between 20 mA and the value entered for the parameter "Curr. trim 20mA".
Factory setting	0

14.12 Expert → Communication → HART config.

Burst mode

Write permission	Service engineers/Expert
Description	Switching burst mode on and off.
Options	<ul style="list-style-type: none"> ▪ On ▪ Off
Factory setting	Off

Burst option

Write permission	Service engineers/Expert
Description	You can use this parameter to define which command is sent to the master.
Options	<ul style="list-style-type: none"> ▪ 1 (HART command 1) ▪ 2 (HART command 2) ▪ 3 (HART command 3) ▪ 9 (HART command 9) ▪ 33 (HART command 33)
Factory setting	1 (HART command 1)

Current mode

Write permission	Service engineers/Expert
Description	Configure current mode for HART communication.
Options	<ul style="list-style-type: none"> ▪ Signaling Measured value transmission by the current value ▪ Fixed Fixed current 4.0 mA (multidrop mode) (Measured value transmission via HART digital communication only)
Factory setting	Signaling

Bus address

Write permission	Service engineers/Expert
Description	Use this function to enter the address via which a data exchange is to take place via HART protocol. (HART 5.0 master: Range 0 to 15, where address = 0 calls up the "Signaling" setting; HART 6.0 master: Range 0 to 63)
Factory setting	0

Preamble number

Write permission	Service engineers/Expert
Description	Use this function to enter the number of preambles in the HART protocol. (Synchronization of the modem components along a transmission path, each modem component could "swallow" one byte, at least 2 bytes must be the preamble.)
Input range	2...20
Factory setting	5

14.13 Expert → Communication → HART info

Device type

Write permission No write permissions. Parameter is read only.

Description Display of the numerical ID of the device
Waterpilot FMX21: 36

Device revision

Write permission No write permissions. Parameter is read only.

Description Display of device revision (e.g. 1)

Manufacturer ID

Write permission No write permissions. Parameter is read only.

Description Displays the HART manufacturer ID in a decimal digit format.
Here: 17 (Endress+Hauser)

HART version

Write permission No write permissions. Parameter is read only.

Description Displays HART version .
Waterpilot FMX21: 6

Description

Write permission Service engineers/Expert

Description Enter measuring point description (max. 16 alphanumeric characters).

HART message

Write permission	Service engineers/Expert
Description	Enter message (max. 32 alphanumeric characters). Upon request from the master, this message is sent via the HART protocol.

HART date

Write permission	Service engineers/Expert
Description	Enter the date of the last configuration change.
Factory setting	DD/MM/YY (date of the final test)

14.14 Expert → Communication → HART output

Primary value is	
Write permission	No write permissions. Parameter is read only.
Description	Indicates which measured value is transmitted via the HART protocol as the primary process value.
Factory setting	Depending on the selected measuring mode, the following measured values can be displayed: <ul style="list-style-type: none"> ■ "Pressure" measuring mode: "Meas. pressure" ■ "Level" measuring mode, Lin. mode "Linear": "Level before Lin" ■ "Level" measuring mode, Lin. mode "Activate table": "Tank content"
Primary value	
Write permission	No write permissions. Parameter is read only.
Description	The primary value is displayed.
Secondary val.is	
Write permission	No write permissions. Parameter is read only.
Description	Indicates which measured value is transmitted via the HART protocol as the secondary process value. The process value is configured via HART command 51.
Factory setting	<ul style="list-style-type: none"> ■ "Pressure" measuring mode: "Corrected press." ■ "Level" measuring mode, "Linear" lin. mode: "Meas. pressure" ■ "Level" measuring mode, Lin. mode "Activate table": "Level before linearization"
Display	Depending on the selected measuring mode, the following measured values can be displayed: <ul style="list-style-type: none"> ■ "Meas. pressure" ■ "Sensor pressure" ■ "Corrected press." ■ "Pressure after damping" ■ "Sensor temp." ■ "Level before Lin" ■ "Tank content" ■ "Process density" (corrected)
Secondary value	

Write permission No write permissions. Parameter is read only.

Description The secondary value is displayed.

Third value is

Write permission No write permissions. Parameter is read only.

Description Indicates which measured value is transmitted via the HART protocol as the third process value. The process value is configured via HART command 51.

Factory setting

- "Pressure" measuring mode: "Sensor pressure"
- "Level" measuring mode, "Linear" lin. mode: "Corrected press."
- "Level" measuring mode, "Activate table" lin. mode: "Meas. pressure"

Display Depending on the selected measuring mode, the following measured values can be displayed:

- "Meas. pressure"
- "Sensor pressure"
- "Corrected press."
- "Pressure after damping"
- "Sensor temp."
- "Level before Lin"
- "Tank content"
- "Process density" (corrected)

Third value is

Write permission No write permissions. Parameter is read only.

Description The third value is displayed.

4th value is

Write permission No write permissions. Parameter is read only.

Description Indicates which measured value is transmitted via the HART protocol as the fourth process value. The process value is configured via HART command 51.

Factory setting

- "Pressure" measuring mode: "Sensor temp"
- "Level" measuring mode, "Linear" lin. mode: "Sensor temp."
- "Level" measuring mode, "Activate table" lin. mode: "Sensor temp."

Display Depending on the selected measuring mode, the following measured values can be displayed:

- "Meas. pressure"
- "Sensor pressure"
- "Corrected press."
- "Pressure after damping"
- "Sensor temp."
- "Level before Lin"
- "Tank content"
- "Process density" (corrected)

4th value

Write permission No write permissions. Parameter is read only.

Description The fourth value is displayed.

14.15 Expert → Communication → HART input

HART input value

Write permission No write permissions. Parameter is read only.

Description Display of the HART input value

HART input stat.

Write permission No write permissions. Parameter is read only.

Description Display of the HART input status
Bad / Uncertain / Good

HART input unit

Write permission No write permissions. Parameter is read only.

Description Display of the unit for the HART input value.

Display

- Unknown
- mbar, bar
- mmH₂O, ftH₂O, inH₂O
- Pa, hPa, kPa, MPa
- psi
- mmHg, inHg
- Torr
- g/cm², kg/cm²
- lb/ft²
- atm
- °C, °F, K, R

Factory setting Unknown

HART input form.

Write permission Operators/Service engineers/Expert

Description Number of decimal places of the displayed input value.

Options

- x.x
- x.xx
- x.xxx
- x.xxxx
- x.xxxxx

Factory setting

x.x

14.16 Expert → Application

Electr. Delta P

Write permission

Description Switching off, switching on the Electr. Delta P application with external or constant value.

Options

- Off
- External value
- Constant

Factory setting Off

Fixed ext. value

Write permission

Description Use this function to enter the constant value. The value refers to "HART input unit"

Factory setting 0.0

Auto dens. corr.

Write permission

Description For switching the auto dens. corr. application on or off with an external or internal temperature value.
 Before performing a calibration (dry or wet), auto-density compensation must be switched on if this function is to be used. As soon as "Auto dens. corr." is switched on, the field for entering the "Process density" and "Adjust density" is disabled.
 The calibration density remains the last value until it is overwritten by a calibration. The process density remains the last value until it is overwritten when the system recalculates the value.
 Automatic density compensation is performed for the 0 to 70 °C (32 to 158 °F) temperature range. The density values for water are used for this density compensation.

Prerequisite Level mode

Options

- Off
- Sensor temperature
- External value (only if Electr. Delta P option is off or constant)

Factory setting

- Off
- On (if the option "IC" was selected in the "Service" order code when ordering)

14.17 Expert → Diagnosis

Diagnostic code

Write permission No write permissions. Parameter is read only.

Description Displays the diagnostic message with the highest priority currently present.

Last diag. code

Write permission No write permissions. Parameter is read only.

Description Displays the last diagnostic message that occurred and was rectified.

Note

- Digital communication: the last message is displayed.
- Use the "Reset logbook" parameter to clear the messages listed in the parameter "Last diag. code".

Reset logbook

Write permission Service engineers/Expert

Description Use this parameter to reset all messages of the parameter "Last diag. code" and the event logbook "Last diag. 1" to "Last diag. 10".

Options

- Cancel
- Confirm

Factory setting Cancel

Min. meas. press.

Write permission No write permissions. Parameter is read only.

Description Displays the lowest pressure value measured (peakhold indicator). You can reset this indicator by means of the "Reset peakhold" parameter.

Max. meas. press.

Write permission No write permissions. Parameter is read only.

Description Displays the highest pressure value measured (peakhold indicator). You can reset this indicator by means of the "Reset peakhold" parameter.

Reset peakhold

Write permission Service engineers/Expert

Description You can reset the "Min. meas. press." and "Max. meas. press." indicators with this parameter.

Options

- Cancel
- Confirm

Factory setting Cancel

Operating hours

Write permission No write permissions. Parameter is read only.

Description Displays the hours of operation. This parameter cannot be reset.

Config. recorder

Write permission Operators/Service engineers/Expert

Description Displays the configuration counter.
This counter is increased by one every time a parameter or group is changed. The counter counts up to 65535 and then starts again at zero.

14.18 Expert → Diagnosis → Diagnostic list

Diagnostic 1 (075)
Diagnostic 2 (076)
Diagnostic 3 (077)
Diagnostic 4 (078)
Diagnostic 5 (079)
Diagnostic 6 (080)
Diagnostic 7 (081)
Diagnostic 8 (082)
Diagnostic 9 (083)
Diagnostic 10 (084)

Navigation

 Diagnosis → Diagnostic list

Write permission

No write permissions. Parameter is read only.

Description

This parameter contains up to ten diagnosis messages that are currently pending, arranged in order of priority.

14.19 Expert → Diagnosis → Event logbook

Last diag. 1 (085)
Last diag. 2 (086)
Last diag. 3 (087)
Last diag. 4 (088)
Last diag. 5 (089)
Last diag. 6 (090)
Last diag. 7 (091)
Last diag. 8 (092)
Last diag. 9 (093)
Last diag. 10 (094)

Navigation

 Diagnosis → Event logbook

Write permission

No write permissions. Parameter is read only.

Description

This parameter contains the last 10 diagnosis messages to occur and be rectified. They can be reset using the "Reset logbook" parameter.
Errors which have occurred multiple times are displayed once only.
Errors may also appear multiple times if another error has occurred in the meantime. The messages are displayed in chronological order.

14.20 Expert → Diagnosis → Simulation

Simulation mode

Write permission	Operators/Service engineers/Expert
Description	Switch on simulation and select the simulation mode. When changing the measuring mode or the "Lin. mode" level type or when the device is restarted, any simulation that may be running is switched off.
Options	<ul style="list-style-type: none"> ▪ None ▪ Pressure → see this table, "Sim. pressure" parameter ▪ Level, → see this table, "Sim. level" parameter ▪ Tank content, → see this table, "Sim. tank cont." parameter ▪ Current, → see this table, "Sim. current" parameter ▪ Alarm/warning, → see this table, "Sim. error no."
Factory setting	None

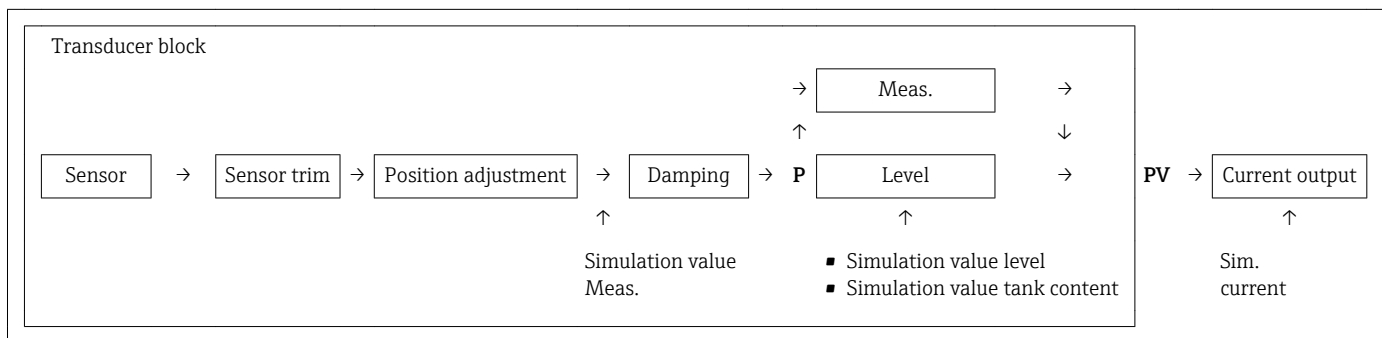

Sim. pressure

Write permission	Operators/Service engineers/Expert
Description	Enter the simulation value. See also "Simulation mode".
Prerequisite	"Simulation mode" = Pressure
Value at switch-on	Current pressure measured value

Sim. level

Write permission	Operators/Service engineers/Expert
Description	Enter the simulation value. See also "Simulation mode".

Prerequisite "Measuring mode" = Level and "Simulation mode" = Level

Value at switch-on Current level measured value

Sim. tank cont.

Write permission Operators/Service engineers/Expert

Description Enter the simulation value. See also "Simulation mode".

Prerequisite "Measuring Mode" = level, Lin mode "Activate table" and "Simulation Mode" = Tank content

Value at switch-on Current tank content

Sim. current

Write permission Operators/Service engineers/Expert

Description Enter the simulation value. See also "Simulation mode".

Prerequisite "Simulation Mode" = Current value

Value at switch-on Current current value

Sim. alarm/warning

Write permission Operators/Service engineers/Expert

Description Enter the simulation value. See also "Simulation mode".

Prerequisite "Simulation Mode" = Alarm/Warning

Factory setting: 484 (Simulation active)

15 Accessories

15.1 Suspension clamp

- For easy installation of the FMX21, Endress+Hauser offers a mounting clamp .
- Material: 316L (1.4404) and fiber-glass reinforced PA (polyamide)
- Order number: 52006151
- Ordering information: Product Configurator order code for "Accessories enclosed"

15.2 Terminal box

- Terminal box IP66/IP67 with GORE-TEX® filter incl. 3 installed terminals The terminal box is also suitable for installing a TMT182 temperature head transmitter or for four additional terminals (order no.: 52008938)
- Order number: 52006152 ordering information: Product Configurator order code for "Accessories enclosed", option "PS"

i The terminal box is not designed for the FMX21 with type of protection Ex nA in hazardous areas. If the terminal box is used in a hazardous area, the Safety Instructions of the relevant device must be observed, as well as the applicable regulations for explosion protection.

15.3 Additional weight

15.3.1 For FMX21 with external diameter of 22 mm (0.87 in) or 29 mm (1.14 in)

- Endress+Hauser offers additional weights to prevent sideways movement that results in measuring errors, or to make it easier to lower the device in a guide tube. You can screw several weights together. The weights are screwed directly onto the FMX21. For the FMX21 with external diameter of 29 mm (1.14 in), a maximum of 5 weights may be screwed on. In conjunction with the Ex nA approval, a maximum of one additional weight is permitted for the FMX21 with external diameter of 29 mm (1.14 in).
- Material: 316L (1.4435)
- Weight: 300 g (10.581 oz)
- Order number: 52006153 Ordering information: Product Configurator order code for "Accessories enclosed", option "PU"

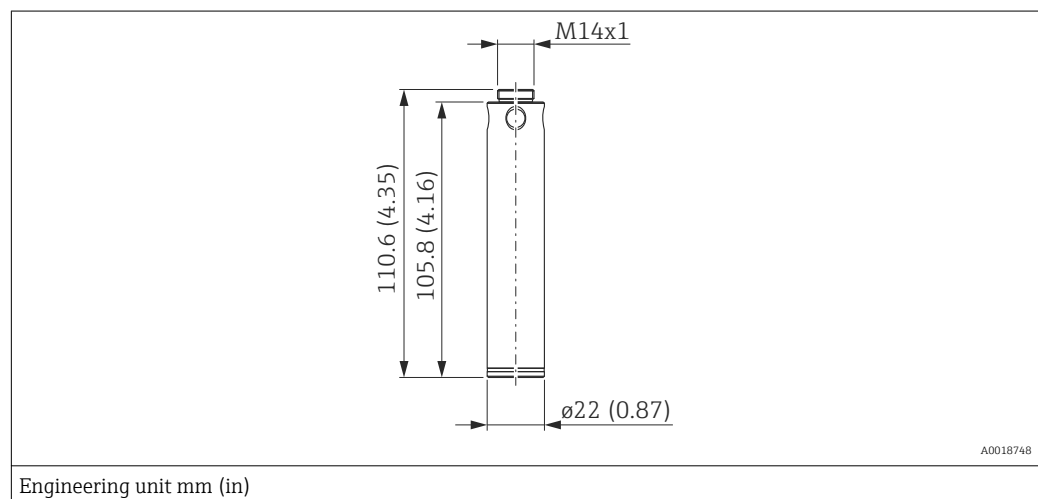

15.4 Temperature head transmitter TMT182 (4 to 20 mA HART)

- Temperature head transmitter 2-wire, configured for a measuring range of -20 to $+80$ °C (-4 to $+158$ °F). This configuration offers a temperature range of 100 K which can be easily mapped. Please note that the Pt100 resistance thermometer is suitable for a temperature range of -10 to $+70$ °C (-14 to $+176$ °F) -10 to $+70$ °C.
- Order no.: 51001023 ordering information: Product Configurator order code for "Accessories enclosed", option "PT"

 The TMT182 temperature head transmitter is not designed for use in hazardous areas incl. CSA GP.

15.5 Pt-100 resistance thermometer

Ordering information: Product Configurator order code for "Accessories mounted", option "NB"

15.6 Cable mounting screws

Endress+Hauser offers a cable mounting screw for easy installation of the FMX21 and to seal the measuring aperture.

- Order number for cable mounting screw:
 - 52008264 (G 1½" A) Ordering information: Product Configurator order code for "Accessories enclosed", option "PQ"
 - 52009311 (NPT 1½") Ordering information: Product Configurator order code for "Accessories enclosed" option "PR"
- Material

15.7 Terminals

- Four terminals in strip for terminal box, suitable for cable cross-section: 0.08 to 2.5 mm² (28 to 14 AWG)
- Order number: 52008938

 The 4-terminal strip is not designed for use in hazardous areas incl. CSA GP.

15.8 Cable shortening kit

- The cable shortening kit is used to shorten a cable easily and professionally.
- Order number: 71222671, Ordering information: Product Configurator order code for "Accessories enclosed", option "PW" Associated documentation SD00552P/00/A6.

 The cable shortening kit is not designed for the FMX21 with FM/CSA approval.

15.9 Cable marking

- To make installation easier, Endress+Hauser marks the extension cable if a customer-specific length has been ordered
- Cable marking tolerance (distance to lower end of level probe):
 - Cable length < 5 m (16 ft): ± 17.5 mm (0.69 in)
 - Cable length > 5 m (16 ft): ± 0.2 %
- Material: PET, stick-on label: acrylic
- Immunity to temperature change: -30 to $+100$ °C (-22 to $+212$ °F)

NOTICE

The marking is used exclusively for installation purposes.

- ▶ The mark must be thoroughly removed without trace in the case of devices with drinking water approval. The extension cable must not be damaged in the process.

i Not for use of the FMX21 in hazardous areas.

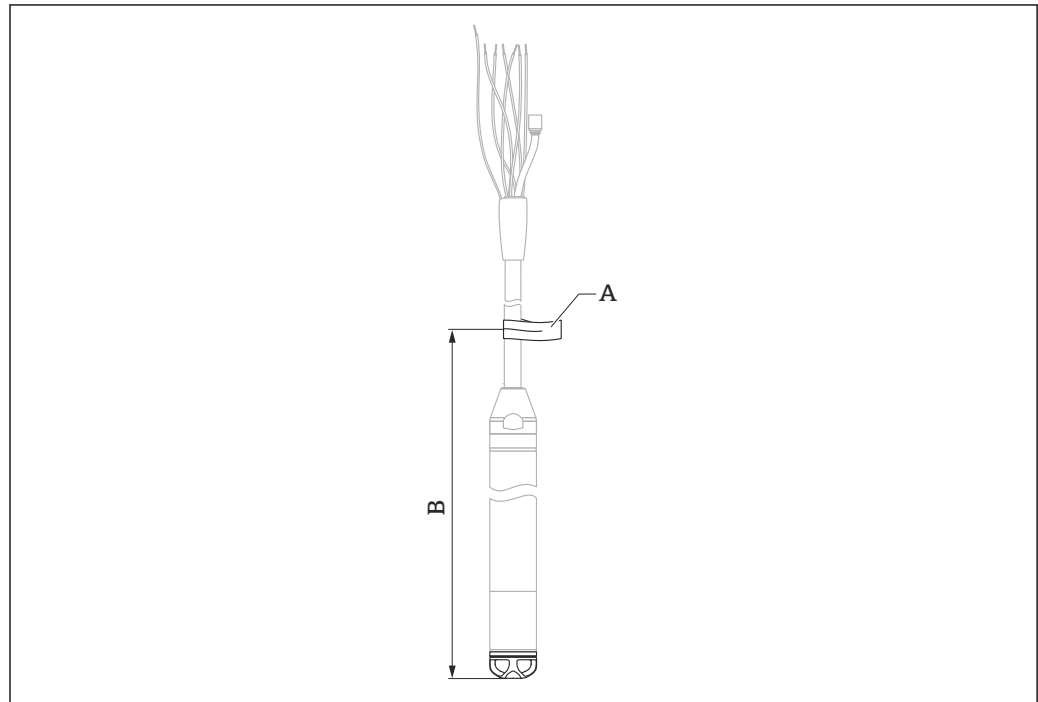

A0018792

- A Cable marking
B Cable marking tolerance

15.10 Testing adapter

15.10.1 For FMX21 with external diameter of 22 mm (0.87 in) or 29 mm (1.14 in)

- Endress+Hauser offers a testing adapter to ease function-testing of the level probes.
- Observe the maximum pressure for compressed air hose and maximum overload for level probe → 122
- Maximum pressure for the quick coupling piece provided: 10 bar (145 psi)
- Adapter material: 304 (1.4301)
- Material of quick coupling piece: anodized aluminum
- Weight: 39 g (1.376 oz)
- Order number 52011868

Ordering information: Product Configurator order code for "Accessories enclosed", option "PV"

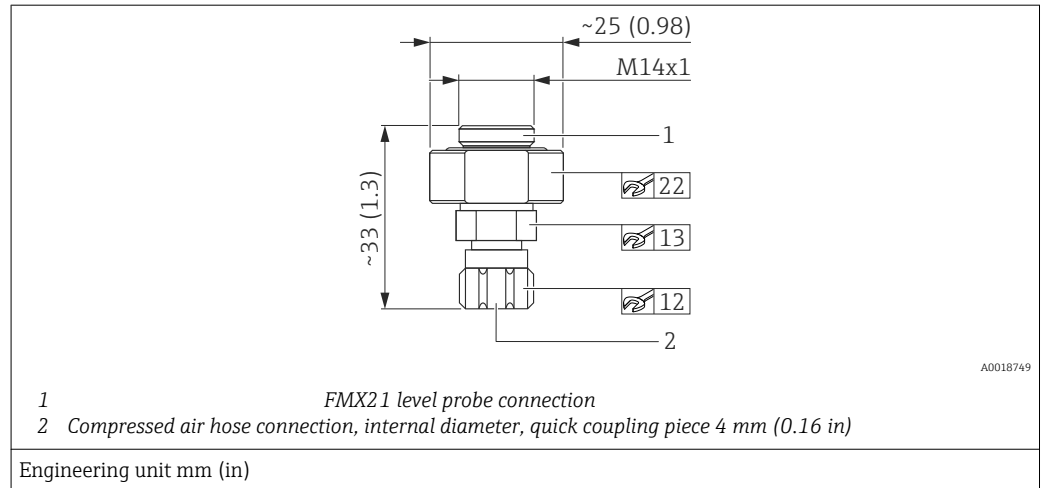

15.10.2 For FMX21 with external diameter of 42 mm (1.65 in)

Order number: 71110310

16 Technical data

16.1 Input

16.1.1 Measured variable

FMX21 + Pt100 (optional)

- Hydrostatic pressure of a liquid
- Pt100: Temperature

TMT182 temperature head transmitter (optional)

Temperature

16.1.2 Measuring range

- Customer-specific measuring ranges or calibration that has been preset in the factory
- Temperature measurement of -10 to +70 °C (+14 to +158 °F) with Pt100 (optional)

Relative pressure

Sensor measuring range [bar (psi)]	Lowest calibratable span ¹⁾ [bar (psi)]	Vacuum resistance [bar _{abs} (psi _{abs})]	Option ²⁾
0.1 (1.5)	0.01 (0.15)	0.3 (4.5)	1C
0.2 (3.0)	0.02 (0.3)	0.3 (4.5)	1D
0.4 (6.0)	0.04 (1.0)	0	1F
0.6 (9.0)	0.06 (1.0)	0	1G
1.0 (15.0)	0.1 (1.5)	0	1H
2.0 (30.0)	0.2 (3.0)	0	1K
4.0 (60.0)	0.4 (6.0)	0	1M
10.0 (150) ³⁾	1.0 (15)	0	1P
20.0 (300) ³⁾	2.0 (30)	0	1Q

1) Recommended maximum turn down: 100:1. Highest turn down that can be preset at the factory: 20:1, higher available on request.

2) Product Configurator order code for "Sensor range"

3) These measuring ranges are not available for the special version with plastic insulation, external diameter of 29 mm (1.14 in).

Absolute pressure

Sensor measuring range [bar (psi)]	Lowest calibratable span ¹⁾ [bar (psi)]	Vacuum resistance [bar _{abs} (psi _{abs})]	Option ²⁾
2.0 (30.0)	0.2 (3.0)	0	2K
4.0 (60.0)	0.4 (6.0)	0	2M

Sensor measuring range [bar (psi)]	Lowest calibratable span ¹⁾ [bar (psi)]	Vacuum resistance [bar _{abs} (psi _{abs})]	Option ²⁾
10.0 (150) ³⁾	1.0 (15)	0	2P
20.0 (300) ³⁾	2.0 (30)	0	2Q

- 1) Recommended maximum turn down: 100:1. Highest turn down that can be preset at the factory: 20:1, higher available on request.
- 2) Product Configurator order code for "Sensor range"
- 3) These measuring ranges are not available for the special version with plastic insulation, external diameter of 29 mm (1.14 in).

16.1.3 Input signal

FMX21 + Pt100 (optional)

- Change in capacitance
- Pt100: Change in resistance

TMT182 temperature head transmitter (optional)

Pt100 resistance signal, 4 wire

16.2 Output

16.2.1 Output signal

FMX21 + Pt100 (optional)

- 4 to 20 mA with superimposed digital communication protocol HART 6.0, 2-wire for hydrostatic pressure measured value. Ordering information: Product Configurator order code for "output", option "2"
- Pt100: temperature-dependent resistance value

TMT182 temperature head transmitter (optional)

4 to 20 mA with superimposed digital communication protocol HART 5.0 for temperature measured value, 2-wire

16.2.2 Signal range

3.8 mA to 20.5 mA

16.2.3 Output signal

FMX21 + Pt100 (optional)

4 to 20 mA HART.

Options:

- Max. alarm (factory setting 22mA): can be set from 21 to 23 mA
- Hold measured value: last measured value is held
- Min. alarm: 3.6 mA

TMT182 temperature head transmitter (optional)

Options:

- Max. alarm ≥ 21.0 mA
- Min. alarm ≤ 3.6 mA

16.2.4 Maximum load

The maximum load resistance depends on the supply voltage (U) and must be determined individually for each current loop, see formula and diagrams for FMX21 and temperature head transmitter.

The total resistance resulting from the resistances of the connected devices, the connecting cable and, where applicable, the resistance of the extension cable may not exceed the load resistance value.

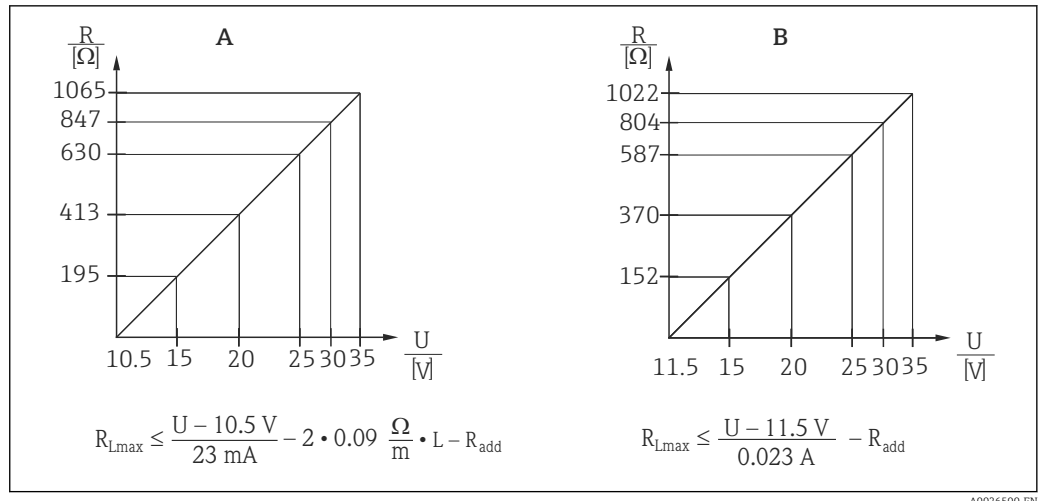

A FMX21 load chart for estimating the load resistance. Additional resistances, such as the resistance of the extension cable, have to be subtracted from the value calculated as shown in the equation.

B Load diagram for TMT182 temperature head transmitter for estimating the load resistance. Additional resistances must be subtracted from the value calculated as shown in the equation

R_{Lmax} Max. load resistance [Ω]

R_{add} Additional resistances, such as resistance of the evaluation unit and/or display unit, cable resistance [Ω]

U Supply voltage [V]

L Basic length of extension cable [m] (cable resistance per wire 0.09 Ω/m)



- When using the measuring device in a hazardous area, the relevant national standards and regulations as well as the Safety Instructions or installation or control drawings (XA) must be adhered to.
- When operating via a handheld terminal or via a PC with an operating program, a minimum communication resistance of 250 Ω must be taken into account.

16.2.5 Protocol-specific data

Manufacturer ID	17 (11 hex)
Device type code	25 (19 hex)
Device revision	01 (01 hex) - SW version 01.00.zz
HART specification	6
DD revision	01
Device description files (DTM, DD)	Information and files under: <ul style="list-style-type: none"> ▪ www.endress.com ▪ www.hartcomm.org
HART load	Min. 250 Ω

<p>HART device variables</p>	<p>The dynamic variables SV, TV and QV may be assigned to any device variable: Standard process values for SV, TV (second and third device variable) are dependent on the measuring mode:</p> <ul style="list-style-type: none"> ■ Meas. ■ Level <p>Standard process value for QV (fourth device variable) is the sensor temperature: Temperature</p> <p>Measured values for PV (first device variable) are dependent on the measuring mode:</p> <ul style="list-style-type: none"> ■ Meas. ■ Level ■ Tank content
<p>Supported functions</p>	<ul style="list-style-type: none"> ■ Burst mode ■ Additional transmitter status ■ Device locking ■ Alternative measuring modes ■ Catch variable ■ Long tag

16.3 Performance characteristics

16.3.1 Reference operating conditions

FMX21 + Pt100 (optional)

- As per IEC 60770
- Ambient temperature T_U = constant, in the range of +21 to +33 °C (+70 to +91 °F)
- Humidity φ = constant, in the range of 20 to 80 % rH
- Ambient pressure p_U = constant, in the range of 860 to 1060 mbar (12.47 to 15.37 psi)
- Position of measuring cell constant, vertical in the range of $\pm 1^\circ$
- Supply voltage constant: 21 V DC to 27 V DC
- Load with HART: 250 Ω
- Pt100: DIN EN 60770, $T_U = +25$ °C (+77 °F)

TMT182 temperature head transmitter (optional)

Calibration temperature +25 °C (+77 °F) ± 5 K

16.3.2 Reference accuracy

FMX21 + Pt100 (optional)

The reference accuracy comprises the non-linearity after limit point configuration, hysteresis and non-reproducibility in accordance IEC 60770.

Standard version:

Setting ± 0.2 %

- to TD 5:1: < 0.2 % of set span
- from TD 5:1 to TD 20:1 $\pm (0.02 \times TD + 0.1)$

Ordering information: Product Configurator order code for "Reference accuracy", option "G"

Platinum version:

- Setting ± 0.1 % (optional)
 - to TD 5:1: < 0.1 % of set span
 - from TD 5:1 to TD 20:1 $\pm (0.02 \times TD)$
- Class B as per DIN EN 60751
Pt100: max. ± 1 K

Ordering information: Product Configurator order code for "Reference accuracy" option "D"

TMT182 temperature head transmitter (optional)

- ± 0.2 K
- With Pt100: max. ± 0.9 K

16.3.3 Resolution

Current output: 1 μ A

Reading cycle

HART commands: on average 2 to 3 per second

16.3.4 Long-term stability

FMX21 + Pt100 (optional)

- ≤ 0.1 % of URL/year
- ≤ 0.25 % of URL/5 years

TMT182 temperature head transmitter (optional)

≤ 0.1 K per year

16.3.5 Influence of medium temperature

- Thermal change in the zero output and the output span:
 - 0 to +30 °C (+32 to +86 °F): $< (0.15 + 0.15 \times TD)\%$
 - 10 to +70 °C (+14 to +158 °F): $< (0.4 + 0.4 \times TD)\%$
- Temperature coefficient (T_K) of the zero output and the output span
 - 10 to +70 °C (+14 to +158 °F): 0.1 % / 10 K URL

16.3.6 Warm-up period

FMX21 + Pt100 (optional)

- FMX21: < 6 s
- Pt100: 20 m

TMT182 temperature head transmitter (optional)

4 s

16.3.7 Response time

FMX21 + Pt100 (optional)

- FMX21: 400 ms (T90 time), 500 ms (T99 time)
- Pt100: 160 s (T90 time), 300 s (T99 time)

16.4 Environment

16.4.1 Ambient temperature range

FMX21 + Pt100 (optional)

- With external diameter of 22 mm (0.87 in) and 42 mm (1.65 in):
-10 to +70 °C (+14 to +158 °F) (= medium temperature)
- With external diameter of 29 mm (1.14 in):
0 to +50 °C (+32 to +122 °F) (= medium temperature)

Cable

(when mounted in a fixed position)

- With PE: -30 to +70 °C (-22 to +158 °F)
- With FEP: -40 to +70 °C (-40 to +158 °F)
- With PUR: -40 to +70 °C (-40 to +158 °F)

Terminal box

-40 to +80 °C (-40 to +176 °F)

TMT182 temperature head transmitter (optional)

-40 to +85 °C (-40 to +185 °F)

16.4.2 Storage temperature range

FMX21 + Pt100 (optional)

-40 to +80 °C (-40 to +176 °F) (= medium temperature)

Cable

(when mounted in a fixed position)

- With PE: -30 to +70 °C (-22 to +158 °F)
- With FEP: -30 to +80 °C (-40 to +158 °F)
- With PUR: -40 to +80 °C (-40 to +176 °F)

Terminal box

-40 to +80 °C (-40 to +176 °F)

TMT182 temperature head transmitter (optional)

-40 to +100 °C (-40 to +212 °F)

16.4.3 Degree of protection

FMX21 + Pt100 (optional)

IP68, permanently hermetically sealed at 20 bar (290 psi) (~200 m H₂O)

Terminal box (optional)

IP66, IP67

TMT182 temperature head transmitter (optional)

IP00, condensation permitted

16.4.4 Installation height as per IEC61010- 1Ed.3

Up to 2 000 m (6 600 ft) above MSL.

16.4.5 Electromagnetic compatibility (EMC)**FMX21 + Pt100 (optional)**

- EMC in accordance with all relevant requirements of EN 61326 series. For details, refer to the Declaration of Conformity.
- Maximum deviation: < 0.5 % of span

TMT182 temperature head transmitter (optional)

EMC in accordance with all relevant requirements of EN 61326 series. For details, refer to the Declaration of Conformity.

16.4.6 Overvoltage protection**FMX21 + Pt100 (optional)**

- Integrated overvoltage protection as per EN 61000-4-5 (500 V symmetrical/1000 V asymmetrical)
- Overvoltage protection ≥ 1.0 kV, external if necessary

TMT182 temperature head transmitter (optional)

Overvoltage protection external if necessary

16.5 Process

16.5.1 Medium temperature range

FMX21 + Pt100 (optional)

- With external diameter of 22 mm (0.87 in) and 42 mm (1.65 in):
-10 to +70 °C (+14 to +158 °F)
- With external diameter of 29 mm (1.14 in):
0 to +50 °C (+32 to +122 °F)

16.5.2 Medium temperature limit

FMX21 + Pt100 (optional)

With external diameter of 22 mm (0.87 in) and 42 mm (1.65 in):
-20 to +70 °C (-4 to +158 °F)

 In hazardous area incl. CSA GP, the medium temperature limit is
-10 to +70 °C (+14 to +158 °F).

With external diameter of 29 mm (1.14 in): 0 to +50 °C (+32 to +122 °F)

 The FMX21 may be operated in this temperature range. The specification can then be exceeded e.g. measuring accuracy

16.6 Additional technical data

See Technical Information:

Index

- 0 ... 9**
- 4th value 108
 - 4th value is 107
- A**
- Adjust density 91
 - Alarm behav. P 98
 - Application 8
 - Auto dens. corr. 111
- B**
- Burst Mode 102
 - Burst Option 102
 - Bus Address 102
- C**
- Calib. Offset 84
 - Calibration mode 89
 - CE mark (declaration of conformity) 9
 - Cleaning 70
 - Code definition 80
 - Config. counter 113
 - Configuration of a level measurement 43
 - Configuration of a pressure measurement 41
 - Configure language 39
 - Configure measuring mode 39
 - Configure pressure engineering unit 40
 - Configuring level measurement 43
 - Configuring pressure measurement 41
 - Corrected press. 87
 - Curr. trim 4mA 100
 - Curr. trim 20mA 101
 - Current Mode 102
 - Cust. tag number 81
- D**
- Damping 41, 84
 - Declaration of Conformity 9
 - Density correction 111
 - Density unit 91
 - Description 104
 - Designated use 8
 - Device replacement 71
 - Device revision 104
 - Device tag 81
 - Device type 104
 - Diagnosis
 - Symbols 64
 - Diagnostic 1 (075) 114
 - Diagnostic 2 (076) 114
 - Diagnostic 3 (077) 114
 - Diagnostic 4 (078) 114
 - Diagnostic 5 (079) 114
 - Diagnostic 6 (080) 114
 - Diagnostic 7 (081) 114
 - Diagnostic 8 (082) 114
 - Diagnostic 9 (083) 114
 - Diagnostic 10 (084) 114
 - Diagnostic code 112
 - Diagnostic event 64
 - Diagnostic events 64
 - Diagnostic message 64
- E**
- Edit table 94
 - Electr. Delta P 111
 - Electr.serial no 82
 - Empty calib. 89
 - Empty height 90
 - Empty pressure 89
 - ENP version 82
 - Enter reset code 83
 - Event text 64
 - Ext. order code 81
 - Exterior cleaning 70
- F**
- Firmware Version 81
 - Fixed ext. value 111
 - Full calib. 90
 - Full height 91
 - Full pressure 90
- G**
- Get LRV 99
 - Get URV (pressure measuring mode) 99
- H**
- HART Date 105
 - HART input form. 109
 - HART input stat. 109
 - HART input unit 109
 - HART input val. 109
 - HART Message 104
 - HART version 104
 - HART® protocol
 - Operating tools 36
 - Process variables 36
 - Version data for the device 36
 - Height unit 88
 - Hi trim measured 97
 - Hi Trim Sensor 97
- L**
- Last diag. 1 (085) 115
 - Last diag. 2 (086) 115
 - Last diag. 3 (087) 115
 - Last diag. 4 (088) 115
 - Last diag. 5 (089) 115
 - Last diag. 6 (090) 115
 - Last diag. 7 (091) 115
 - Last diag. 8 (092) 115
 - Last diag. 9 (093) 115
 - Last diag. 10 (094) 115

Last diag. code	112
Level before lin.	92
Level selection	88
Lin. mode	93
Line-numb.	93
Lo trim measured	97
Lo Trim Sensor	97
Local display	
see Diagnostic message	
see In alarm condition	
LRL sensor	96
M	
Maintenance	70
Manufacturer ID	104
Max. alarm curr.	98
Max. meas. press.	112
Media	8
Menu	
Overview	72, 75
Parameter description	80
Min. meas. press.	112
Mode	83
N	
Nameplate	13
O	
Offset trim 4mA	101
Offset trim 20mA	101
Operating hours	113
Operating menu	
Overview	72, 75
Parameter description	80
Operational safety	8
Operator code	80
Order Identifier	82
Output current	98
Output fail mode	98
Output unit	88
P	
Pos. zero adjust	84
Preamble Number	103
Press after damping	87
Press. eng. unit	85
Pressure measured	86
Primary value	106
Primary value is	106
Process density	92
Product safety	9
R	
Repair concept	71
Replacing a device	71
Reset Logbook	112
Reset Peakhold	113

S

Safety Instructions	
Basic	8
Safety Instructions (XA)	7
Secondary val. is	106
Secondary value	106
Sensor pressure	86
Sensor serial no.	82
Sensor temp.	85
Serial number	81
Set LRV	86, 99
Set min. current	99
Set URV	86, 100
Sim. alarm/warning	117
Sim. current	117
Sim. level	116
Sim. pressure	116
Sim. tank cont.	117
Simulation mode	116
Spare parts	71
Nameplate	71
Staff	
Requirements	8
Start-up current	100
Status signals	64

T

Tank content	95
Tank description	95
Temp. Eng. Unit	85
Third value	107
Third value is	107
Troubleshooting	64

U

Unit after lin.	93
URL sensor	96
Use of the measuring devices	
Borderline cases	8
Incorrect use	8
Using measuring device	
see Designated use	

W

W@M Device Viewer	71
Workplace safety	8

X

X-value	94
---------	----

Y

Y-value	94
---------	----



71293257

www.addresses.endress.com

TRANSCAT[®]
Trust in every measure

Visit us at Transcat.com 

sales@transcat.com 1.800.828.1470

Endress+Hauser 
People for Process Automation