

Operating Instructions

RIA452

Panel meter

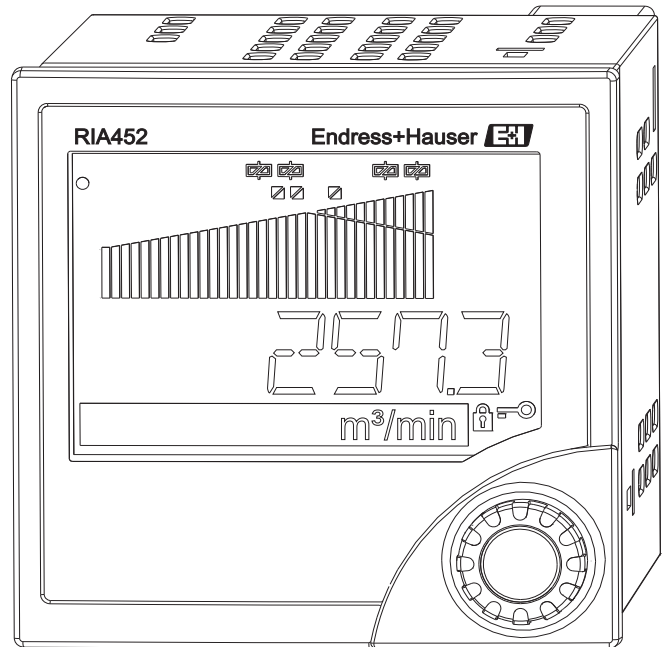

TRANSCAT[®]
Trust in every measure

Visit us at [Transcat.com](https://www.transcat.com) 

sales@transcat.com

1.800.828.1470

Endress+Hauser 

People for Process Automation

Brief overview

For rapid and easy commissioning:

Safety instructions	→ 4
▼	
Installation	→ 7
▼	
Wiring	→ 9
▼	
Display and operating elements	→ 17
▼	
Commissioning	→ 20
Device configuration - explanation and use of all the configurable device functions with the associated value ranges and settings.	

Block circuit diagram

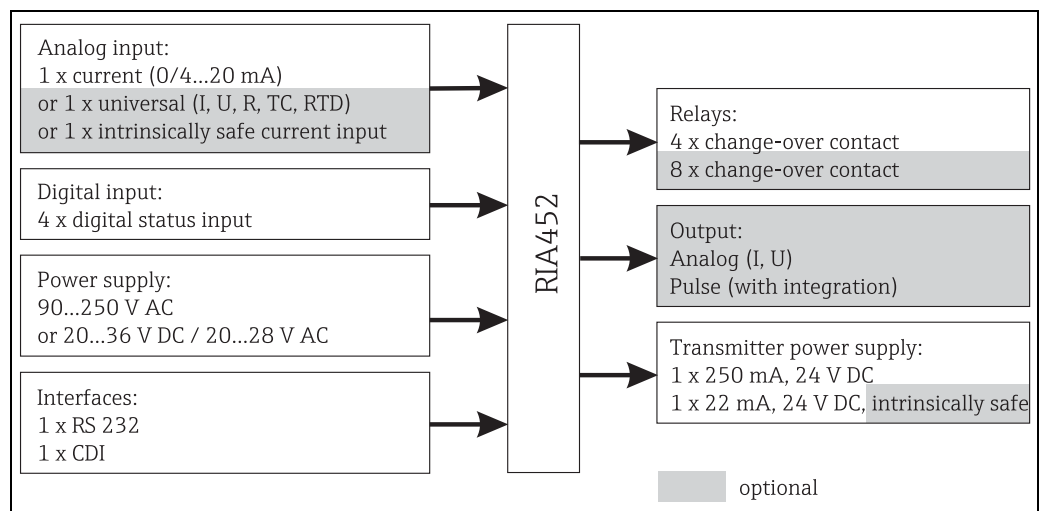

Fig. 1: RIA452 block circuit diagram

Table of Contents

1	Safety instructions	4	11	Appendix	55
1.1	Designated use	4	11.1	Flow conversion	55
1.2	Installation, commissioning and operation	4		Index	56
1.3	Operational safety	4			
1.4	Return	4			
1.5	Notes on safety conventions and icons	5			
2	Identification	6			
2.1	Device designation	6			
2.2	Scope of delivery	6			
2.3	Certificates and approvals	7			
3	Installation	7			
3.1	Installation	7			
3.2	Installation instructions	7			
4	Wiring	9			
4.1	Quick wiring guide	9			
4.2	Connecting the device	12			
4.3	Post-connection check	13			
5	Operation	14			
5.1	Quick operation guide	14			
5.2	Display and operating elements	17			
5.3	Local operation	18			
6	Commissioning	20			
6.1	Function check	20			
6.2	Switching on the measuring device	20			
6.3	Device configuration	20			
7	Maintenance	41			
8	Accessories	41			
9	Troubleshooting	42			
9.1	Troubleshooting instructions	42			
9.2	Process error messages	42			
9.3	Spare parts	43			
9.4	Return	44			
9.5	Disposal	44			
10	Technical data	45			
10.1	Input	45			
10.2	Output	49			
10.3	Installation	51			
10.4	Mechanical construction	52			
10.5	Human interface	53			
10.6	Certificates and approvals	54			
10.7	Documentation	54			

1 Safety instructions

Safe operation of the panel meter is only guaranteed if these Operating Instructions have been read and the safety instructions have been observed.

1.1 Designated use

The panel meter analyzes analog process variables and depicts them on its multicolored display. Processes can be monitored and controlled using analog and digital outputs and limit relays. The device provides the user with a wide range of software functions for this purpose.

Power can be supplied to 2-wire sensors with the integrated transmitter power supply.

- The device is seen as an associated electrical apparatus and may not be installed in hazardous areas.
- The manufacturer does not accept liability for damage caused by improper or non-designated use. The device may not be converted or modified in any way.
- The device is designed for installation in a panel and may only be operated in an installed state.

1.2 Installation, commissioning and operation

This device has been constructed to state-of-the-art technology and meets all applicable standards and EU directives. The device, however, can be a source of application-related danger if used improperly or other than intended.

Installation, wiring, commissioning and maintenance of the device must only be carried out by trained technical personnel. They must have read and understood these Operating Instructions and must follow the instructions they contain. The information in the electrical wiring diagrams (see Section 4 'Wiring') must be observed closely.

1.3 Operational safety

Technical improvement

The manufacturer reserves the right to adapt technical details to the most up-to-date technical developments without any special announcement. Contact your local sales center for information about the current state of and possible extensions to the Operating Instructions.

1.4 Return





For a return, e.g. in case of repair, the device must be sent in protective packaging. The original packaging offers the best protection. Repairs must only be carried out by your supplier's service organization.



Please enclose a note describing the fault and the application when sending the unit in for repair.

1.5 Notes on safety conventions and icons

Always refer to the safety instructions in these Operating Instructions labeled with the following symbols:

Symbol	Meaning
 <small>A0011190-EN</small>	WARNING! This symbol alerts you to a dangerous situation. Failure to avoid this situation can result in serious or fatal injury.
 <small>A0011191-EN</small>	CAUTION! This symbol alerts you to a dangerous situation. Failure to avoid this situation can result in minor or medium injury.
 <small>A0011192-EN</small>	NOTICE! This symbol contains information on procedures and other facts which do not result in personal injury.
	ESD - Electrostatic discharge Protect the terminals against electrostatic discharge. Failure to comply with this instruction can result in the destruction of parts or malfunction of the electronics.
 <small>A0011193</small>	Indicates additional information, Tip

2 Identification

2.1 Device designation

2.1.1 Nameplate

Compare the nameplate on the device with the following diagram:

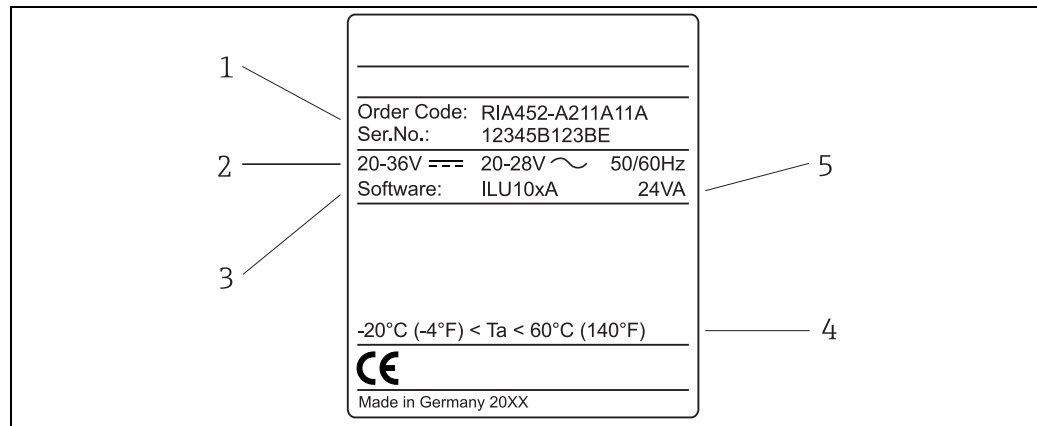

G09-RIA452xx-18-00-xx-xx-000

Fig. 2: Nameplate of the panel meter (example)

- 1 Order code and serial number of the device/Tab/
- 2 Power supply
- 3 Software version number
- 4 Ambient temperature
- 5 Performance

2.2 Scope of delivery

The scope of delivery of the panel meter comprises:

- Panel meter for panel mounting
- Multilanguage Brief Operating Instructions as hard copy
- Operating Instructions on CD-ROM
- CD-ROM with PC configuration software and interface cable RS232 (optional)
- Fixing clips
- Sealing ring



Please note the device accessories in Section 8 'Accessories' in the Operating Instructions.

2.3 Certificates and approvals

CE mark, declaration of conformity

The panel meter is designed to meet state-of-the-art safety requirements, has been tested and left the factory in a condition in which it is safe to operate. The device meets the relevant standards and directives as per IEC 61 010-1 "Safety requirements for electrical equipment for measurement, control and laboratory use".

The device described in these Operating Instructions thus meets the legal requirements of the EU directives. The manufacturer confirms that the device has been tested successfully by affixing the CE mark.

3 Installation

3.1 Installation

The permitted ambient conditions (see Section 10 "Technical data" in the Operating Instructions) must be observed when installing and operating. The device must be protected against the effects of heat.

3.1.1 Dimensions

Please note the installation depth of 150 mm (5.91 in) for the measuring device plus cable. Additional dimensions are provided in →  3 and Section 10 "Technical data" in the Operating Instructions.

3.1.2 Mounting location

Installation in panel with cutout 92x92 mm (3.62x3.62 in) (as per EN 60529). The mounting location must be free from vibrations.

3.1.3 Orientation

Horizontal +/- 45° in every direction.

3.2 Installation instructions

The required panel cutout is 92x92 mm (3.62x3.62 in). Please note the installation depth of 150 mm (5.91 in) for the measuring device plus cable.

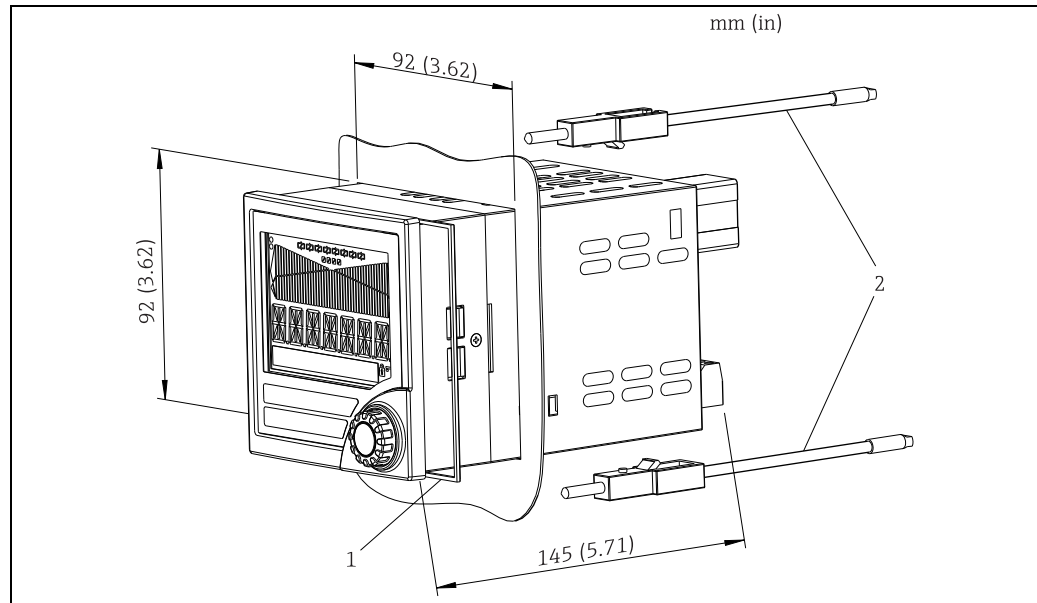

Fig. 3: Installation in panel

1. Push the device with the sealing ring (item 1) through the panel cutout from the front.
2. Keep the device horizontal and suspend the two fixing clips (item 2) in the recesses provided.
3. Tighten the screws of the fixing clips evenly with a screwdriver.
4. Remove the protective strip from the display.

The dimensions of the panel meter are provided in the "Technical data" section of the Operating Instructions.

4 Wiring

4.1 Quick wiring guide

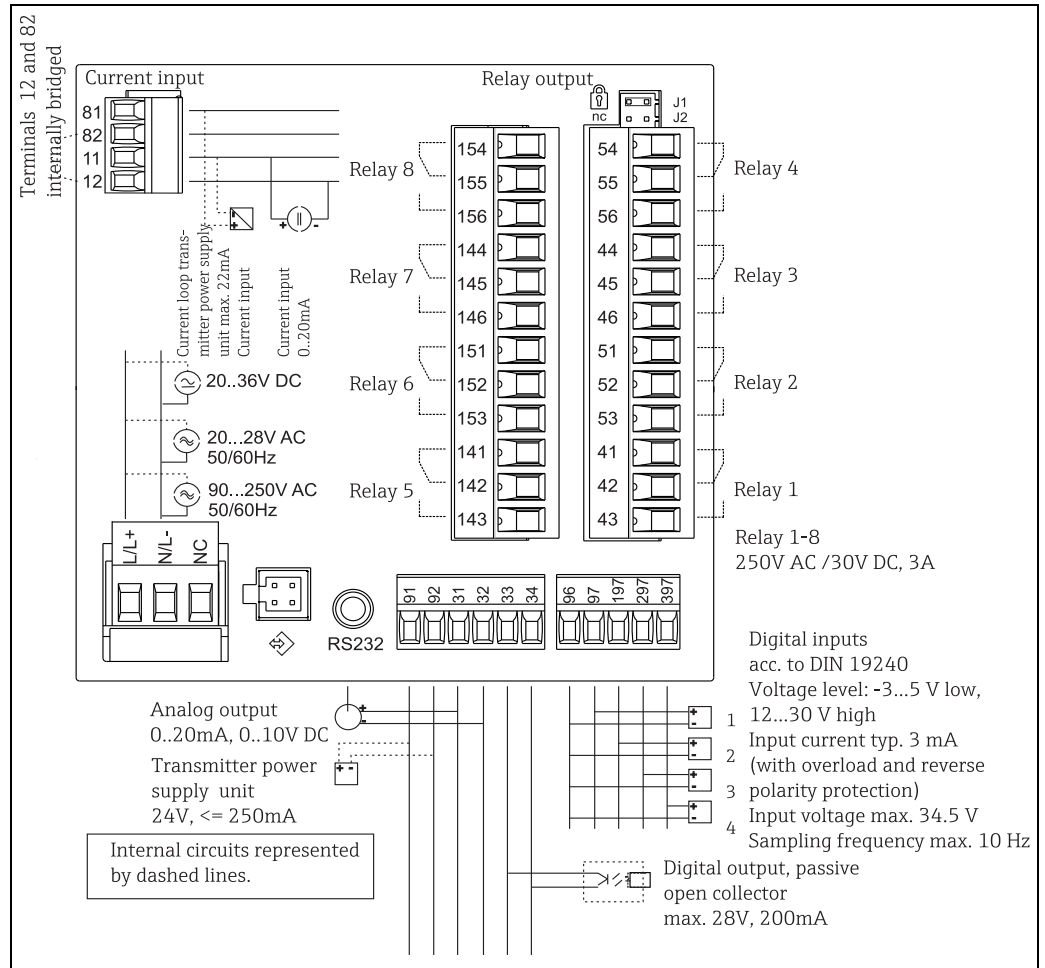

Fig. 4: Terminal assignment of the panel meter (universal input → Page 11)

Terminal assignment

Terminal	Terminal assignment	Type
L/L+	L for AC L+ for DC	Power supply
N/L-	N for AC L- for DC	
NC	Not connected	
J1	Jumper for locking device operation via hardware. If the jumper is set to J1, the configuration cannot be modified.	The device can always be configured with the PC software via RS232 even if the jumper is set to J1.
J2	Not connected	
11	+ 0/4 to 20 mA signal	Current input
12	Signal ground (current)	

Terminal	Terminal assignment	Type
81	24 V sensor power supply 1	Transmitter power supply (optionally intrinsically safe)
82	Ground, sensor power supply 1	
41	Normally closed (NC)	Relay 1
42	Common (COM)	
43	Normally open (NO)	
51	Normally closed (NC)	Relay 2
52	Common (COM)	
53	Normally open (NO)	
44	Normally closed (NC)	Relay 3
45	Common (COM)	
46	Normally open (NO)	
54	Normally closed (NC)	Relay 4
55	Common (COM)	
56	Normally open (NO)	
141	Normally closed (NC)	Relay 5 (optional)
142	Common (COM)	
143	Normally open (NO)	
151	Normally closed (NC)	Relay 6 (optional)
152	Common (COM)	
153	Normally open (NO)	
144	Normally closed (NC)	Relay 7 (optional)
145	Common (COM)	
146	Normally open (NO)	
154	Normally closed (NC)	Relay 8 (optional)
155	Common (COM)	
156	Normally open (NO)	
96	Ground for digital status inputs	Digital inputs
97	+ digital status input 1	
197	+ digital status input 2	
297	+ digital status input 3	
397	+ digital status input 4	

Terminal	Terminal assignment	Type
31	+ analog output	Analog output (optional)
32	Ground, analog output	
33	+ digital output	Digital output (optional)
34	Ground, digital output	
91	24 V sensor power supply 2	Transmitter power supply
92	Ground, sensor power supply 2	

Universal input option

The device can be optionally equipped with a universal input instead of a current input.

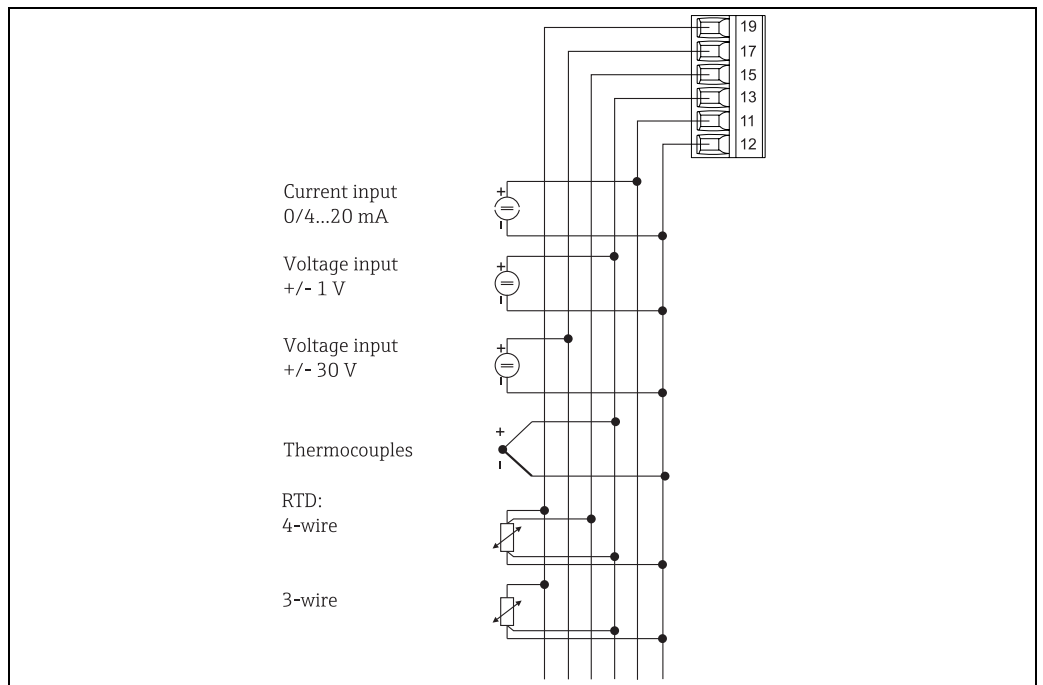

Fig. 5: Universal input terminal assignment

G09-RIA452xx-04-10-xx-en-002

Terminal assignment

Terminal	Terminal assignment
11	+ 0/4 to 20 mA signal
12	Signal ground (current, voltage, temperature)
13	+ 1 V, + thermocouples, - resistance thermometer signal (3/4 wire)
15	+ resistance thermometer signal (4-wire)
17	+ 30 V
19	+ resistance thermometer power supply (3-wire/4-wire)

4.2 Connecting the device

⚠ CAUTION

Danger through electric tension

- ▶ Do not install or wire the device when it is connected to the power supply.

4.2.1 Connecting the power supply

NOTICE

Damage to device through wrong supply voltage

- ▶ Before wiring the device, ensure that the supply voltage corresponds to the specification on the nameplate.
- ▶ For the 90 to 250 V AC version (power supply connection), a switch marked as a separator, as well as an overvoltage organ (rated current ≤ 10 A), must be fitted in the supply line near the device (easy to reach).

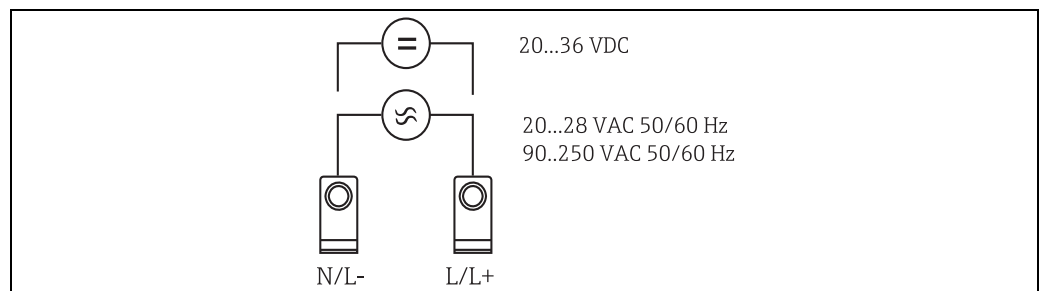

Fig. 6: Connecting the power supply

4.2.2 Connecting external sensors



Active and passive sensors with analog, TC, resistance and RTD sensors can be attached to the device.

Depending on the type of signal of the sensor in question, the terminals can be freely selected.

Current input 0/4 to 20 mA

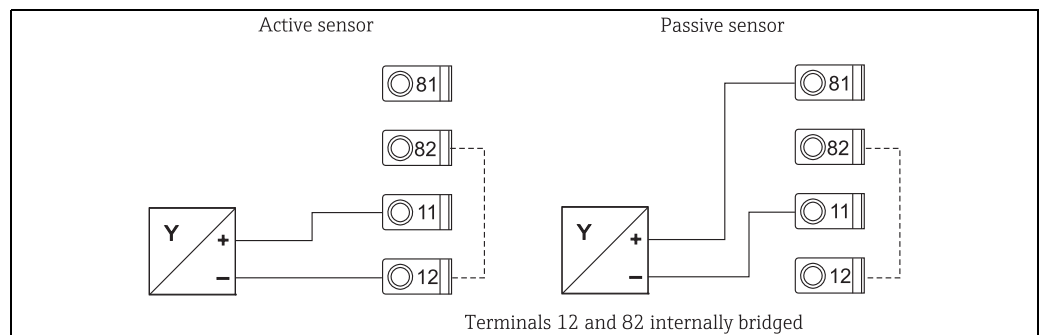

Fig. 7: Connection of the two-wire sensor to the current input 0/4 to 20 mA

Universal input

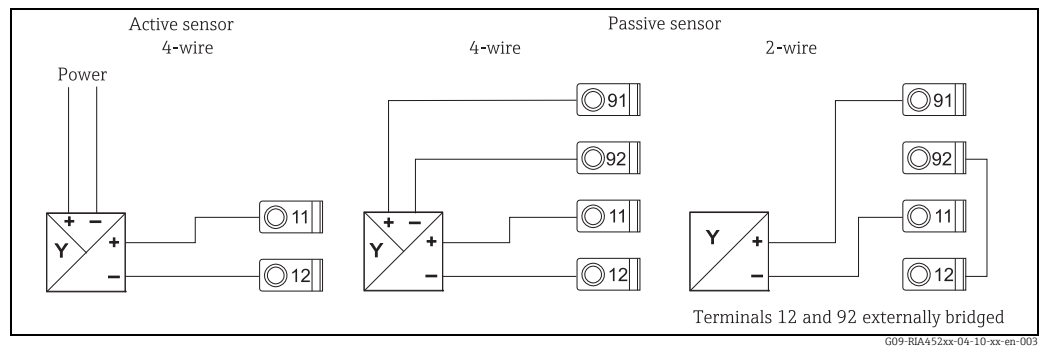

Fig. 8: Connection of the four-wire sensor, transmitter power supply and universal input

4.3 Post-connection check

Device condition and specifications	Notes
Is the device or cable damaged (visual inspection)?	-
Electrical connection	Notes
Does the supply voltage match the specifications on the nameplate?	90 to 250 V AC (50/60 Hz) 20 to 36 V DC 20 to 28 V AC (50/60 Hz)
Are all of the terminals firmly engaged in their correct slots? Is the coding on the individual terminals correct?	-
Are the mounted cables strain relieved?	-
Are the power supply and signal cables correctly connected?	See wiring diagram on the housing
Are all screw terminals firmly tightened?	-

5 Operation

5.1 Quick operation guide

M1	<i>Analog input</i> INPUT	<i>Signal type</i>	<i>Connection type*</i>	<i>Curve</i>	<i>Signal damping</i>
		Signal type	Connection	Curve	Damp
		<i>Dimension</i>	<i>Decimal point</i>	<i>0% value</i>	<i>100% value</i>
		Dimension	Dec. point	0% value	100% value
		<i>Offset</i>	<i>Comparat. temperature*</i>	<i>Fixed comparat. temp.*</i>	<i>Open circuit detection</i>
		Offset	Comp. temp.	Const. temp.	Open circ.
M2	<i>Display</i> DISPLAY.	<i>Assign numerical display</i>	<i>Alternating display</i>	<i>Assign bargraph</i>	<i>Decimal point bargraph</i>
		Ref. num.	Displ. sw.	Ref. bargraf	Dec. point
		<i>Bargraph 0% value</i>	<i>Bargraph 100% value</i>	<i>Assign bargraph</i>	
		Bar 0%	Bar 100%	Ref. bargraf	
M3	<i>Analog output*</i> ANALOG OUT	<i>Assignment</i>	<i>Damping</i>	<i>Output range</i>	<i>Decimal point</i>
		Ref. num.	Out damp	Out range	Dec. point
		<i>0% value</i>	<i>100% value</i>	<i>Offset</i>	<i>Output in the event of a fault</i>
		Out 0%	Out 100%	Offset	Fail mode
		<i>Value in the event of a fault</i>	<i>Simulation mA</i>	<i>Simulation Volt</i>	
		Fail value	Simu mA	Simu V	
M5	<i>Digital input 1-4</i> DIGITAL INP.	<i>Function digital input 1-4</i>	<i>Active level 1-4</i>	<i>Pump monitoring sampling time</i>	
		Function	Level	Sampl. time	

*) Only available if the option in question is installed in the device

M10- M17	<i>Limit 1-4 (8)*</i> LIMIT	<i>Assignment</i>	<i>Function 1-4 (8)</i>	<i>Decimal point</i>	<i>Switch point A</i>	<i>Switch point B</i>
		Ref. num	Function	Dec. point	Setpoint A	Setpoint B
		<i>Hysteresis or switch-back gradient</i>	<i>Switching delay 1-4 (8) in seconds</i>	<i>Alternate function 1-4</i>	<i>Delay for 1st switch-on every 24 h</i>	<i>Switch-on period for switch-on every 24 h</i>
		Hysteresis	Delay	Alternate	Sw. delay	Sw. period
M18	<i>Integration*</i> Integration	<i>Signal source for integration</i>	<i>Pre-counter</i>	<i>Integration base</i>	<i>Decimal point factor</i>	<i>Conversion factor</i>
		Ref. Integr.	Pre-counter	Integr. base	Dec. factor	Factor
		<i>Dimension totalizer</i>	<i>Decimal point totalizer</i>	<i>Set pre-counter</i>	<i>Set preliminary alarm</i>	<i>Display totalizer</i>
		Dimension	Dec. point T	Set count A	Set count B	Totalizer
		<i>Reset totalizer</i>	<i>Flow calculation</i>	<i>Dimension of input signal</i>	<i>Dimension of linearized value</i>	<i>Decimal point for formula</i>
		Reset total	Calc flow	Dim. Input	Dim. flow	Dec. flow
		<i>Decimal point for display</i>	<i>Alpha value</i>	<i>Beta value</i>	<i>Gamma value</i>	<i>C value</i>
Dec. point	Alpha	Beta	Gamma	C		
		<i>Khafagi- Venturi channels</i>	<i>Iso-Venturi channels</i>	<i>Venturi channels as per British Standard</i>	<i>Parshall channels</i>	<i>Parshall-Bowlus channels</i>
		Kha Venturi	Iso-Venturi	BST-Venturi	Parshall	Parshall-Bow
		<i>Rectangular weirs</i>	<i>Rectangular weirs with constriction</i>	<i>Rectangular weirs as per NFX</i>	<i>Rectangular weirs as per NFX with constriction</i>	<i>Trapezoid. weirs</i>
		Rect. WTO	Rect. WThr	NFX Rect. WTO	NFX Rect. WThr	Trap. WTO
		<i>Triangular weirs</i>	<i>Triangular weirs as per British Standard</i>	<i>Triangular weirs as per NFX</i>	<i>Width</i>	
		V. weir	BST V. weir	NFX V. weir	width	
M19	<i>Pulse output*</i> PULSE OUT	<i>Decimal point pulse value</i>	<i>Pulse value</i>	<i>Pulse width</i>	<i>Simulation pulse output</i>	
		Dec value	Unit Value	Pulse width	Sim pulseout	

*) Only available if the option in question is installed in the device

M20	<i>Min/Max memory</i> MIN/MAX	<i>Signal source for Min/Max</i>	<i>Decimal point</i>	<i>Display minimum value</i>		
		Ref. min/max	Dec. point	Min. value		
		<i>Display maximum value</i>	<i>Reset minimum value</i>	<i>Reset maximum value</i>		
		Max. value	Reset min	Reset max		
M21	<i>Linearizationtable</i> LIN-TABLE	<i>Number of support points</i>	<i>Dimension of linearized value</i>	<i>Decimal point Y-axis</i>	<i>Delete all support points</i>	<i>Display all support points</i>
		Counts	Dimension	Dec. Y value	Del points	Show points
M23- Mxx	<i>Lin. support points</i> NO 01 NO 32	<i>X-axis</i>	<i>Y-axis</i>			
		X value	Y value			
M55	<i>Operating parameters</i> PARAMETERS	<i>User code</i>	<i>Limit value lock</i>	<i>Program name</i>	<i>Program version</i>	<i>Pump alternation function</i>
		User code	Limit lock	Prog. name	Version	Func. alt.
		<i>Relay lock time</i>	<i>Relay failsafe mode</i>	<i>Time for gradient evaluation</i>	<i>Failsafe mode 4-20 mA input</i>	<i>Error limit 1</i>
		Lock time	Rel. Mode	Grad. Time	Namur	Range 1
		<i>Error limit 2</i>	<i>Error limit 3</i>	<i>Error limit 4</i>	<i>Display contrast</i>	
		Range 2	Range 3	Range 4	Contrast	
M56	SERVICE	Only for service staff. The service code must be entered.				
M57	EXIT	Exit the menu. If you have changed parameters, you are asked whether you want to save the changes.				
M58	SAVE	Changes are saved and you exit the menu.				

*) Only available if the option in question is installed in the device

5.2 Display and operating elements



Remove the protective strip from the display as this restricts display legibility otherwise.

5.2.1 Display

Range	Display	Relay	Analog output	Integration
Input current is below the lower error limit	Display "nnnnn"	Fault condition	Set failsafe mode	No integration
Input current above lower error limit and below lower limitations of validity	Display "-----"	Normal limit value behavior	Normal behavior with max. 10% overrange. No output < 0 mA/0 V possible	Normal behavior (negative integration not possible)
Input current in valid range	Display scaled measured value	Normal limit value behavior	Normal behavior with max. 10% overrange. No output < 0 mA/0 V possible	Normal behavior (negative integration not possible)
Input current below upper error limit and above upper limitations of validity	Display "-----"	Normal limit value behavior	Normal behavior with max. 10% overrange. No output < 0 mA possible.	Normal behavior (negative integration not possible)
Input current above upper error limit	Display "uuuuu"	Fault condition	Set failsafe mode	No integration

Relay display

No power to relay: no display

Power to relay:  (symbol lit)

Digital input status display

Digital input configured:  (green)

Signal at digital input:  (yellow)



Information on troubleshooting can be found in Sections 9.1 and 9.2 of the Operating Instructions.

5.3 Local operation

Operating menu activated by pressing the jog/shuttle dial for 3 seconds at least.

5.3.1 Operation via the jog/shuttle dial

A) 3-key function

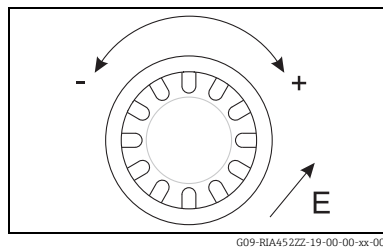

- Press = "Enter"
- Rotate in clockwise direction = "+"
- Rotate in counterclockwise direction = "-"

Fig. 9: Operation via jog/shuttle dial

B) Selection from list

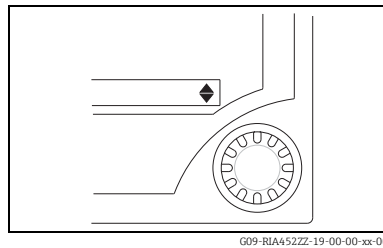

- ▼ Arrow pointing down:
Option is at the top of the picklist. The other entries become visible when the jog/shuttle is turned in the clockwise direction.
- ▲ Both arrows visible:
User is in the middle of the picklist.
- ▲ Arrow pointing up:
The end of the picklist is reached. The user moves back towards the start when the jog/shuttle is turned in the counterclockwise direction.

Fig. 10: Selecting from list via jog/shuttle dial

5.3.2 Entering text

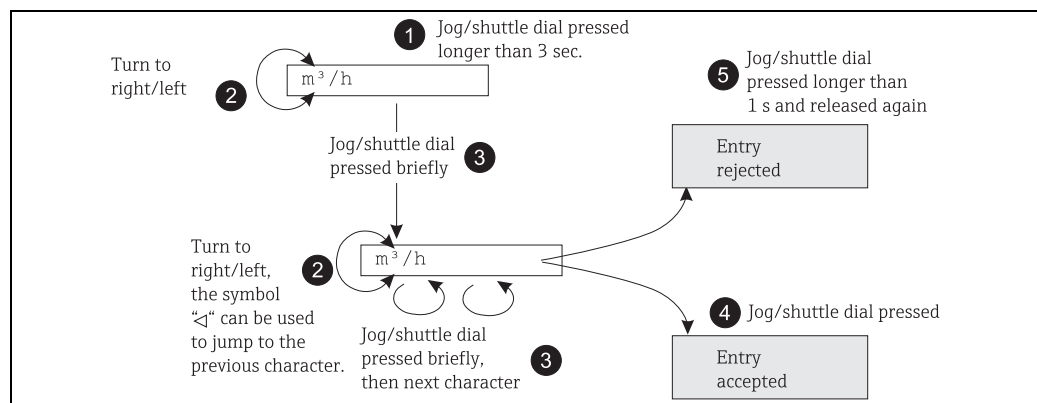

Fig. 11: Text entry

Item No.	Description
1	Activate the operating menu by pressing the jog/shuttle dial for at least 3 seconds. The first character then starts flashing.
2	You can change the flashing (selected) character by turning the jog/shuttle dial (see "Possible characters" in the next paragraph). You can go back to the previous character by selecting the back symbol (arrow to left).
3	Press the jog/shuttle dial to accept the selected character and to switch to the next character.
4	Press the jog/shuttle dial briefly for the last character to accept the entry.
5	Press the jog/shuttle dial for longer than 1 second (max. 2 seconds) to reject the entry at the point in question.

Possible characters

The following characters can be entered:

Space +ABCDEFGHIJKLMNOPQRSTUVWXYZabcdefghijklmnopqrstuvwxyz0123456789/
 \%²³+-.:;* () followed by return symbol (arrow to left)

5.3.3 Disabling the programming mode

User code

The configuration can be protected against unintentional access by means of a four-digit code. This code is defined in menu item 55 "Parameter/user code". All the parameters remain visible but can only be changed after entering the user code. The "key" symbol is shown on the display. If the limit values are also to be locked, the "Limit code" must be set to "On" in menu item 55. Limit values can then only be changed after entering the user code. If the limit code is set to "Off", limit values can be changed without entering the user code. All the other parameters are locked, however.

Hardware locking

In addition, configuration can also be locked using a connector on the rear of the device (see drawing). This is indicated by the "padlock" symbol on the display. To hardware-lock the measuring device, insert the jumper into position J1 in the top right-hand corner on the rear of the device.

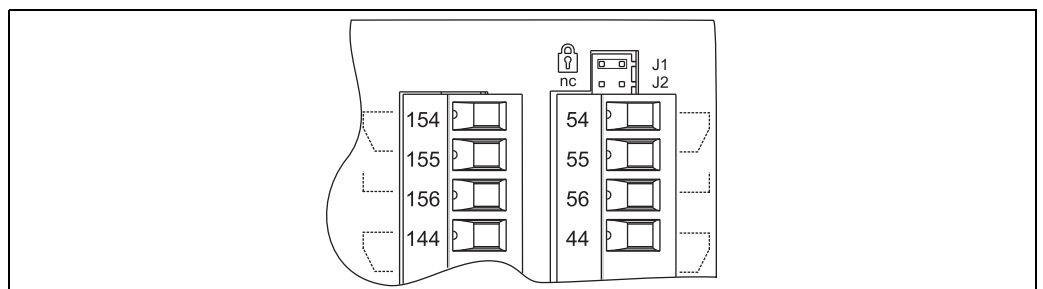

Fig. 12: Position of the jumper on the rear of the device

G09-RIA452ZZ-19-00-00-xx-004



The hardware lock does not affect the PC operating software.

6 Commissioning

6.1 Function check

Make sure that all post-connection checks have been carried out before you commission your device:

- Checklist Section 4.3 'Post-connection check'



Remove the protective strip from the display as this restricts display legibility otherwise.

6.2 Switching on the measuring device

Once the operating voltage is applied, the green LED indicates that the instrument is operational.

- When the unit is delivered, the device parameters are used as per the factory settings.
- When commissioning a device already configured or preset, measuring is immediately started as per the settings. The limit values only switch once the first measured value has been determined.
- The limit values are only activated as per their configuration once a valid measured value is present.

6.3 Device configuration

This section describes all the configurable instrument parameters with the associated value ranges and factory settings (default values, marked in bold).

6.3.1 Analog input - INPUT/M1

All the parameters that can be selected for the input can be found under the analog input menu item which is marked as INPUT in the device.

Function (menu item)	Parameter setting	Description
Signal type	4 - 20 mA 0 - 20 mA 0 - 5 mA (*) 0 - 100 mV (*) 0 - 200 mV (*) 0 - 1 V (*) 0 - 10 V (*) ± 150 mV (*) ± 1 V (*) ± 10 V (*) ± 30 V (*) Type B (IEC584) (*) Type J (IEC584) (*) Type K (IEC584) (*) Type L (DIN43710) (*) Type L (GOST) (*) Type N (IEC584) (*) Type R (IEC584) (*) Type S (IEC584) (*) Type T (IEC584) (*) Type U (DIN43710) (*) Type D (ASTME998) (*) Type C (ASTME998) (*)	Selects the signal type of the connected sensor. Parameters marked with an asterisk (*) can only be selected with the universal input option.

Function (menu item)	Parameter setting	Description
Signal type	PT50 (GOST) (*) PT100 (IEC751) (*) PT100 (JIS1604) (*) PT100 (GOST) (*) PT500 (IEC751) (*) PT500 (JIS1604) (*) PT500 (GOST) (*) PT1000 (IEC751) (*) PT1000 (JIS1604) (*) PT1000 (GOST) (*) Cu50 (GOST) (*) Cu100 (GOST) (*) 30 - 3000 Ohm (*)	Selects the signal type of the connected sensor. Parameters marked with an asterisk (*) can only be selected with the universal input option.
Connection	3 Wire 4 Wire	Configures the sensor connection in 3-wire or 4-wire technology. Can only be selected for "Signal type" 30-3000 Ω, PT50/100/1000, Cu50/100
Curve	Linear Quad. °C °F Kelvin	Linear or quadratic (quad.) characteristic of the sensor used. Can be selected for analog signals. °C, °F, Kelvin physical measured variable, can be selected for temperature sensors.
Damp	0..99.9 0	Signal damping of measuring input with 1st order low pass. Time constant can be selected from 0 to 99.9 sec.
Dimension	XXXXXXXXX %	The technical unit or an arbitrary text for the measured value of the sensor can be configured here. Max. length 9 characters.
Dec. point	XXXXX XXXX.X XXX.XX XX.XXX X.XXXX	Number of places after the decimal point for displaying the measured value.
0% value	-99999..99999 0	Start value of measured value, can be selected for analog signal types
100% value	-99999..99999 100.0	End value of measured value, can be selected for analog signal types
Offset	-99999..99999 0.0	Shifts the zero point of the response curve. This function is used to adjust the sensor.
Comp. temp	Intern const	Comparative temperature for thermocouple measurement. An internal cold junction (= Intern) or a constant value (= const) can be selected.
Const. temp	9999.9 20.0	Fixed comparative temperature. This can only be selected if const is set for "Cmp. Temp".
Open circ.	No Yes	Switch cable open circuit detection off or on for thermocouples

Adjusting the analog input

The input can be adjusted to the sensor with the aid of the following parameters. For current, voltage and resistance sensors, a scaled value is calculated from the sensor signal.

For temperature outputs, the scaled value is calculated from linearization tables. The temperature value can be converted to degrees Celsius, degrees Fahrenheit or Kelvin. In addition, the temperature value can be corrected by means of an offset.



The signal types 4 to 20 mA, thermocouples and resistance thermometers are monitored for cable open circuit. Long reaction times can occur in the case of resistance thermometers.

6.3.2 Display - DISPLAY/M2

All of the display settings are grouped under this menu item.

Function (menu item)	Parameter setting	Description
Ref. num.	Input Lin. table Total (*) Inp.+Lint. Inp.+Tot. (*) Lint.+Tot. (*) In+Lin+Tot (*) Batch (*)	For choosing the display value on the display. (If a combination is selected, e.g. "Inp.+Lint", the display alternates between the selected display values, e.g. measured value (Inp.) and linearized measured value (Lint.)) <ul style="list-style-type: none"> ▪ Input = measured value ▪ Lin. table = linearized measured value or current flow rate for calculation of channel ▪ Total = integrated value ▪ Inp.+Lint. = alternates between measured value and linearized measured value ▪ Inp.+Tot. = alternates between measured value and integrated value ▪ Lint.+Tot. = alternates between linearized measured value and integrated value ▪ In+Lin+Tot = measured value, linearized measured value or integrated value ▪ Batch = preset counter Settings marked with an asterisk (*) are only available if the pulse output or integration option is available and has been configured
Display sw.	0 to 99 sec 0	Selectable period for displaying the individual values if combinations of display values have been selected under Ref. num. . This setting is only available if the pulse output or integration option is available and has been configured
Ref. bargraf	Input Lintab	Selects the signal source for the bar graph
Dec. point	XXXXX XXXX.X XXX.XX XX.XXX X.XXXX	Number of digits after the decimal point for bar graph scaling.
Bar 0%	-99999..99999 0.0	Start value for the bar graph
Bar 100%	-99999..99999 100.0	End value for the bar graph

Function (menu item)	Parameter setting	Description
Bar rise	Right Left	Bar graph orientation. <ul style="list-style-type: none"> Right = 100% value (rising from left to right) Left = 100% value left (falling from left to right)

6.3.3 Analog output - ANALOG OUT/M3



This item is only available if the "Analog output" option is available in your device.

Function (menu item)	Parameter setting	Description
Ref. num.	Input Lintab	Selects which value is output at the analog output. <ul style="list-style-type: none"> Input = measured value Lintab = linearized measured value or current flow rate for calculation of channel
Out damp	0..99.9 0.0	Signal damping of measuring input with 1st order low pass. Time constant can be selected from 0 to 99.9 sec.
Out range	Off 0 - 20 mA 4 - 20 mA 0 - 10 V 2 - 10 V 0 - 1 V	Signal type of output "Off" switches the output signal off completely.
Dec. point	XXXXX XXXX.X XXX.XX XX.XXX X.XXXX	Number of places after the decimal point for outputting the measured value. Can be selected for analog signal types
Out 0%	-99999..99999 0.0	Start value of the output signal
Out 100%	-99999..99999 100.0	End value of the output signal
Offset	-999.99..999.99 0.00	Shifts the zero point of the output curve in mA or V.
Fail mode	Hold const Min Max	Output value if a sensor or device error occurs. <ul style="list-style-type: none"> Hold = last valid value Const = freely selectable value Min = output value 3.5 mA for 4 to 20 mA, otherwise 0 V or 0 mA Max = output value 22.0 mA for 0/4 to 20 mA, otherwise 1.1 V or 11 V
Fail value	0..999.99 0.00	The freely selectable value for "Fail mode = Const" can be set here. Current output: 0 to 22 mA Voltage output: 0 to 11 V

Function (menu item)	Parameter setting	Description
Simu mA	OFF 0.0 mA 3.6 mA 4 mA 10 mA 12 mA 20 mA 21 mA	Simulates the current output and outputs the selected current at the output, regardless of the input value. Is automatically set to OFF when the Simu mA menu item is exited. The parameter is only available if the mA parameter is configured in Out range.
Simu V	OFF 0.0 V 5.0 V 10.0 V	Simulates the voltage output and outputs the selected voltage at the output, regardless of the input value. Is automatically set to OFF when the Simu V menu item is exited. The parameter is only available if the V parameter is configured in Out range.

6.3.4 Digital input - DIGITAL INP./M5

The settings for the digital status inputs, e.g. for monitoring pumps, starting/stopping the counter or resetting the min/max-value memory are grouped in this section.



- The digital inputs 1 to 4 are permanently assigned to relays 1 to 4 in the PUMP function. Relay 1 is monitored by digital input 1, relay 2 by digital input 2 etc.
- When the "Batch" function is used, digital input 1 is permanently assigned to a preset value count function. Configuration for this digital input is then not possible.

Function (menu item)	Parameter setting	Description
Function	Off Pump Res Tot. (*) Start/Stop (*) Res MinMax	Function of the selected digital input. <ul style="list-style-type: none"> ■ Off ■ Pump = pump monitoring (see Pump monitoring function) ■ Res Tot. = reset the totalizer* ■ Start/Stop = start or stop the totalizer* ■ Res MinMax = reset the min/max memory values Parameters marked with an asterisk (*) are only available for the pulse output option if this function has been configured.
Level	Low High	Selects the side for evaluation. <ul style="list-style-type: none"> ■ Low = descending side ■ High = increasing side
Sampl. time	0..99 0	Defines the time (in seconds) within which pump feedback at the digital input is to be expected. If there is no feedback within the defined time, an error message is generated and a second pump is activated if more than one pump is available. The setting for Sampl. time determines the type of monitoring of the digital input. Sampl. time = 0 means fault monitoring Sampl. time <> 0 means startup monitoring

Pump monitoring function

The digital inputs 1 to 4 are permanently assigned to relays 1 to 4 for the pump monitoring function. This function is activated for the relevant digital input using the **Function** parameter. **Pump** must be selected here.

Generally, two different types of monitoring are possible.

The setting for **Sampl. time** determines the operating mode chosen.

- **Fault monitoring:** Sampl. time = 0
In the case of fault monitoring, the level at the digital input is changed by a fault on the pump.
- **Startup monitoring:** Sampl. time <> 0
In the case of startup monitoring, feedback on the correct startup of the pump is sent to the panel meter via a level change at the digital input.

a) Fault monitoring operating mode

The status signal indicates availability of the pump in the fault monitoring operating mode. If a fault occurs, the status signal changes accordingly.

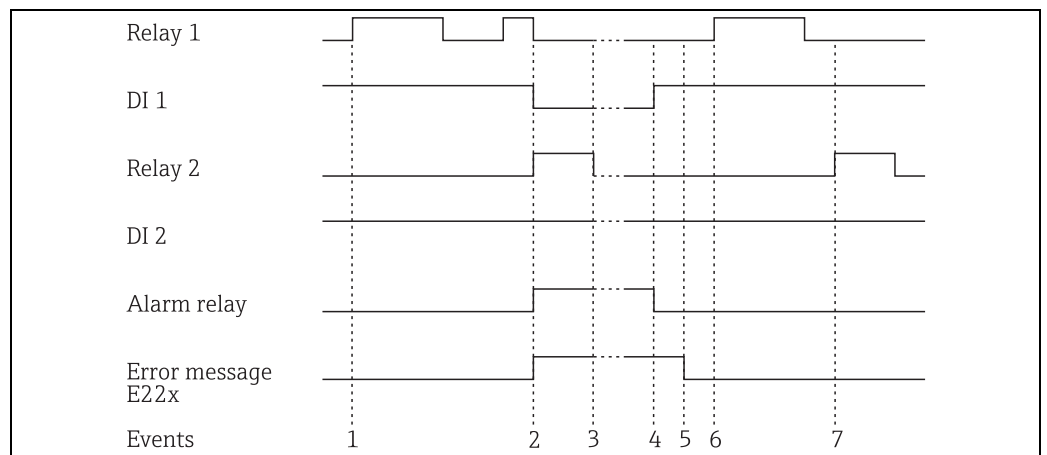

Fig. 13: Fault monitoring operating mode

G09-RIA45ZZ-16-10-xx-en-006

In event 1, pump 1 is requested due to limit value violation of the level. Pump 1 remains active until the level drops as much as required.

In event 2, a fault occurs at pump 1 during operation, status signal at DI1 changes. Pump 2 and the alarm relay are activated subsequently (if configured accordingly) and the pump fault is shown as a message on the display.

In event 3, the level has fallen so much that pumping is no longer necessary and pump 2 stops operation.

The fault at pump 1 was rectified, the status signal at DI1 changes once more. The alarm relay is reset, see event 4.

In event 5, the alarm relay and error message are acknowledged on the display by pressing the jog/shuttle.

Events 6 and 7 show uninterrupted operation of the system.

b) Startup monitoring

In the case of the startup monitoring operating mode, a change of the status signal is expected at the relevant digital input after a pump is activated. A waiting time is defined for this (Sampl. time, T). Alternating pump control is activated. If the signal does not change within the defined time, the pump is taken to be faulty.

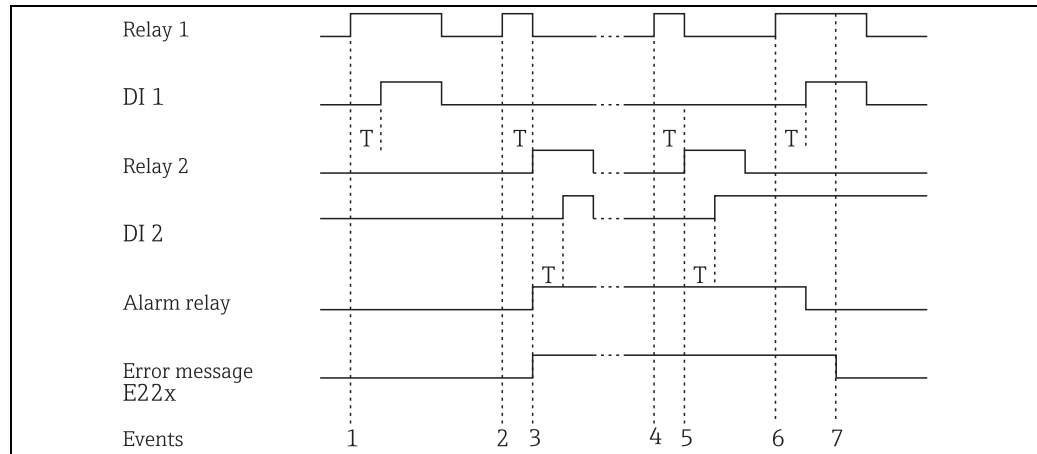

G09-RIA452ZZ-16-10-xx-en-007

Event 1 shows uninterrupted operation of pump 1. Pump 1 is activated upon request due to a limit value violation. The status signal at DI1, which changes within T, indicates that the pump is operating correctly, pump 1 continues pumping.

In event 2, there is no feedback at DI1 after pump 1 is activated and thus this pump is taken to be faulty. The alarm relay is activated and an error message is output on the display.

Pump 2 takes over pumping, event 3. This pump provides feedback at DI2 within the defined waiting time. Pumping continues until the limit value violation is undershot.

A new limit value violation occurs in event 4. A new attempt is made to start pump 1 due to alternating pump control. Pump 2 takes over as, once more, there is no feedback after the waiting time elapses (event 5). If the alarm relay and error message were not already active on the display, they are now.

In event 6, the level is exceeded once more and a pump is requested. Following alternating pump control, pump 1 is tried again. This time, feedback is from pump 1. The alarm relay is reset.

In event 7, the error message is acknowledged on the display. The status signal at the DI has no effect on the acknowledgement of the error message on the display.



A faulty pump is always restarted depending on the signal at the relevant digital input. Acknowledgement of the error message on the display has no effect on the pump resuming operation.

If a pump is faulty for more than 10 minutes, an attempt is made to restart it when the limit value is violated.

The following parameters must be configured:

Menu	Function (menu item)	Setting value
DIGITAL INP./M5	Function Level Sampl. time	Pump Low or High Sampling time in seconds
LIMIT 1 to 8	Alternate	Yes

6.3.5 Limit values - LIMIT 1 to 8/M10 to 17



If the "Batch" function is used, limit values 1 and 2 are permanently assigned activation in the event of a "preset counter" and "preliminary alarm" limit value. These limit values cannot be configured. They are not shown in the menu structure.

Function (menu item)	Parameter setting	Description
Ref. num.	Input Lin. table	Selects which value is used: <ul style="list-style-type: none"> Input: scaled value from analog input Lin. table = value from linearization table or current flow rate for calculation of channel
Function	Off Min Max Grad In band Out band Alarm Alarm inverse	Selects limit value and fault monitoring. In the event of device errors or incorrect input values (see error limits Range 1 to 4 → 40), the relays are switched in accordance with the failsafe mode configured in Rel. Mode (→ 40). <ul style="list-style-type: none"> Min: minimum with hysteresis (→ 28) Max: maximum with hysteresis (→ 28) Grad: gradient (→ 29) In band: validity range within two values Out band: validity range outside of two values Alarm: relay is used as an alarm relay Alarm inverse: relay is used as an alarm relay; the relay behaves in a safety-oriented manner with the result that it is de-energized if the power supply fails or if the display unit has a fault.
Dec. point	XXXXX XXXX.X XXX.XX XX.XXX X.XXXX	Number of digits after the decimal point for the limit value.
Setpoint A	-99999 to 99999 0.0	Measured value at which a change in the switch status occurs (slope for gradient). Default: 0.0
Setpoint B	-99999 to 99999 99999	The second setpoint can be configured for the "In band" and "Out band" operating modes and is only visible if one of these two functions was selected for this relay.
Hysteresis	-99999 to 99999 99999	For entering the hysteresis for the threshold at minimum/maximum as an absolute value.
Delay	0 to 99 0	Sets the limit value event delay once the threshold is reached (in seconds) (→ 30).
Alternate	No Yes	Determines the switching function for this relay: <ul style="list-style-type: none"> No: no alternating function; switch point permanently assigned to relay Yes: alternate function (→ 31) Relays 1-4 can be used for the alternate function.
Sw. delay	0..99 0	The starting time for 24-hour counting can be selected with Sw. delay. Every time the instrument is reset, the process of measuring 24 hours and the delay time is restarted. Example → 30
Sw. period	0..999 0	Limit value is activated cyclically every 24 hours for 0-999 seconds. The activation is delayed by [Sw.delay] hours by changing the hour value (example → 30).
Runtime		Displays the run time of the connected device, e.g. pump, in hours [h].
Count		Records the switching frequency of the limit value.

Function (menu item)	Parameter setting	Description
Reset	No Yes	Resets the run time and switching frequency for this limit value.
Simu relay	Off Low High	Simulation of the selected limit value. Is automatically set to Off when the menu item is exited.

Min operating mode

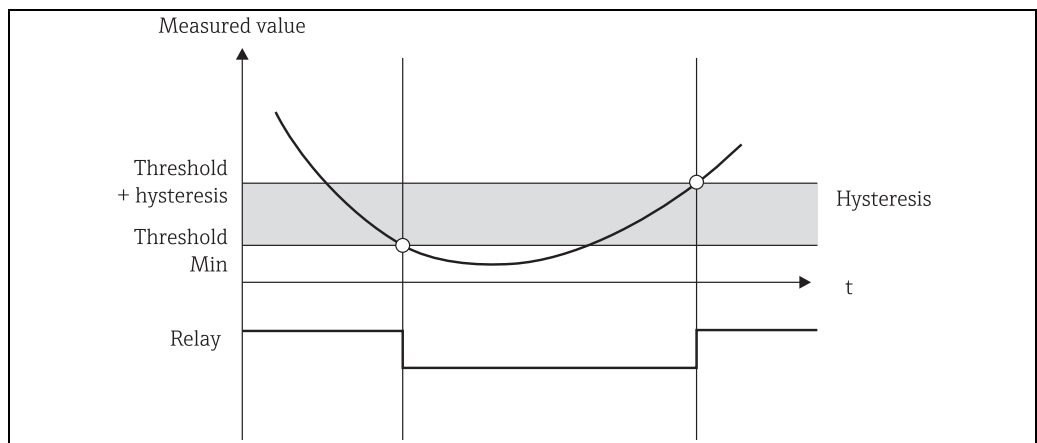

Fig. 14: Min operating mode

The following parameters must be configured:

Menu	Function (menu item)	Setting value
LIMIT 1 to 8/M10 to 17	Function Setpoint A Hysteresis	Min Value for threshold Value for hysteresis

Max operating mode

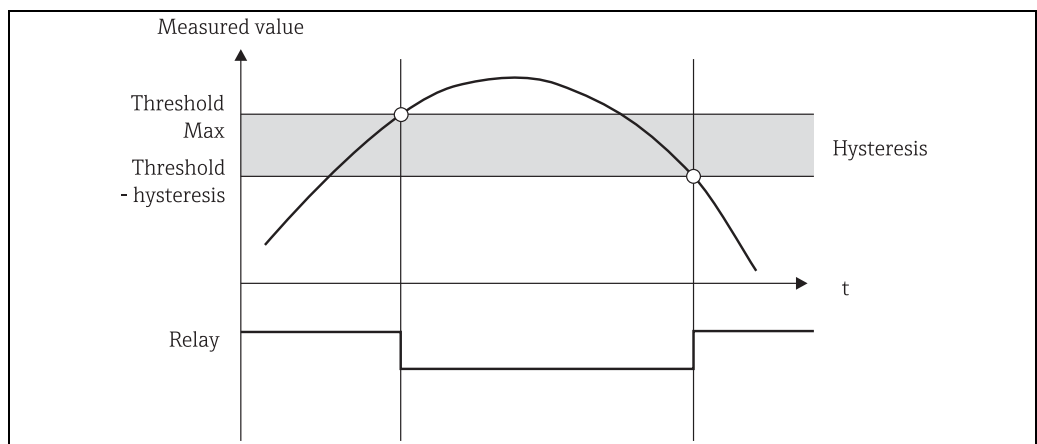

Fig. 15: Max operating mode

The following parameters must be configured:

Menu	Function (menu item)	Setting value
LIMIT 1 to 8/M10 to 17	Function Setpoint A Hysteresis	Max Value for threshold Value for hysteresis

Grad operating mode

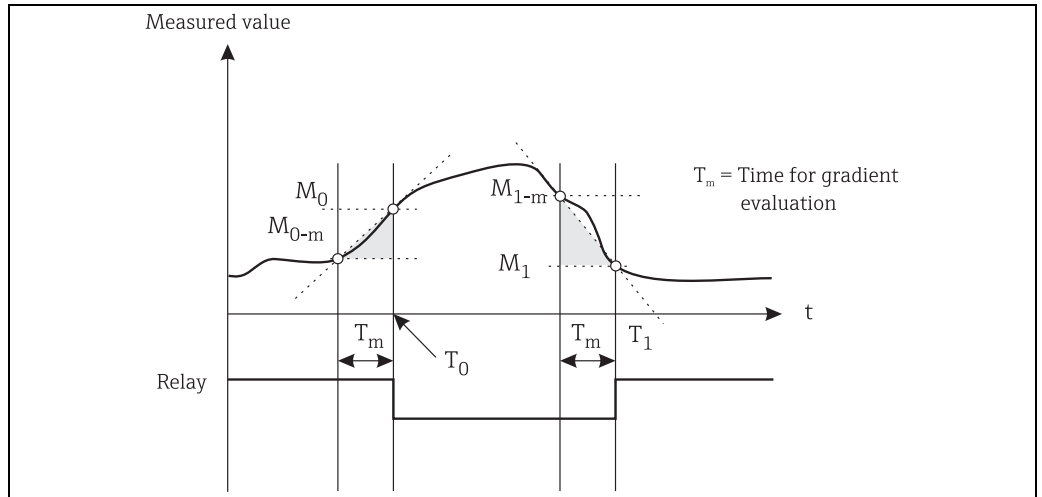

Fig. 16: Grad operating mode

The "Grad" operating mode is used for monitoring the changes in the input signal over time. The time basis T_m of the monitoring system is configured in the "PARAMETER/M55 -> Grad. time" menu.

The difference between the lower range value M_{0-m} and the upper range value M_0 of the interval is calculated. If the calculated value is greater than the value set under "Setpoint A", the relay is switched in accordance with the failsafe mode configured in "Rel. Mode" (→ 40).

The relay is switched on again once the difference between M_{1-m} and M_1 drops below the value set in "Hysteresis". The sign determines the direction of signal change. Positive values monitor an increase in the measured value while negative values monitor a decrease. A new value is calculated every second (floating interval).

The following parameters must be configured:

Menu	Function (menu item)	Setting value
LIMIT 1 to 8/M10 to 17	Function Setpoint A Hysteresis Grad. time	Grad Gradient value for threshold Value for hysteresis Interval time in seconds

Alarm operating mode

A relay with the "Alarm" operating mode is activated if the following events occur:

- Analog input (4-20 mA) < 3.6 mA (lower Namur limit) or > 21.0 mA (upper Namur limit)
- EEPROM HW error (E101)
The relay remains picked up even after acknowledging.
- Implausible calibration data (E103)
The relay remains picked up even after acknowledging.
- Bus error reading the min/max data after power-up (E104)
The relay remains picked up even after acknowledging.

- Bus error reading the relay data after power-up (E105)
The relay remains picked up even after acknowledging.
- Universal card HW error (E106)
The relay remains picked up even after acknowledging.
- Pulse buffer overflow (E210)
The relay is de-energized after acknowledgement.
- Pump error at the digital input x in question (E22x)
The relay remains picked up even after acknowledging.

Delay

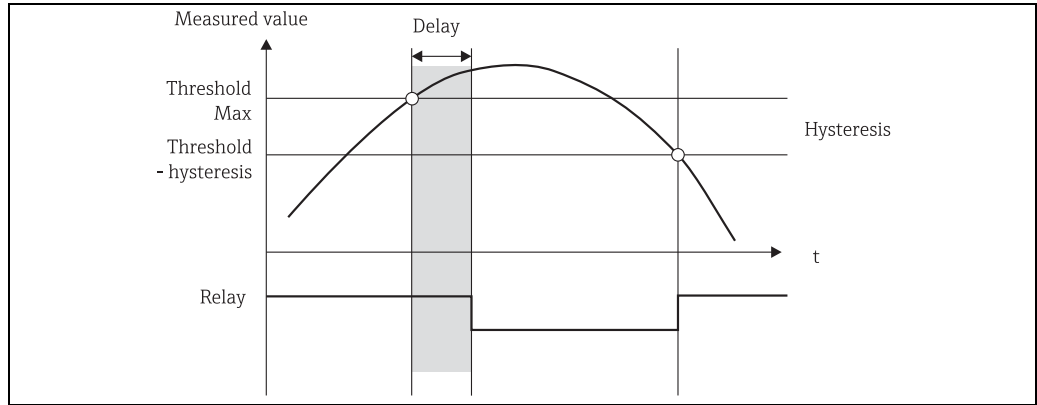

Fig. 17: Delay

The following parameters must be configured:

Menu	Function (menu item)	Setting value
LIMIT 1 to 8/M10 to 17	Setpoint A Hysteresis Delay	Value for threshold Value for hysteresis Delay time in [s]

24-hour activation function

Pumps with long downtimes can be activated cyclically with the 24-hour activation function for the time defined in **Sw. period** (0-999 seconds).

The starting time for the 24-hour step interval can be postponed by 0 to 23 hours with the **Sw. delay** setting.

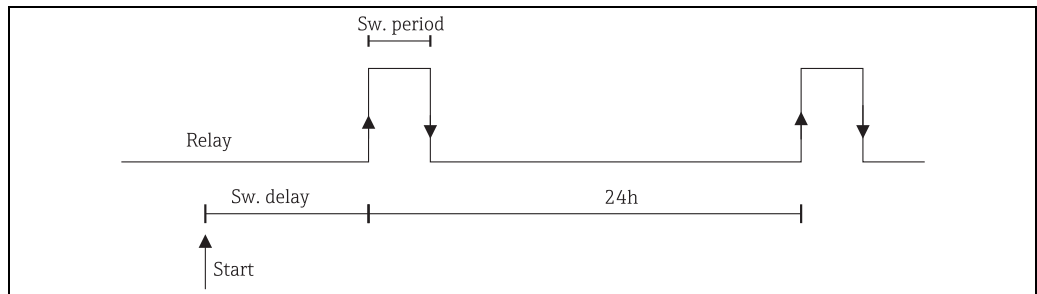

Fig. 18: 24-hour activation function

Example: time at the time of configuration 12 midday, desired start of 24-hour counting 22:00 (10 p.m.) ⇒ set Sw. delay to 10.



If power is switched off, the time for the 24-hour activation function starts again.

The following parameters must be configured for the example above:

Menu	Function (menu item)	Setting value
LIMIT	Sw. period Sw. delay	Activation duration Activation delay

Alternate

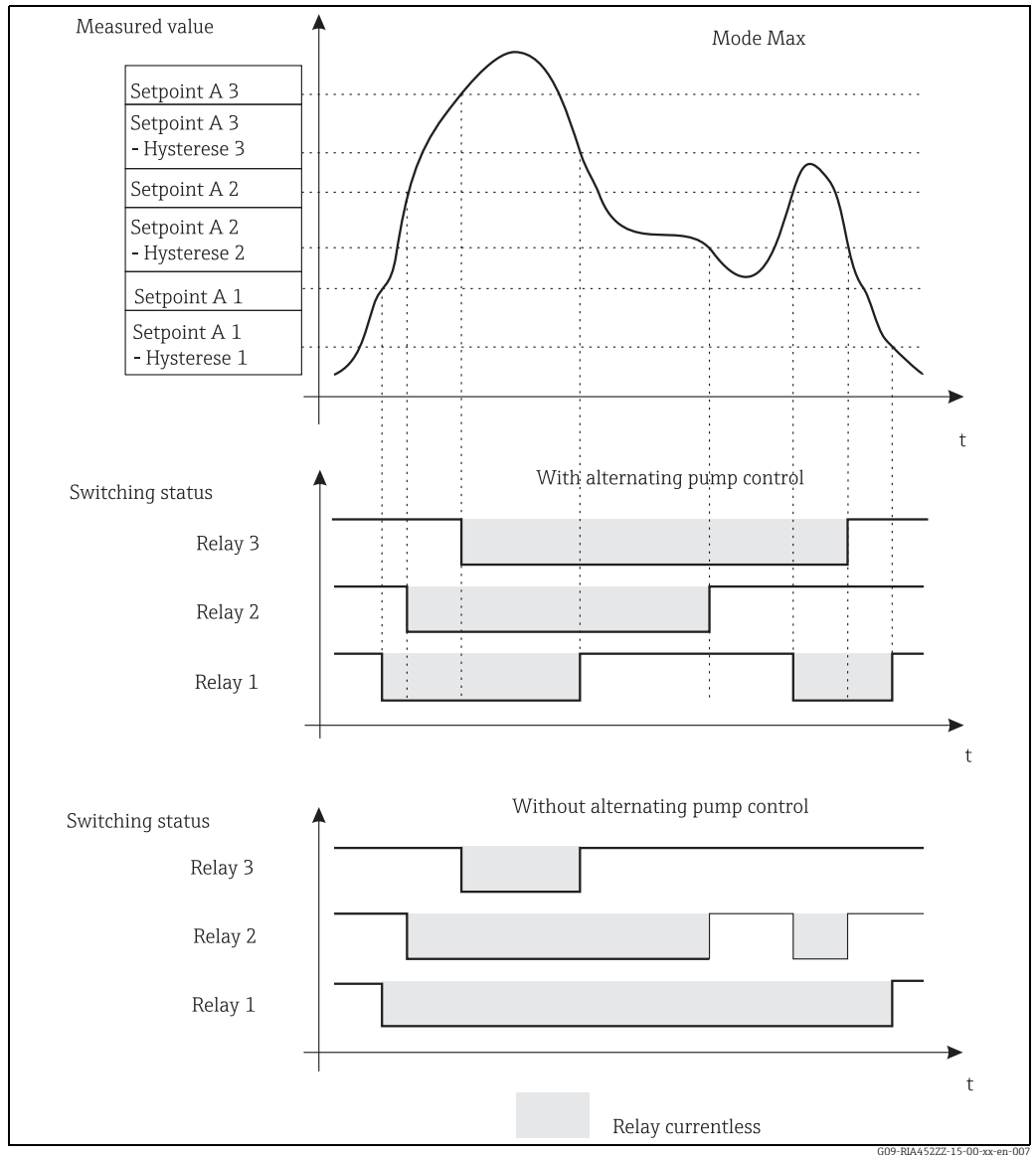

Fig. 19: Alternating pump control

Alternate switching is used to ensure that several pumps are utilized evenly in level control systems. The main factor for switching on a certain pump is not a fixed assigned switch-on value but rather the operating time of the pumps. In total, the first 4 relays (LIMIT 1 to 4) can be included in the alternating pump control system.



Relays not included in alternating pump control are available.

This function cannot be applied to individual relays. Relays not included are not assessed based on the switch-on and switch-off duration.

The following parameters must be configured for the example above:

Menu	Function (menu item)	Setting value
LIMIT 1 to 3/M10 to 12	Each: setpoint A Each: hysteresis Each: alternate	Value for threshold Value for hysteresis Yes

6.3.6 INTEGRATION/M18

This function can only be selected if the pulse output option is available in the device.



If the preset counter function (**Batch**) is used, digital input 1 and relay 1 and 2 are permanently assigned to this function. Configuration for these inputs/outputs is then not possible.

Function (menu item)	Parameter setting	Description
Ref. integr.	Input Lintab	Selects which value should be integrated. <ul style="list-style-type: none"> Input = measured value Lintab = linearized measured value or current flow rate for calculation of channel
Pre-counter	Off Count up Count down	Activation of the preset counter Off = preset counter off Count up = counting up from zero to the end value Count down = counting down from the start value to zero
Integr. base	Off sec Min hour day	Time basis for integration
Dec. factor	XXXXX XXXX.X XXX.XX XX.XXX X.XXXX	Decimal point position of the conversion factor
Factor	0..99999 1.0	Conversion factor
Dimension	XXXXXXXXXX	Select the dimension from the list or dimension as free text (max. 9 characters long).
Dec. point T	XXXXX XXXX.X XXX.XX XX.XXX X.XXXX	Decimal point of totalizer
Set count A	999999 0.0	End value/start value for preset counter; refers permanently to relay 1.
Set count B	999999 0.0	Value for preliminary alarm; refers permanently to relay 2.

Function (menu item)	Parameter setting	Description
Totalizer	9999999	In this position, the totalizer can be displayed and edited (e.g. assigned a default value). The counter starts again at 0 if the maximum value of 9999999 is exceeded.
Reset total	No Yes	Reset totalizer Cannot be configured via ReadWin® 2000.
Calc. flow	No Curve Formula	For selecting a method of calculating the total flow based on the channel type or by means of a formula using the analog input signal (e.g. level signal) <ul style="list-style-type: none"> ■ No = no integration ■ Curve = flow calculated with channel type. If "Curve" is selected, the menu only displays possible channel types for configuration (e.g. Venturi channels, Parshall channels, weirs etc.) ■ Formula = flow calculated using a formula If "Formula" is selected, the menu only displays possible configuration parameters for entering the formula (Alpha, Beta, Gamma, C). Here, the flow is calculated using the following formula: $Q = C * (h^\alpha + g * h^\beta)$
Dim. input	mm inch	Dimension of the channel size
Dec. flow	XXXXX XXXX.X XXX.XX XX.XXX X.XXXX	Decimal point for display
Dim. flow	m ³ /s, l/s, hl/s, igal/s, usgal/s, barrels/s, inch ³ /s, ft ³ /s, Usmgal/s, Ml/s, m ³ /smin, l/ min, hl/min, igal/ min, usgal/min, barrels/min, inch ³ /min, ft ³ / min, Usmgal/min, Ml/min, m ³ /h, l/ h, hl/h, igal/h, usgal/h, barrels/h, inch ³ /h, ft ³ /h, Usmgal/h, Ml/h	Dimension of linearized value <ul style="list-style-type: none"> ■ l = liter ■ hl = hectoliter ■ m³ = cubic meter ■ Ml = megaliter ■ USgal = US gallon ■ USKgal = US kilogallon ■ USMgal = US megagallon ■ USbl = US barrel ■ igal = imperial gallon ■ ibl = imperial barrel ■ inch = inch ■ ft = feet <div style="float: right; text-align: right;"> 1 hl = 100 l 1 m³ = 1,000 l 1 Ml = 1,000,000 l 1 USgal = 3.79 l 1 USKgal = 3,785.41 l 1 USMgal = 3,785,411.78 l 1 USbl = 119.24 l 1 igal = 4.55 l 1 ibl = 163.66 l 1 inch = 25.4 mm 1 ft = 304.8 mm </div>
Dec. point	XXXXX XXXX.X XXX.XX XX.XXX X.XXXX	Decimal point for formula (only if formula-based flow calculation is selected)
Alpha	-99.99999	Flow rate exponent α (see Calc.flow)
Beta	-99.99999	Flow rate exponent β (see Calc.flow)
Gamma	-99.99999	Weighting factor γ
C	-100	Scaling constant C (see Calc.flow)

Function (menu item)	Parameter setting	Description
Flumes weir	Kha Venturi ISO Venturi BST Venturi Parshall Palmer-Bow Rect. WTO Rect WThr NFXRectWTO NFXRectWThr Trap. WTO V-weir BST V-weir NFX V-weir	Kha-Venturi = Khafagi-Venturi channels ISO Venturi = ISO-Venturi channels BST Venturi = Venturi channels as per British Standard Parshall = Parshall channels Palmer-Bow = Parshall-Bowlus channels Rect. WTO = Rectangular weir (w) Rect WThr = Rectangular weir with constriction (w) NFXRectWTO = Rectangular weir as per NFX (w) NFXRectWThr = Rectangular weir as per NFX with constriction (w) Trap. WTO = Trapezoidal weir (w) V-weir = Triangular ("V") weir (w) BST V-weir = Triangular weir as per British Standard NFX V-weir = Triangular weir as per NFX Configure (w) width additionally
Width	99999	Value for width. Can only be selected for channel types marked with (w) (see Flumes-Weir)
Kha-Venturi	QV 302 QV 303 QV 304 QV 305 QV 306 QV 308 QV 310 QV 313 QV 316	Khafagi-Venturi channels QV 302 = Khafagi-Venturi channel QV 302 QV 303 = Khafagi-Venturi channel QV 303 QV 304 = Khafagi-Venturi channel QV 304 QV 305 = Khafagi-Venturi channel QV 305 QV 306 = Khafagi-Venturi channel QV 306 QV 308 = Khafagi-Venturi channel QV 308 QV 310 = Khafagi-Venturi channel QV 310 QV 313 = Khafagi-Venturi channel QV 313 QV 316 = Khafagi-Venturi channel QV 316
ISO Venturi	415 425 430 440 450 480	ISO-Venturi channels 415 = ISO-Venturi channel 415 425 = ISO-Venturi channel 425 430 = ISO-Venturi channel 430 440 = ISO-Venturi channel 440 450 = ISO-Venturi channel 450 480 = ISO-Venturi channel 480
BST Venturi	4" 7" 12" 18" 30"	Venturi channels as per British Standard 4" = Venturi channel as per British Standard 4 in 7" = Venturi channel as per British Standard 7 in 12" = Venturi channel as per British Standard 12 in 18" = Venturi channel as per British Standard 18 in 30" = Venturi channel as per British Standard 30 in
Parshall	1" 2" 3" 6" 9" 1 ft 1.5 ft 2 ft 3 ft 4 ft 5 ft 6 ft 8 ft	Parshall channels 1" = Parshall channel 1 in 2" = Parshall channel 2 in 3" = Parshall channel 3 in 6" = Parshall channel 6 in 9" = Parshall channel 9 in 1 ft = Parshall channel 1 ft 1.5 ft = Parshall channel 1.5 ft 2 ft = Parshall channel 2 ft 3 ft = Parshall channel 3 ft 4 ft = Parshall channel 4 ft 5 ft = Parshall channel 5 ft 6 ft = Parshall channel 6 ft 8 ft = Parshall channel 8 ft

Function (menu item)	Parameter setting	Description
Palmer-Bow.	6" 8" 10" 12" 15" 18" 21" 24" 27" 30"	Palmer-Bowlus channels 6" = Palmer-Bowlus channel 6 in 8" = Palmer-Bowlus channel 8 in 10" = Palmer-Bowlus channel 10 in 12" = Palmer-Bowlus channel 12 in 15" = Palmer-Bowlus channel 15 in 18" = Palmer-Bowlus channel 18 in 21" = Palmer-Bowlus channel 21 in 24" = Palmer-Bowlus channel 24 in 27" = Palmer-Bowlus channel 27 in 30" = Palmer-Bowlus channel 30 in
Rect. WTO	5H T5	Rectangular weirs 5H = rectangular weir WTO/5H T5 = rectangular weir WTO/T5
Rect. WThr	2H 3H 4H 5H 6H 8H TO T5 2T	Rectangular weirs with constriction 2H = rectangular weir with constriction 2H 3H = rectangular weir with constriction 3H 4H = rectangular weir with constriction 4H 5H = rectangular weir with constriction 5H 6H = rectangular weir with constriction 6H 8H = rectangular weir with constriction 8H TO = rectangular weir with constriction TO T5 = rectangular weir with constriction T5 2T = rectangular weir with constriction 2T
NFXRect.WT O	5H T5	Rectangular weir NFX 5H = NFX rectangular weir TO/5H T5 = NFX rectangular weir TO/T5
NFXRect.WThr	2H 3H 4H 5H 6H 8H TO	Rectangular weir NFX with constriction 2H = NFX rectangular weir with constriction 2H 3H = NFX rectangular weir with constriction 3H 4H = NFX rectangular weir with constriction 4H 5H = NFX rectangular weir with constriction 5H 6H = NFX rectangular weir with constriction 6H 8H = NFX rectangular weir with constriction 8H TO = NFX rectangular weir with constriction TO
Trap. W TO	3H T5	Trapezoidal weirs 3H = trapezoidal weir W TO/3H T5 = trapezoidal weir W TO/T5
V-weir	22.5 30 45 60 90	Triangular weirs 22.5 = Triangular weir 22.5 30 = Triangular weir 30 45 = Triangular weir 45 60 = Triangular weir 60 90 = Triangular weir 90
BST V-weir	22.5 45 90	Triangular weir as per British Standard 22.5 = Triangular weir as per British Standard 22.5 45 = Triangular weir as per British Standard 45 90 = Triangular weir as per British Standard 90
NFX V-weir	30 45 60 90	NFX triangular weir 30 = NFX triangular weir 30 45 = NFX triangular weir 45 60 = NFX triangular weir 60 90 = NFX triangular weir 90

Integration function/totalizer

With this function, the computed value from the linearization table, or of the current flow rate for channel calculation or of the analog input can be numerically integrated to create a totalizer for example.

The totalizer is calculated as follows:

$$Totalizer_{new} = Totalizer_{old} + value * \frac{Measuring\ interval}{Integration\ base} * Conversion\ factor$$

The measuring interval is 0.1 s.

In most instances, the integration basis is the same time unit as the time basis of the signal to be integrated.

Example: analog input l/s \Rightarrow integration basis s

Simple preset counter

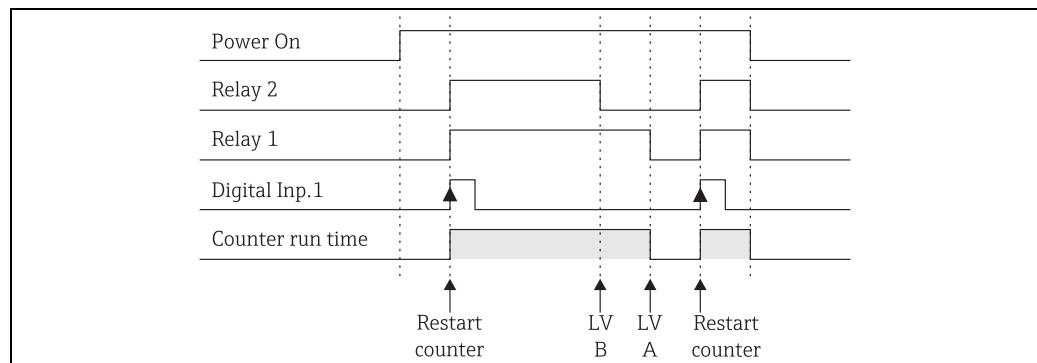

Fig. 20: Simple preset counter

If the preset counter is activated, limit values 1 and 2 are permanently assigned to the preset counter function (output 1 = main switchoff, output 2 = preliminary switchoff). Digital input 1 is permanently assigned to the "Reset and restart preset counter" function.

Thus, the number of free relays available is reduced accordingly. The operating menus for these inputs/outputs are then hidden.

Set count B (LV B) defines the preliminary switchoff, **Set count A** (LV A) defines the main switchoff. Limit value (or start value, see "Pre-counter" function \rightarrow 32) for LV A and preliminary alarm value for LV B are freely configurable

The positive counting direction is defined as follows: starting at the fixed starting value of zero, count up until the set limit value is reached (**Set count A**).

The negative counting direction is defined as follows: starting at the configurable starting value (**Set count A**), count down until the fixed limit value of zero is reached.

The counter is reset and restarted at the same time by means of digital input 1 (**Digital Inp.1**). Edge Digital Inp.1: Low-High = reset and start counter.



The display of the preset counter can be configured under DISPLAY/M2 ... "Ref.num" = "Batch".

Calculation formula for flow measurement

If you selected "Formula" under **Calc. flow** for flow measurement, the flow is calculated using the following formula:

$$Q = C * (h^\alpha + g * h^\beta)$$

Where:

- Q: Flow rate in m³/h
- C: Scaling constant
- h: Headwater level
- α , β : Flow exponent
- γ : Weighting factor



The scaling constant C must always refer to Q in m³/h, i.e. C has to be converted if Q is available in another flow unit.

Examples:

- Q in l/h with C = 2.11
 $1 \text{ l/h} = 0.001 \text{ m}^3/\text{h}$
 $\Rightarrow C = 2.11 * 0.001 = 0.00211$
- Q in USKgal/s with C = 0.35
 $1 \text{ USKgal/s} = 13627.4444 \text{ m}^3/\text{h}$
 $\Rightarrow C = 0.35 * 13627.4444 = 4769.60554$

A table with values for converting the various flow units to m³/h is provided in the appendix.

6.3.7 Pulse output - PULSE OUT/M19

All the possible settings for the pulse output can be found in this menu item. This menu item can only be selected if your device is fitted with this option.

Function (menu item)	Parameter setting	Description
Dec. value	XXXXX XXXX.X XXX.XX XX.XXX X.XXXX	Decimal point position of the pulse value.
Unit value	0..99999 1.0	Pulse value with which the pulses should be output at the output.
Pulse width	0.04 to 2000ms 1000.00	Sets the pulse width at the pulse output. The maximum output frequency depends on the pulse width. $f(\text{max}) = 1/(2 * \text{pulse width})$
Sim pulseout	Off 1 Hz 10 Hz 100 Hz 1000 Hz 10000 Hz	Outputs the selected pulses at the pulse output regardless of the input value. Is automatically set to OFF when exited.

6.3.8 Min/Max memory - MIN MAX/M20

The panel meter can save a minimum and a maximum measured value. The input signal or the signal processed using the linearization table are available as the signal source. The memory is reset manually or using the digital input (→ 24).

Function (menu item)	Parameter setting	Description
Ref. min/max	Input Lintab	Signal source for the min/max value memory. <ul style="list-style-type: none"> ▪ Input = input signal ▪ Lintab = linearized input signal or current flow rate for calculation of channel

Function (menu item)	Parameter setting	Description
Dec. point	XXXXX XXXX.X XXX.XX XX.XXX X.XXXX	Number of digits after the decimal point for the min/max value memory.
Min. value	0..99999	Displays the current minimum value in the memory.
Max. value	0..99999	Displays the current maximum value in the memory.
Reset min	No Yes	Resets the minimum value memory.
Reset max	No Yes	Resets the maximum value memory.

6.3.9 Linearization table - LIN. TABLE/M21

To linearize input variables, a linearization table can be saved in the measuring instrument, e.g. to correct the level signal of a container for volume display.

Function (menu item)	Parameter setting	Description
Counts	2..32 2	Number of support points needed. At least two points have to be entered.
Dimension	XXXXXXXXXX	Select the dimension from the list or dimension as free text (max. 9 characters long).
Dec. Y value	XXXXX XXXX.X XXX.XX XX.XXX X.XXXX	Decimal point position for the Y-values in the linearization table.
Del. points	No Yes	Delete all programmed support points.
Show points	No Yes	Show all programmed support points.

Tank linearization

Example:

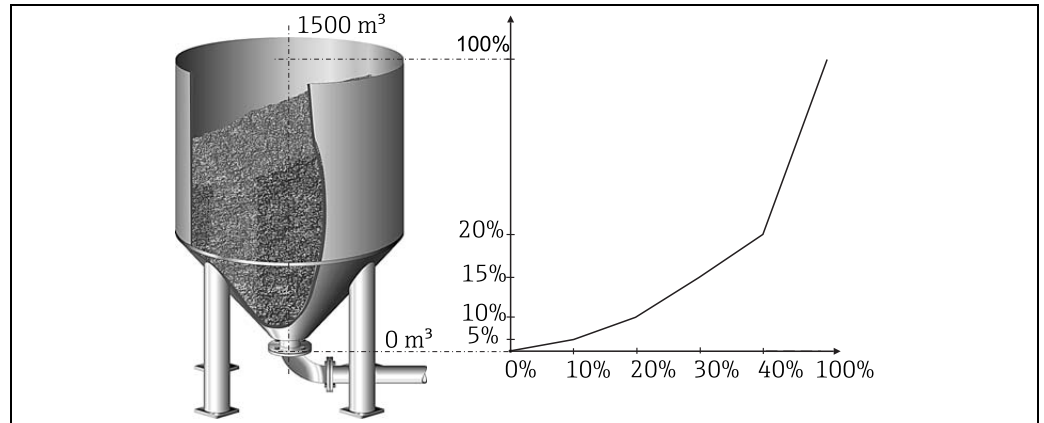

Fig. 21: Example for tank linearization

You want to determine the amount of cereal filled into a silo, display this information on site and transfer it to a process control system. A 4-20 mA level sensor determines the level in the container, the connection between the level (m) and volume (m³) is known and the level is proportional to the sensor current. The volume calculated is output as a 0-20 mA signal at the analog output in proportion to the volume. In the event of a fault in the system, the analog output outputs an error signal of 21.0 mA.

- Container empty:
 - Sensor signal 4 mA
 - Level 0 m
 - Numeric display should show 0 (m³)
 - Bar graph should show 0%
 - 0 mA should be present at the analog output
- Container full:
 - Sensor signal 20 mA
 - Level 10 m
 - Numeric display should show 1500 (m³)
 - Bar graph should show 100%
 - 20 mA should be present at the analog output

	Point									
	1	2	3	4	5	6	7	8	9	10
Sensor signal (mA)	X value 4,0	X value 4,32	X value 4,64	X value 4,96	X value 5,28	X value 5,6	X value 5,92	X value 6,24	X value 6,56	X value 20,0
Display value (m³)	Y value 0	Y value 20	Y value 50	Y value 85	Y value 115	Y value 160	Y value 210	Y value 280	Y value 400	Y value 1500

The following parameters must be configured for the example above:

Menu	Function (menu item)	Setting value
LIN. TABLE / M 21	Counts Dimension Show points	Number of support points (10) Dimension of lin. value (m ³) Display support points (Yes)

Menu	Function (menu item)	Setting value
LINPOINTS 1 to 10 / M23 to 32	Each point Each X value Each Y value	Use point (Used) X-value (as in table above) Y-value (as in table above)
ANALOG OUT / M 3	Ref. num Out range Fail mode Fail value	Output value (lin tab) Signal type (0-20 mA) Failsafe mode (const) Value in event of error (21 mA)
DISPLAY / M 2	Ref. num. Ref. bargraf	Reading on display (lin. table) Signal source for bar graph (lin tab)



The PC operating software supports the generation of a tank linearization table. Here you can find a tank linearization generator which you can use to generate a linearization table for standard and specific tanks.

6.3.10 Support points of linearization table - LINPOINTS 1..X/ M23..MXX

Displays the set value pairs of the linearization table. This menu item is only visible if a linearization table was configured (→ 38) and "Yes" was selected in the "Show points" parameter in the "LIN. TABLE/M21" menu.

Function (menu item)	Parameter setting	Description
Point	Used Discard	Use or discard support point.
X value	-99999..99999	X-value of the linearization table. Corresponds to the input value.
Y value	-99999..99999	Y-value that belongs to the previous X-value. Corresponds to the converted measured value.

6.3.11 Operating parameter - PARAMETER/M55

In this menu item, configuration options such as the user code, failsafe mode of the panel meter to NAMUR etc. can be configured.

Function (menu item)	Parameter setting	Description
User code	9999	The option of editing the operating parameters is locked after entering a 4-digit digital sequence. This lock is indicated on the display with the "key" symbol.
Limit Code	Off On	<ul style="list-style-type: none"> ▪ Off: It is not necessary to enter the user code to change the limit values ▪ On: Limit values are protected by the user code. The item is only displayed if a user code was assigned.
Prog. name	ILU10xA	Displays the name of the device software currently installed.

Function (menu item)	Parameter setting	Description
Version	V X.XX.XX	Version of the device software currently installed.
Func. alt.	Time Count	Setting for controlling pump rotation in alternating pump control. <ul style="list-style-type: none"> Time = switching time of the relay Count = switching frequency of the relay
Lock time	99.9	Locking time of the relay, 0 to 99.9 s
Rel. Mode	Off On	Switching mode of the relays. <ul style="list-style-type: none"> Off = relays de-energize in the event of limit value violation On = relays energize in the event of limit value violation
Grad. Time	1..100	Time setting for gradient evaluation, 1 to 100 s
Namur	No Yes	Sensor evaluation to NAMUR (e.g. cable open circuit). Only for 4 to 20 mA current signal.
Range 1	3.6 (0.0 to 22.0)	Error limits for the input signal. In the "NAMUR=Yes" operating mode, ranges 1 to 4 are assigned the limits specified by Namur NE 43 and cannot be changed. In the "NAMUR=No" operating mode, the error limits can be freely selected. Here, please note that the following applies: Range 1 < Range 2 < Range 3 < Range 4. Violation of these limits can be evaluated with a relay for example ("Alarm" and "Alarm inverse" operating mode).
Range 2	3.8 (0.0 to 22.0)	
Range 3	20.5 (0.0 to 22.0)	
Range 4	21.0 (0.0 to 22.0)	
Contrast	1 to 30	Setting for the display contrast. <ul style="list-style-type: none"> 1 = low contrast 30 = high contrast

7 Maintenance

No special maintenance work is required on the device.

8 Accessories

Name	Order No.
ReadWin® 2000 PC configuration software and serial cable with jack connector 3.5 mm for RS232 port.	RIA452A-VK
ReadWin® 2000 PC configuration software and serial cable for USB port with CDI connector.	TXU10A-xx
IP65 Field housing.	51009957

9 Troubleshooting

The following section provides you with an overview of possible causes of errors to provide you with an initial troubleshooting aid.

9.1 Troubleshooting instructions

⚠ WARNING

Explosion hazard through open device in explosion-hazardous environment

- ▶ In the case of Ex devices, fault diagnosis **cannot** be carried out on the open device as this annuls the explosion protection.

Display	Cause	Remedy
No measured value display	No power supply connected	Check the power supply of the device.
	Power supply applied, device defective	The device must be replaced.
The red marking for overrange/ underrange is flashing on the bar graph.	Analog output is > 10% above or below the scaled range.	Check the scaling of the analog output (Out 100% or Out 0%).



Errors for which an error code is shown on the display are described in Section 9.2. Further information on the display is also provided in Section 5.2.1.

9.2 Process error messages



Faults have the highest priority. The associated error code is displayed. A fault is present if the memory module for writing and reading data is defective or if data could not be read correctly.

9.2.1 Device malfunction

Error code	Cause	Effect	Remedy
E 101	Bus error reading the config/ calibration data after power-up	Faulty device functioning	Instrument error, notify Service
E 102	Implausible operating data (checksum)	Configuration lost	Perform preset
E 103	Implausible calibration data	Faulty device functioning	Instrument error, notify Service
E 104	Bus error reading the min/ max data after power-up	Incorrect min/max values	Reset min/max values
E 105	Bus error reading the relay data after power-up	Incorrect relay data	Reset relay data
E 106	Universal card bus error	Faulty universal input functioning	Replace universal card, notify Service

Error code	Cause	Effect	Remedy
E 210	Pulse output, pulse buffer overflow	A maximum of 10 pulses are buffered	Set the parameters of the pulse output in such a way that the maximum frequency is not exceeded
E 221	Pump error, digital input 1	Relay goes to failsafe mode	Acknowledge error via operation or switching power on/off
E 222	Pump error, digital input 2		
E 223	Pump error, digital input 3		
E 224	Pump error, digital input 4		
E 290	Number overshoot due to decimal point shift	Decimal point position cannot be altered	Check decimal point position and number range



The errors listed above can be evaluated with a relay in the "Alarm" and "Alarm inverse" operating mode.

9.2.2 Incorrect entries

Error code	Description	Reaction at device
E 290	The number of digits after the decimal point cannot be increased due to number overflow of the dependent parameters.	Error code is shown on the display until a key is pressed.

9.3 Spare parts

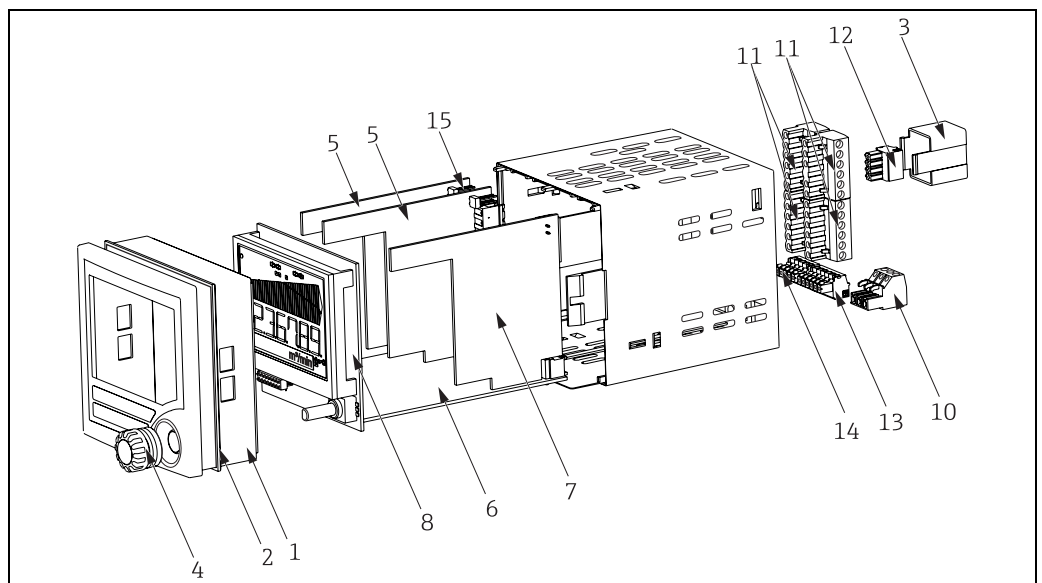

Fig. 22: RIA452 spare parts

G09-RIA452ZZ-09-00-xx-xx-000

Item No.	Name	Order No.
1	Housing front	RIA452X-HA

Item No.	Name	Order No.
2	Housing seal	50070730
3	Ex-cover (rear panel)	51008272
4	Rotary button with seal	RIA452X-HB
5	Relay board	RIA452X-RA
6	Mainboard 90 to 250 V, 50/60 Hz	RIA452X-MA
	Mainboard 20 to 36 V DC; 20 to 28 V AC, 50/60 Hz	RIA452X-MB
	Mainboard 90 to 253 V AC + analog output	RIA452X-MC
	Mainboard 10 to 36 V DC/20-27 V AC + analog output	RIA452X-MD
	Mainboard 90 to 253 V AC + integration + pulse output	RIA452X-ME
	Mainboard 10 to 36 V DC/20-27 V AC + integration + pulse output	RIA452X-MF
	Mainboard 90 to 253 V AC + output + integr. (pulse + analog output)	RIA452X-MG
	Mainboard 10 to 36 V DC + output + integr. (pulse + analog output)	RIA452X-MH
7	Standard input card	RIA452X-IA
	Standard input card ATEX, FM, CSA approval	RIA452X-IB
	Multifunction input card	RIA452X-IC
8	Complete display board	RIA452X-DA
10	Terminal (power supply) 3-pin	50078843
11	Terminal (relay 1-8) 6-pin	51005104
12	Terminal (analog input) 4-pin	51009302
13	Terminal (analog output, Open Collector, transmitter power supply) 6-pin	51008588
14	Terminal (digital inputs) 5-pin	51008587
15	Jumper operating lock	50033350
No Item No.	Casing fixing clip RIA452 (1 piece)	71035359

9.4 Return

For a return, e.g. in case of repair, the device must be sent in protective packaging. The original packaging offers the best protection. Repairs must only be carried out by your supplier's service organization.



Please enclose a note describing the fault and the application when sending the unit in for repair.

9.5 Disposal

The device contains electronic components and must, therefore, be disposed of as electronic waste in the event of disposal. Please observe in particular the local waste disposal regulations of your country.

10 Technical data

10.1 Input

10.1.1 Measured variable

Current (standard)

Digital inputs (standard)

Current/voltage, resistance, resistance thermometer, thermocouples (universal input option)

10.1.2 Measuring ranges

Current input:

- 0/4 to 20 mA +10% overrange, 0 to 5 mA
- Short-circuit current: max. 150 mA
- Input impedance: $\leq 5 \Omega$
- Reaction time: ≤ 100 ms

Universal input:

Current:

- 0/4 to 20 mA +10% overrange, 0 to 5 mA
- Short-circuit current: max. 100 mA
- Input impedance: $\leq 50 \Omega$

Voltage:

- ± 150 mV, ± 1 V, ± 10 V, ± 30 V, 0 to 100 mV, 0 to 200 mV, 0 to 1 V, 0 to 10 V
- Input impedance: ≥ 100 k Ω

Resistance:

- 30 to 3,000 Ω in 3/4 wire technology

Resistance thermometer:

- Pt100/500/1000, Cu50/100, Pt50 in 3/4-wire technology
- Measuring current for Pt100/500/1000 = 250 μ A

Thermocouple types:

- J, K, T, N, B, S, R as per IEC584
- D, C as per ASTM E998
- U, L as per DIN43710/GOST
- Reaction time: ≤ 100 ms

Digital input:

- Voltage level -3 to 5 V low, 12 to 30 V high (as per DIN19240)
- Input voltage max. 34.5 V
- Input current typ. 3 mA with overload and reverse polarity protection
- Sampling frequency max. 10 Hz

10.1.3 Galvanic isolation

Towards all other circuits

10.1.4 Performance characteristics

Reference operating conditions

Power supply: 230 V AC $\pm 10\%$, 50 Hz ± 0.5 Hz

Warm-up period: 90 min

Ambient temperature: 25 $^{\circ}$ C (77 $^{\circ}$ F)

Maximum measured error

Current input:

Accuracy	0.1% of full scale
Resolution	13 bit
Temperature drift	≤ 0.4%/10 K (≤ 0.4%/18 °F)

Universal input:

	Input:	Range:	Maximum measured error of measuring range (oMR):	
Accuracy	Current	0 to 20 mA, 0 to 5 mA, 4 to 20 mA; overrange: to 22 mA	± 0.10%	
	Voltage > 1 V	0 to 10 V, ± 10 V, ± 30 V	± 0.10%	
	Voltage ≤ 1 V	± 1 V, 0 to 1 V, 0 to 200 mV, 0 to 100 mV, ± 150 mV	± 0.10%	
	Resistance thermometer		Pt100, -200 to 600 °C (-328 to 1112 °F) (IEC751, JIS1604, GOST)	4-wire: ± (0.10% oMR + 0.3 K (0.54 °F))
			Pt500, -200 to 600 °C (-328 to 1112 °F) (IEC751, JIS1604)	3-wire: ± (0.15% oMR + 0.8 K (1.44 °F))
			Pt1000, -200 to 600 °C (-328 to 1112 °F) (IEC751, JIS1604)	
Resistance measurement		Cu100, -200 to 200 °C (-328 to 392 °F) (GOST)	4-wire: ± (0.20% oMR + 0.3 K (0.54 °F))	
		Cu50, -200 to 200 °C (-328 to 392 °F) (GOST)	3-wire: ± (0.20% oMR + 0.8 K (1.44 °F))	
		Pt50, -200 to 600 °C (-328 to 1112 °F) (GOST)		
Resistance measurement		30 to 3000 Ω	4-wire: ± (0.20% oMR + 0.3 K (0.54 °F)) 3-wire: ± (0.20% oMR + 0.8 K (1.44 °F))	

Accuracy	Thermocouples	Type J (Fe-CuNi), -210 to 999.9 °C (-346 to 1382 °F) (IEC584)	± (0.15% oMR +0.5 K (0.9 °F)) as of -100 °C (-148 °F) from -100 °C (-148 °F)
		Type K (NiCr-Ni), -200 to 1372 °C (-328 to 2502 °F) (IEC584)	± (0.15% vMB +0.5 K (0.9 °F)) from -130 °C (-234 °F)
		Type T (Cu-CuNi), -270 to 400 °C (-454 to 752 °F) (IEC584)	± (0.15% vMB +0.5 K (0.9 °F)) from -200 °C (-328 °F)
		Type N (NiCrSi-NiSi), -270 to 1300 °C (-454 to 2372 °F) (IEC584)	± (0.15% vMB +0.5 K (0.9 °F)) from -100 °C (-148 °F)
		Type B (Pt30Rh-Pt6Rh), 0 to 1820 °C (32 to 3308 °F) (IEC584)	± (0.15% vMB +1.5 K (2.7 °F)) from 600 °C (1112 °F)
		Type D (W3Re/W25Re), 0 to 2315 °C (32 to 4199 °F) (ASTME998)	± (0.15% vMB +1.5 K (2.7 °F)) from 500 °C (932 °F)
		Type C (W5Re/W26Re), 0 to 2315 °C (32 to 4199 °F) (ASTME998)	± (0.15% vMB +1.5 K (2.7 °F)) from 500 °C (from 932 °F)
		Type L (Fe-CuNi), -200 to 900 °C (-328 to 1652 °F) (DIN43710, GOST)	± (0.15% vMB +0.5 K (0.9 °F)) from -100 °C (-148 °F)
		Type U (Cu-CuNi), -200 to 600 °C (-328 to 1112 °F) (DIN 43710)	± (0.15% vMB +0.5 K (0.9 °F)) from -100 °C (-148 °F)
		Type S (Pt10Rh-Pt), 0 to 1768 °C (32 to 3214 °F) (IEC584)	± (0.15% vMB +3.5 K (6.3 °F)) for 0 to 100 °C (32 to 212 °F) ± (0.15% vMB +1.5 K (2.7 °F)) for 100 to 1768 °C (232 to 3214 °F)
	Type R (Pt13Rh-Pt), -50 to 1768 °C (-58 to 4199 °F) (IEC584)	± (0.15% vMB +3.5 K (6.3 °F)) for 0 to 100 °C (32 to 212 °F) ± (0.15% vMB +1.5 K (2.7 °F)) for 100 to 1768 °C (232 to 3214 °F)	
Resolution	16 bit		
Temperature drift	Temperature drift: ≤ 0.1%/10 K (0.1%/18 °F)		

Current output:

Linearity	0.1% of full scale
Resolution	13 bit
Temperature drift	≤ 0.1%/10K (0.1%/18 °F)
Output ripple	10 mV at 500 Ω for frequencies ≤ 50 kHz

Voltage output

Linearity	0.1% of full scale
Resolution	13 bit
Temperature drift	≤ 0.1%/10K (0.1%/18 °F)

10.1.5 Power supply

Electrical connection

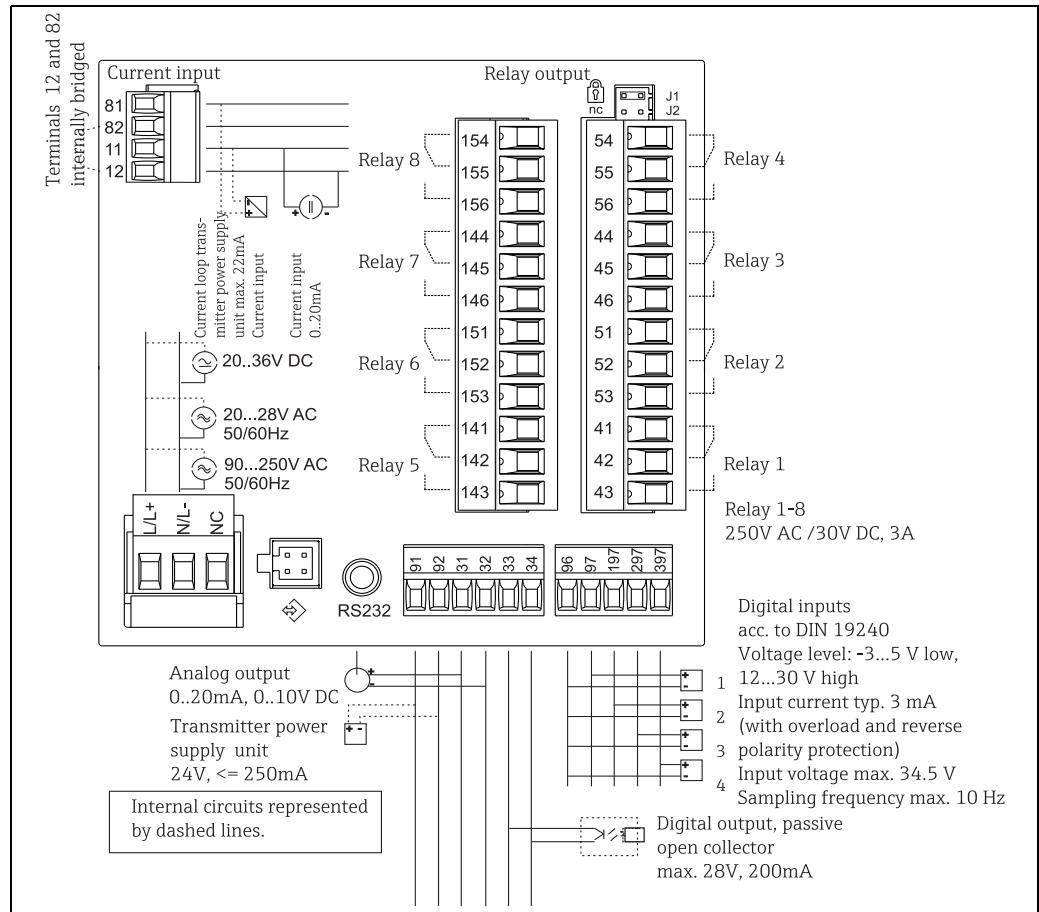

Fig. 23: Terminal assignment of panel meter

G09-RIA452ZZ-04-01-xo-en-000

Universal input option

The device can be optionally equipped with a universal input instead of a current input.

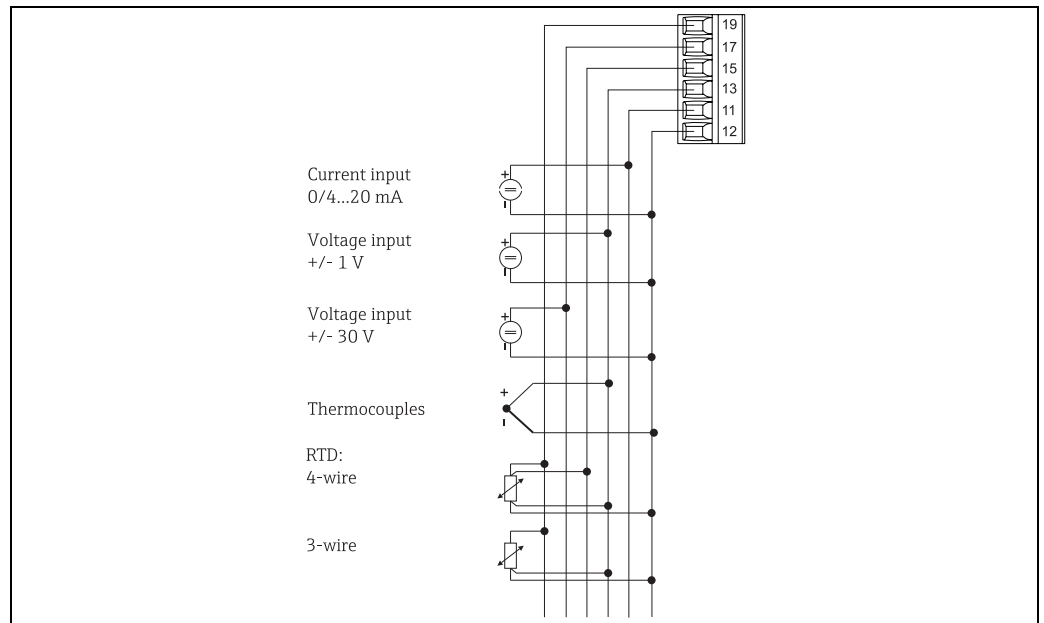

Fig. 24: Universal input terminal assignment

Supply voltage

Low voltage power unit 90 to 250 V AC 50/60 Hz

Extra-low voltage power unit: 20 to 36 V DC or 20 to 28 V AC 50/60 Hz

Power consumption

Max. 24 VA

Connection data interface

RS232

- Connection: jack socket 3.5 mm, rear of device
- Transmission protocol: ReadWin® 2000
- Transmission rate: 38,400 Baud

10.2 Output

10.2.1 Output signal

Relay, transmitter power supply (standard)

Current, voltage, pulse, intrinsically safe transmitter power supply (option)

10.2.2 Signal on alarm

No measured value visible on the LC display, no background illumination, no sensor power supply, no output signals, relays behave in safety-oriented manner.

10.2.3 Current/voltage output

Span:

- 0/4 to 20 mA (active), 0 to 10 V (active)

Load:

- $\leq 600 \Omega$ (current output)
- Max. loop current 22 mA (voltage output)

Signal characterization:

- Signal freely scalable

Galvanic isolation towards all other circuits

10.2.4 Pulse output

- Frequency range to 12.5 kHz
- $I_{\max} = 200 \text{ mA}$
- $U_{\max} = 28 \text{ V}$
- $U_{\text{low}/\max} = 2 \text{ V}$ at 200 mA
- Pulse width = 0.04 to 2000 ms

10.2.5 Relay

Signal characterization:

- Binary, switches when the limit value is reached

Switch function: limit relay switches for the operating modes:

- Minimum/maximum safety
- Alternating pump control function
- Batch function
- Time control
- Window function
- Gradient
- Device malfunction
- Sensor malfunction

Switching threshold:

- Freely programmable

Hysteresis:

- 0 to 99%

Signal source:

- Analog input signal
- Integrated value
- Digital input

Number:

- 4 in basic unit (can be extended to 8 relays, option)

Electrical specifications:

- Relay type: changeover
- Relay switching capacity: 250 V AC / 30 V DC, 3 A
- Switch cycles: typically 10^5
- Switching frequency: max. 5 Hz
- Minimum switching load: 10 mA / 5 V DC

Galvanic isolation towards all other circuits



Mixed assignment of low and extra-low voltage circuits is not permitted for neighboring relays.

10.2.6 Transmitter power supply

Transmitter power supply 1, terminal 81/82 (optionally intrinsically safe):

Electrical specifications:

- Output voltage: $24 \text{ V} \pm 15\%$
- Output current: max. 22 mA (at $U_{\text{out}} \geq 16 \text{ V}$, sustained short-circuit proof)

- Impedance: $\leq 345 \Omega$

Approvals:

- ATEX
- FM
- CSA

Transmitter power supply 2, terminal 91/92:

Electrical specifications:

- Output voltage: $24 \text{ V} \pm 15\%$
- Output current: max. 250 mA (sustained short-circuit proof)

Transmitter power supply 1 and 2:

Galvanic isolation

- Towards all other circuits

HART[®]:

- HART[®] signals are not impaired

10.3 Installation

10.3.1 Installation instructions

Mounting location

Panel, cutout 92 x 92 mm (3.62x3.62 in) (see 'Mechanical construction').

Orientation

Horizontal +/- 45° in every direction

10.3.2 Environment

Ambient temperature range

-20 to +60 °C (-4 to 140 °F)

Storage temperature

-30 to +70 °C (-22 to 158 °F)

Operating height

< 3000 m above MSL (9800 ft)

Climate class

As per IEC 60654-1, Class B2

Condensation

Front: permitted

Device casing: not permitted

Degree of protection

Front IP 65 / NEMA 4

Device casing IP 20

Shock and vibration resistance

2(+3/-0) Hz - 13.2 Hz: $\pm 1.0 \text{ mm}$

13.2 Hz - 100 Hz: 0.7 g

Electromagnetic compatibility (EMC)

- Interference immunity:
To IEC 61326 industrial environments / NAMUR NE 21
- Interference emissions:
To IEC 61326 Class A

10.4 Mechanical construction

10.4.1 Design, dimensions

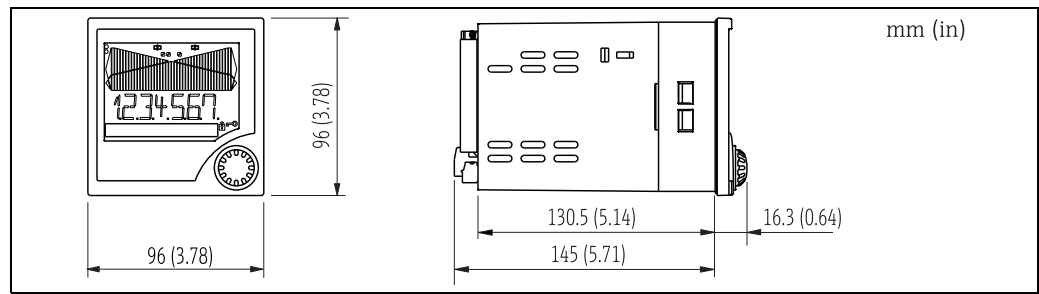

Fig. 25: Dimensions of the panel meter

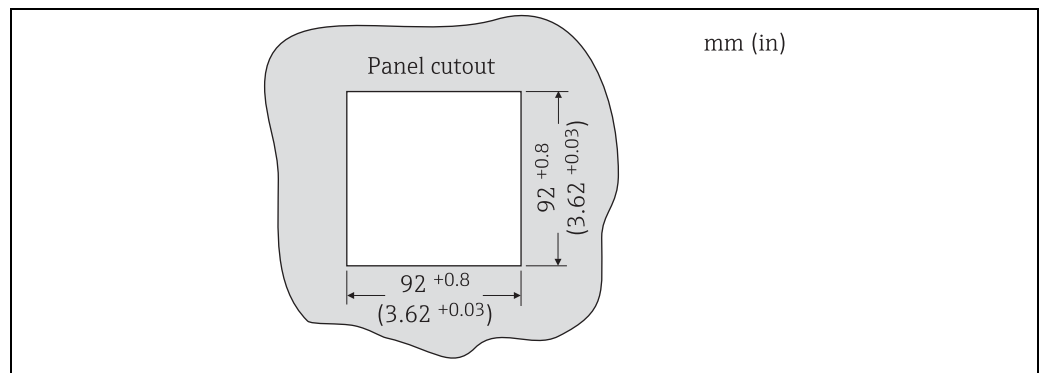

Fig. 26: Panel cutout

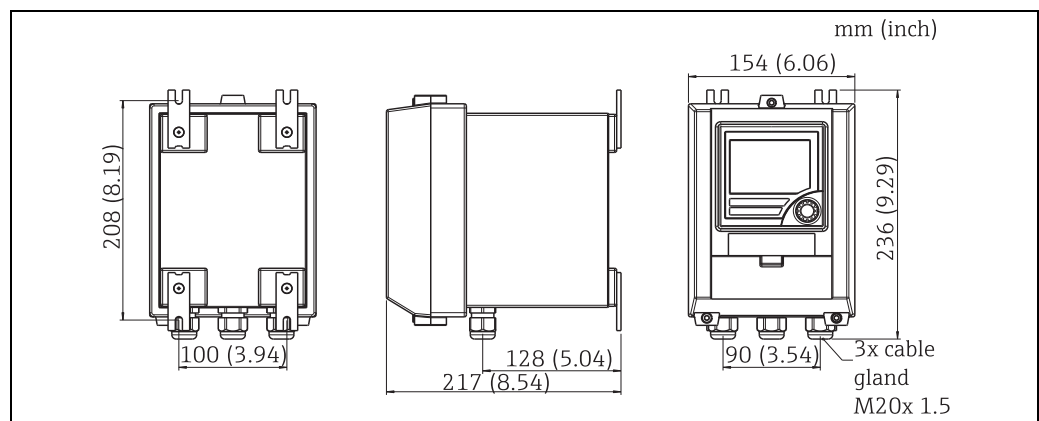

Fig. 27: Dimensions of field housing

10.4.2 Weight

Approx. 500 g (17.64 oz)

10.4.3 Material

- Housing front: ABS plastic, galvanized
- Housing casing: plastic PC10GF

10.4.4 Terminals

Pluggable screw terminals, core size 1.5 mm² (16 AWG) solid, 1.0 mm² (18 AWG) strand with wire ferrule

10.5 Human interface

10.5.1 Display elements

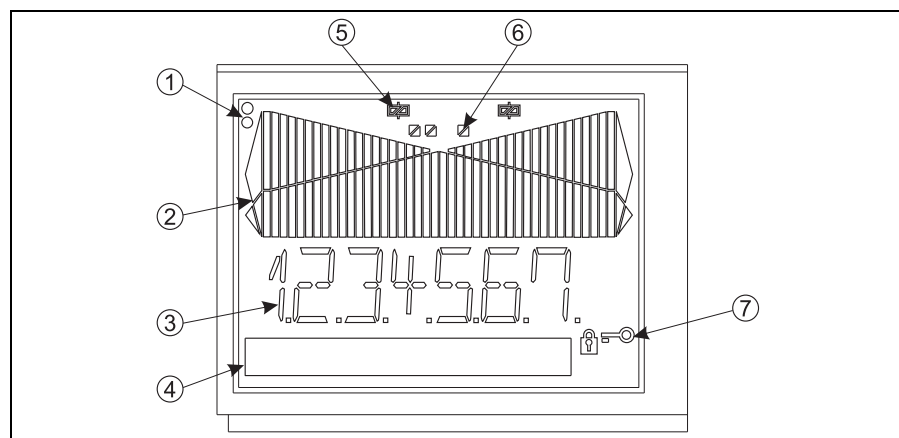

Fig. 28: LC display of panel meter

- Item 1: Device status LEDs: green - device ready for operation; red - device or sensor malfunction
 Item 2: Bar graph with overrange and underrange
 Item 3: 7-digit 14-segment display
 Item 4: Unit and text field 9x77 dot matrix
 Item 5: Relay status display: if power is supplied to a relay, the symbol is displayed
 Item 6: Status display, digital inputs
 Item 7: Symbol for 'device operation blocked'

- Display range
 - 99999 to +99999 for measured values
 - 0 to 9999999 for counter values
- Signaling
 - Relay activation
 - Measuring range overshoot/undershoot

10.5.2 Operating elements

Jog/shuttle dial

10.5.3 Remote operation

Configuration

The device can be configured with the PC software ReadWin[®] 2000.

Interface

CDI interface at device; connection to PC via USB box (see 'Accessories')

RS232 interface at device; connection with serial interface cable (see 'Accessories')

10.6 Certificates and approvals

10.6.1 CE mark

The device meets the legal requirements of the EU directives. Endress+Hauser confirms that the device has been tested successfully by affixing the CE mark.

10.6.2 Ex approval

Information about currently available Ex versions (ATEX, FM, CSA, etc.) can be supplied by your E+H Sales Center on request. All explosion protection data are given in a separate documentation which is available upon request.

10.6.3 Other standards and guidelines

- IEC 60529
Degrees of protection by housing (IP code)
- IEC 61010-1
Protection measures for electrical equipment for measurement, control, regulation and laboratory procedures
- CSA 1010.1
Safety requirements for electrical equipment for measurement, control, and laboratory use
- General requirements
- FM 3610
Intrinsically safe apparatus and associated apparatus for use in class 1, 2 and 3, division 1 hazardous (classified) locations
- CSA C22.2.157
Intrinsically safe & non-incendive equipment for use in hazardous locations
- CSA E79-11
Electrical apparatus for explosive gas atmospheres - intrinsic safety "I"
- EN 50020
Electrical apparatus for hazardous areas - intrinsic safety "I"

10.7 Documentation

- System components - Indicators, interface devices, surge arresters, energy and application managers, data managers, paperless recorders and associated software packages for process automation (FA00016K/09/en)
- Supplementary Ex documentation:
ATEX II(1)GD: XA053R/09/a3

11 Appendix

11.1 Flow conversion

Conversion of various units to m³/h

Liter

- 1 l/s = 3.6 m³/h
- 1 l/min = 0.06 m³/h
- 1 l/s = 0.001 m³/h

Hectoliter

- 1 hl/s = 360 m³/h
- 1 hl/min = 6 m³/h
- 1 hl/h = 0.1 m³/h

Cubic meter

- 1 m³/s = 3600 m³/h
- 1 m³/min = 60 m³/h

Megaliter

- 1 Ml/s = 3,600,000 m³/h
- 1 Ml/min = 6,000 m³/h
- 1 Ml/h = 1000 m³/h

US gallon

- 1 USgal/s = 13.6274 m³/h
- 1 USgal/min = 0.2271 m³/h
- 1 USgal/h = 0.003785 m³/h

US kilogallon

- 1 US Kgal/s = 13627.4444 m³/h
- 1 US Kgal/min = 227.1241 m³/h
- 1 US Kgal/h = 3.7854 m³/h

US megagallon

- 1 USMgal/s = 13,627,481.6155 m³/h
- 1 USMgal/min = 227,124.6936 m³/h
- 1 USMgal/h = 3785.4118 m³/h

US Barrel

- 1 US bl/s = 429.264 m³/h
- 1 US bl/min = 7.1544 m³/h
- 1 US bl/h = 0.1192 m³/h

Imperial gallon

- 1 Imp. gal/s = 16.3659 m³/h
- 1 Imp gal/min = 0.2728 m³/h
- 1 Imp gal/h = 0.004546 m³/h

Imperial barrel

- 1 Imp. bl/s = 589.1955 m³/h
- 1 Imp. bl/min = 9.8195 m³/h
- 1 Imp. gal/h = 0.1637 m³/h

Cubic inch

- 1 in³/s = 0.05899 m³/h
- 1 in³/min = 0.00098322 m³/h
- 1 in³/h = 0.000016387 m³/h

Cubic foot

- 1 ft³/s = 101.9406 m³/h
- 1 ft³/min = 1.699 m³/h
- 1 ft³/h = 0.0283 m³/h

Index

Numerics

0% value (function)	21
100% value (function)	21
24-hour activation function	30

A

Adjusting the analog input	22
Alpha (function)	33
Alternate	31
Alternate (function)	27
Alternating pump control	31
Analog input	
Adjusting	22
Parameter	20
Analog output	
Parameter	23

B

Bar 0% (function)	22
Bar 100% (function)	22
Bar rise (function)	23
Beta (function)	33
BST Venturi (function)	34
BST V-weir (function)	35

C

C (function)	33
Calc. flow (function)	33
Certificates and approvals	54
Comp. Temp (function)	21
Configuration	
Operating parameter	40
Connecting external sensors	12
Current input	12
Universal input	13
Connecting the power supply	12
Connection (function)	21
Const. temp (function)	21
Contrast (function)	41
Count (function)	27
Counts (function)	38
Current input	
Connecting external sensors	12
Curve (function)	21

D

Damp (function)	21
Dec. factor (function)	32
Dec. flow (function)	33
Dec. point (function)	21-23, 27, 33, 38
Dec. value (function)	37
Dec. Y value (function)	38
Dec. point T (function)	32
Del. points (function)	38
Delay	30
Delay (function)	27
Device malfunction	42

Digital input

Parameter	24
Dim. flow (function)	33
Dim. input (function)	33
Dimension (function)	21, 32, 38
Dimensions	7
Disabling	
Configuration	19
Disabling the programming mode	19
Display	17
Parameter	22
Display sw. (function)	22
Documentation	54

E

Electrical connection	
Post-connection check (checklist)	13
Entering text	18
Error codes	42-43

F

Factor (function)	32
Fail mode (function)	23
Fail value (function)	23
Flow measurement	
Formula for calculation	36
Scaling constant	37
Flumes Weir (function)	34
Func. alt. (function)	41
Function	24, 27

G

Gamma (function)	33
Grad. Time (function)	41

H

Hardware locking	19
Human interface	53
Hysteresis (function)	27

I

Incorrect entries	43
Input	45
Installation	51
Integr. base (function)	32
Integration	
Parameter	32
Integration (function)	32
Integration function	36
ISO Venturi (function)	34

K

Kha-Venturi (function)	34
------------------------------	----

L

Level (function)	24
Limit code (function)	40

Limit values		Linearization table	38
Parameter	26	Min/max memory	37
Linearization function	39	Pulse output	37
Linearization table		Support points	40
Parameter	38	Parshall (function)	34
Lock time (function)	41	Performance characteristics	45
M		Point (function)	40
Max. value (function)	38	Power supply	12, 48
Mechanical construction	52	Pre-counter (function)	32
Menu		Preset counter	36
Analog Out	23	Prog. name (function)	40
Digital Inp.	24	Pulse output	
Display	22	Parameter	37
Input	20	Pulse width (function)	37
Limit	26	Pump monitoring function	25
LIN. Table	38	R	
LINPOINTS 1..X	40	Range 1 (function)	41
MIN MAX	37	Range 2 (function)	41
PARAMETER	40	Range 3 (function)	41
Pulse out	37	Range 4 (function)	41
Min. value (function)	38	Rect.WThr (function)	35
Min/max memory		Rect.WTO (function)	35
Parameter	37	Ref. bargraf (function)	22
Mounting location	7	Ref. integr. (function)	32
N		Ref. Min/Max (function)	37
Nameplate	6	Ref. num. (function)	22-23, 27
Namur (function)	41	Rel. Mode (function)	41
NFX V-weir (function)	35	Repairs	4, 44
NFXRect.WThr (function)	35	Reset (function)	28
NFXRect.WTO (function)	35	Reset max (function)	38
O		Reset min (function)	38
Offset (function)	21, 23	Runtime (function)	27
Open circ. (function)	21	S	
Operating matrix	14	Sampl. time (function)	24
Operating mode		Scaling the analog input	22
Alarm	29	Sensors	
Grad	29	Connecting external -	12
Max	28	Set count A (function)	32
Min	28	Set count B (function)	32
Operating parameter		Setpoint A (function)	27
Configuration	40	Setpoint B (function)	27
Orientation	7	Show points (function)	38
Out 0% (function)	23	Signal type (function)	20
Out 100% (function)	23	Sim pulseout (function)	37
Out damp (function)	23	Simu mA (function)	24
Out range (function)	23	Simu relay (function)	28
Output	49	Simu V (function)	24
P		Support points	
Palmer-Bow. (function)	35	Parameter	40
Parameter		Sw. delay (function)	27
Analog input	20	Sw. period (function)	27
Analog output	23	T	
Digital input	24	Tank linearization	39
Display	22	Technical data	
Integration	32	Certificates and approvals	54
Limit values	26	Documentation	54
		Human interface	53

Input	45
Installation	51
Mechanical construction	52
Output	49
Performance characteristics	45
Power supply	48
Terminal assignment	9
Text entry	18
Totalizer	36
Totalizer (function)	33
Trap. W TO (function)	35
U	
Unit value (function)	37
Units	
Conversion	55
Universal input	
Connecting external sensors	13
User code	19
User code (function)	40
V	
Version (function)	41
V-weir (function)	35
W	
Width (function)	34
X	
X value (function)	40
Y	
Y value (function)	40

www.addresses.endress.com



Visit us at Transcat.com 

sales@transcat.com 1.800.828.1470

