

Technical Information

RIA14

Loop powered field indicator



With explosion proof enclosure (according to Ex d)

Application

- Oil & gas
- Petrochemical industry
- System and apparatus engineering
- Outdoor applications
- Laboratory facilities
- Process data acquisition and monitoring
- Optional: stainless steel housing

Your benefits

- Loop-powered indicator in single compartment housing
- 5-digit LC display, character height 20.5 mm (0.8")
- Illuminated display, rotatable in 90° steps
- Trend bargraph in increments of 10%
- Measuring range display from -19999 to 99999
- Digital limit switch
- Freely programmable units
- 3-key operation
- Approvals: ATEX, IECEx, FM, CSA, TIIS, UL listed, GL marine certificate
- 3 cable entries
- Configuration with FieldCare PC software
- Configuration without power supply using setup box

Function and system design

Measuring principle

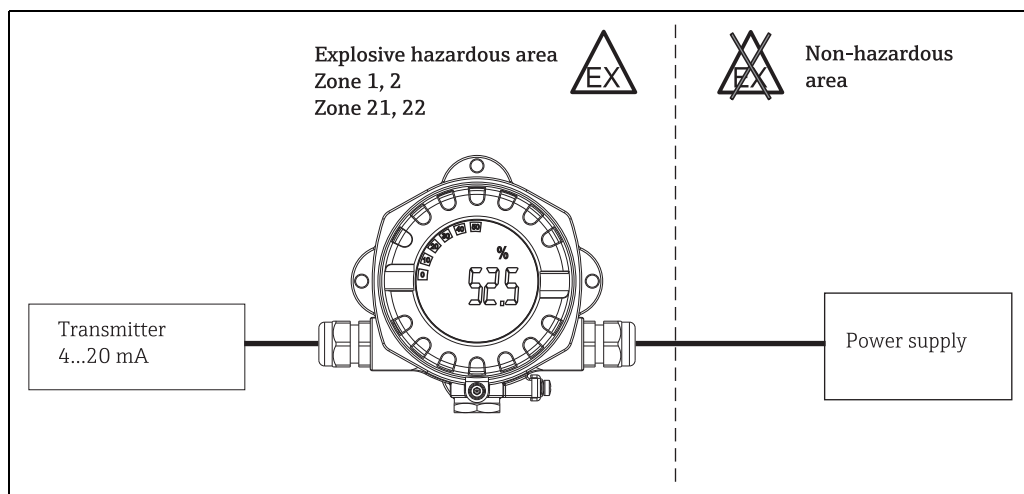

Example of an application of the field indicator

The indicator records an analog measuring signal and shows this on the display. The LC display shows the current measured value digitally and as a bargraph with limit value violation signalling. The indicator is looped into the 4 to 20 mA circuit and obtains the required energy from there.

Measuring system

Microcontroller controlled indicator in single chamber field housing with illuminated LC display. The measuring range, decimal point and offset of the indicator can be configured comfortably by means of three keys in the device with the housing open or by means of a PC with the FieldCare PC software.

Input

Measured variable

Current

Measuring range

4 to 20 mA (reverse polarity protection)

Output

Output signal

Digital limit switch
Passive, open collector:
 $I_{\max} = 200 \text{ mA}$
 $U_{\max} = 35 \text{ V}$
 $U_{\text{low/max}} = < 2 \text{ V at } 200 \text{ mA}$
Max. reaction time to limit value = 250 ms
Temperature range: -20 to +80 °C (-4 to +176 °F)

Signal on alarm

- No measured value visible on the LC display, no background illumination.
- Open Collector inactive.

Transmission behavior

The indicator allows the HART[®] transmission protocol to pass unimpeded.

Power supply

Terminal assignment

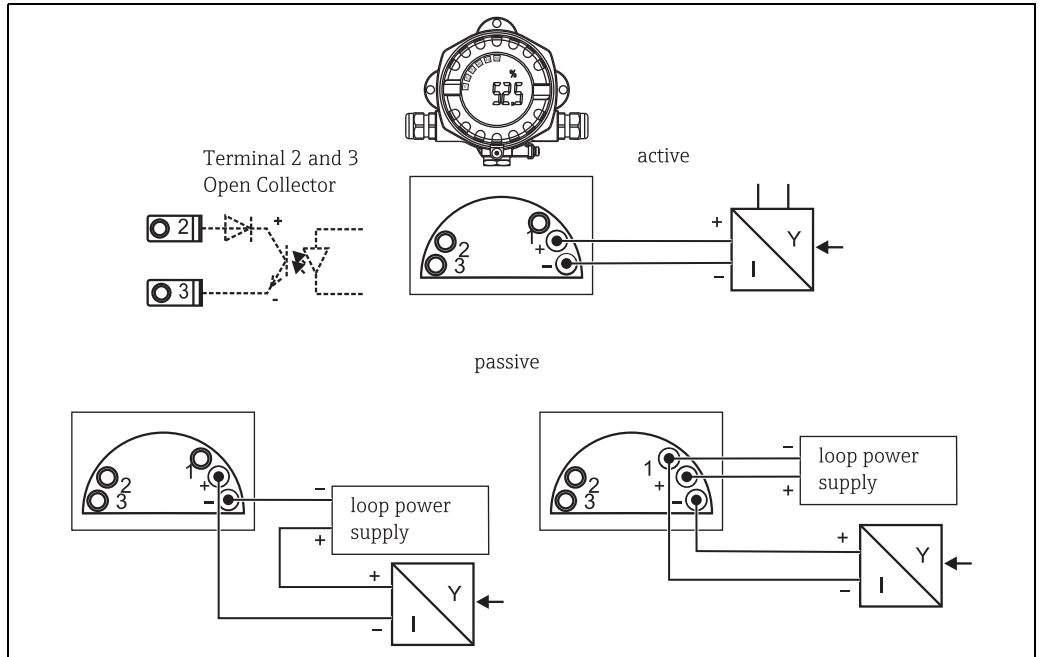

a0010946-en

Terminal assignment of the field indicator

Terminal	Terminal assignment	Input and output
+	Measuring signal (+) 4 to 20 mA	Signal input
-	Measuring signal (-) 4 to 20 mA	Signal input
1	Terminal for further instrumentation	Support terminal
2	Digital limit switch (collector)	Switch output
3	Digital limit switch (emitter)	Switch output

Supply voltage Supply by means of the 4 to 20 mA current loop.

Voltage drop

- Line voltage drop < 3.6 V at 3 - 22 mA
- Max. line voltage drop < 6 V at max. short-circuit current 200 mA

Terminals Cables / wires up to max. 2.5 mm² (14 AWG) plus ferrule

Cable entry The following cable entries are available:

- Thread NPT1/2
- Thread M20
- Thread G1/2
- 2x gland NPT1/2 + 1x blind plug
- 2x gland M20 + 1x blind plug

Performance characteristics

Reference operating conditions	T= 25 °C (77 °F)
Maximum measured error	< 0.1% of scaled display range
Influence of ambient temperature	Effect on the accuracy when ambient temperature changes by 1 K (1.8 °F): 0.01%

Installation

Mounting location	Wall or pipe mounting (see 'Accessories')
Orientation	No restrictions, the orientation is determined by the readability of the display.

Environment

Ambient temperature range	-40 to +80 °C (-40 to +176 °F) -20 to +80 °C (-4 to +176 °F) when the Open Collector output is used  The display can react slowly for temperatures < -20 °C (< -4 °F). Readability of the display cannot be guaranteed at temperatures < -30 °C (-22 °F).
Storage temperature	-40 to +80 °C (-40 to +176 °F)
Electrical safety	As per IEC 61010-1, UL61010-1, CSA C22.2 No. 1010.1-92
Climate class	As per IEC 60 654-1, Class C
Degree of protection	IP 67, NEMA 4X (not evaluated by UL)
Shock and vibration resistance	3g / 2 to 150 Hz as per IEC 60 068-2-6
Condensation	Permitted
Installation category	1 to IEC 61010
Pollution degree	2 to IEC 61010
Electromagnetic compatibility (EMC)	<ul style="list-style-type: none"> ▪ EN 61326 (IEC 61326): Electromagnetic compatibility (EMC requirements) ▪ NAMUR (NE21): Association for Standards for Control and Regulation in the Chemical Industry

Mechanical construction

Design, dimensions

Die cast aluminum housing for general purpose or as option stainless steel housing

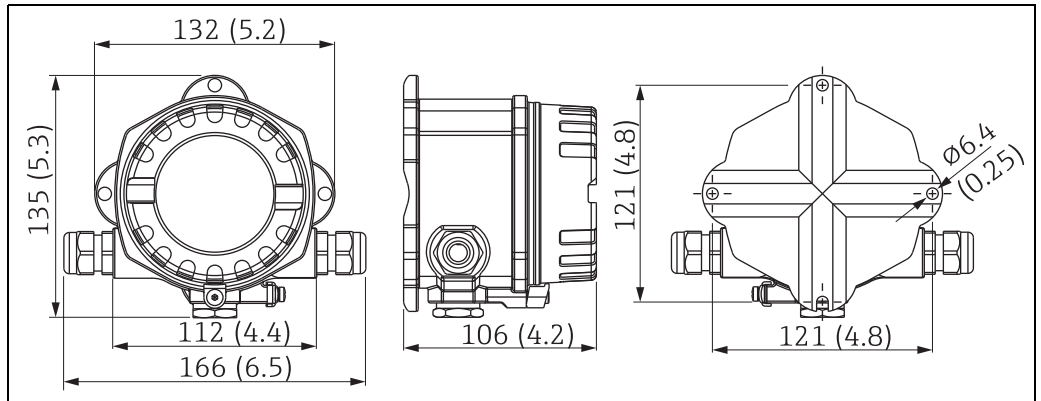

Data in mm (data in inches in brackets)

- Electronics compartment and connection compartment together in the single chamber housing
- Display can be rotated in 90°-stages

Weight

- Approx. 1.6 kg (3.53 lb) (aluminium housing)
- Approx. 4.2 kg (9.26 lb) (stainless steel housing)

Material

Housing	Nameplate
Die-cast aluminum AlSi10Mg with powder coating on polyester basis	Aluminum AlMg1, anodized in black
Stainless steel 1.4435 (AISI 316L), as an option	1.4401 (AISI 316)

Operability

Local operation

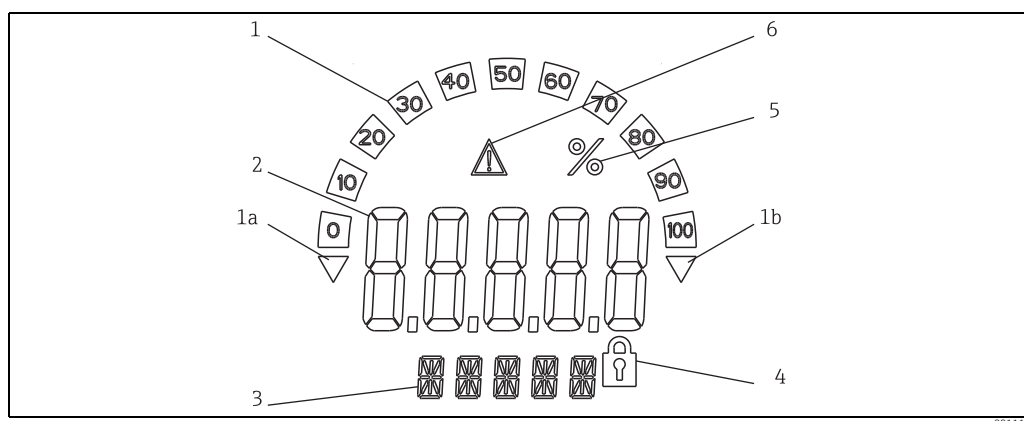

LC display of the field indicator (illuminated, pluggable in 90° stages)

Item 1: bargraph display in increments of 10% with indicators for measuring range undershoot (item 1a)/overshoot (item 1b)

Item 2: measured value display, character height 20.5 mm (0.8")

Item 3: 14-segment display for units and information messages

Item 4: symbol "programming disabled"

Item 5: unit "%"

Item 6: warning symbol "failure"

- Display range
-19999 to +99999
- Offset
-19999 to +99999
- Signalling
Measuring range overshoot/undershoot
- Limit value violation
Lower/upper limit value exceeded

Operating elements

3-key operation (-/+/E) integrated in device, access with housing open

Remote operation

Configuration

The device is configured with the FieldCare PC operating software. FieldCare Device Setup forms part of the scope of supply of Commubox FXA291 or TXU10-AC (see 'Accessories') or can be downloaded free of charge from the Internet at www.endress.com.

Interface

Configuration interface at device; connection to PC via configuration cable (see "Accessories").

Configurable device parameters (selection)

Measuring dimension, measuring ranges (linear/square), setup block using user code, failsafe mode, digital filter (damping), offset, limit value (min/max/alarm), alarm limit values freely adjustable.

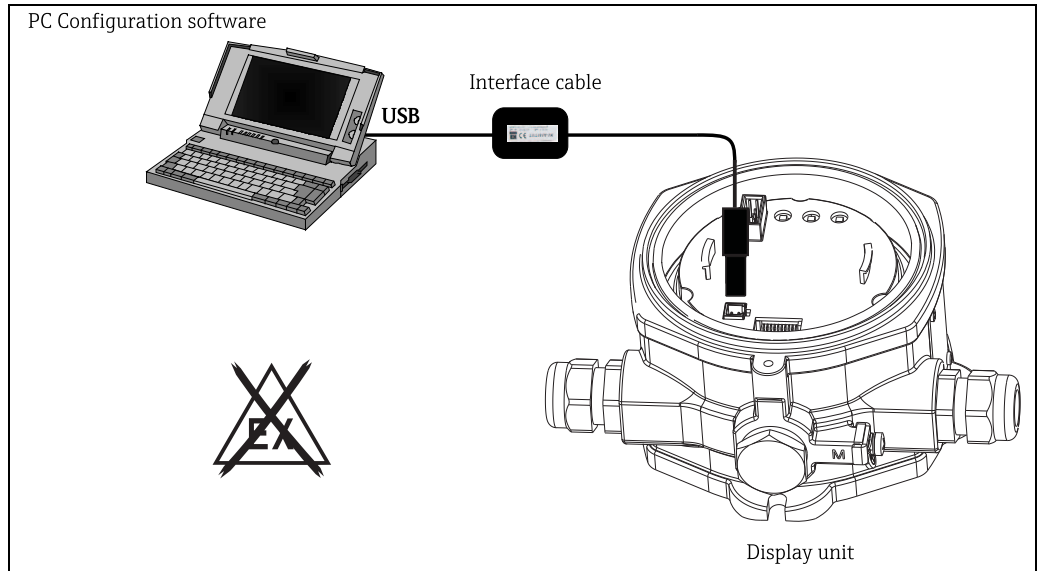

Configuration with PC operating software.

Certificates and approvals

CE mark	The device complies with the legal requirements of the EC directives. Endress+Hauser confirms that the device has been successfully tested by affixing to it the CE mark.
Ex approvals	Information about currently available Ex versions (ATEX, FM, CSA, etc.) can be supplied by your E+H Sales Center on request. All explosion protection data are given in a separate documentation which is available upon request.
Marine approval	Germanischer Lloyd marine certificate
Other standards and guidelines	<ul style="list-style-type: none"> ■ IEC 60529: Degree of protection by housing (IP-Code) ■ IEC 61010-1: Safety requirements for electrical measurement, control and laboratory instrumentation. ■ IEC 61326-series: Electrical equipment for measurement, control and laboratory use - EMC requirements. ■ NAMUR: User association of automation technology in process industries (www.namur.de) ■ NEMA: Standardization association for the electrical industry in North America.
UL	Recognized component to UL 3111-1
CSA GP	CSA General Purpose

Ordering information

Detailed ordering information is available from the following sources:

- In the Product Configurator on the Endress+Hauser website: www.endress.com → Select country → Instruments → Select device → Product page function: Configure this product
- From your Endress+Hauser Sales Center: www.endress.com/worldwide



Product Configurator - the tool for individual product configuration

- Up-to-the-minute configuration data
- Depending on the device: Direct input of measuring point-specific information such as measuring range or operating language
- Automatic verification of exclusion criteria
- Automatic creation of the order code and its breakdown in PDF or Excel output format
- Ability to order directly in the Endress+Hauser Online Shop

Accessories

Accessories

Order No.	Name
FXA291	Commubox FXA291 incl. FieldCare Device Setup and DTM library
TXU10-AC	Commubox TXU10 incl. FieldCare Device Setup and DTM library

Documentation

- Overview brochure: System components: FA00016K/09
- Operating Instructions for 'RIA14 field indicator': BA00278R/09
- Supplementary Ex documentation:
 - ATEX II2(1)G EX ib[ia] IIC T6/T5/T4: XA090R/09/a3
 - ATEX II2G Ex d IIC T6/T5/T4: XA091R/09/a3
 - ATEX 2D Ex tD A21 IP67 T110°C: XA092R/09/a3

www.addresses.endress.com

TRANSCAT[®]
Trust in every measure

Visit us at Transcat.com 

sales@transcat.com 1.800.828.1470

Endress + Hauser 
People for Process Automation