

Brief Operating Instructions Ecograph T, RSG35

Universal Data Manager

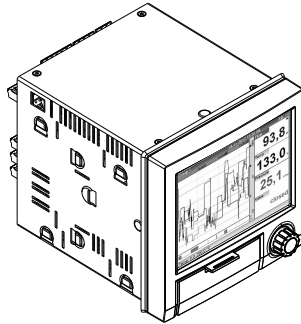

These Instructions are Brief Operating Instructions; they are not a substitute for the Operating Instructions pertaining to the device.

For detailed information, refer to the Operating Instructions and other documentation.

Available for all device versions via:

- Internet: www.endress.com/deviceviewer
- Smart phone/Tablet: Endress+Hauser Operations App

TRANSCAT[®]
Trust in every measure

Visit us at Transcat.com

sales@transcat.com 1.800.828.1470

Endress+Hauser 
People for Process Automation

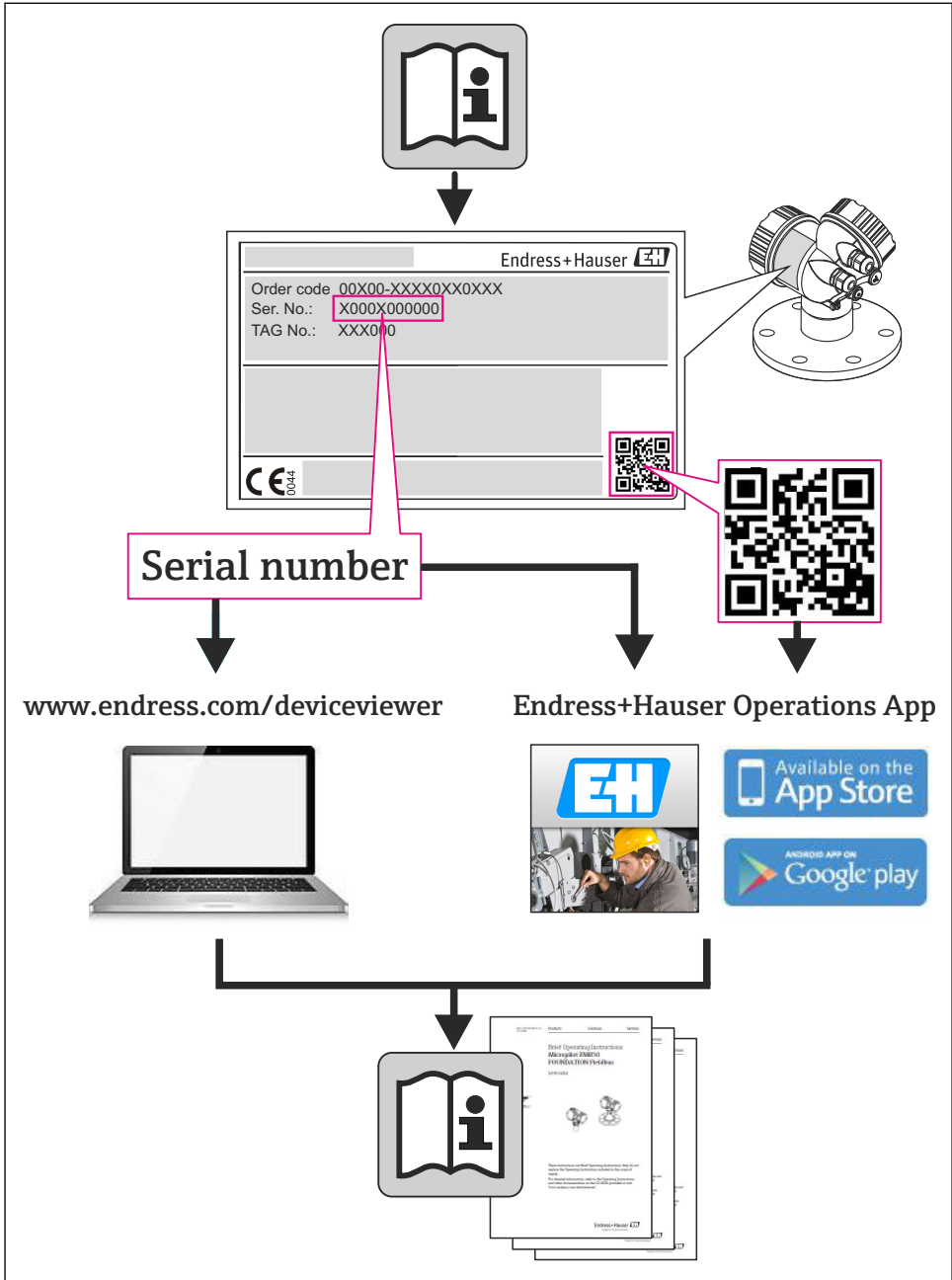

Table of contents

1	Document information	4
1.1	Document function	4
1.2	Symbols used	4
1.3	Terminology	5
2	Basic safety instructions	5
2.1	Requirements concerning the staff	6
2.2	Designated use	6
2.3	Workplace safety	6
2.4	Operational safety	6
2.5	Product safety	7
2.6	Safety information for table version (option)	7
2.7	IT security	7
3	Product description	7
3.1	Product design	7
4	Incoming acceptance and product identification	8
4.1	Incoming acceptance	8
4.2	Product identification	8
4.3	Storage and transport	9
5	Installation	9
5.1	Mounting requirements	9
5.2	Mounting the measuring device	10
5.3	Post-mounting check	12
6	Electrical connection	12
6.1	Connection conditions	12
6.2	Connection instructions	13
6.3	Connecting the measuring device	13
6.4	Post-connection check	21
7	Operation options	21
7.1	Overview of operation options	21
7.2	Measured value display and operating elements	22
7.3	Access to the operating menu via the local display	26
7.4	Device access via operating tools	26
8	System integration	26
8.1	Integrating the measuring device in the system	26
9	Commissioning	28
9.1	Function check	28
9.2	Switching on the measuring device	28
9.3	Setting the operating language	28
9.4	Configuring the measuring device (Setup menu)	28
9.5	Advanced settings (Expert menu)	31
9.6	Protecting settings from unauthorized access	32

1 Document information

1.1 Document function





These instructions contain all the essential information from incoming acceptance to initial commissioning.

Integrated Operating Instructions





The unit's simple control system enables you to perform commissioning for many applications without the need for hardcopy operating instructions. At the push of a button, the device displays operating instructions directly on the screen. These instructions are nevertheless delivered with the unit - they supplement the Operating Instructions in the unit. Anything that is not described directly at the device using plain text or selection lists is explained here.





1.2 Symbols used

1.2.1 Safety symbols





Symbol	Meaning
	DANGER! This symbol alerts you to a dangerous situation. Failure to avoid this situation will result in serious or fatal injury.
	WARNING! This symbol alerts you to a dangerous situation. Failure to avoid this situation can result in serious or fatal injury.
	CAUTION! This symbol alerts you to a dangerous situation. Failure to avoid this situation can result in minor or medium injury.
	NOTE! This symbol contains information on procedures and other facts which do not result in personal injury.

1.2.2 Symbols for certain types of information

Symbol	Meaning
	Permitted Indicates procedures, processes or actions that are permitted.
	Preferred Indicates procedures, processes or actions that are preferred.
	Forbidden Indicates procedures, processes or actions that are forbidden.
	Tip Indicates additional information.
	Reference to documentation Refers to the corresponding device documentation.

Symbol	Meaning
	Reference to page Refers to the corresponding page number.
	Reference to graphic Refers to the corresponding graphic number and page number.
	Series of steps
	Result of a sequence of actions
	Visual inspection

1.2.3 Symbols in graphics

Symbol	Meaning
1, 2, 3,...	Item numbers
	Series of steps
A, B, C, ...	Views
A-A, B-B, C-C, ...	Sections
 A0013441	Flow direction
 A0011187	Hazardous area Indicates a hazardous area.
 A0011188	Safe area (non-hazardous area) Indicates a non-hazardous area.

1.3 Terminology

To improve clarity, abbreviations or synonyms are used in these instructions for the following terms:

- Endress+Hauser:
Term used in these instructions: "Manufacturer" or "Supplier"
- Ecograph T RSG35:
Term used in these instructions: "Device" or "Measuring device"

2 Basic safety instructions

Reliable and safe operation of the device is guaranteed only if the user reads these Operating Instructions and complies with the safety instructions they contain.

2.1 Requirements concerning the staff

The staff must fulfill the following requirements for their tasks:

- ▶ Trained staff: Must have a qualification which corresponds to their function and tasks.
- ▶ Authorized by the plant operator.
- ▶ Familiar with the national regulations.
- ▶ Before starting their work: Must have read and understood all instructions in the operating manual and supplementary documentation as well as the certificate (depending on the application).
- ▶ Must comply with all instructions and the regulatory framework.

2.2 Designated use

This device is designed for the electronic acquisition, display, recording, analysis, remote transmission and archiving of analog and digital input signals in non-hazardous areas.

- The manufacturer accepts no liability for damages resulting from incorrect use or use other than that designated. It is not permitted to convert or modify the device in any way.
- The device is designed for installation in a panel and must only be operated in an installed state.

2.3 Workplace safety

For work on and with the device:

- ▶ Wear the required personal protective equipment according to federal/national regulations.

2.4 Operational safety

Risk of injury.

- ▶ Operate the device in proper technical condition and fail-safe condition only.
- ▶ The operator is responsible for interference-free operation of the device.

Conversions to the device

Unauthorized modifications to the device are not permitted and can lead to unforeseeable dangers.

- ▶ If, despite this, modifications are required, consult with the manufacturer.

Repair

To ensure continued operational safety and reliability,

- ▶ Carry out repairs on the device only if they are expressly permitted.
- ▶ Observe federal/national regulations pertaining to repair of an electrical device.
- ▶ Use original spare parts and accessories from the manufacturer only.

Hazardous area

To eliminate a danger for persons or for the facility when the device is used in the hazardous area (e.g. explosion protection, pressure vessel safety):

- ▶ Based on the nameplate, check whether the ordered device is permitted for the intended use in the hazardous area.

- ▶ Observe the specifications in the separate supplementary documentation that is an integral part of these Instructions.

2.5 Product safety

This measuring device is designed in accordance with good engineering practice to meet state-of-the-art safety requirements, has been tested, and left the factory in a condition in which it is safe to operate.

It meets general safety standards and legal requirements. It also complies with the EC directives listed in the device-specific EC Declaration of Conformity. The manufacturer confirms this by affixing the CE mark to the device.

2.6 Safety information for table version (option)

- The mains plug should only be inserted into a socket with a ground contact.
- The protective effect may not be suspended by an extension cable without a protective ground.
- Relay outputs: $U (\text{max}) = 30 \text{ V rms (AC)} / 60 \text{ V (DC)}$

2.7 IT security

We only provide a warranty if the device is installed and used as described in the Operating Instructions. The device is equipped with security mechanisms to protect it against any inadvertent changes to the device settings.

IT security measures in line with operators' security standards and designed to provide additional protection for the device and device data transfer must be implemented by the operators themselves.

3 Product description

3.1 Product design

This device is best suited for the electronic acquisition, display, recording, analysis, remote transmission and archiving of analog and digital input signals.

The device is intended for installation in a panel or cabinet. There is also the option of operating it in a table-mounted or field-mounted housing.

4 Incoming acceptance and product identification

4.1 Incoming acceptance

On receipt of the goods, check the following points:

- Is the packaging or the content damaged?
- Is the delivery complete? Compare the scope of delivery against the information on your order form.

4.1.1 Scope of delivery

The scope of delivery of the device comprises:

- Device (with terminals, as per your order)
- 2 fastening clips
- USB cable
- Optional: Industrial grade SD card (card is located in the device)
- Field Data Manager (FDM) analysis software on CD-ROM
- FieldCare configuration software on DVD
- Delivery note
- Multilingual Brief Operating Instructions as hard copy



Anything missing? Then please inform your supplier.

4.2 Product identification

4.2.1 Nameplate

Compare the nameplate with the following diagram:

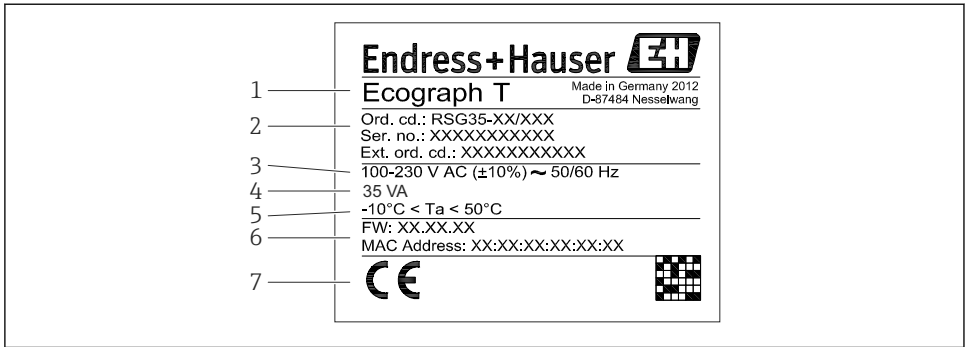

A0019299

1 Device nameplate (example)

- 1 Device designation
- 2 Order code, serial number, extended order code
- 3 Power supply, mains frequency
- 4 Power consumption
- 5 Temperature range
- 6 Software version; MAC address
- 7 Device approvals

4.3 Storage and transport

Compliance with the permitted environmental and storage conditions is mandatory. Precise specifications are provided in the "Technical data" section of the Operating Instructions.

Please note the following:

- Pack the device so that is protected against impact for storage and transport. The original packaging provides optimum protection.
- The permitted storage temperature is -20 to $+60$ °C (-4 to $+140$ °F).

5 Installation

5.1 Mounting requirements

NOTICE

Overheating due to buildup of heat in the device

- ▶ To avoid heat buildup, please always ensure that the device is sufficiently cooled.

The device is designed for use in a panel in non-hazardous areas.

- Ambient temperature range -10 to $+50$ °C (14 to 122 °F)
- Climate class as per IEC 60654-1: Class B2
- Degree of protection: IP65, NEMA 4 at front / IP20 housing at rear

5.1.1 Installation dimensions

Please observe the installation depth of approx. 158 mm (6.22 in) for the device incl. terminals and fastening clips.

- Panel cutout: 138 to 139 mm (5.43 to 5.47 in) x 138 to 139 mm (5.43 to 5.47 in)
- Panel strength: 2 to 40 mm (0.08 to 1.58 in)
- Angle of vision: from the midpoint axis of the display, 75° to the left and right, 65° above and below.
- A minimum distance of 15 mm (0.59 in) mm (inch) between the devices must be observed if aligning the devices in the Y-direction (vertically above one another). A minimum distance of 10 mm (0.39 in) mm (inch) between the devices must be observed if aligning the devices in the X-direction (horizontally beside one another).
- Securing to DIN 43 834

5.2 Mounting the measuring device

 Mounting tool: For installation in the panel, all you need is a screwdriver.

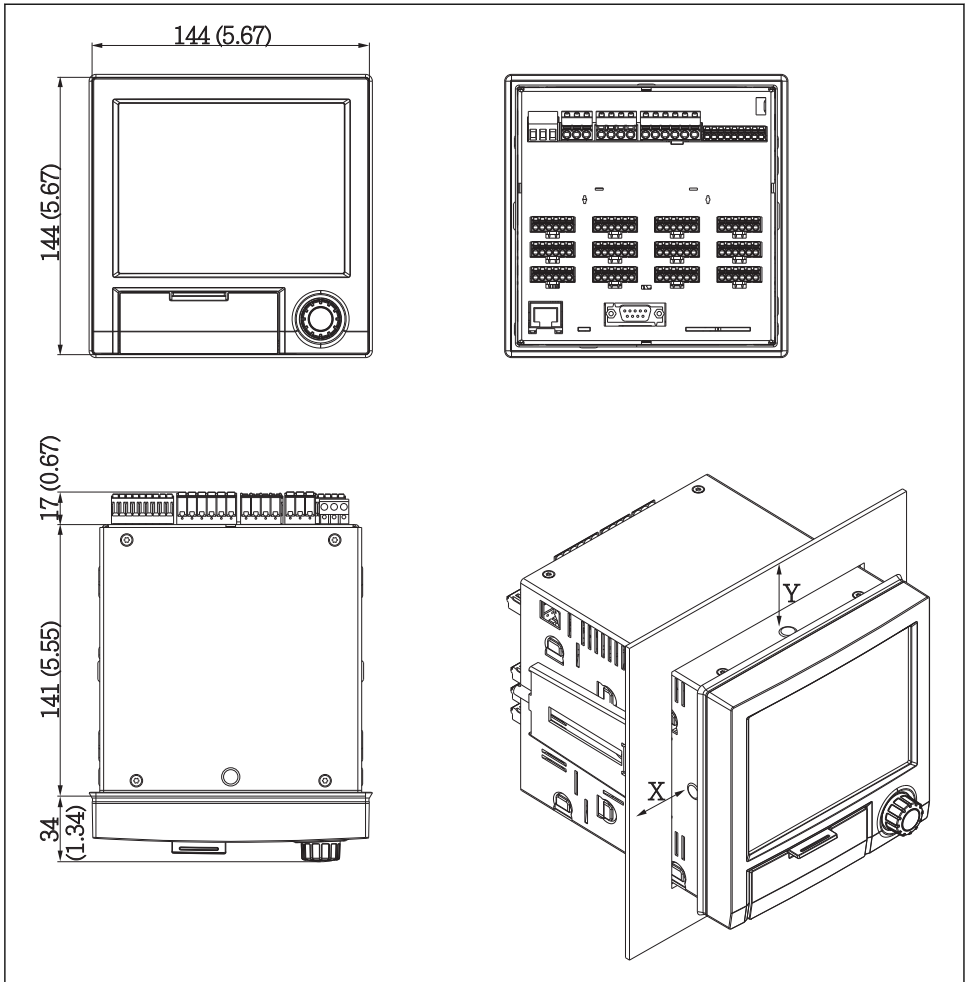

A0019301

2 Panel mounting and dimensions in mm (Inch)

1. Push the device through the panel cutout from the front. To avoid heat buildup, maintain a distance of > 15 mm (> 0.59 in) from walls and other devices.
2. Hold the device level and hang the fastening clips in the openings (1 x left, 1 x right).
3. Evenly tighten the screws on the fastening clip using a screwdriver to guarantee a secure seal to the control panel (torque 100 Ncm).

5.3 Post-mounting check

- Is the sealing ring undamaged?
- Does the seal run all around the housing collar?
- Are the threaded rods properly tightened?
- Is the device fixed firmly in the center of the control panel cutout?

6 Electrical connection

6.1 Connection conditions

WARNING

Danger! Electric voltage!

- ▶ The entire connection of the device must take place while the device is de-energized.
- ▶ The mixed connection of safety extra-low voltage and dangerous contact voltage to the relay is **not** permitted.

Danger if protective ground is disconnected

- ▶ The ground connection must be made before all other connections.

NOTICE

Cable heat load

- ▶ Use suitable cables for temperatures of 5 °C (9 °F) above ambient temperature.

Incorrect supply voltage can damage the device or cause malfunctions

- ▶ Before commissioning the device, make sure that the supply voltage matches the voltage specifications on the nameplate.

Check emergency shutdown for device

- ▶ Provide suitable switch or circuit breaker in building installation. This switch must be provided close to the device (within easy reach) and marked as a circuit breaker.

Protect the device from overload

- ▶ Provide overload protection (nominal current = 10 A) for power cable.

Incorrect wiring may result in the device being destroyed

- ▶ Note terminal designation on the rear of the device.

Energy-rich transients in the case of long signal lines

- ▶ Install suitable overvoltage protection (e.g. E+H HAW562) upstream.

6.2 Connection instructions

6.2.1 Cable specification

Cable specification, spring terminals

All connections to the rear of the unit are designed as screw or spring terminal blocks with reverse polarity protection. This makes the connection very quick and easy. The spring terminals are unlocked with a slotted screwdriver (size 0).

Please note the following when connecting:

- Wire cross-section, auxiliary voltage output, digital I/O and analog I/O: max. 1.5 mm² (14 AWG) (spring terminals)
- Wire cross-section, power supply: max. 2.5 mm² (13 AWG) (screw terminals)
- Wire cross-section, relays: max. 2.5 mm² (13 AWG) (spring terminals)
- Stripping length: 10 mm (0.39 in)



No ferrules have to be used when connecting flexible wires to spring terminals.

Cable type



Use shielded signal lines for interfaces!

6.3 Connecting the measuring device

6.3.1 Supply voltage

Power unit type	Terminal		
	<small>A0019103</small>		
100-230 VAC	L+	N-	PE
	Phase L	Zero conductor N	Ground
24 V AC/DC	L+	N-	PE
	Phase L or +	Zero conductor N or -	Ground

6.3.2 Relay

Type	Terminal (max. 250 V, 3 A)				
A0019103					
Alarm relay 1	R11	R12	R13		
	Changeover contact	Normally closed contact (NC) ¹⁾	Normally open contact (NO) ²⁾		
Relay 2 to 6				Rx1	Rx2
				Switching contact	Normally open contact (NO ²⁾)

- 1) NC = normally closed (breaker)
- 2) NO = normally open (maker)

6.3.3 Digital inputs; auxiliary voltage output

Type	Terminal			
A0019103				
Digital input 1 to 6	D11 to D61	GND1		
	Digital input 1 to 6 (+)	Mass (-) for digital inputs 1 to 6		
Auxiliary voltage output, not stabilized, max. 250 mA			24V Out -	24V Out +
			- Mass	+ 24V (±15%)

6.3.4 Analog inputs

The first digit (x) of the two-digit terminal number corresponds to the associated channel:

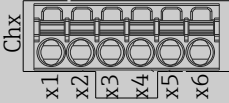
Type	Terminal					
						
	x1	x2	x3	x4	x5	x6
Current/pulse/frequency input ¹⁾					(+)	(-)
Voltage > 1V		(+)				(-)
Voltage ≤ 1V				(+)		(-)
Resistance thermometer RTD (2-wire)	(A)					(B)
Resistance thermometer RTD (3-wire)	(A)			b (sense)		(B)
Resistance thermometer RTD (4-wire)	(A)		a (sense)	b (sense)		(B)
Thermocouples TC				(+)		(-)

A0019303

1) If a universal input is used as a frequency or pulse input and the voltage is >2.5 V, a resistance must be used in series connection with the voltage source. Example: 1.2 kOhm series resistance at 24 V

6.3.5 Connection example: Auxiliary voltage output as transmitter power supply for 2-wire sensors

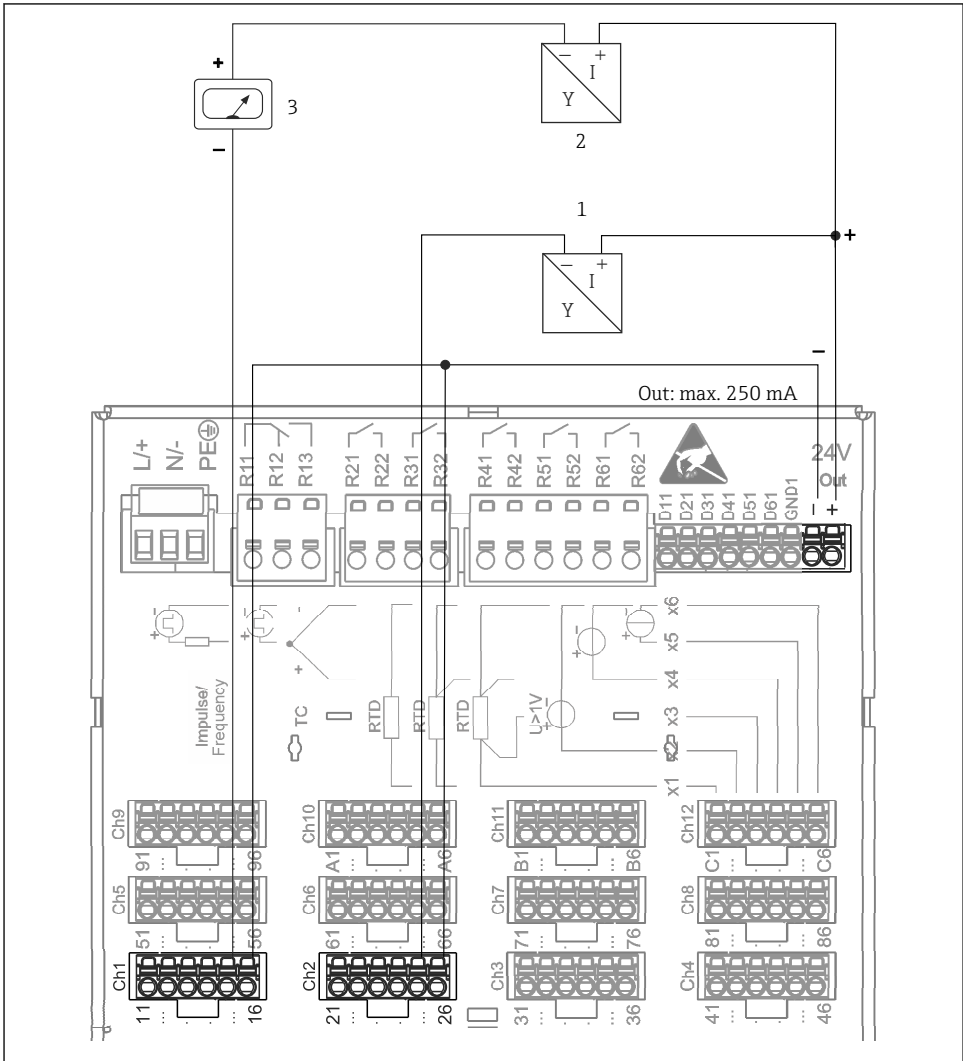

A0020259

3 Connecting auxiliary voltage output when using as a transmitter power supply for 2-wire sensors in the current measuring range (When connecting channel CH3-12, see pin assignment CH1-2.)

- 1 Sensor 1 (e.g. Cerabar from Endress+Hauser)
- 2 Sensor 2
- 3 External indicator (optional) (e.g. RIA16 from Endress+Hauser)

6.3.6 Connection example: Auxiliary voltage output as transmitter power supply for 4-wire sensors

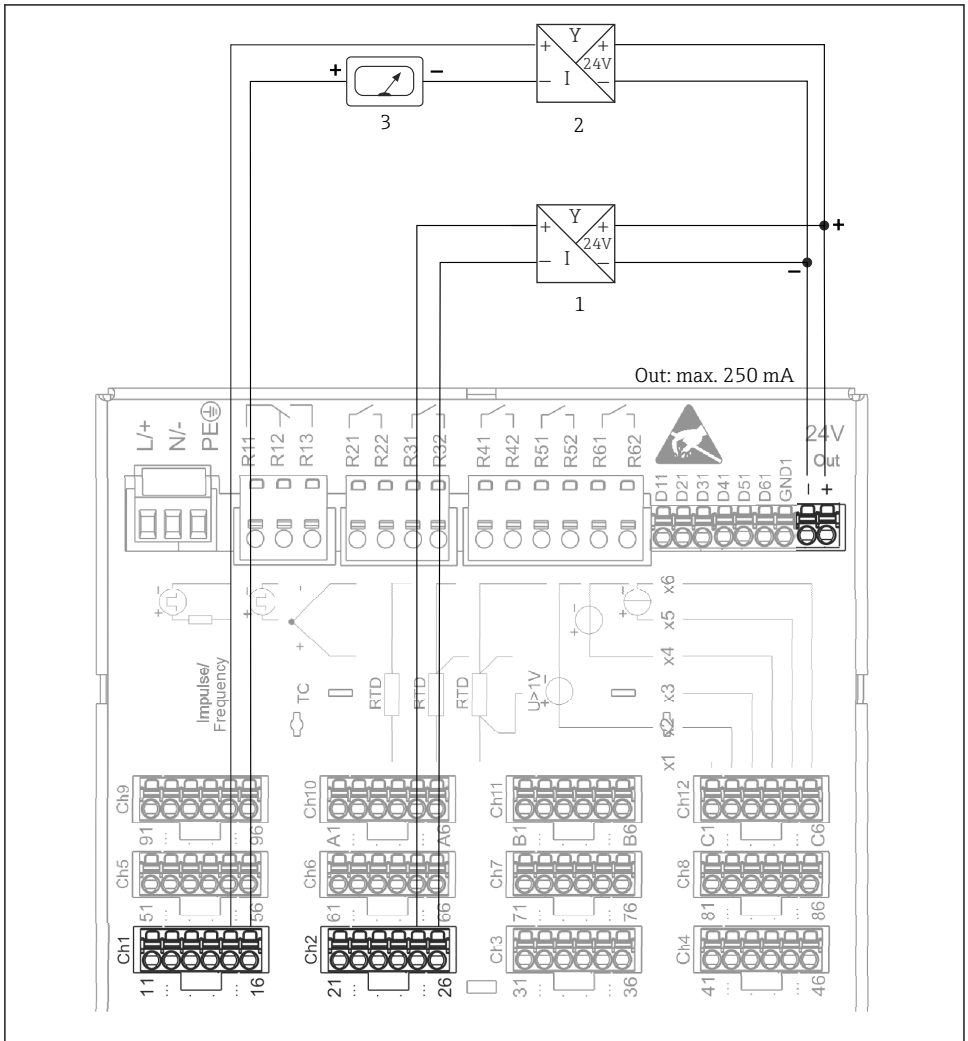

A0020260

4 Connecting auxiliary voltage output when using as a transmitter power supply for 4-wire sensors in the current measuring range. (When connecting channel CH3-12, see pin assignment CH1-2.)

- 1 Sensor 1 (e.g. temperature switch TTR31 from Endress+Hauser)
- 2 Sensor 2
- 3 External indicator (optional) (e.g. RIA16 from Endress+Hauser)

6.3.7 Option: RS232/RS485 interface (rear of device)

i Use shielded signal lines for serial interfaces!

A combined RS232/RS485 connection is available on a shielded SUB D9 socket at the rear of the device. This can be used for data or program transfer and to connect a modem. For communication via modem, we recommend an industrial modem with a watchdog function.

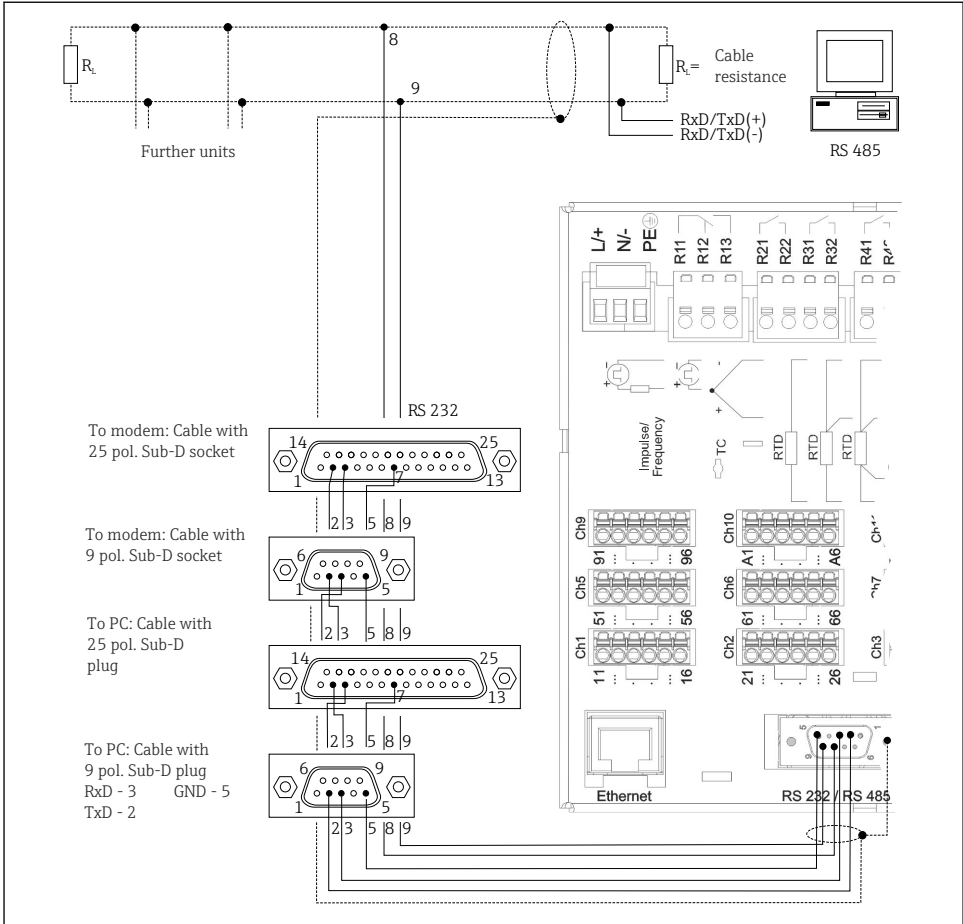

A0019305-EN

Type	Pin of the SUB-D9 socket								
	1	2	3	4	5	6	7	8	9
RS232 assignment		TxD (data output)	RxD (data input)		GND				

Type	Pin of the SUB-D9 socket							
RS485 assignment				GND			RxD/TxD -	RxD/TxD +
Unoccupied connections should be left empty. Maximum cable length: RS232: 2 m (6.6 ft) RS485: 1000 m (3280 ft)								



Only one interface can be used at any one time (RS232 or RS485).

6.3.8 Ethernet connection (rear of device)

The Ethernet interface can be used to integrate the device via a hub or switch into a PC network (TCP/ IP Ethernet). A standard patch cable (e.g. CAT5E) can be used for the connection. Using DHCP, the device can be fully integrated into an existing network without the need for additional configuration. The device can be accessed from every PC in the network.

- Standard: 10/100 Base T/TX (IEEE 802.3)
- Socket: RJ-45
- Max. cable length: 100 m
- Galvanic isolation; testing voltage: 500 V

Meaning of the LEDs

Beneath the Ethernet connection (see rear of device) there are two light emitting diodes which indicate the status of the Ethernet interface.

- Yellow LED: link signal; is lit when the device is connected to a network. If this LED is not illuminated then communication is impossible.
- Green LED: Tx/Rx; flashes irregularly if the device is transmitting or receiving data.

6.3.9 Option: Ethernet Modbus TCP slave

The Modbus TCP interface is used to connect to higher-ranking SCADA systems (Modbus master) to transmit all measured values and process values. Up to 12 analog inputs and 6 digital inputs can be transmitted via Modbus and stored in the device. Form a physical point of view, the Modbus TCP interface is identical to the Ethernet interface.

6.3.10 Option: Modbus RTU slave

The Modbus RTU (RS485) interface is galvanically isolated (testing voltage: 500 V) and is used to connect to higher-ranking systems to transmit all measured values and process values. Up to 12 analog inputs and 6 digital inputs can be transmitted via Modbus and stored in the device. Connection is via the combined RS232/RS485 interface.



Modbus TCP and Modbus RTU cannot be used at the same time.

6.3.11 Connections at front of device

USB connection type A (host)

A USB 2.0 connection is available on a shielded USB A socket at the front of the device. A USB stick, for example, can be connected to this interface as a storage medium. An external keyboard or USB hub may also be connected.

USB connection type B (function)

A USB 2.0 connection is available on a shielded USB B socket at the front of the device. This can be used to connect the device for communication with a laptop, for example.



USB-2.0 is compatible with USB-1.1 or USB-3.0, i.e. communication is possible.

Information on USB devices

The USB devices are detected by the "plug-and-play" function. If several devices of the same type are connected, only the USB device that was connected first is available. Settings for the USB devices are made in the setup. A maximum of 8 external USB devices (incl. USB hub) can be connected if they do not exceed the maximum load of 500 mA. If overloaded, the corresponding USB devices are automatically disabled.

Requirements with regard to an external USB hub

If USB devices are deactivated due to the 500 mA device limit, such devices can be connected by means of a USB hub. Only active USB hubs (i.e. hubs with their own power supply) can be connected to the unit. Hubs with an "overcurrent protection" are recommended. A maximum of 1 hub can be connected to the unit.

Requirements with regard to the USB stick

There is no guarantee that all manufacturers' USB sticks will function faultlessly. That is why an industrial grade SD card is recommended to ensure the reliable recording of data.



The USB stick must be formatted to FAT or FAT32. NTFS format is not readable. The system supports only USB sticks with max. 32 GB.

Requirements with regard to an external USB keyboard

The system only supports keyboards which can be addressed using generic drivers (HID keyboard - Human Interface Device). Special keys are not supported (e.g. Windows keys). Users can only enter characters that are available in the entry character set of the unit. All unsupported characters are rejected. It is not possible to connect a wireless keyboard. The following keyboard layouts are supported: DE, CH, FR, USA, USA International, UK, IT. See setting under "Setup -> Advanced setup -> System -> Keyboard layout".

Requirements for the SD card

Industrial grade SD-HC cards with max. 32 GB are supported.



Use only the industrial grade SD cards described in the "Accessories" section of the Operating Instructions. These have been tested by the manufacturer and guaranteed to function faultlessly in the device.



The SD card must be formatted to FAT or FAT32. NTFS format is not readable.

6.4 Post-connection check

Device condition and specifications	Notes
Are cables or the device damaged?	Visual inspection
Electrical connection	Notes
Does the supply voltage match the specifications on the nameplate?	-
Are all terminals firmly engaged in their correct slot?	-
Are the mounted cables strain-relieved?	-
Are the power supply and signal cables correctly connected?	See connection diagram and rear of device.

7 Operation options

7.1 Overview of operation options

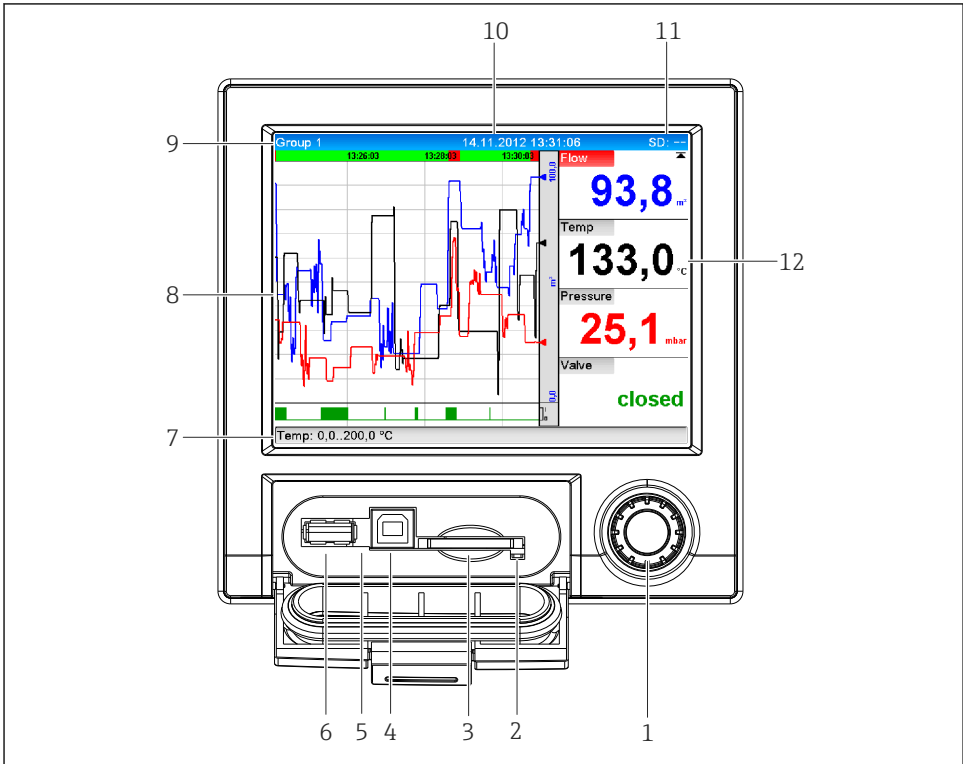

The device can be operated onsite or via interfaces (serial, USB, Ethernet) and operating tools (web server; FieldCare configuration software).

7.2 Measured value display and operating elements







A0020602-EN

5 Front of device with open flap

Item No.	Operating function (display mode = display of measured values) (Setup mode = operating in the Setup menu)
1	<p>"Navigator": Jog/shuttle dial for operating with additional press function.</p> <p>In Display mode: turn the dial to switch between the various signal groups. Press the dial to display the main menu.</p> <p>In Setup mode or in a selection menu: turn the dial anticlockwise to move the bar or the cursor upwards or counterclockwise, changes the parameter. Turning clockwise moves the bar or cursor down or clockwise, changes parameter.</p> <p>Press briefly (<2 sec.) = Select highlighted function, parameter change starts (ENTER key).</p> <p> Access online help: Press and hold Navigator (>3 sec.) to show information on the selected function. To quit the menu immediately, press and hold "Back" (>3 sec.) in the Navigator. The device switches to Display mode.</p>
2	<p>LED at SD slot. Orange LED lit when the device writes to the SD card or reads it. Do not remove the SD card if the LED is lit! Risk of data loss!</p>
3	Slot for SD card
4	USB B socket "Function" e.g. to connect to PC or laptop
5	Green LED lit: Power supply present
6	USB A socket "Host" e.g. for USB memory stick or external keyboard
7	<p>In Display mode: alternating status display (e.g. set zoom range) of the analog or digital inputs in the appropriate color of the channel.</p> <p>In Setup mode: different information can be displayed here depending on the display type.</p>
8	<p>In Display mode: window for measured value display (e.g. curve display).</p> <p>In Setup mode: display of operating menu</p>
9	<p>In Display mode: current group name, type of evaluation</p> <p>In Setup mode: name of the current operating item (dialog title)</p>
10	<p>In Display mode: displays current date/time</p> <p>In Setup mode: --</p>
11	<p>In Display mode: alternating display indicating the percentage space on the SD card or USB stick that has already been used.</p> <p>Status symbols are also displayed in alternation with the memory information (see the following table).</p> <p>In Setup mode: the current "direct access" operating code is displayed</p>
12	<p>In Display mode: display of current measured values and the status in the event of an error/alarm condition. In the case of counters, the type of counter is displayed as a symbol (see the following table).</p> <p> If a measuring point has limit value status, the corresponding channel identifier is highlighted in red (quick detection of limit value violations). During a limit value violation and device operation, the acquisition of measured values continues uninterrupted.</p>

7.2.1 Display representation of symbols used in operation

Item No.	Function	Description
8,12	Symbols for counters:	
	$\Sigma 0 / \Sigma 1$	Interim analysis/ external analysis
	ΣD	Daily analysis
	ΣM	Monthly analysis
	ΣY	Annual analysis
	Σ	Totalizer
8, 12	Channel-related symbols:	
		Violation of lower limit value
		Violation of upper limit value or limit value on counter
		Violation of upper and lower limit values at the same time
	S	"Out of specification" e.g. input signal too high/low
	F	Error message "Failure detected" An operating error has occurred. The measured value is no longer valid (e.g. a channel not displayed in the current group is defective).
	M	"Maintenance required" Maintenance is required. The measured value is still valid.
	-----	Error, measured value not displayed. Possible causes: Sensor / input error, line break, invalid value, input signal too high/low
11	Symbol for status signals:	
		"Device locked" The setup is locked via a control input or access code. Enter the relevant access code or unlock the setup using the control input
	S	"Out of specification" The device is being operated outside its technical specifications (e.g. during warm-up or cleaning processes).
	C	"Function check" The device is in Service mode.
	M	"Maintenance required" Maintenance is required. The measured value is still valid.
	F	Error message "Failure detected" An operating error has occurred. The measured value is no longer valid (e.g. a channel not displayed in the current group is defective).

Item No.	Function	Description
		"External communication" The device is communicating externally (e.g. via Modbus).
	SIM	"Simulation" Simulation is active.

7.2.2 Symbols in operating menus



Symbol for setup



Symbol for expert setup



Symbol for diagnostics



Back

Use the "Back" function, which can be found at the bottom of each menu/submenu, to move up a level in the menu structure.



To quit the menu immediately, press and hold "Back" (>3 sec.) in the Navigator. The devices switches to Display mode.

7.2.3 Entering text and numbers (virtual keyboard)

A virtual keyboard is available for entering text and numbers. This is opened automatically if needed. Here, turn the navigator to select the corresponding character and press the navigator to accept it.

The following characters are available for entering free text:

0-9 a-z A-Z = + - * / \ ²³ ¼ ½ ¾ () [] < > { } I ? ! ` ` ^ % ° . , : _ µ & # \$ € @ \$ £ ¥ ~



Jump one position to the left.

If this symbol is selected, the cursor jumps one position to the left.



Jump one position to the right.

If this symbol is selected, the cursor jumps one position to the right.



Delete backwards.

If this symbol is selected, the character to the left of the cursor position is deleted.



Delete forwards.

If this symbol is selected, the character to the right of the cursor position is deleted.



Delete all.

If this symbol is selected, the entire entry is deleted.



Reject entry.

If this symbol is selected, the entry is rejected and you quit editing mode. The previously set text remains.



Accept entry.

If this symbol is selected, the entry is applied at the position specified by the user, and you quit editing mode.

7.2.4 Channel color assignment

Channel color assignment is performed in the main menu under "**Setup -> Advanced setup -> Application -> Signal groups -> Group x**". 8 predefined colors are available per group and can be assigned to the desired channels.

7.3 Access to the operating menu via the local display

Using the "Navigator" (jog/shuttle dial with additional press function), all settings can be made directly onsite at the device.

7.4 Device access via operating tools

Device configuration and measured value retrieval can also be done via interfaces. The following operating tools are available for this purpose:

Operating tool	Functions	Access via
Field Data Manager (FDM) analysis software, SQL database support (included in scope of delivery)	<ul style="list-style-type: none"> ▪ Export of saved data (measured values, analyses, event log) ▪ Visualization and processing of saved data (measured values, analyses, event log) ▪ Safe archiving of exported data in a SQL database 	RS232/RS485, USB, Ethernet
Web server (integrated into the device; access via browser)	<ul style="list-style-type: none"> ▪ Display of current and historical data and measured value curves via the web browser ▪ Easy configuration without additional installed software ▪ Remote access to device and diagnostic information 	Ethernet
OPC server (optional)	<p>The following momentary values can be provided:</p> <ul style="list-style-type: none"> ▪ Analog channels ▪ Digital channels ▪ Mathematics ▪ Totalizer 	RS232/RS485, USB, Ethernet
FieldCare Configuration software (included in scope of supply)	<ul style="list-style-type: none"> ▪ Device configuration ▪ Loading and saving device data (upload/download) ▪ Documentation of the measuring point 	USB, Ethernet



The configuration of device-specific parameters is described in detail in the Operating Instructions.

8 System integration

8.1 Integrating the measuring device in the system



Detailed information on system integration can be found in the Operating Instructions.

8.1.1 General notes

The device has (optional) fieldbus interfaces for exporting process values. Measured values and statuses can also be transmitted to the device via fieldbus. Note: Counters cannot be transferred.

Depending on the bus system, alarms or faults occurring during data transmission are displayed (e.g. status byte).

The process values are transferred in the same devices that are used for display at the device.

9 Commissioning

9.1 Function check

Make sure that all post-connection checks have been carried out before putting your device into operation:

- Checklist for "post-installation check", (→  12).
- Checklist for "post-connection check" (→  21).

9.2 Switching on the measuring device

Once the operating voltage is applied, the display lights up and the device is ready for operation.

If you are commissioning the device for the first time, program the setup as described in the following sections of the Operating Instructions.

If you are commissioning a device that is already configured or preset, the device starts measuring immediately as defined in the settings. The values of the channels currently activated are shown on the display.

 Remove the protective film from the display as this would otherwise affect the readability of the display.

9.3 Setting the operating language

The operating language can be set in the main menu. You can access the main menu by pressing the Navigator during operation. "Sprache/Language" appears in the display. Press the Navigator again to open the language selection. Turn the Navigator to select the desired language, and press the Navigator to apply the language.

 Use the  "Back" function, which can be found at the bottom of each menu/submenu, to move up a level in the menu structure.

To quit the menu immediately, press and hold "Back" (>3 sec.) in the Navigator. You will return immediately to the measured value display.

9.4 Configuring the measuring device (Setup menu)

Access to the setup is released when the device leaves the factory and can be locked in various ways e.g. by entering a 4-digit access code. When locked, basic settings can be checked but not changed. You can also use a PC to commission or configure your device.

Device configuration options

- Setup directly at the device
- Setup via SD card or USB stick by transferring the parameters stored on it
- Setup via web server using Ethernet
- Setup via FieldCare configuration software using USB interface or Ethernet

9.4.1 Setup directly at the device

You can access the main menu by pressing the Navigator during operation. Turn the Navigator to navigate through the available menus. When the desired menu is displayed, press the Navigator to open the menu.

In the **"Setup"** menu and in the **"Advanced setup"** submenu, you will find the **most important** settings for the device:

Parameter		Possible settings	Description
Change date/time		UTC time zone dd.mm.yyyy hh:mm:ss	You can change the date and time here.
Advanced setup			Advanced settings for the device e.g. system settings, inputs, outputs, communication, application etc.
	System		Basic settings that are needed to operate the device, (e.g. date/ time, security, memory management, messages, etc.)
	Inputs		Settings for analog and digital inputs.
	Outputs		Settings only required if outputs (e.g. relays or analog outputs) are to be used.
	Communication		Settings required if the USB, RS232/RS485 or Ethernet interface of the device is to be used (PC operation, serial data export, modem operation, etc.).  The different interfaces (USB, RS232/RS485, Ethernet) can be operated in parallel. However, simultaneous use of the RS232 and RS485 interface is not possible.
	Application		Define different application-specific settings (e.g. group settings, limit values etc.).



A detailed overview of all operating parameters can be found in the appendix at the end of the Operating Instructions.

9.4.2 Setup via SD card or USB stick

Save the device settings (setup data) on an SD card or USB stick. This setup file can then be imported into other devices.

Save setup: The function used to save the setup files can be found in the main menu under **"Operation -> SD card (or USB stick) -> Save setup"**.

CAUTION

If the SD card or USB stick are removed directly:

Risk of data loss on SD card or USB stick

- ▶ To remove the SD card or the USB stick, always select **"Operation -> SD card (or USB stick) -> Remove safely"** in the main menu!

Import new setup directly at the device: The function used to load the setup data can be found in the main menu under "**Operation -> SD card (or USB stick) -> Load setup**". Repeat these steps to configure additional units with this setup.

CAUTION

If the SD card is not removed, saving of the measurement data will commence after approx. 5 minutes.

Measured values may be saved unintentionally on the SD card. However, the setup data are still retained in the memory.

- ▶ Replace SD card on time!

9.4.3 Setup via web server

To configure the device via the web server, connect the device via Ethernet to your PC.

Please observe the information and communication settings for Ethernet and the web server under (→  26)



To configure the device via a web server, you must have Administrator or Service access. Prior to accessing the web server, create an ID and password in the main menu under "**Setup -> Advanced setup -> Communication -> Ethernet -> Configuration Web server -> Authentication**".

ID default value: admin; Password: admin

Note: The password should be changed during commissioning!

Establishing a connecting and setup

Procedure for setting up a connection:

1. Connect the device to the PC via Ethernet
2. Start the browser at the PC; open the web server for the device by entering the IP address: `http://<ip-adresse>` Note: Leading zeros in IP addresses must not be entered (e.g. enter 192.168.1.11 instead of 192.168.001.011).
3. Enter ID and password, and confirm each by clicking "OK"
4. The web server shows the momentary value display of the device. Click "Menu" in the web server taskbar.
5. Starting configuration

Procedure to establish a direct connection via Ethernet (point to point connection):

1. Configure the PC (depends on operating system): e.g. IP address: 192.168.1.1; subnet mask: 255.255.255.0; gateway: 192.168.1.1
2. Disable DHCP on the device
3. Make communication settings on the device: e.g. IP address: 192.168.1.2; subnet mask: 255.255.255.0; gateway: 192.168.1.1



A crossover cable is not required.

Continue with device configuration in accordance with the Operating Instructions for the device. The complete Setup menu i.e. all of the parameters listed in the Operating Instructions, can also be found on the web server. Once configuration is complete, log out of the web server.

NOTICE

Undefined switching of outputs and relays

- ▶ During configuration using a web server, the device may assume undefined statuses! This may result in the undefined switching of outputs and relays.

9.4.4 Setup via FieldCare configuration software (included in scope of supply)

To configure the device using the configuration software, connect the device to your PC via USB or Ethernet.

Establishing a connection and setup



For details, see the Operating Instructions on the configuration software DVD provided

Continue with device configuration in accordance with the Operating Instructions for the device. The complete Setup menu, i.e. all the parameters listed in the Operating Instructions, can also be found in the configuration software.

NOTICE

Undefined switching of outputs and relays

- ▶ During configuration using the configuration software, the device may assume undefined statuses! This may result in the undefined switching of outputs and relays.

9.5 Advanced settings (Expert menu)

You can access the main menu by pressing the Navigator during operation. Turn the Navigator to navigate to the "**Expert**" menu. Press the Navigator to open the menu.



The Expert menu is protected by the code "**0000**". If an access code is set up under "**Setup -> Advanced setup -> System -> Security -> Protected by -> Access code**", this must be entered here.

You will find **all** settings for the device in the "**Expert**" menu:

Parameter	Possible settings	Description
Direct access	000000-000	Direct access to parameters (fast access)
System		Basic settings that are needed to operate the unit, (e.g. date/ time, security, memory management, messages, etc.)
Inputs		Configuration of analog and digital inputs.
Outputs		Settings only required if outputs (e.g. relays or analog outputs) are to be used.

Parameter	Possible settings	Description
Communication		Settings required if the USB, RS232/RS485 or Ethernet interface of the device is to be used (PC operation, serial data export, modem operation, etc.).  The different interfaces (USB, RS232/RS485, Ethernet) can be operated in parallel. However, simultaneous use of the RS232 and RS485 interface is not possible.
Application		Define different application-specific settings (e.g. group settings, limit values etc.).
Diagnostics		Device information and service functions for a swift device check.

 A detailed overview of all operating parameters can be found in the appendix at the end of the Operating Instructions.

9.6 Protecting settings from unauthorized access

To protect the setup from unauthorized access, the setup must be protected by means of an access code or control input once configuration is complete. In order to change any parameter, the correct code must first be entered or the device must be unlocked using the control input.

Setup lock via control input: The settings for the control input can be found in the main menu under "**Setup -> Advanced setup -> Inputs -> Digital inputs -> Digital input X -> Function: Control input; Action: Lock setup**".

 It is preferable to lock the setup using a control input.

Setting up an access code: The settings for the access code can be found in the main menu under "**Setup -> Advanced setup -> System -> Security -> Protected by -> Access code**". Factory setting: "open access", i.e. can be changed at any time.

 Make a note of the code and store in a safe place.

www.addresses.endress.com



Visit us at Transcat.com 

sales@transcat.com 1.800.828.1470

Endress+Hauser 
People for Process Automation