

Model 6248 Minigrabber Test clip To Sheathed Banana Jack

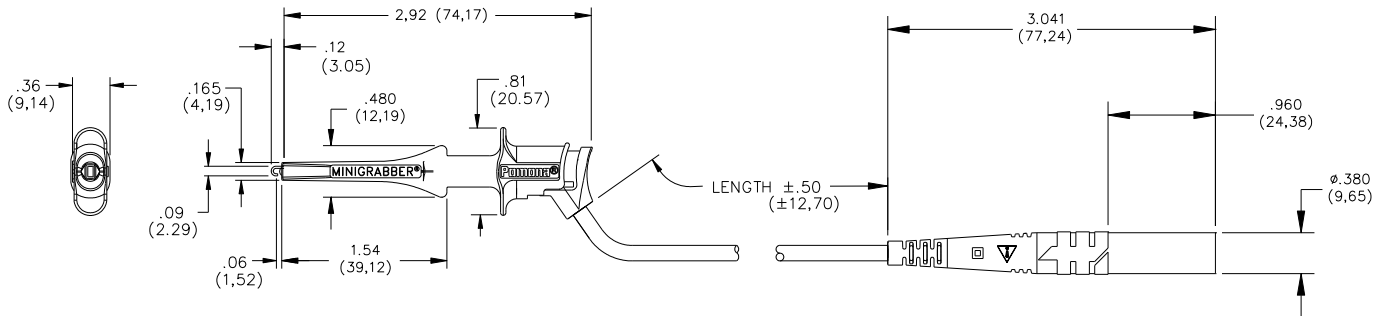

FEATURES:

- Newly designed Minigrabber® Test Clip Patch Cord complies with IEC 1010-2-31, which is the latest international safety standard for test accessories.
- Grabber width is a slim .36" (9,14 mm) for easier access to test terminals.
- Grabber hook is gold plated beryllium copper to ensure signal integrity & attaches onto component leads up to .060" (1,5 mm) O.D.
- Grabber patch cord can connect directly to Pomona's sheathed type flexible tests leads for added patch cord length.
- For added safety, the grabber and banana plug body insulation material is fire retardant Nylon 6, UL94V-0 rated.
- Banana jack is molded directly to the cable for a long lasting connection.
- High strand count silicone insulated wire offers excellent flexibility and high temperature resistance.

MATERIALS:

Grabber: Body: Nylon 6 – Fire Retardant – UL94 V-O Rated, Color per part number

Hook: Beryllium Copper, Gold Plated, Compression Spring: Music Wire

Wire: 18 AWG, 65 x 36 Tinned Copper, Insulation – Silicone, .144" (3,66 mm) O.D., Color per Part Number

Banana Jack: Body - Brass, Nickel Plated

Insulation - Nylon 6, Fire Retardant UL94 V-0 Rated, Color per part number

RATINGS:

IEC 1010 2-031, Category II, P2 Compliant

Voltage: 300 VRMS/DC Max.

Current: 5 Amperes Max.

ORDERING INFORMATION: Model 6248-XX-*

XX = Lead Length in Inches, Standard Length: 12" (30,48 cm)

* = Color Code, -0 Black and -2 Red

Additional lengths can be quoted upon request.

All dimensions are in inches. Tolerances (except noted): .xx = ±.02" (.51 mm), .xxx = ±.005" (.127 mm).

All specifications are to the latest revisions. Specifications are subject to change without notice.

Registered trademarks are the property of their respective companies.