

Pomona®

**Model 5906A
Modular Test Probe Handle
With Banana Plug Tip**

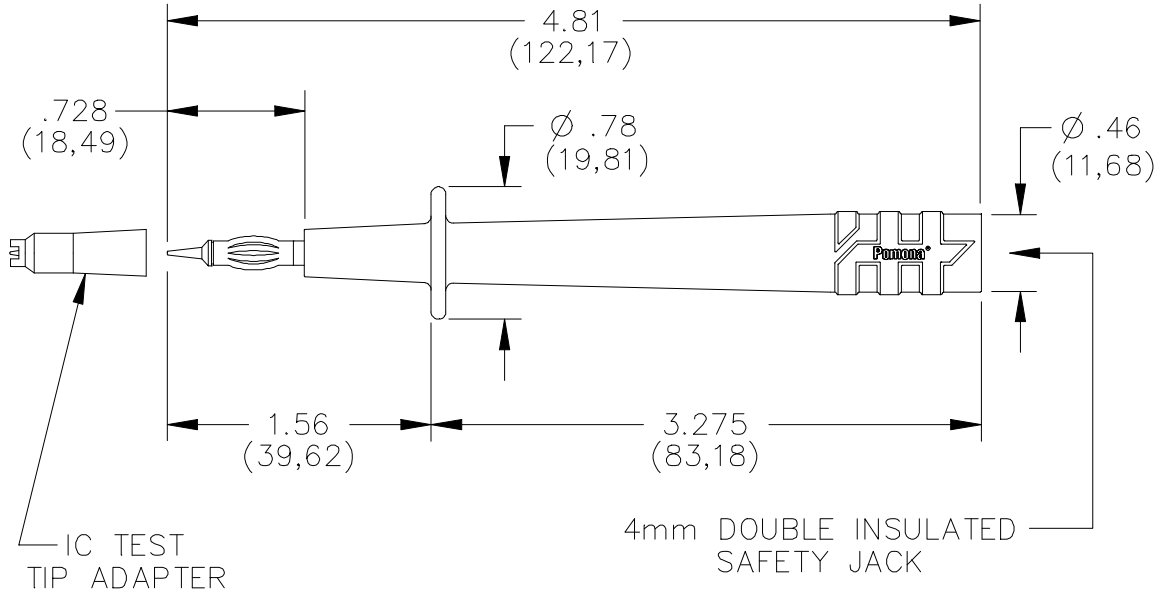

FEATURES:

- Model 5906A has been redesigned to meet IEC 1010-2-31, which is the latest international safety standard for test accessories.
- Probe safety jack mates to Pomona’s 5907A, 5908A and 5909A Flexible Test Leads for digital multimeter interfacing.
- Probe tip cap offers easy DIP lead testing and prevents accidental probe shorting.
- 4 mm banana plug probe tip mates into banana jacks for added test flexibility.

MATERIAL:

Probe Body: Polypropylene UL94 HB

Plug Tip: Body - Brass, N4mm Safety Jack: Brass, Nickel Plated

RATING:

IEC 1010-2-031, Category III, P2 Compliant

Operating Voltage: 1000V

Current: 10 Amperes Max.

ORDERING INFORMATION: Model 5906A (Includes a set of one black and one red probe)

Probe set is also included in many Pomona DMM Test Kits.

All dimensions are in inches. Tolerances (except noted): .xx = ±.02” (.51 mm), .xxx = ±.005” (.127 mm).

All specifications are to the latest revisions. Specifications are subject to change without notice.

Registered trademarks are the property of their respective companies. Made in USA